



ASSEMBLY GUIDE

WOODRIDGE™ WOOD PELLET GRILL



**SCAN FOR
STEP BY STEP
ANIMATED
INSTRUCTIONS**

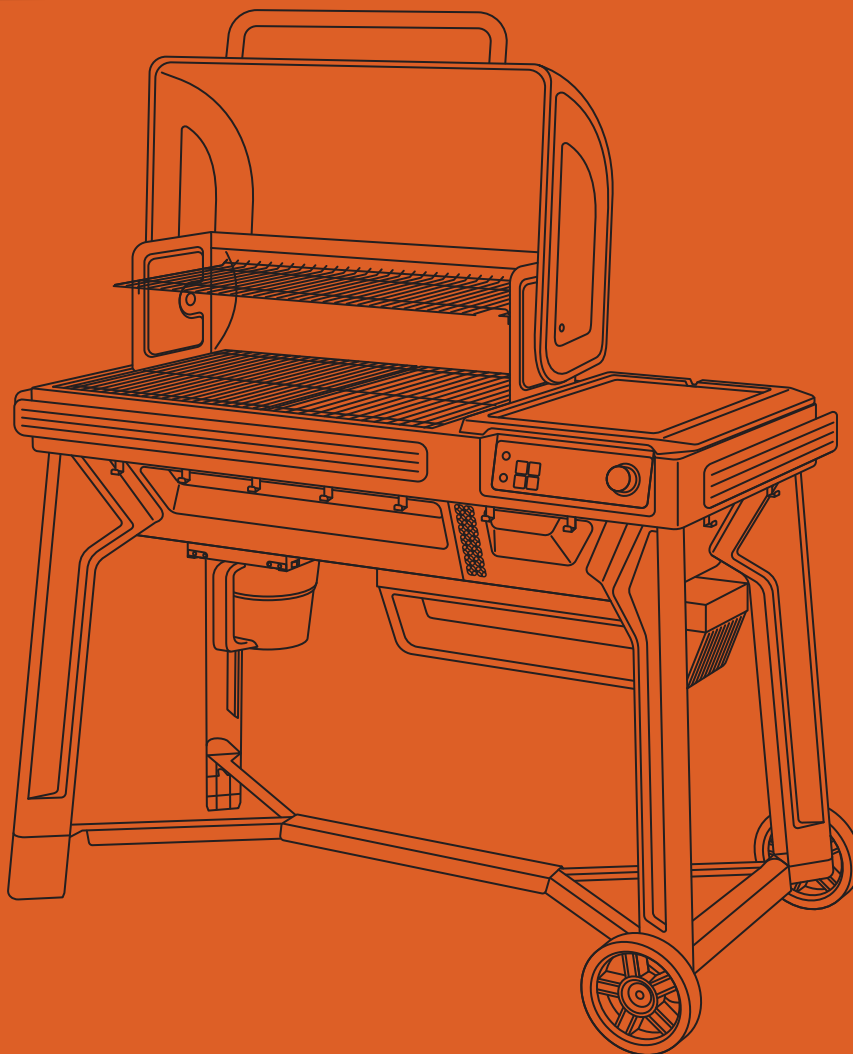

A MAJOR CAUSE OF FIRES IS FAILURE TO MAINTAIN REQUIRED CLEARANCES (AIR SPACES) TO COMBUSTIBLE MATERIALS. IT IS OF UTMOST IMPORTANCE THAT THIS PRODUCT BE INSTALLED ONLY IN ACCORDANCE WITH THESE INSTRUCTIONS.

IMPORTANT: RETAIN FOR FUTURE REFERENCE. READ CAREFULLY.

TFB86MLH
T17452
©2024 TRAERER PELLETT GRILLS LLC.
ALL RIGHTS RESERVED.

TRAERER PELLETT GRILLS LLC

533 South 400 West
Salt Lake City, UT 84101

TRAERER.COM

BEFORE YOU BUILD

PLEASE READ THIS ASSEMBLY GUIDE AND YOUR OWNER'S MANUAL BEFORE INSTALLATION AND USE OF YOUR TRAEGER® GRILL. FAILURE TO FOLLOW THE INSTRUCTIONS IN THIS ASSEMBLY GUIDE AND YOUR OWNER'S MANUAL COULD RESULT IN PROPERTY DAMAGE, BODILY INJURY, OR EVEN DEATH.

When using your grill, maintain a MINIMUM distance of 20 inches (50.8 cm) from the grill to any nearby combustibles, including wooden railings, home siding, window frames, furniture, trees, trash receptacles, etc. Do not install or operate this grill on combustible floors or surfaces, indoors, or under a combustible ceiling or overhang. Read the Owner's Manual for additional instructions and warnings.

SETUP SPACE



PRO TIP: Build on the bottom tray of the shipping box to help prevent scratches.

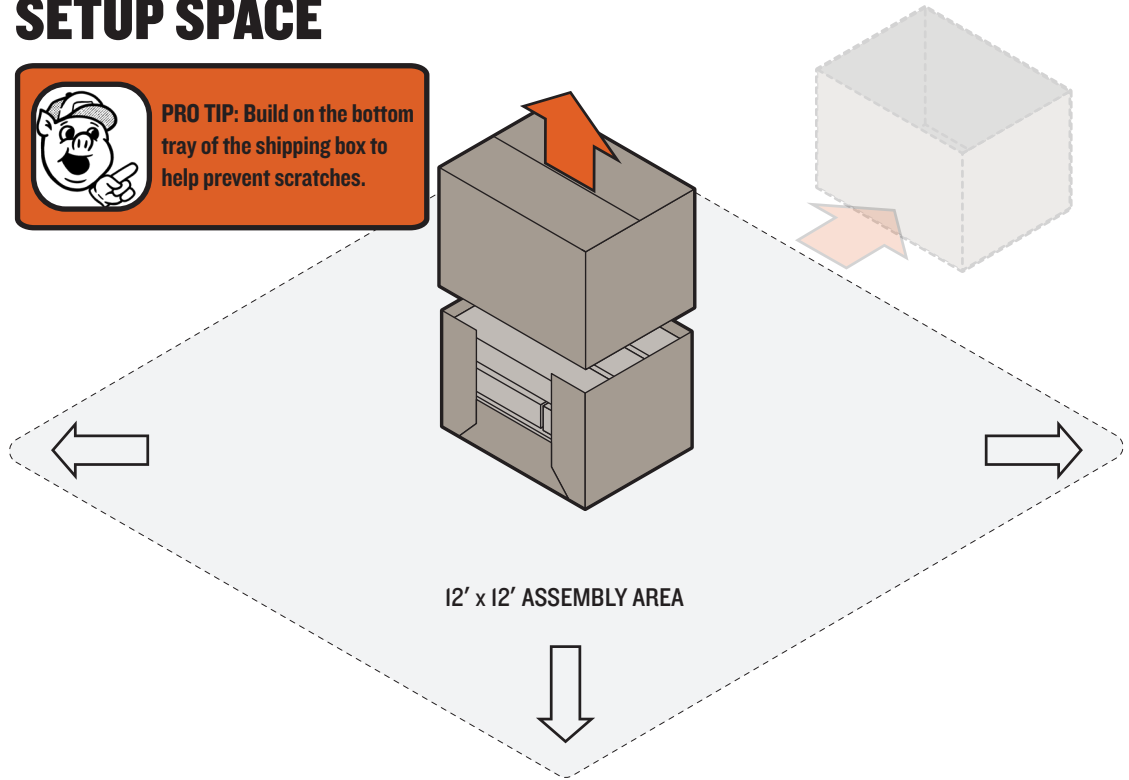

PRO TIP: We recommend assembling your grill with two people.

SETUP

Once all components are unpacked, arrange pieces onto the bottom tray of the shipping box.

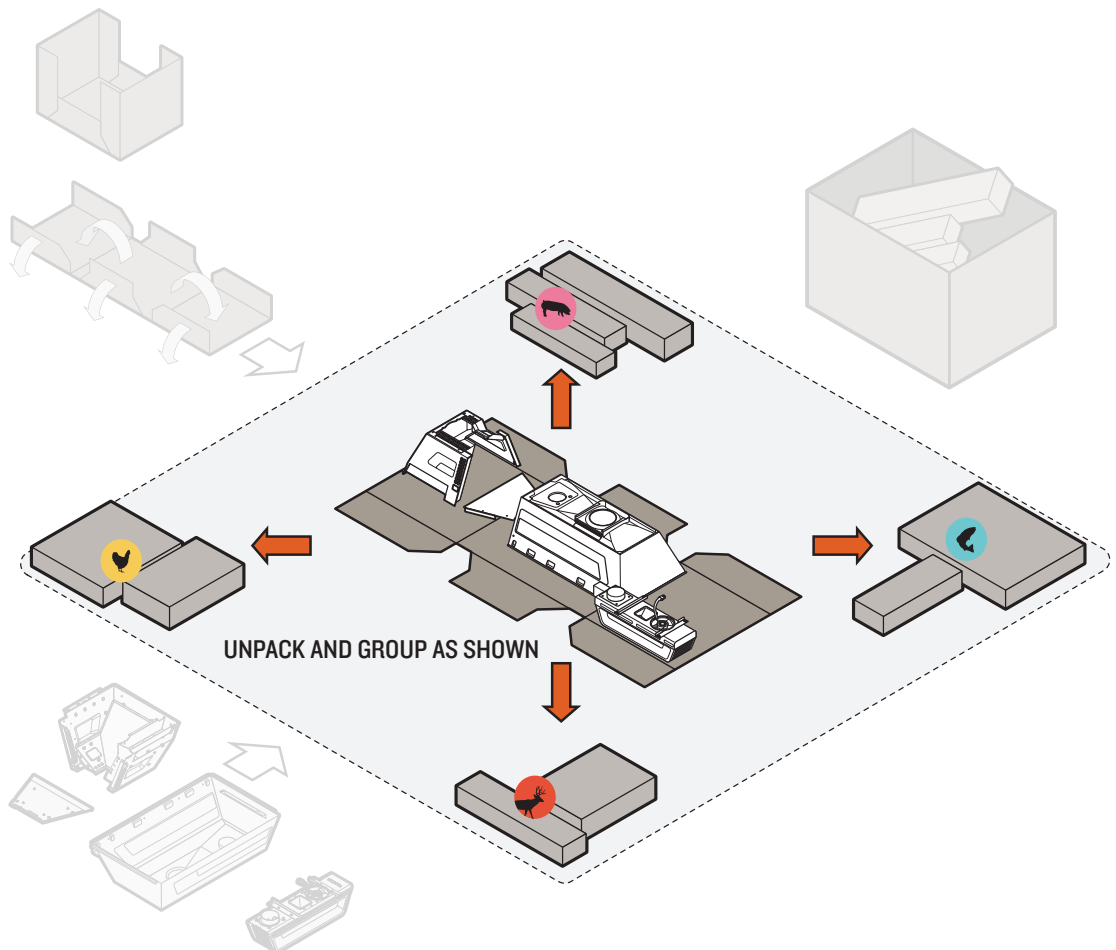

GROUP BOXES BY THEIR IDENTIFYING SYMBOLS, SHOWN BELOW:



COMPARTMENTS & LEGS



WHEELS & HOOVES



CONTROLS & SHELVING



LID & GRILL INTERNALS



HARDWARE (TOTAL QUANTITIES)

1:1 SCALE

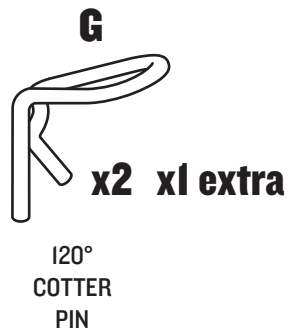
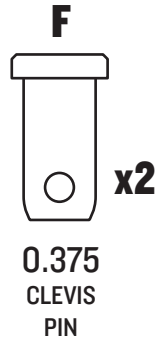
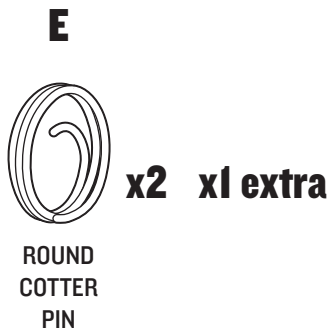
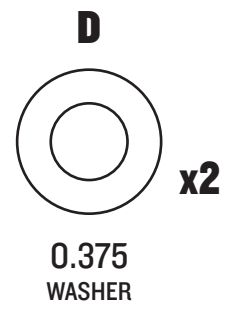
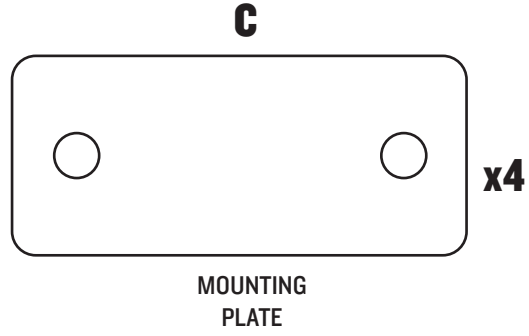
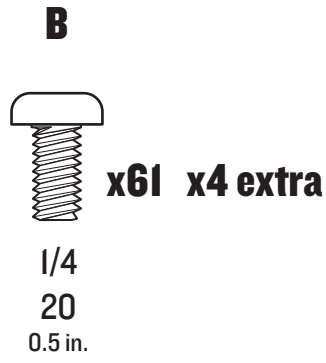
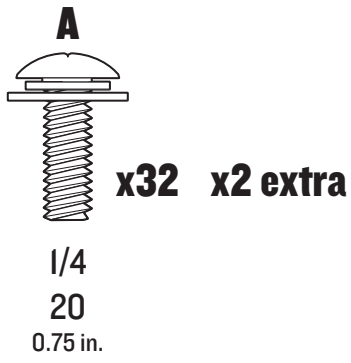



CHAPTERS

CHAPTER 1 – PAGE 5
COMPARTMENTS & LEGS

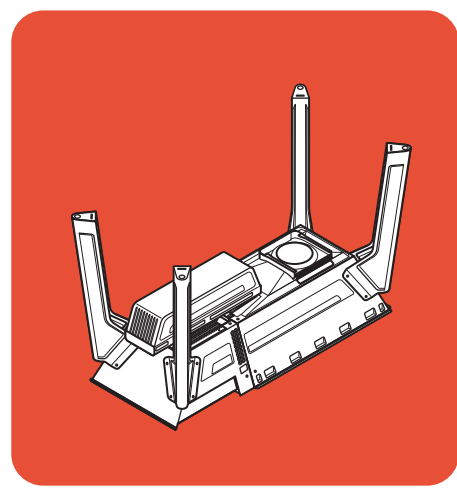

CHAPTER 2 – PAGE 13
WHEELS & HOOVES

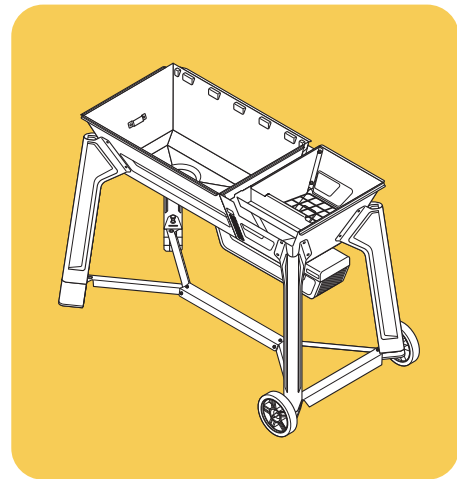
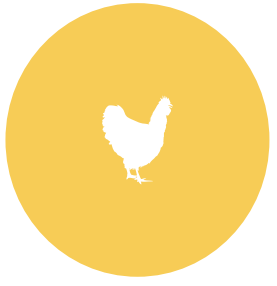

CHAPTER 3 – PAGE 19
CONTROLS & SHELVING

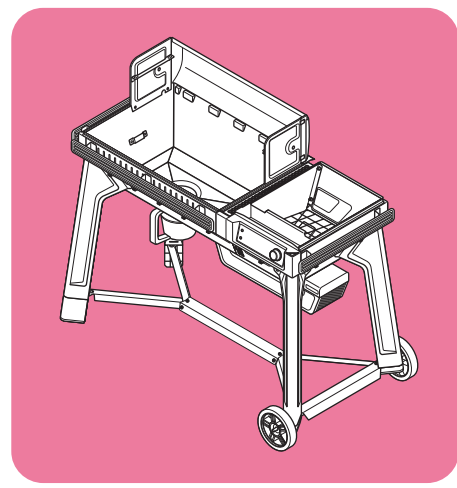

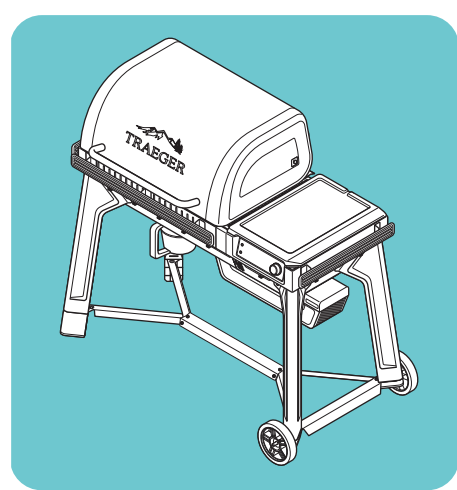

CHAPTER 4 – PAGE 31
LID & GRILL INTERNALS

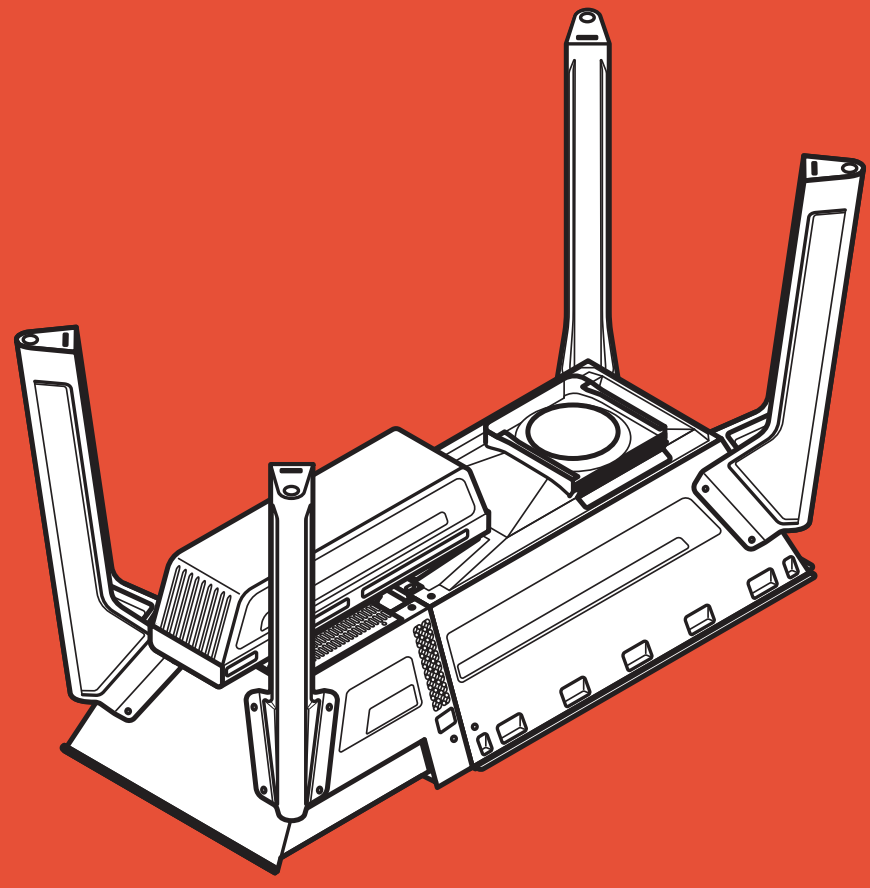

CHAPTER 1

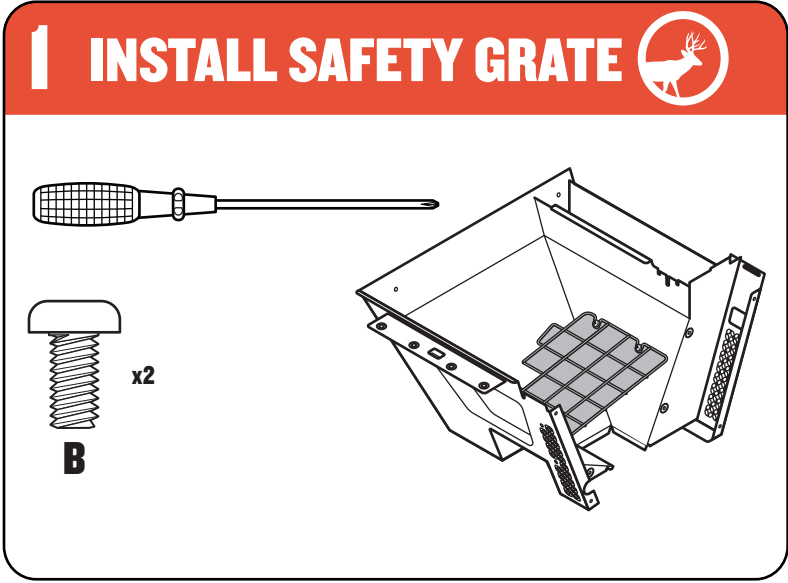
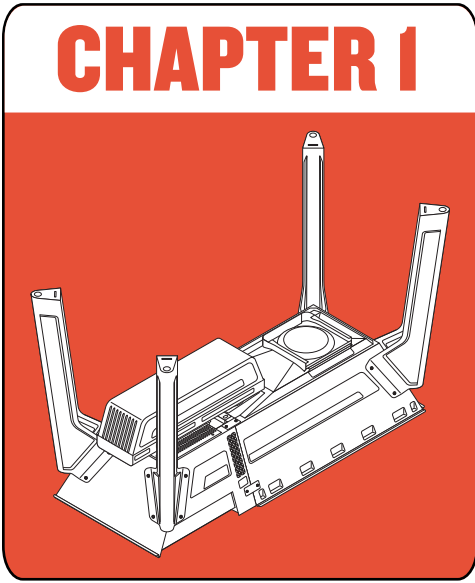

COMPARTMENTS & LEGS



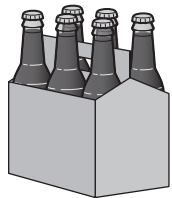
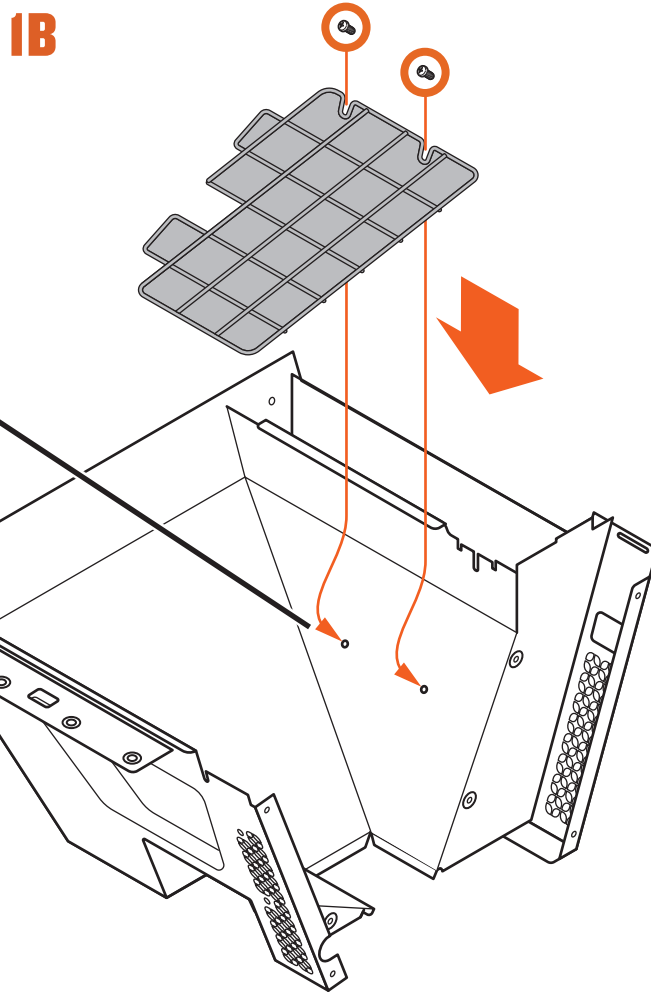
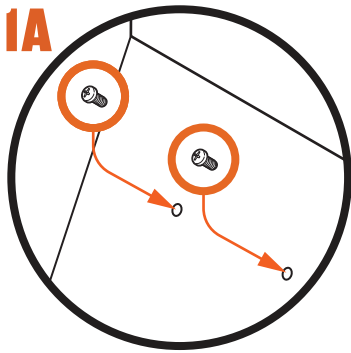

PRO TIP: Hand-tighten all screws first, then finish tightening with screwdriver.



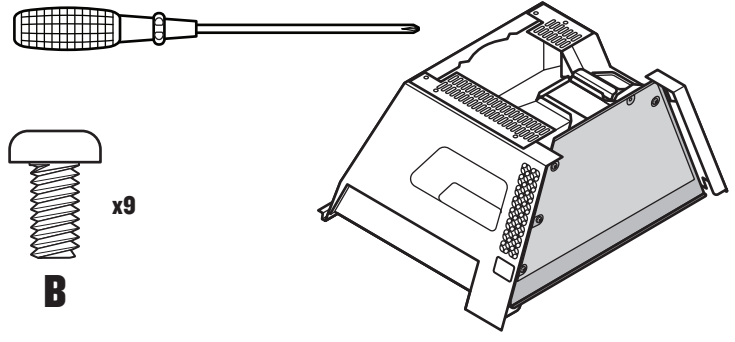

2 ASSEMBLE HOPPER



2A

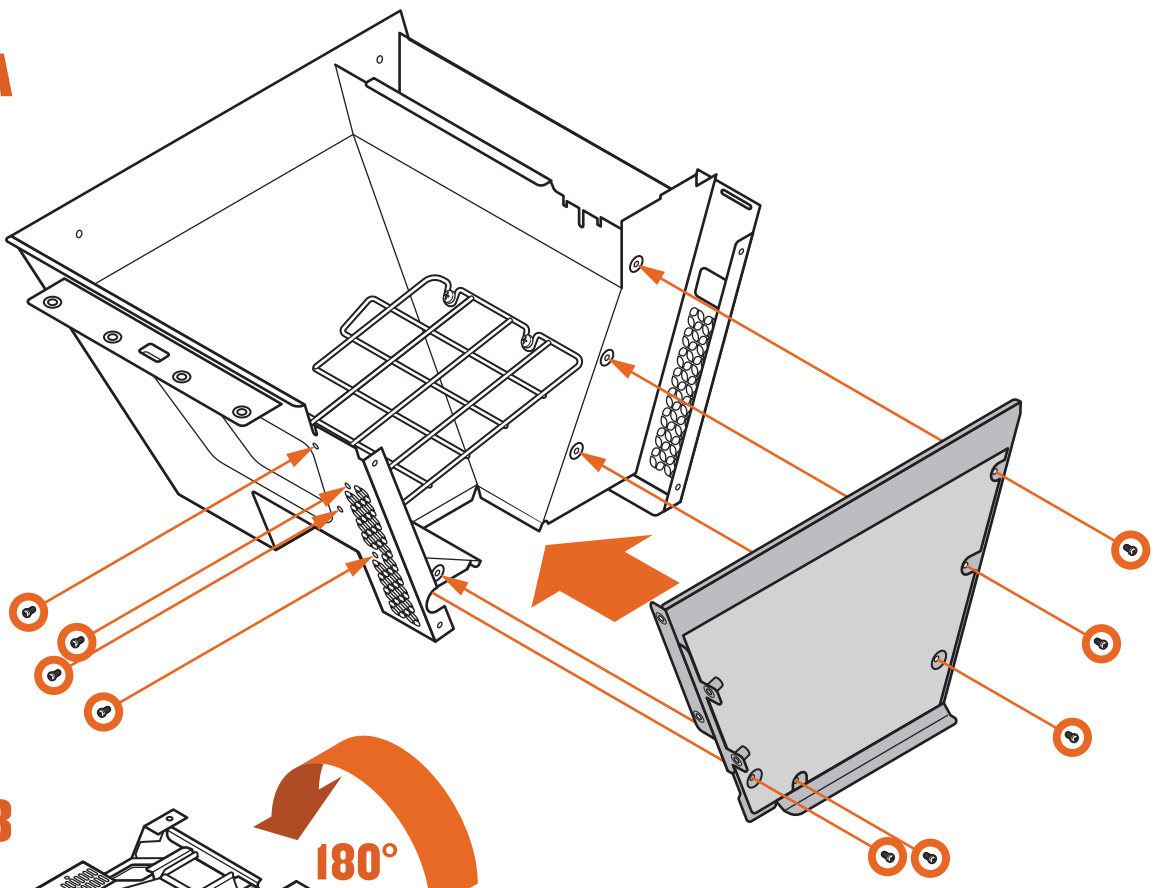

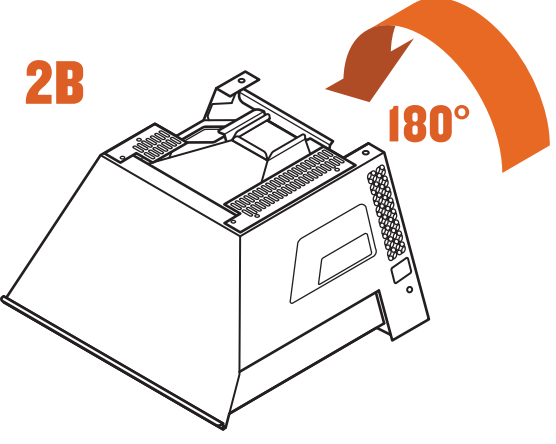

2B



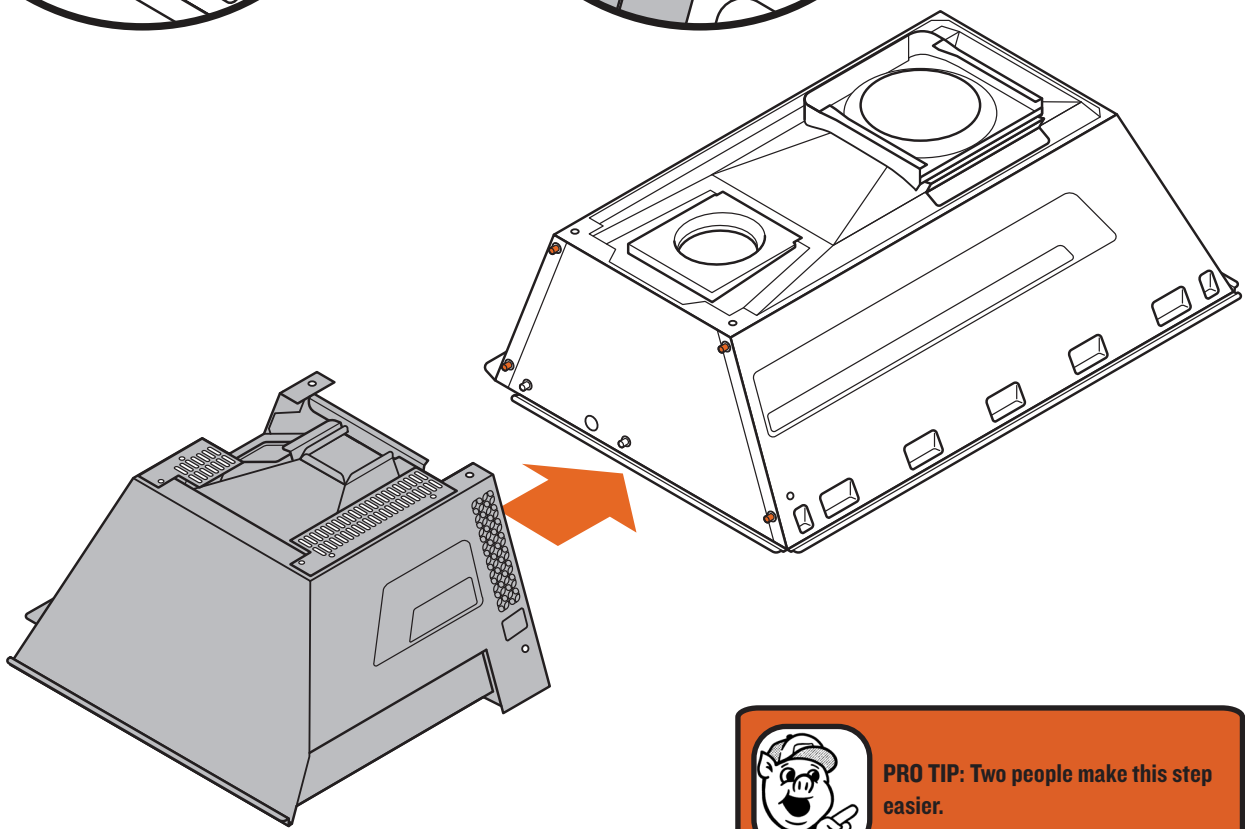
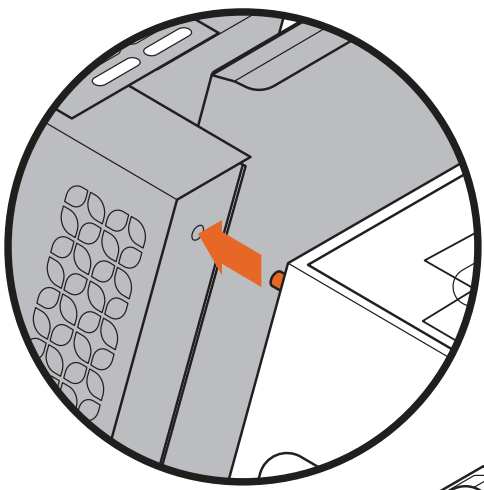
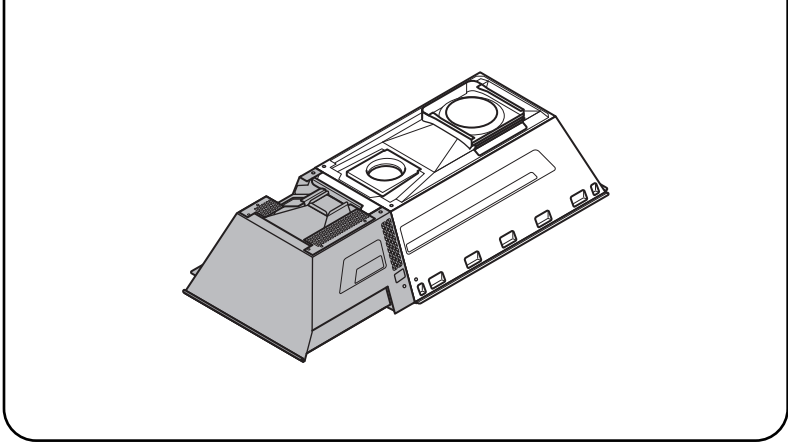

3A ATTACH HOPPER TO BODY



 **PRO TIP:** Two people make this step easier.



3B ATTACH HOPPER TO BODY

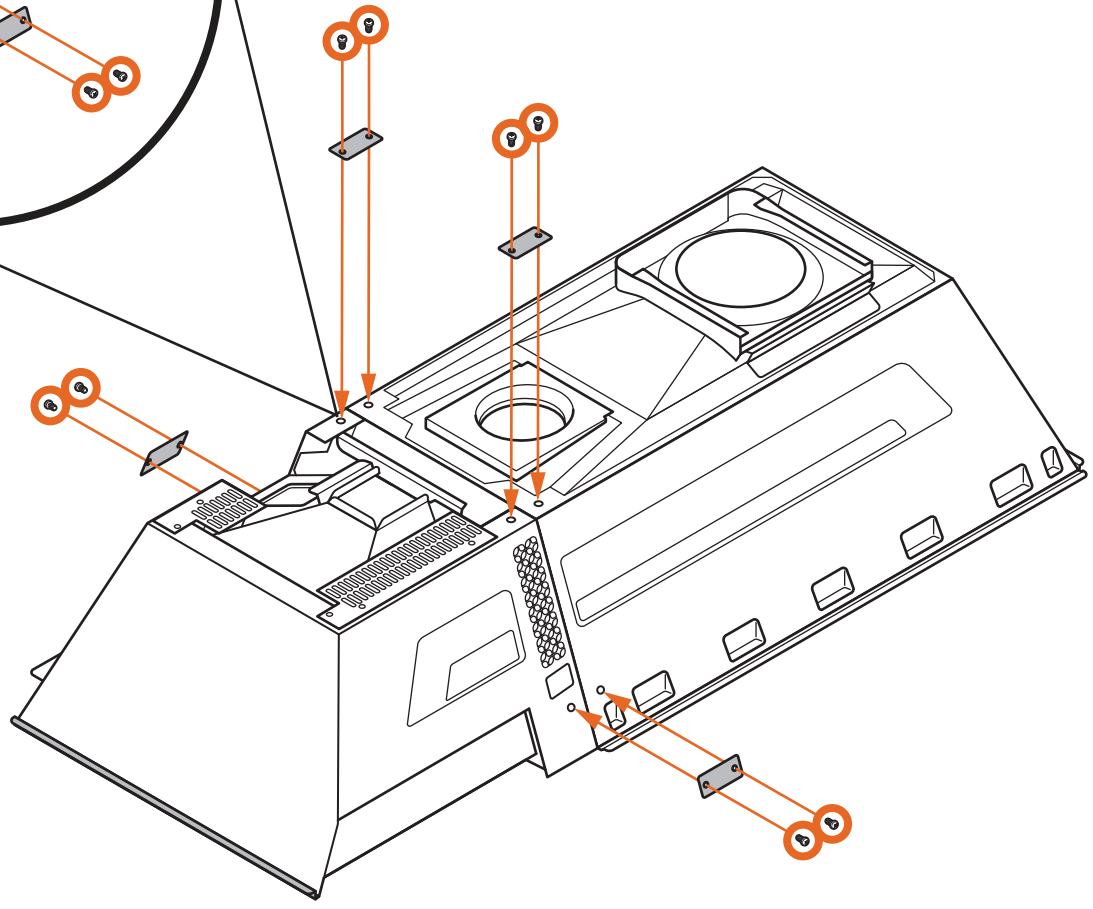
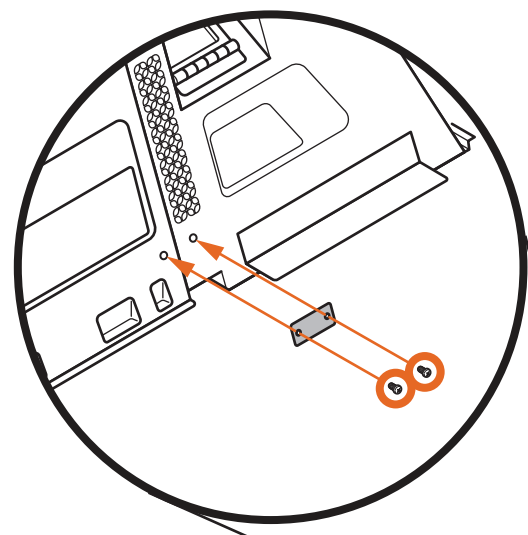
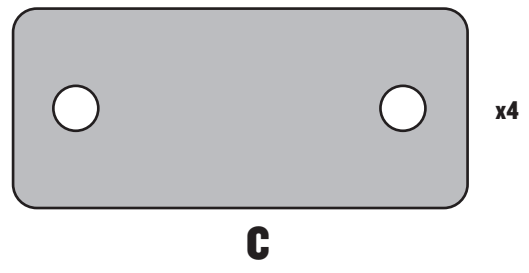
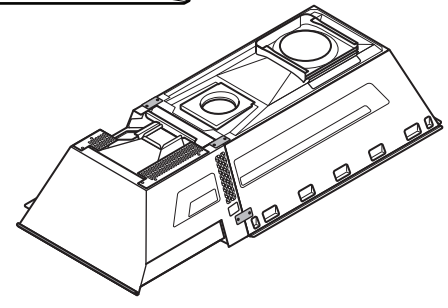
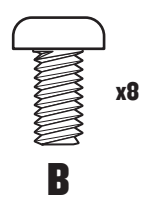
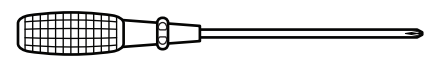



4 CONNECT AUGER BOX

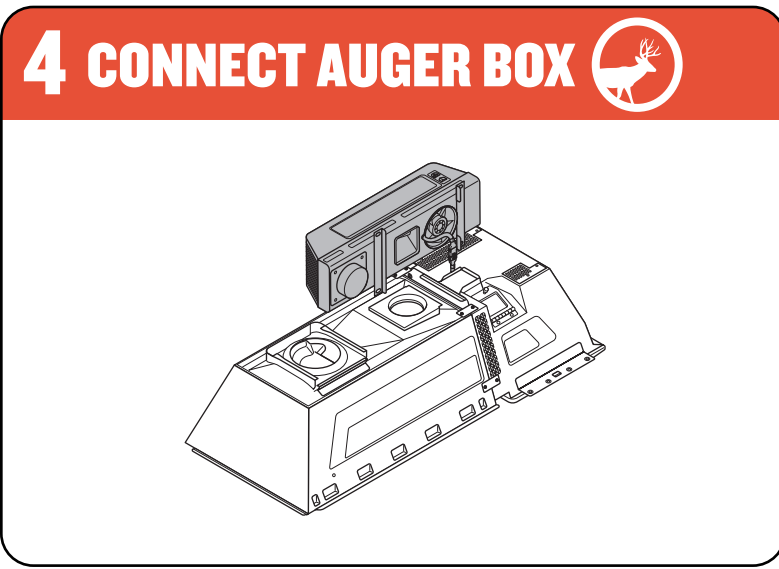
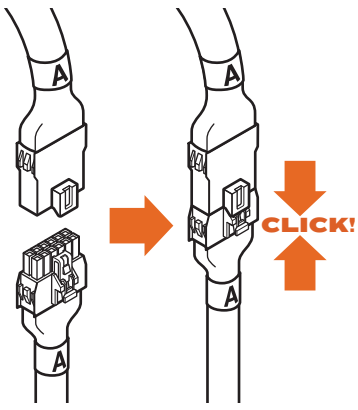
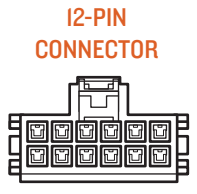

PRO TIP: Have a second person hold the auger box while you connect the cord.



PRO TIP: Don't forget to remove the twist tie holding down the cord.

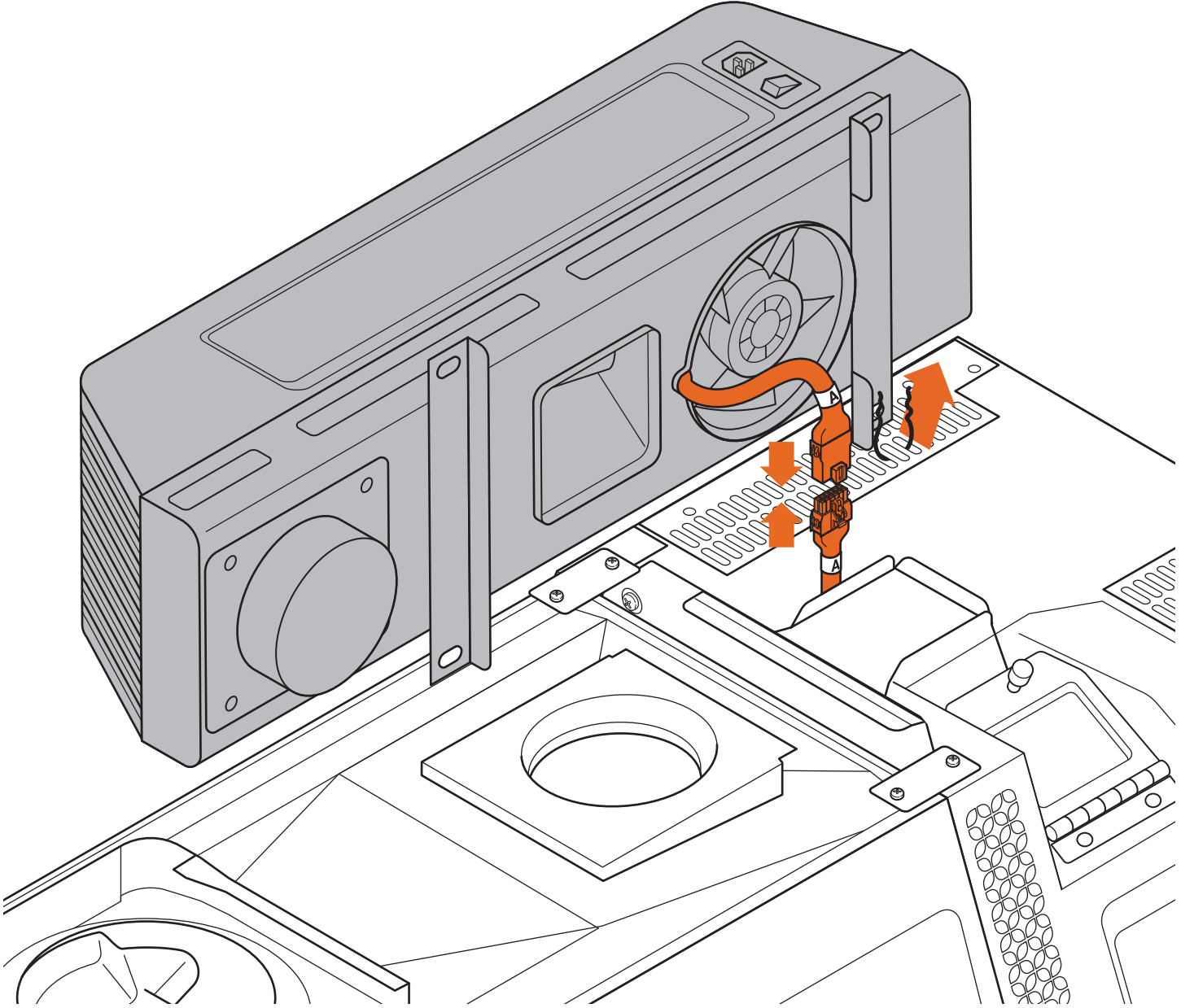



5 ATTACH AUGER BOX

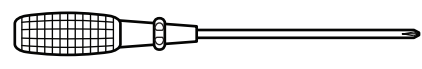

Use **THIS** screw now!

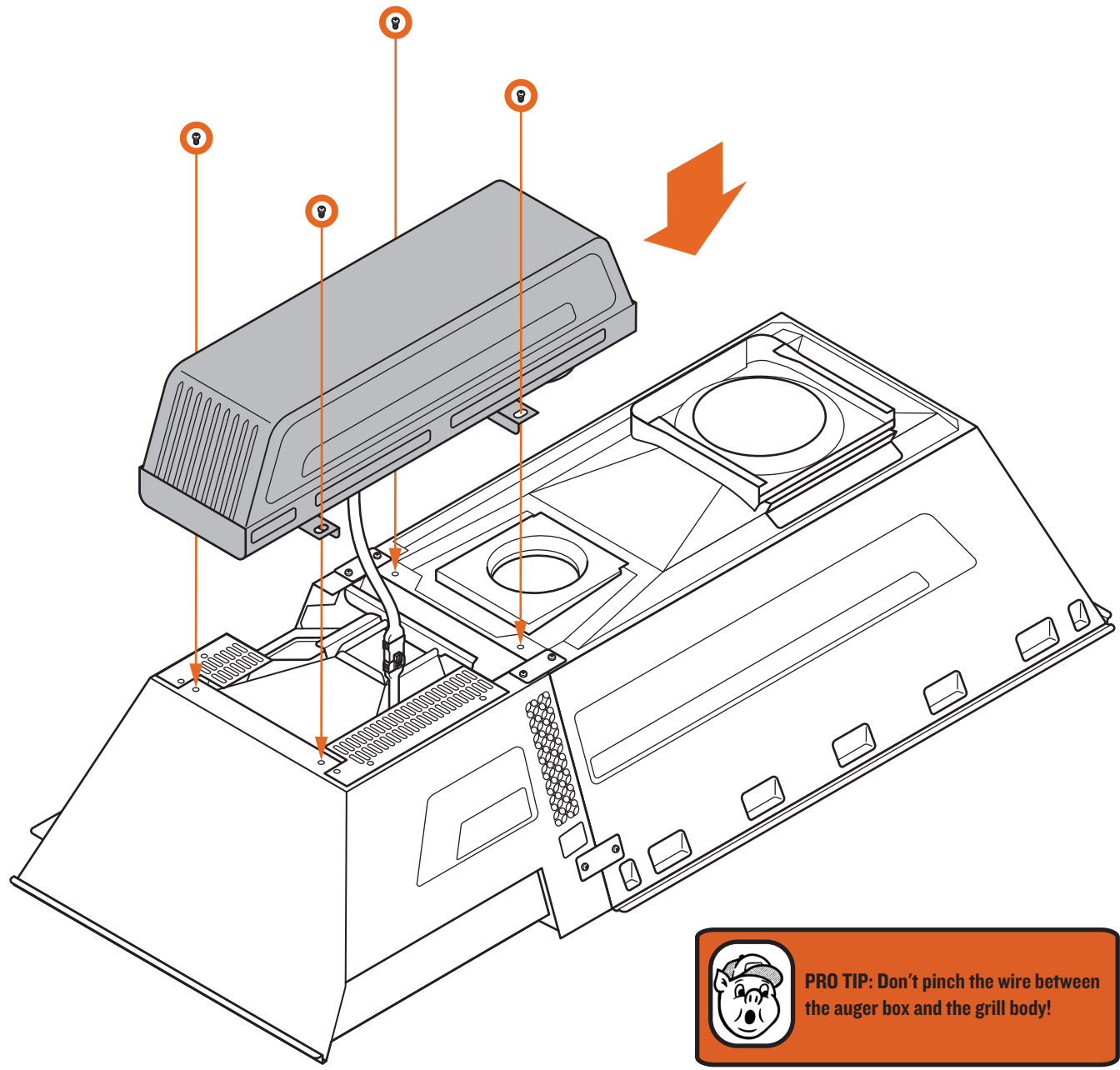
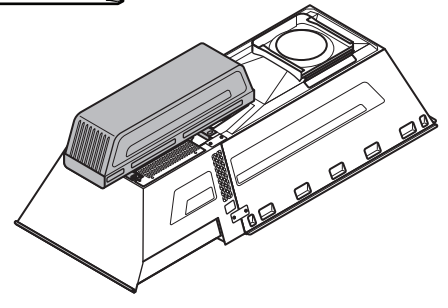
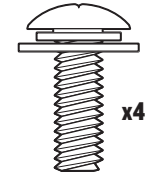

 **PRO TIP:** Don't pinch the wire between the auger box and the grill body!





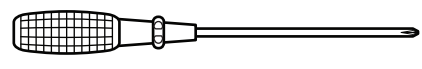

6 ATTACH LEGS

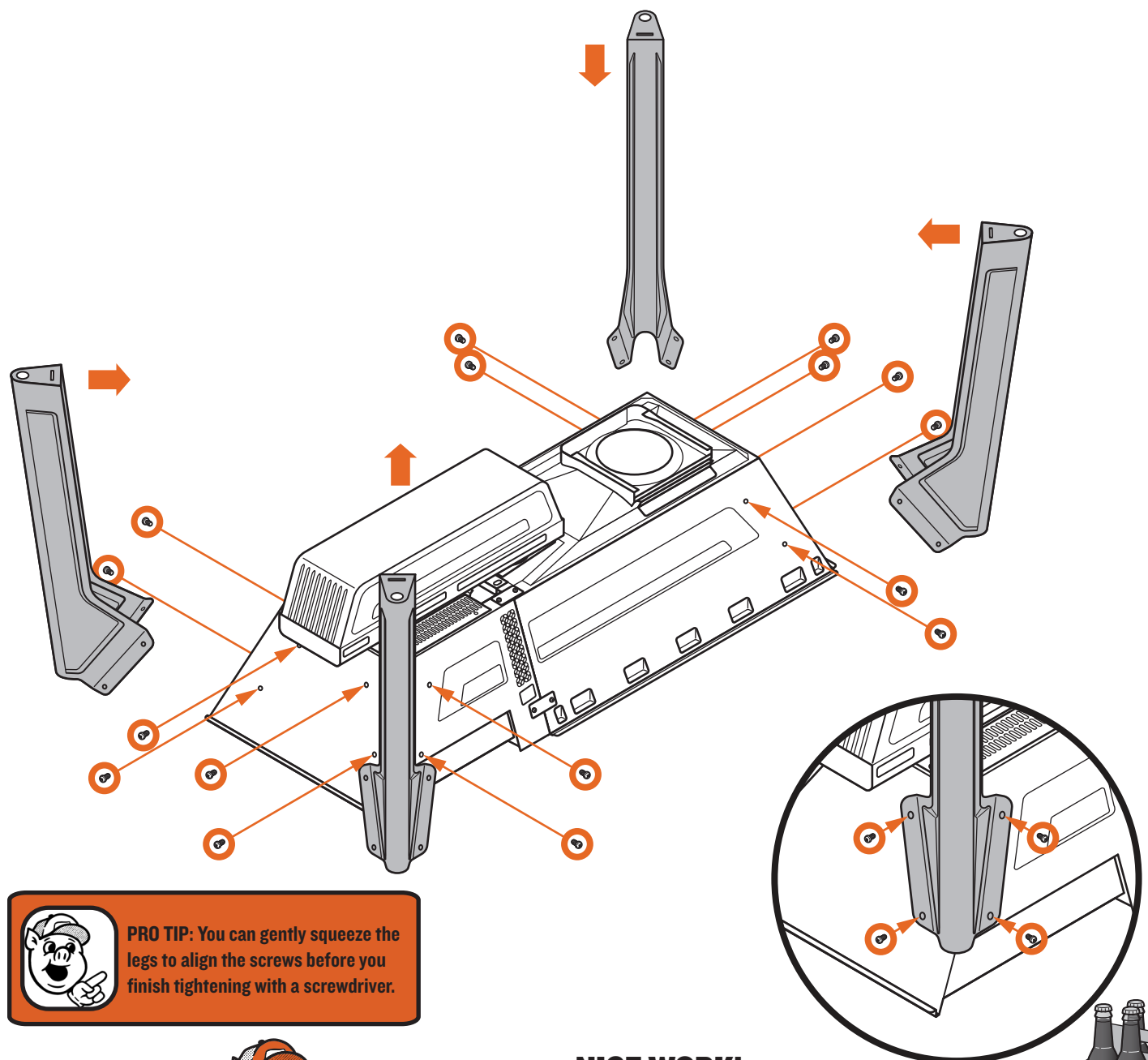
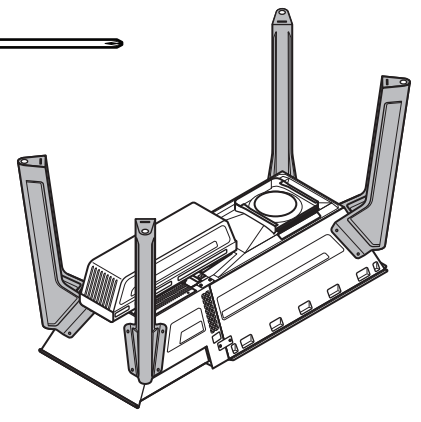
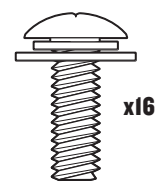

Use **THIS** screw again!



 **PRO TIP:** You can gently squeeze the legs to align the screws before you finish tightening with a screwdriver.

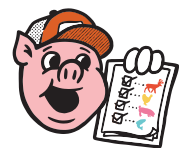

**NICE WORK!
CHAPTER I COMPLETE!**

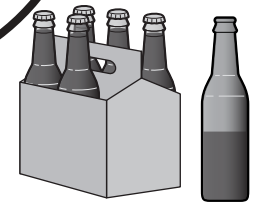

CHAPTER 2

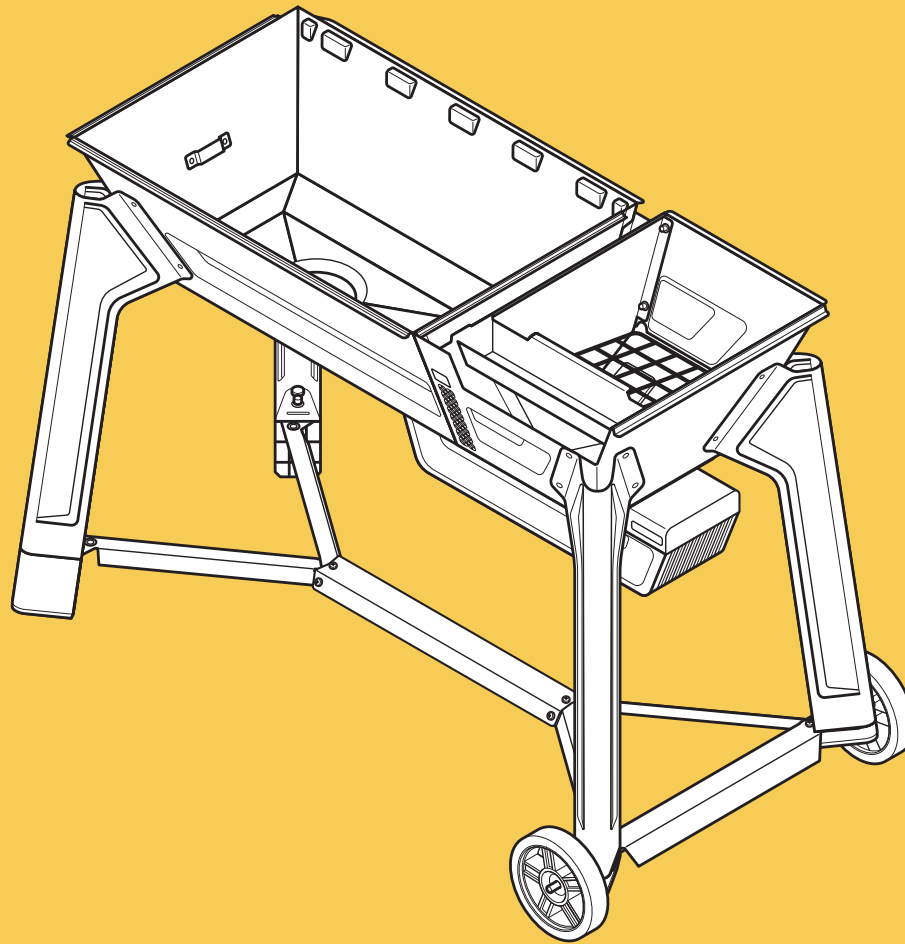

WHEELS & HOOVES

CHAPTER 2

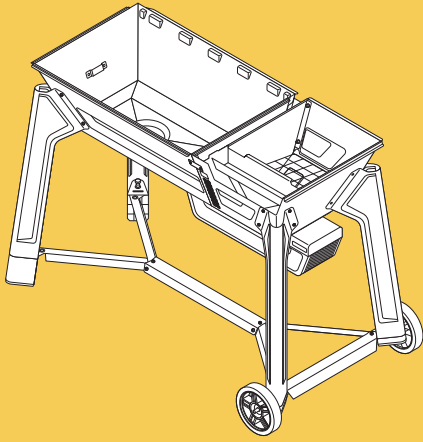

1 ASSEMBLE BRACE/AXLE COVER

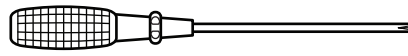

Use THIS screw again!

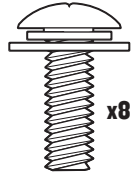

A

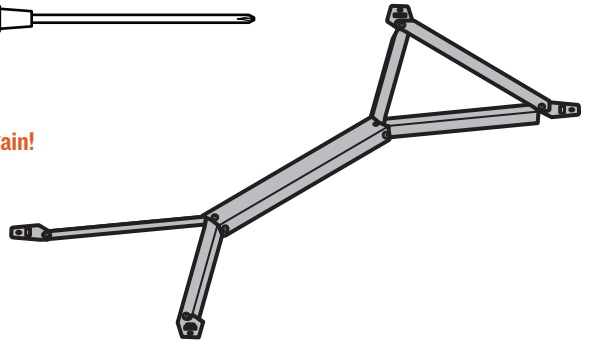

PRO TIP: Hand-tighten all screws first, then finish tightening with screwdriver.

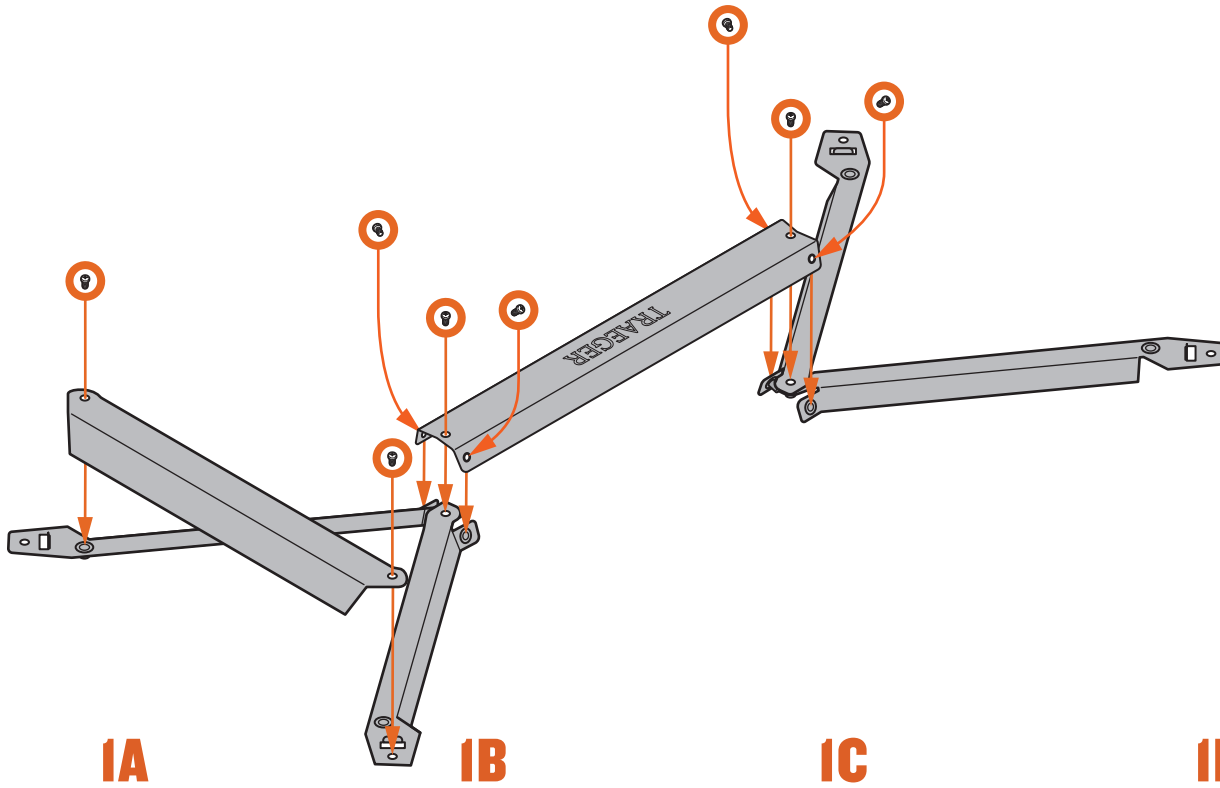

IA

IB

IC

ID

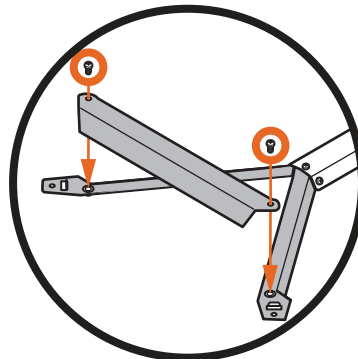
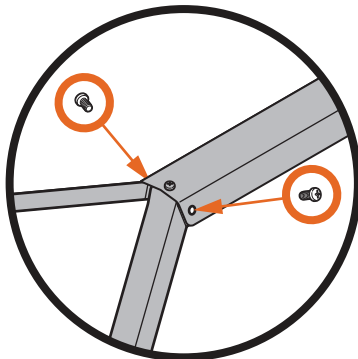
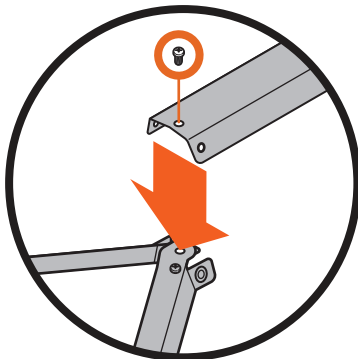
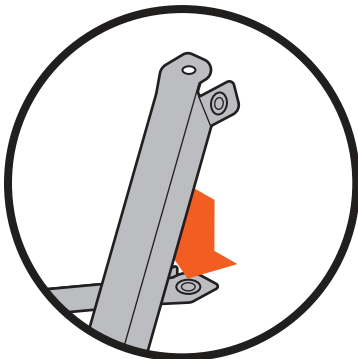

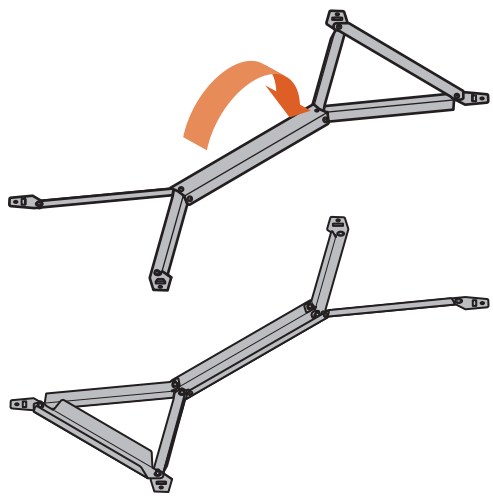

2 ATTACH BRACE/AXLE COVER

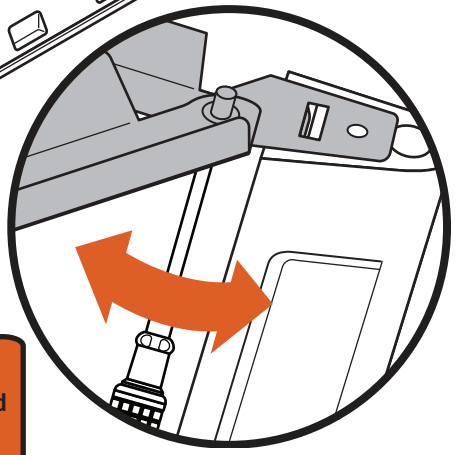
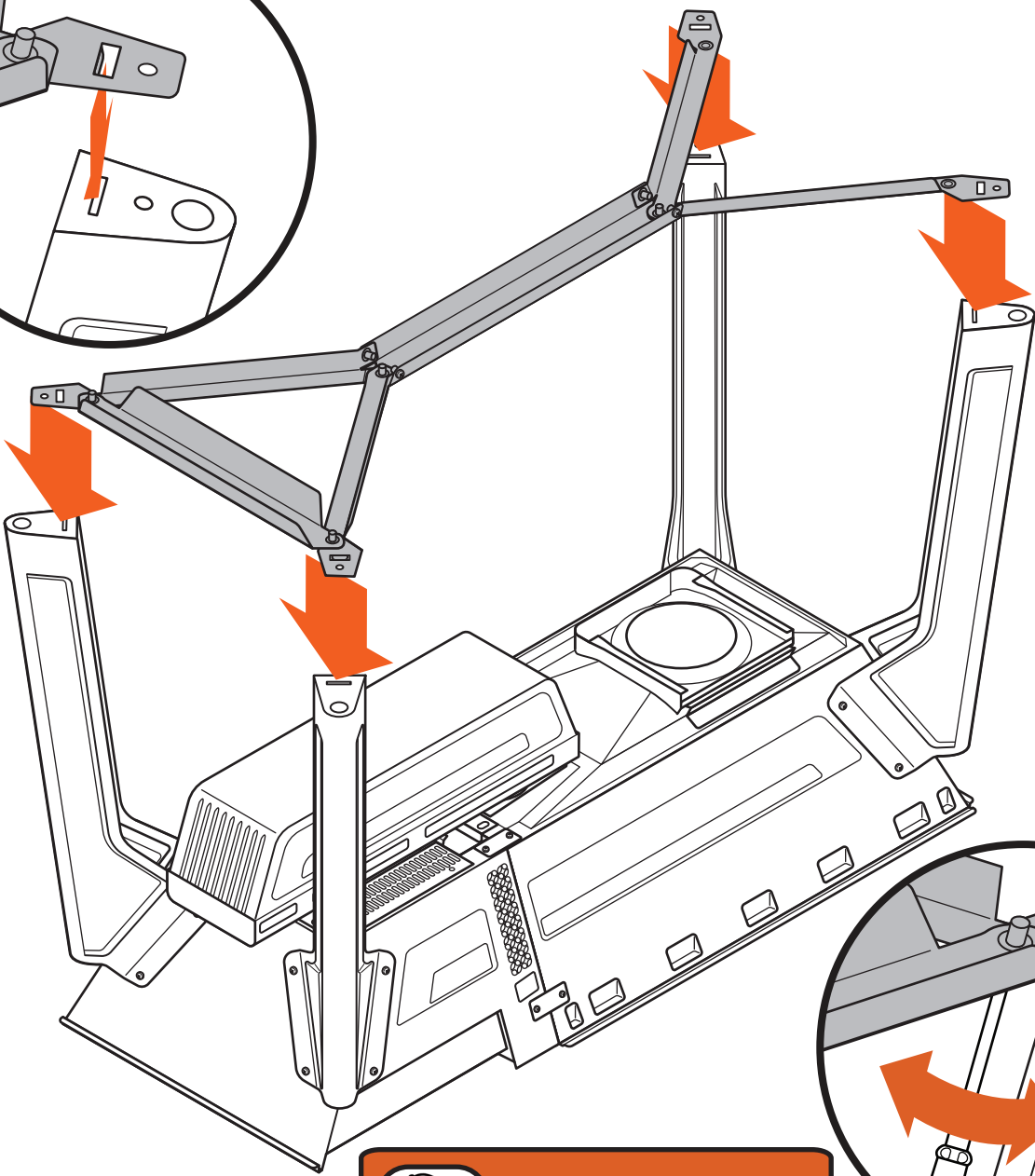
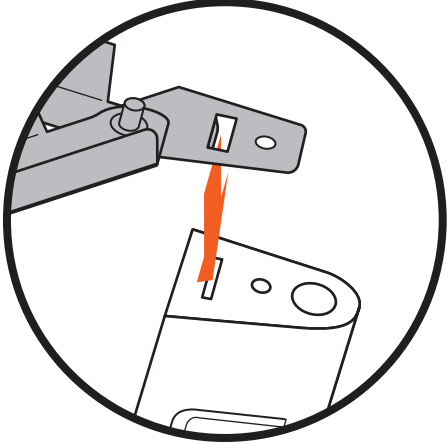
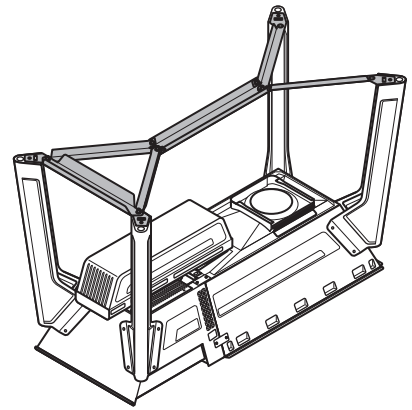

PRO TIP: To adjust brace, loosen and tighten screws as needed.

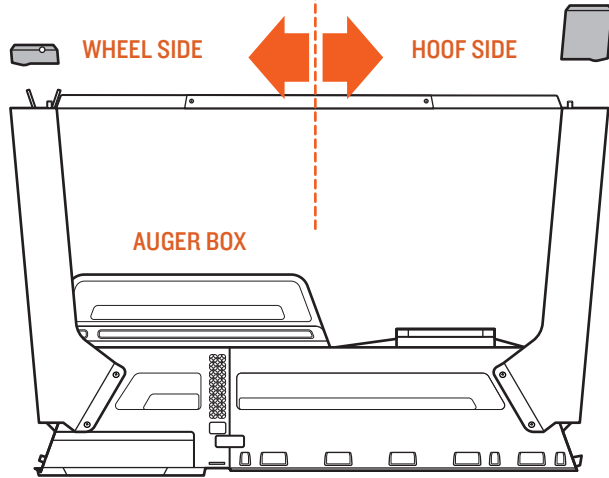

3 ATTACH WHEEL HOOVES

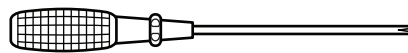

Use THIS screw again!

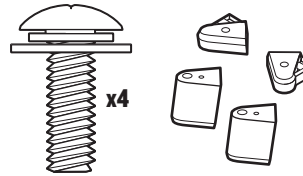

A

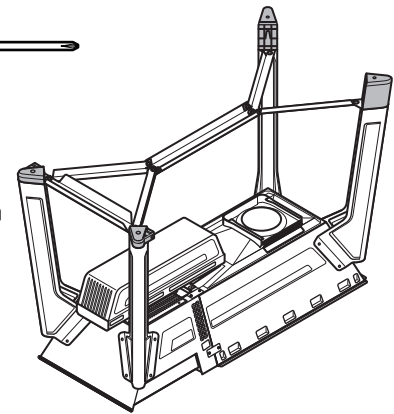

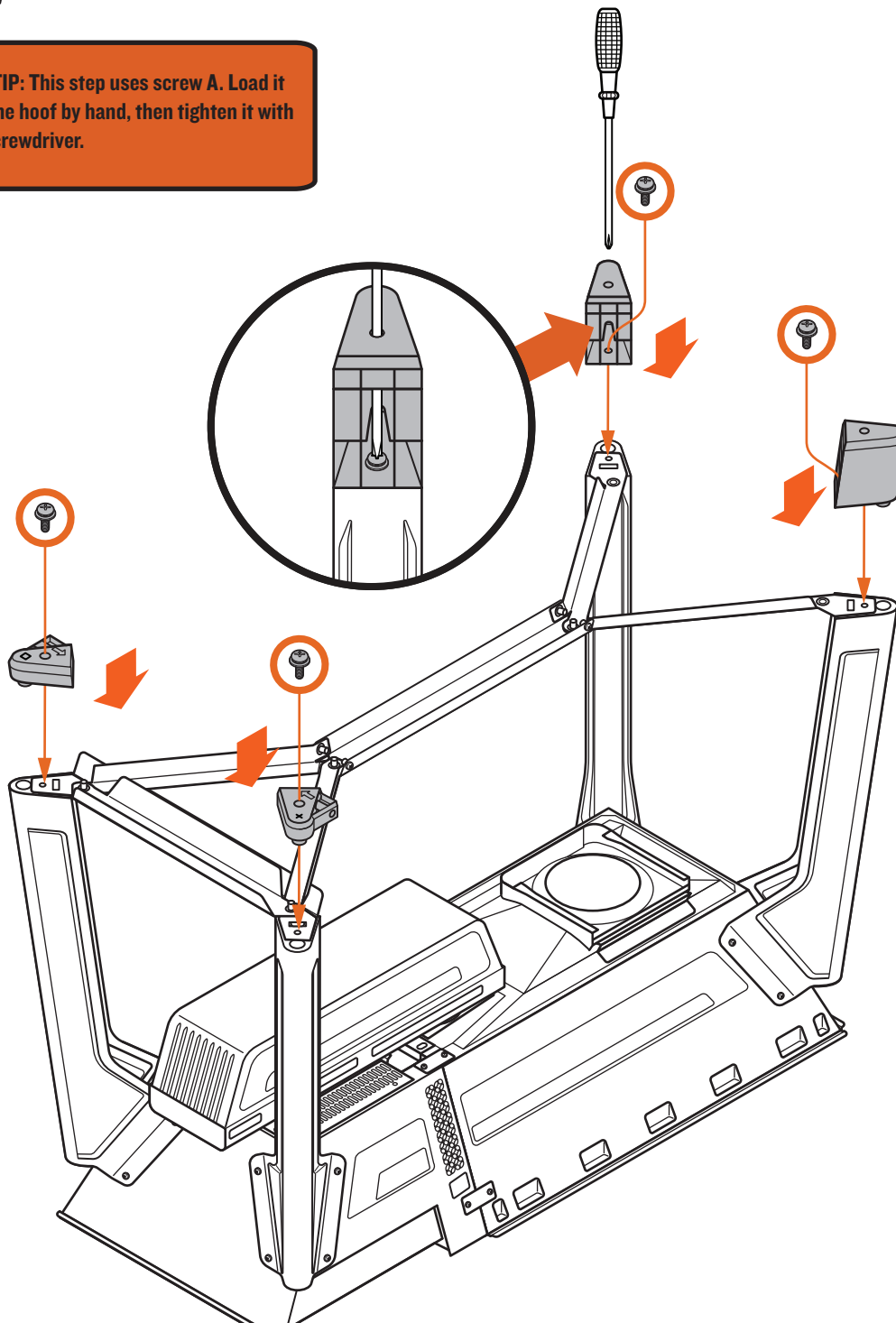

PRO TIP: This step uses screw A. Load it into the hoof by hand, then tighten it with the screwdriver.



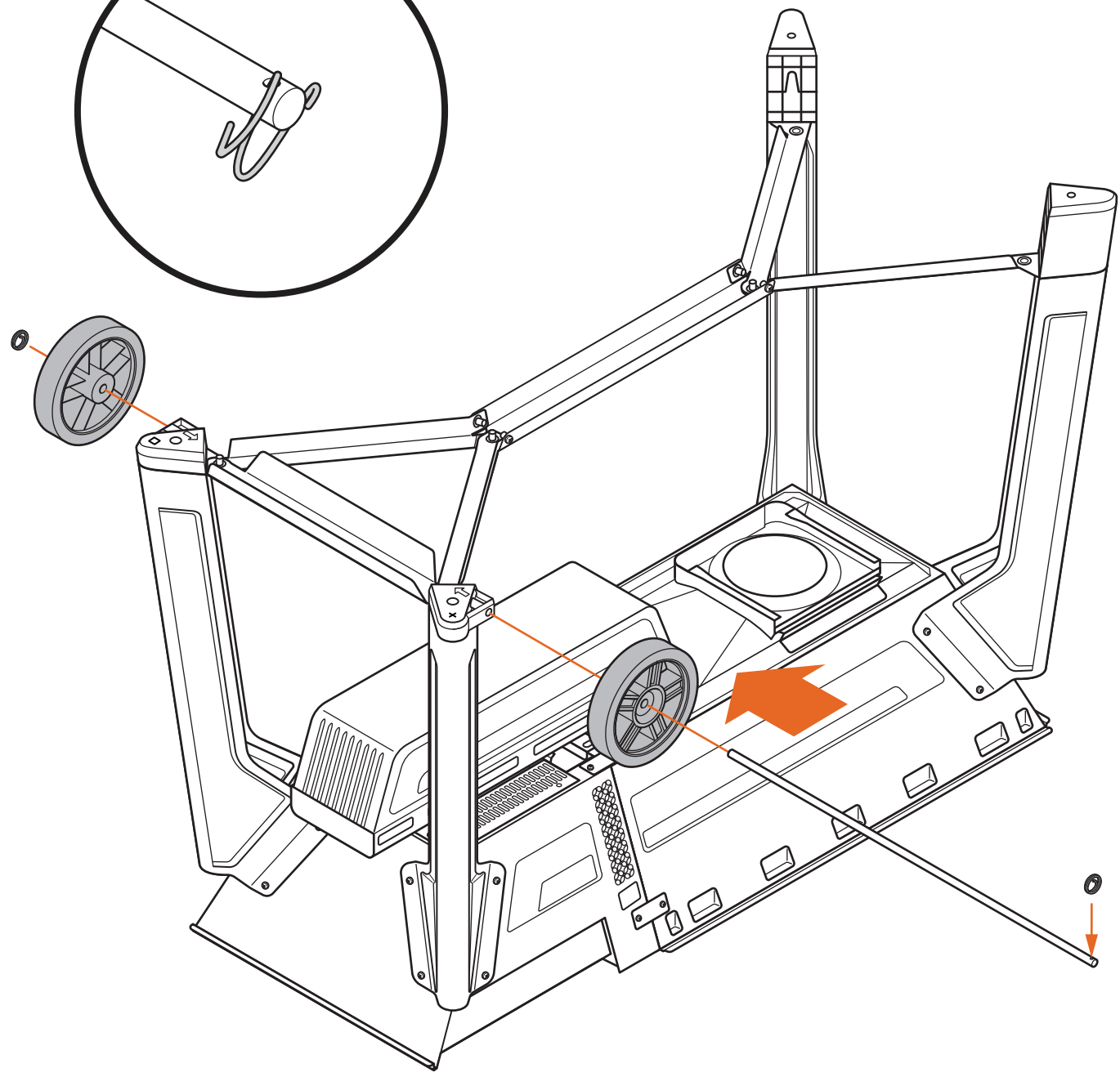
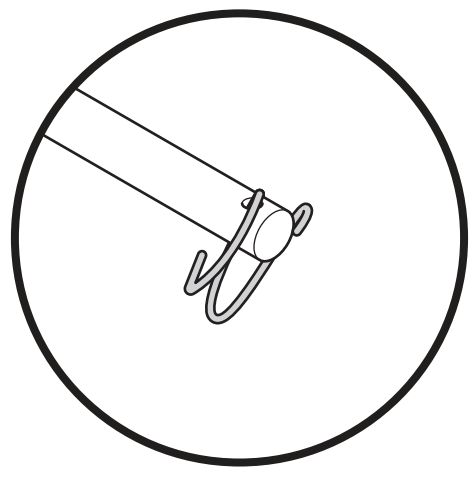
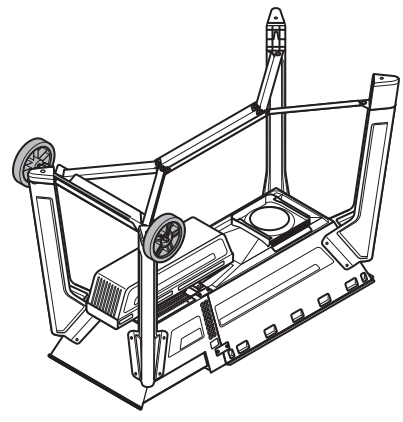
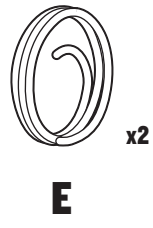

4 ASSEMBLE WHEELS





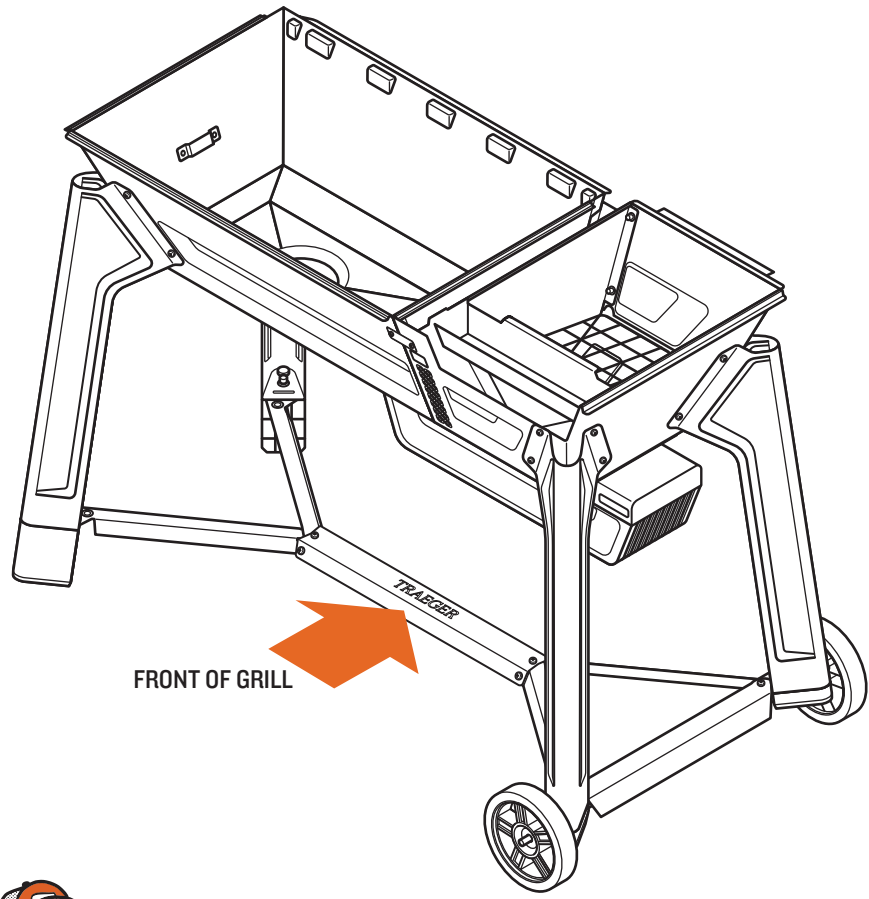
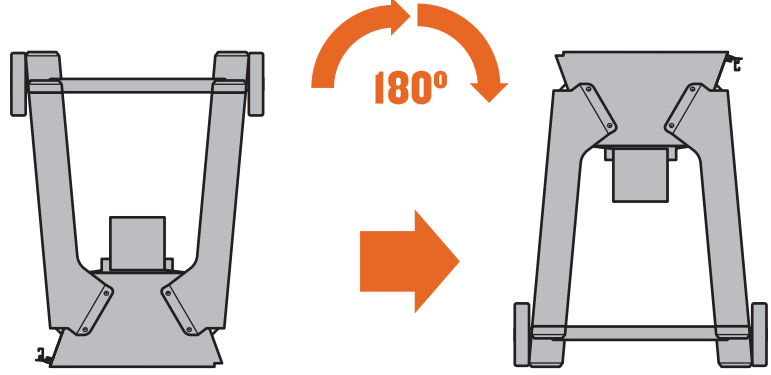
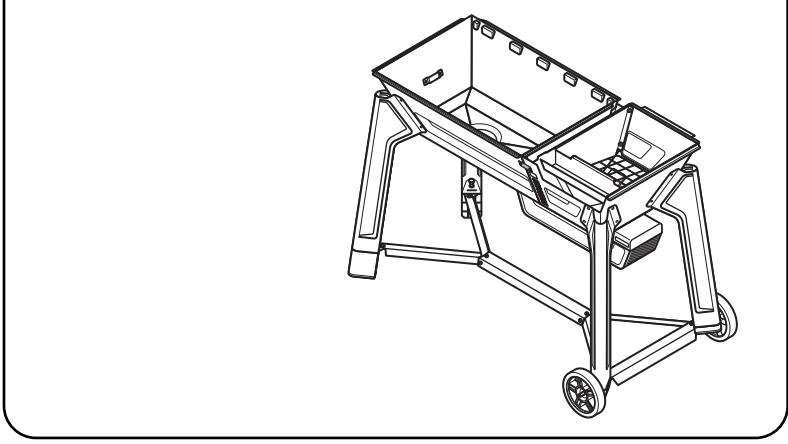

PRO TIP: Have a second person help lift and rotate the grill.

5 FLIP GRILL OVER

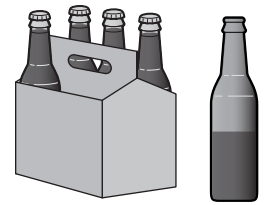

**NICE WORK!
CHAPTER 2 COMPLETE!**



CHAPTER 3

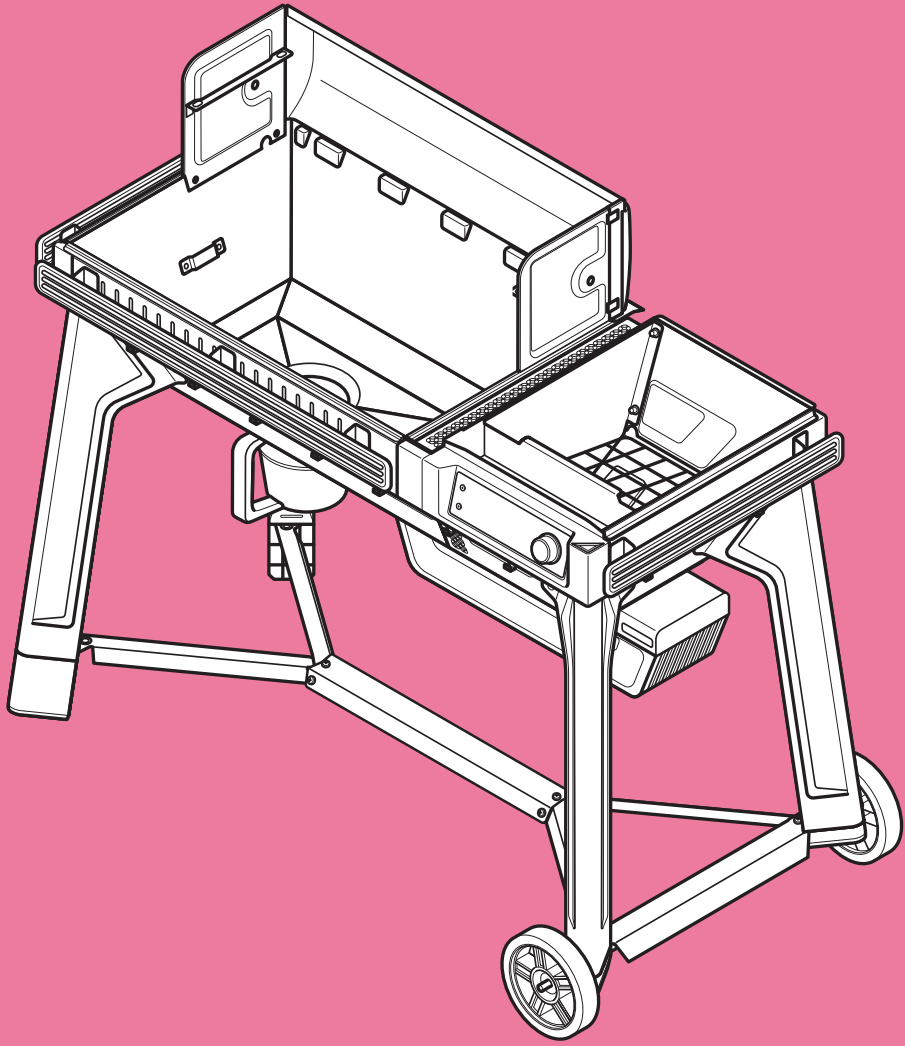

CONTROLS & SHELVING



CHAPTER 3

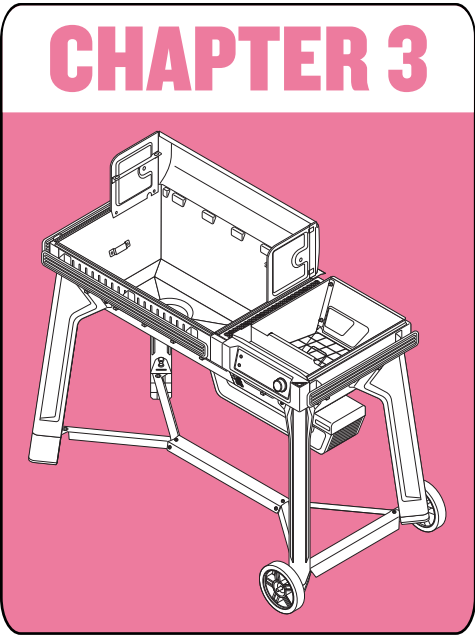

1 BUILD P.A.L. RAILS

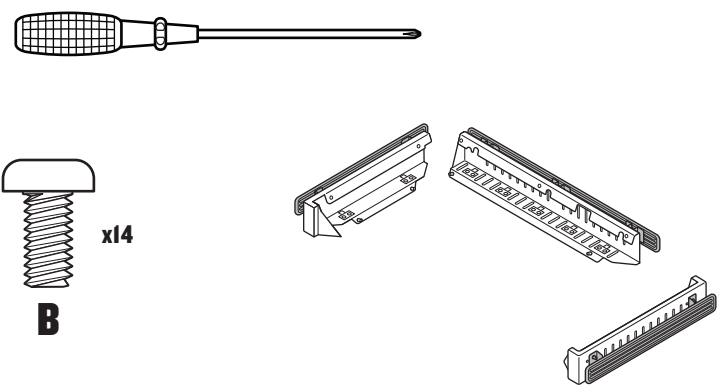

PRO TIP: Hand-tighten all screws first, then finish tightening with screwdriver.

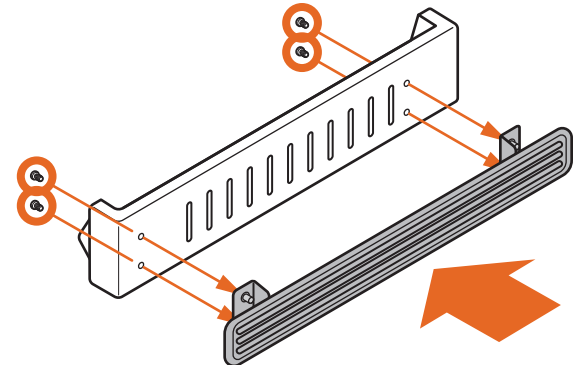
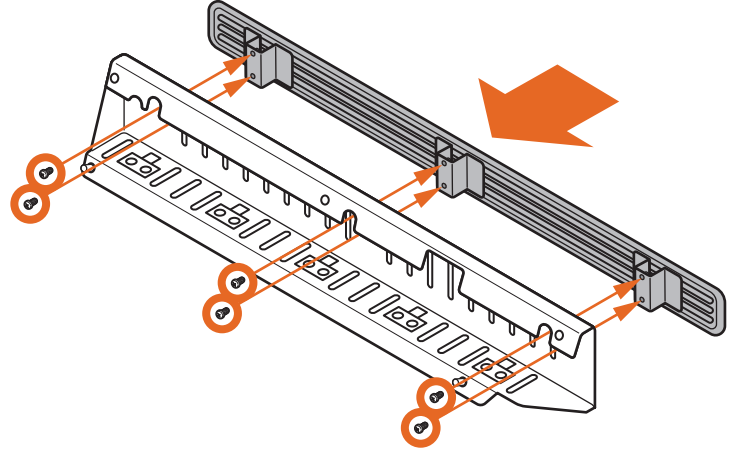
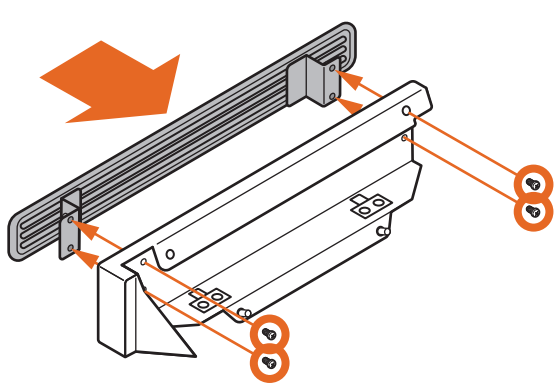



PRO TIP: This step can be tricky. Scan our QR code to access video animations for assembly. Jump to Chapter 3, Step 2 for a video.



PRO TIP: To prevent hardware from falling into the auger box, lay this manual on top of the grate.



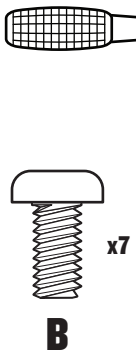
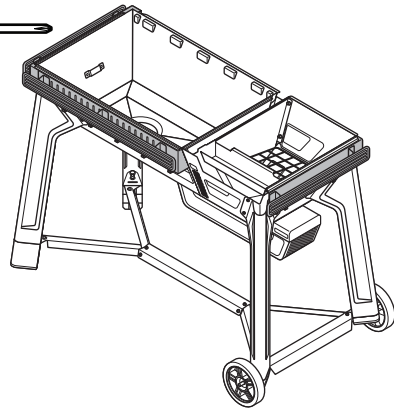
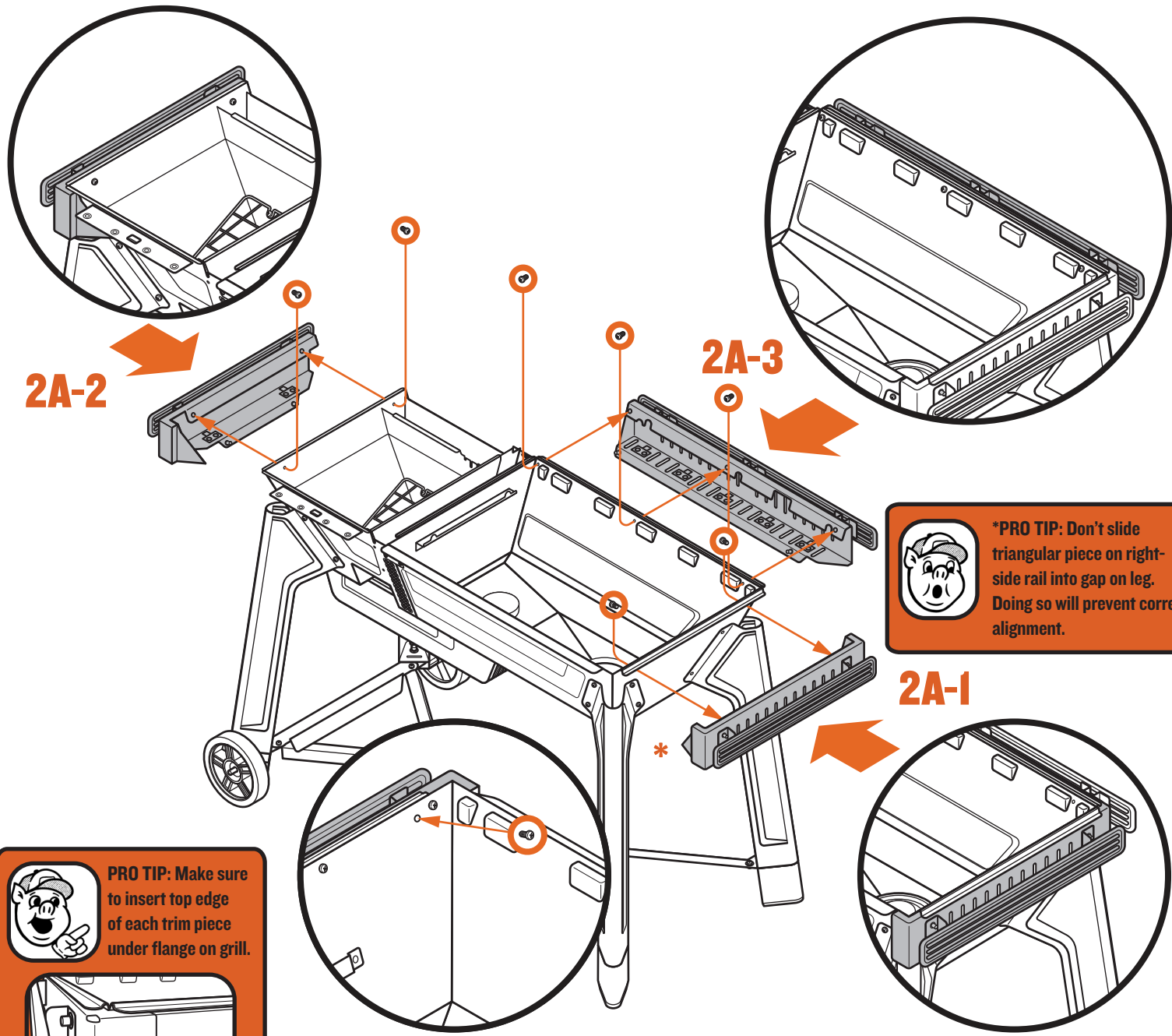

2A ATTACH P.A.L. TRIM

***PRO TIP:** Don't slide triangular piece on right-side rail into gap on leg. Doing so will prevent correct alignment.



PRO TIP: Make sure to insert top edge of each trim piece under flange on grill.

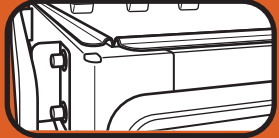

2B SECURE P.A.L. TRIM

B x6



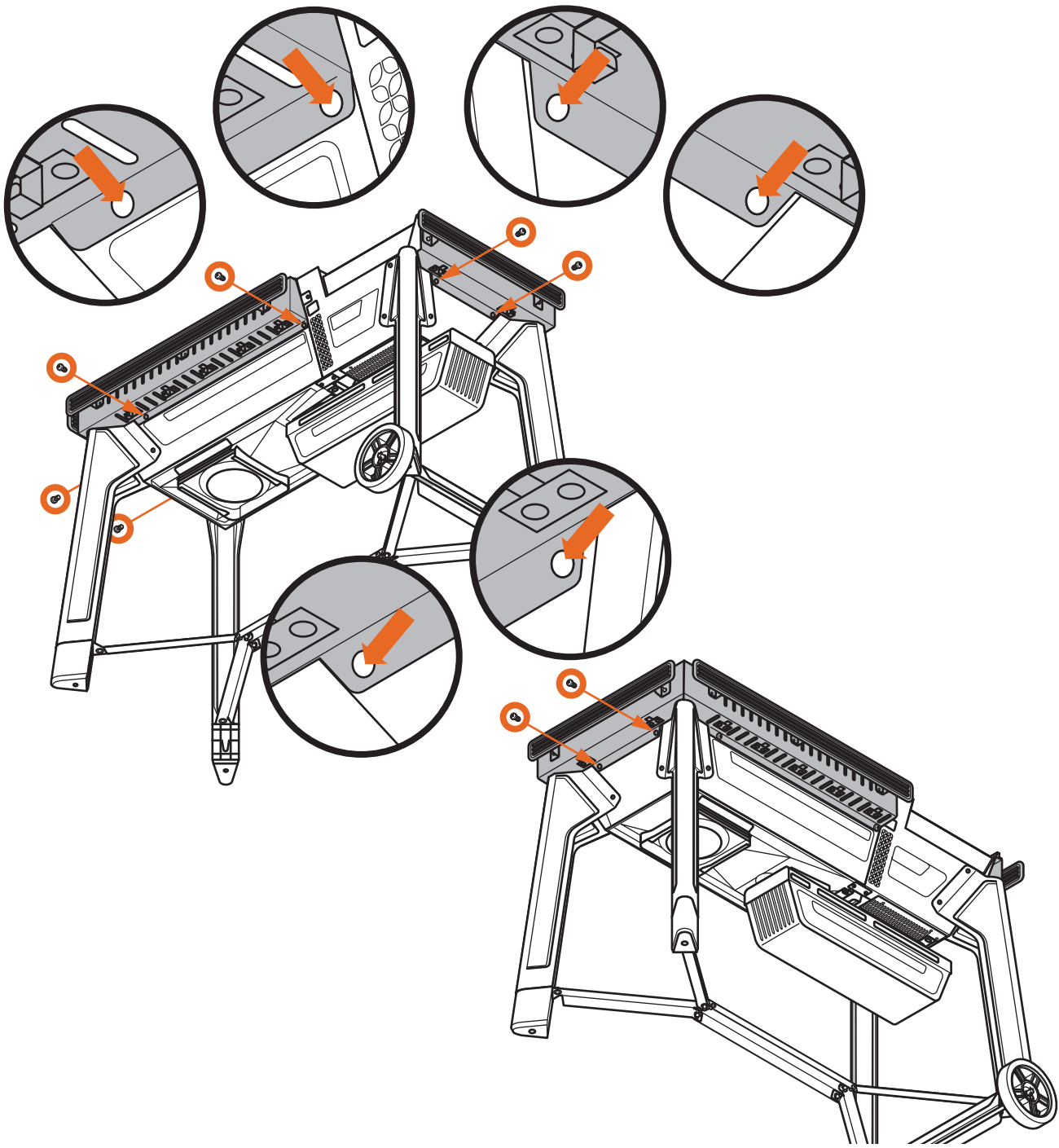

 **PRO TIP:** This step requires no hardware.

3 ASSEMBLE BACKSPLASH

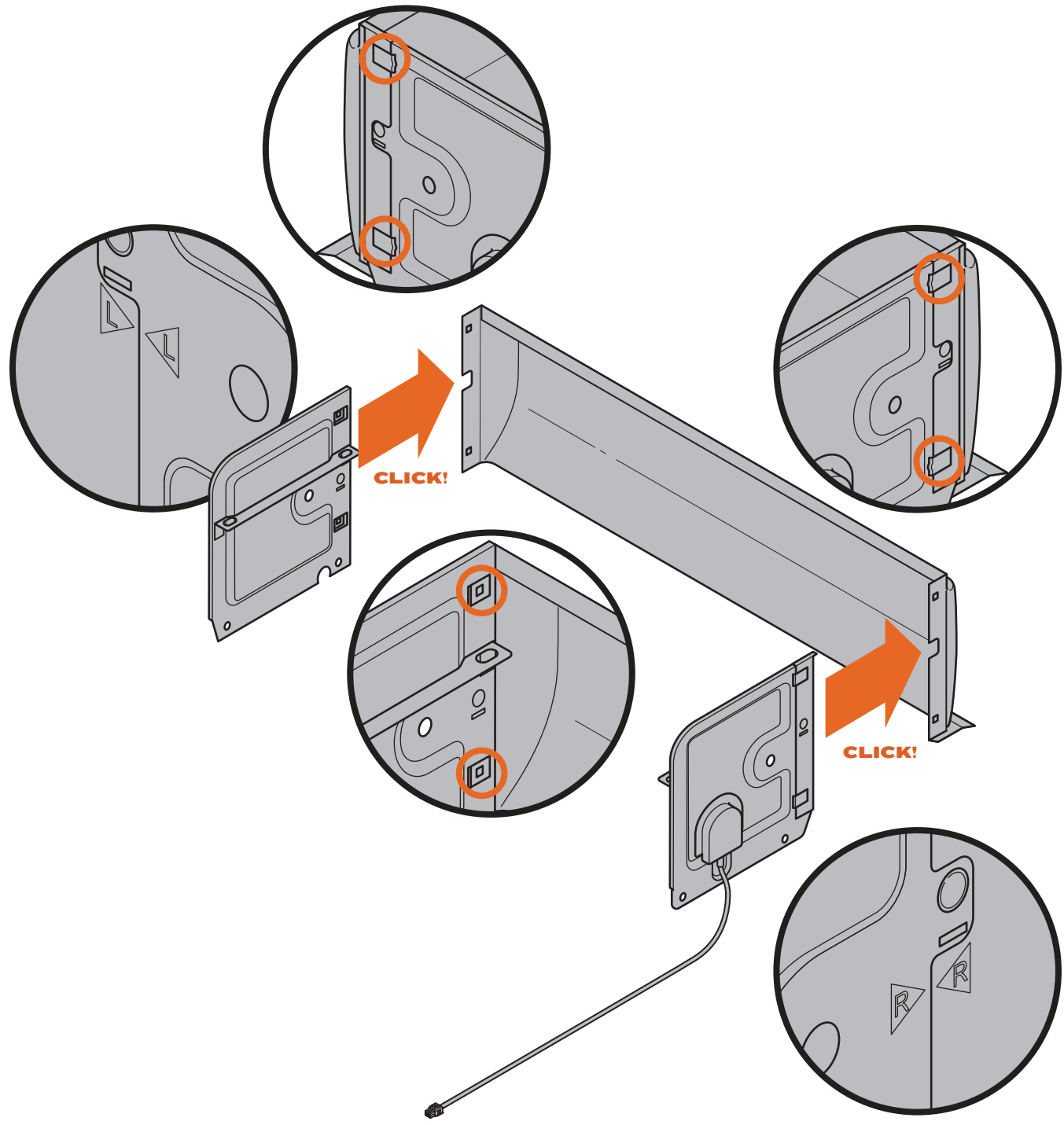
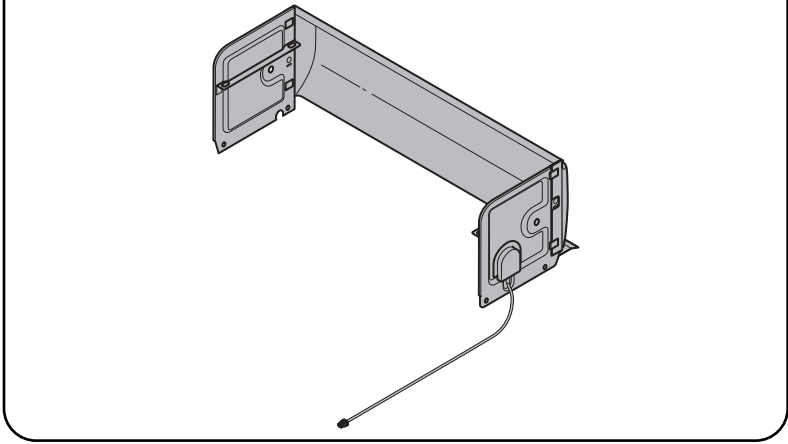



PRO TIP: Don't pinch the wire between the backsplash and the grill body! Also, slide the wire through the openings carefully to prevent damage!

4 ROUTE BACKSPASH WIRING

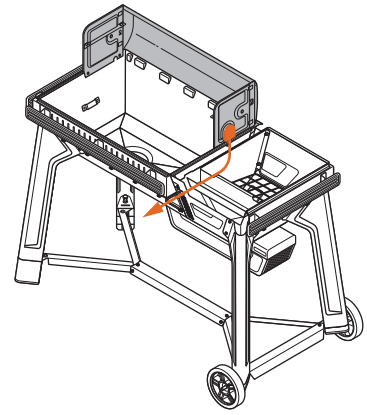

4A

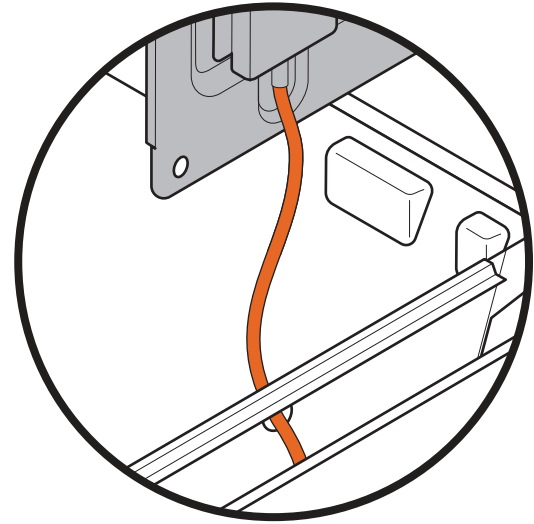
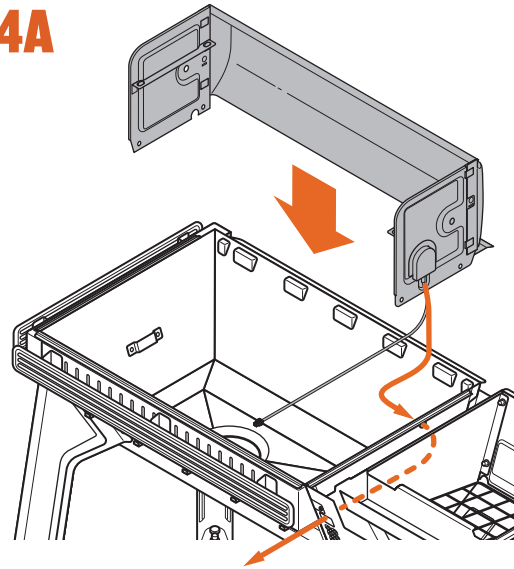

4B

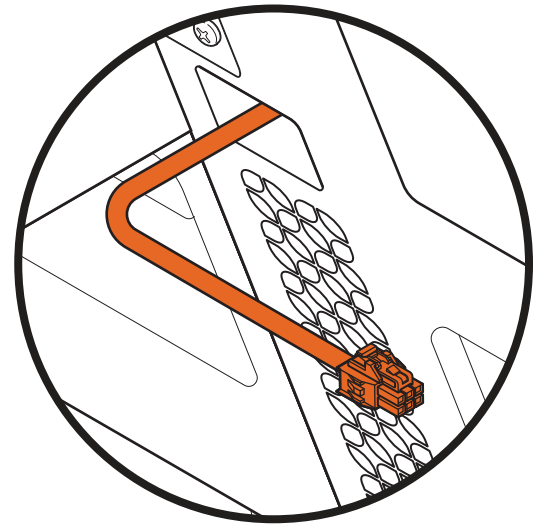
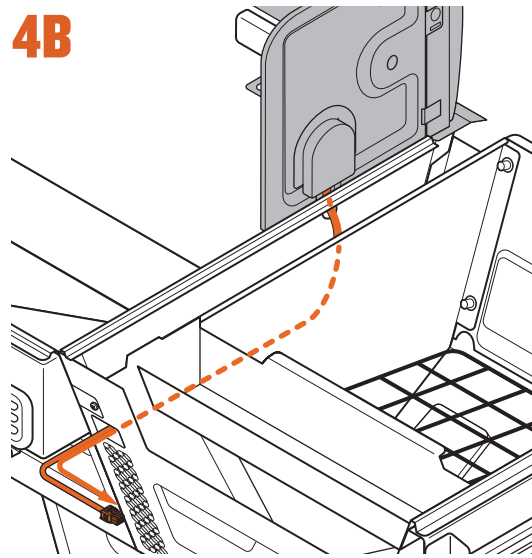



5 ATTACH BACKSPLASH

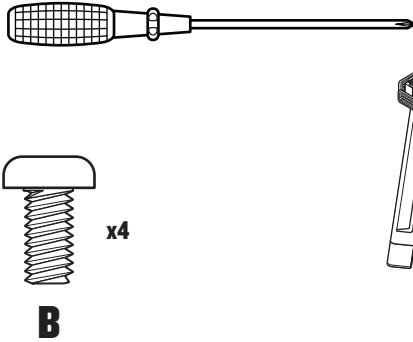

B x4

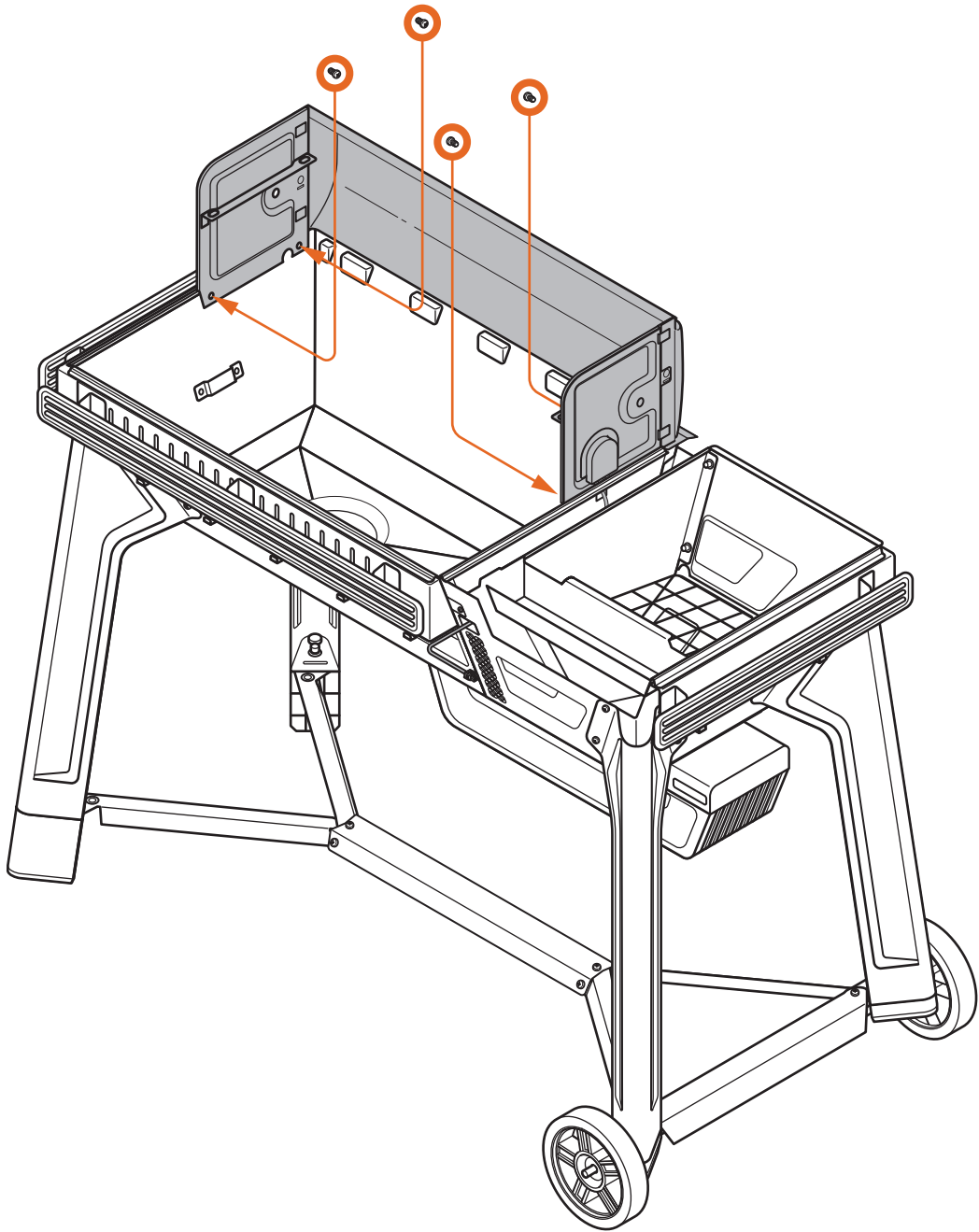
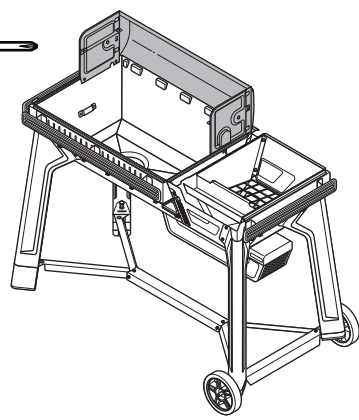



6 INSTALL REAR HOOKS

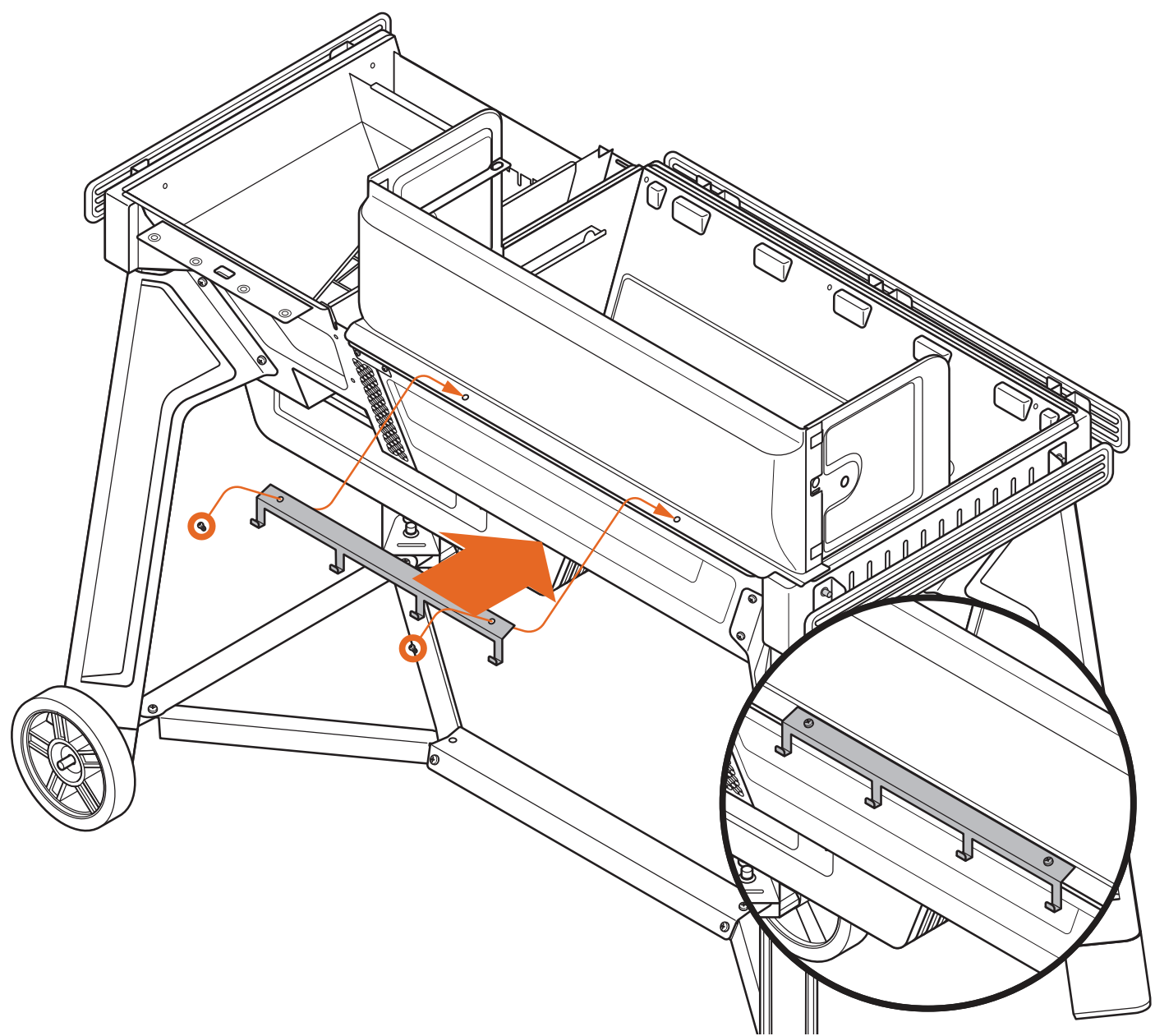
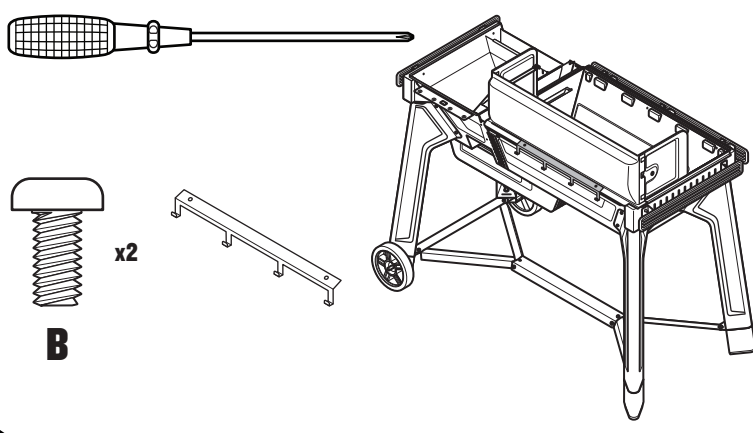



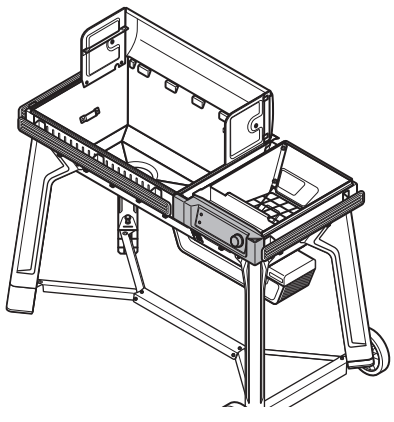
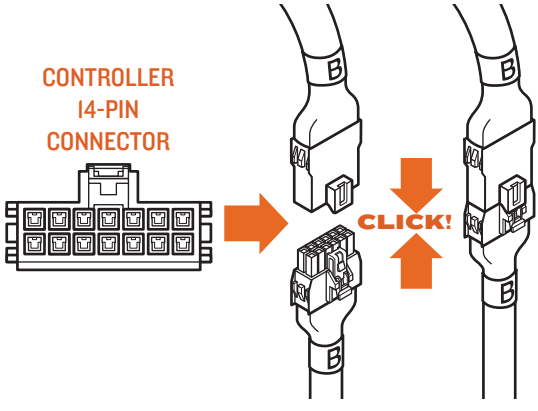

7 CONNECT CONTROLLER

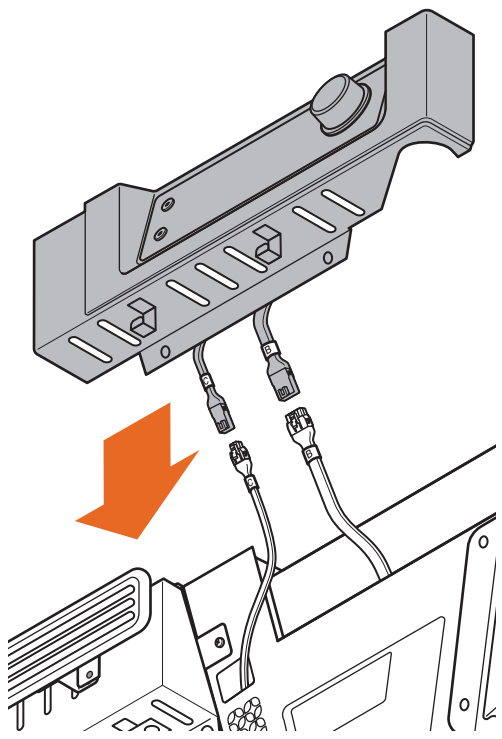

 **PRO TIP:** For easier connecting, lay the controller on its back on the edge of the hopper.



 **PRO TIP:** After connecting, tuck wires back into grill to prevent pinching them.

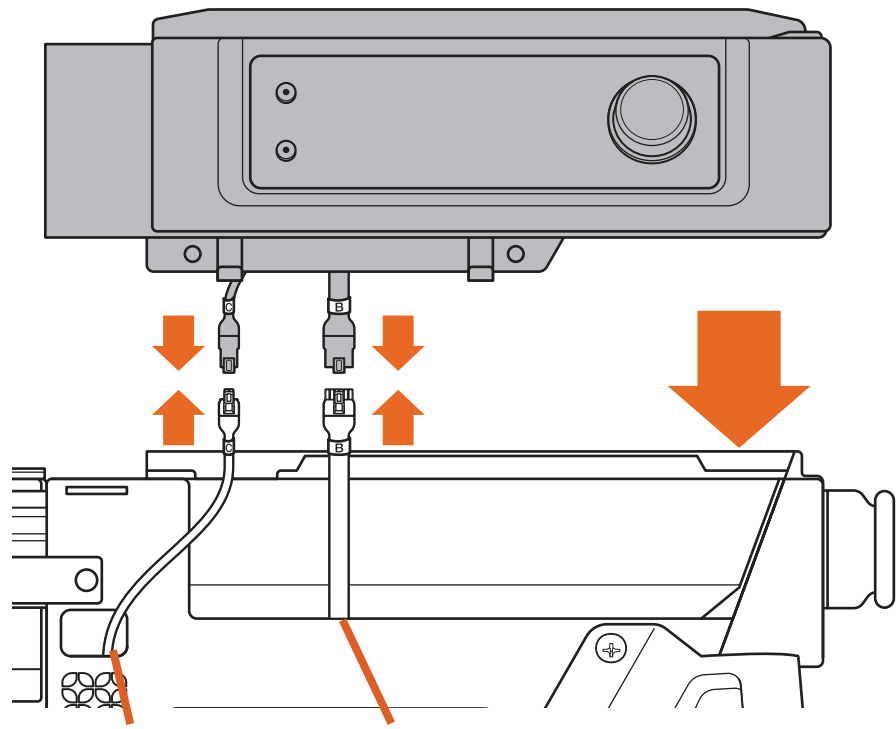

**TEMPERATURE SENSOR
4-PIN CONNECTOR**



**CONTROLLER
14-PIN CONNECTOR**



 **PRO TIP:** To more easily connect connector B, cut the zip tie holding it to the grill.



 **PRO TIP:** Install controller over flange in hopper.

8A ATTACH CONTROLLER

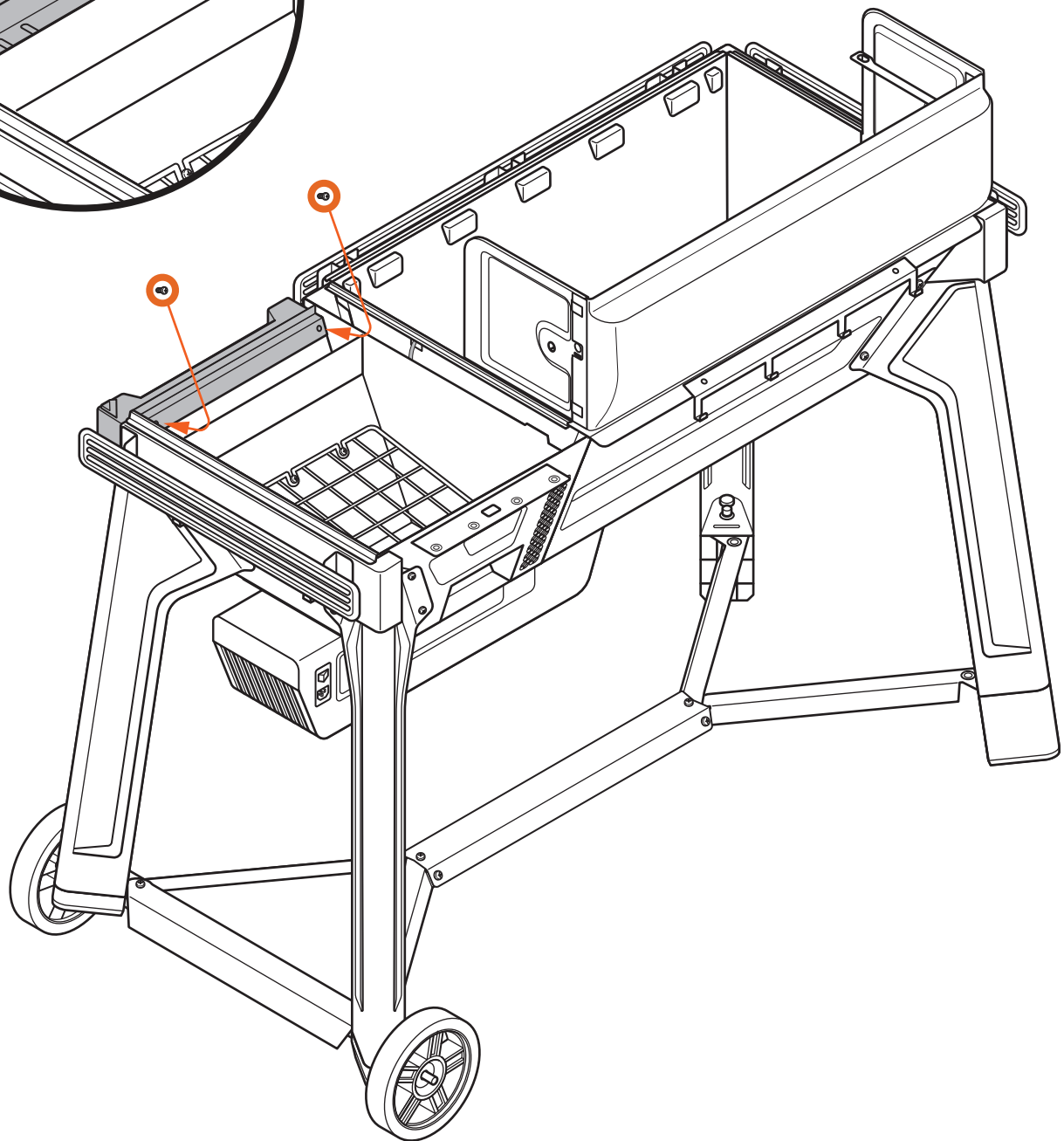
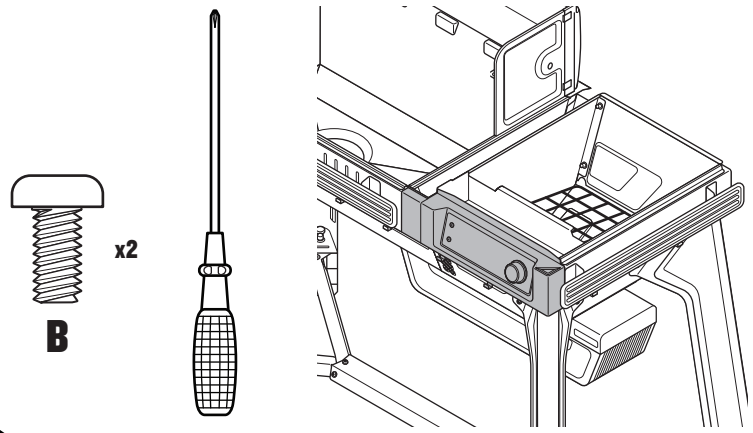
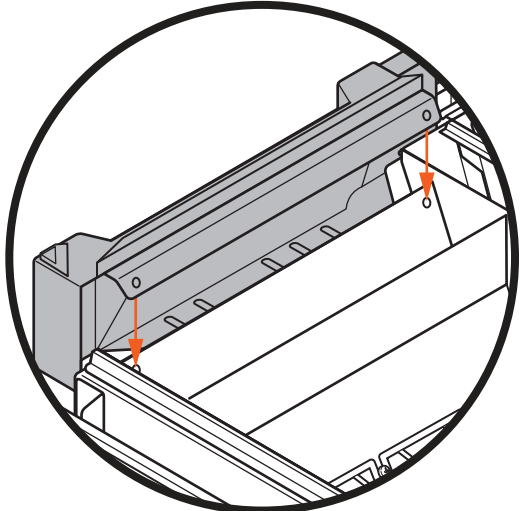



8B ATTACH CONTROLLER

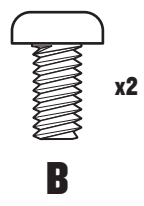

x2

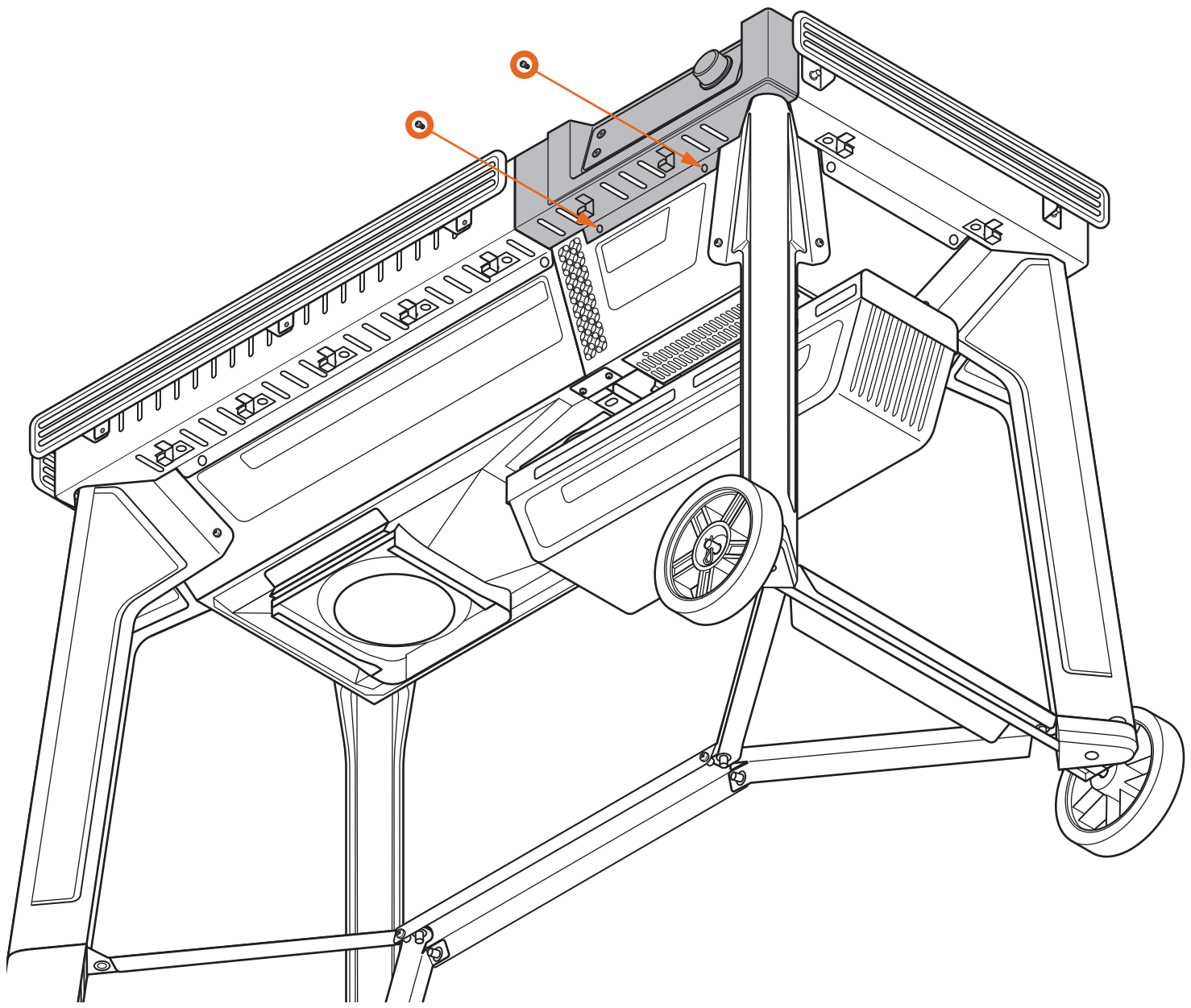
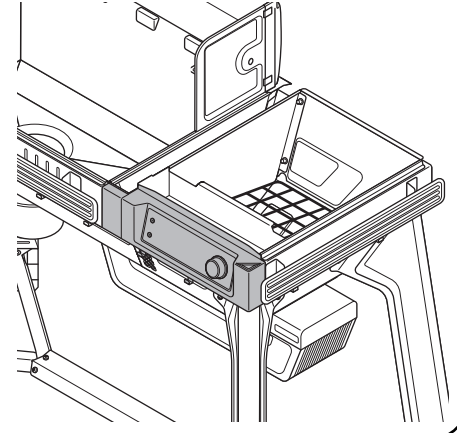
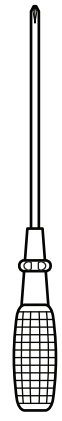

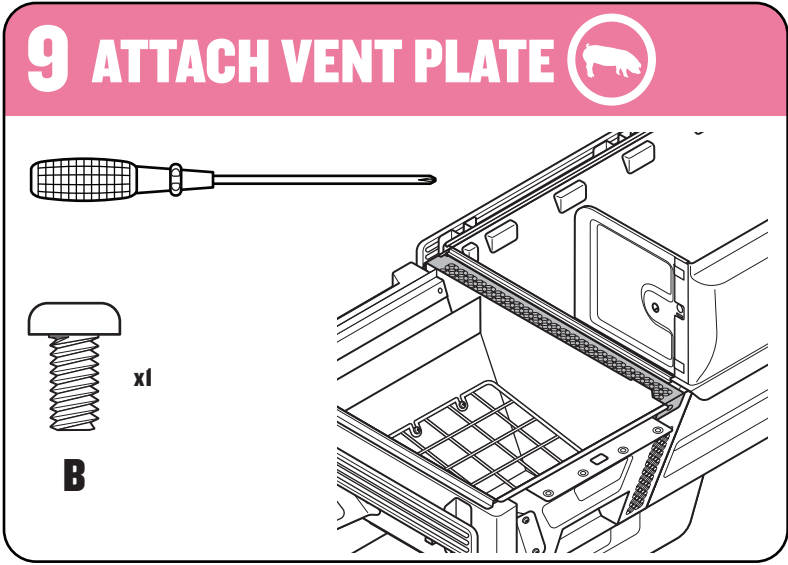

9A

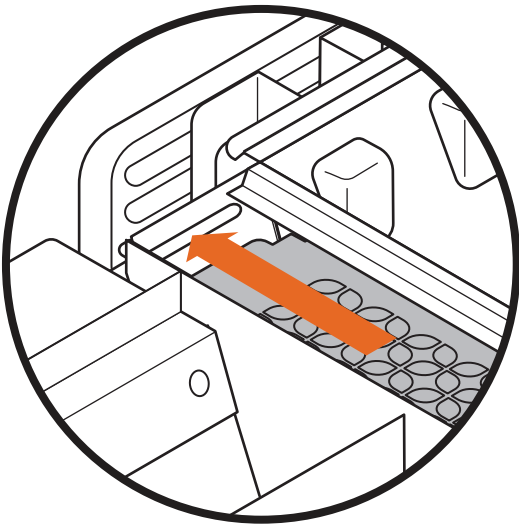

9B

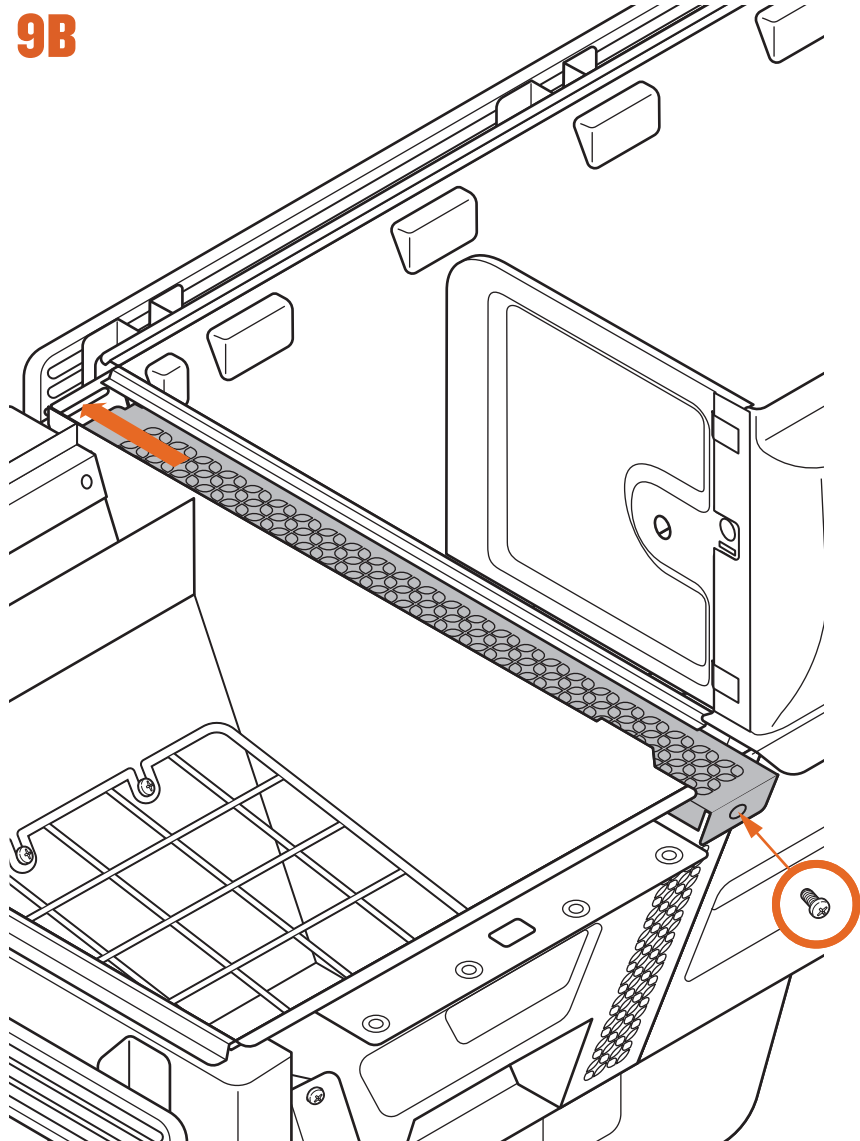

NICE WORK!
CHAPTER 3 COMPLETE!

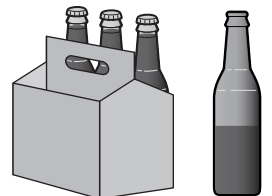

CHAPTER 4

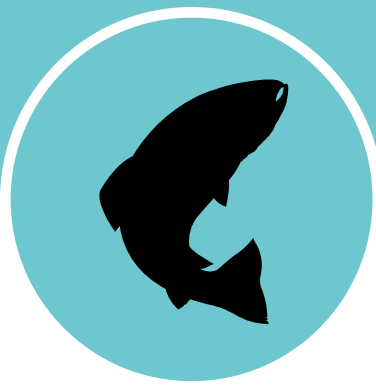
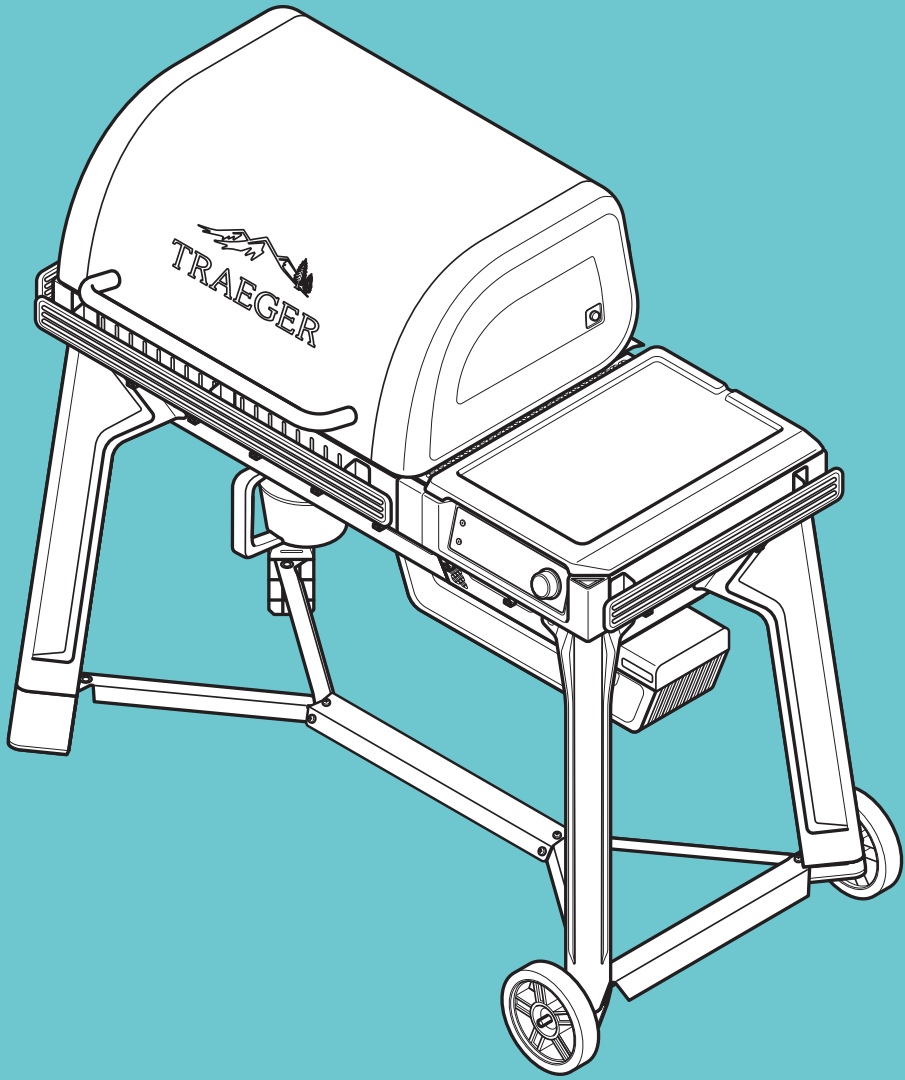

LID & GRILL INTERNALS

CHAPTER 4

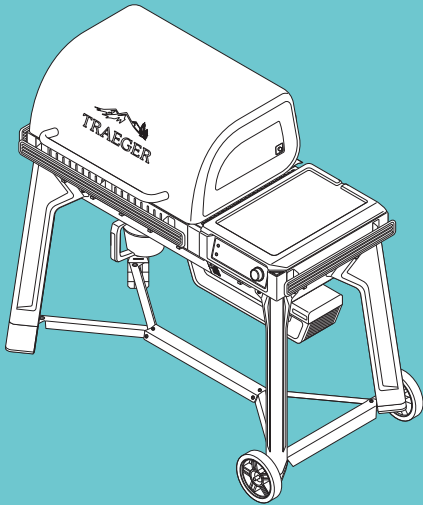

1 ATTACH HOPPER LID

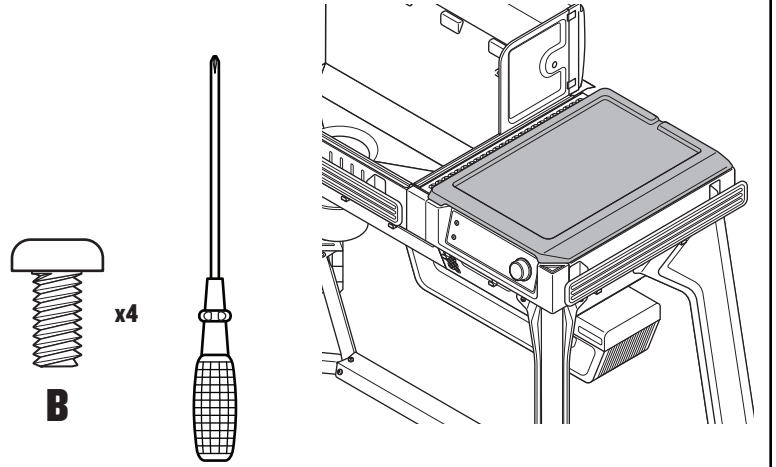

PRO TIP: Hand-tighten all screws first, then finish tightening with screwdriver.

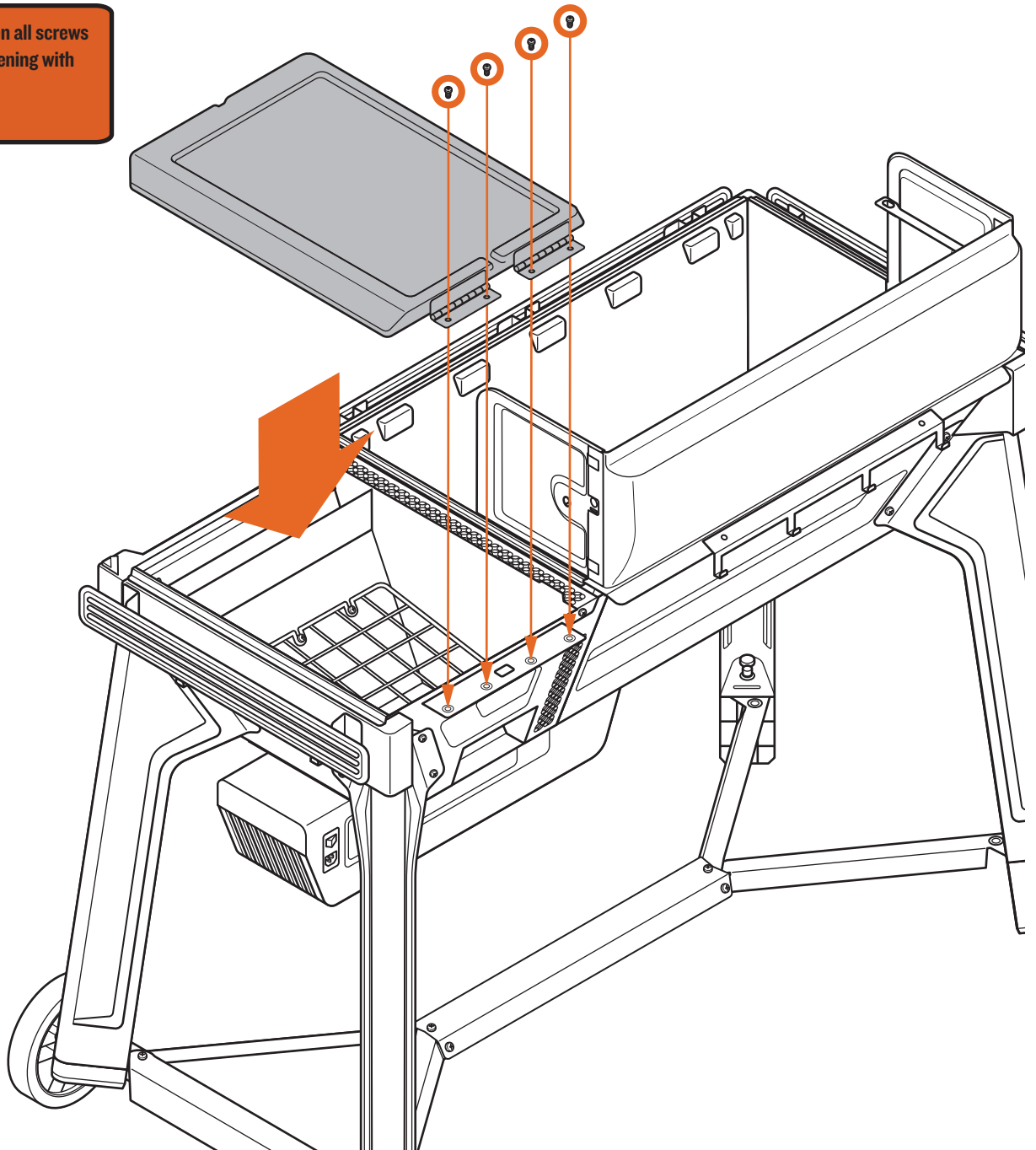



2A INSTALL CHUTE, SHIELD, AND BAFFLE

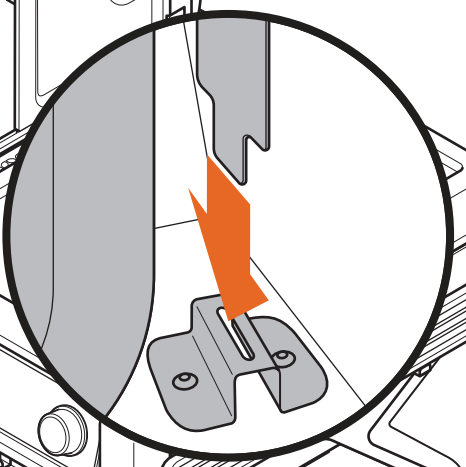
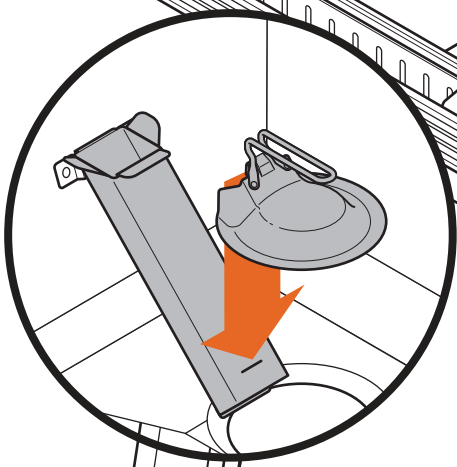
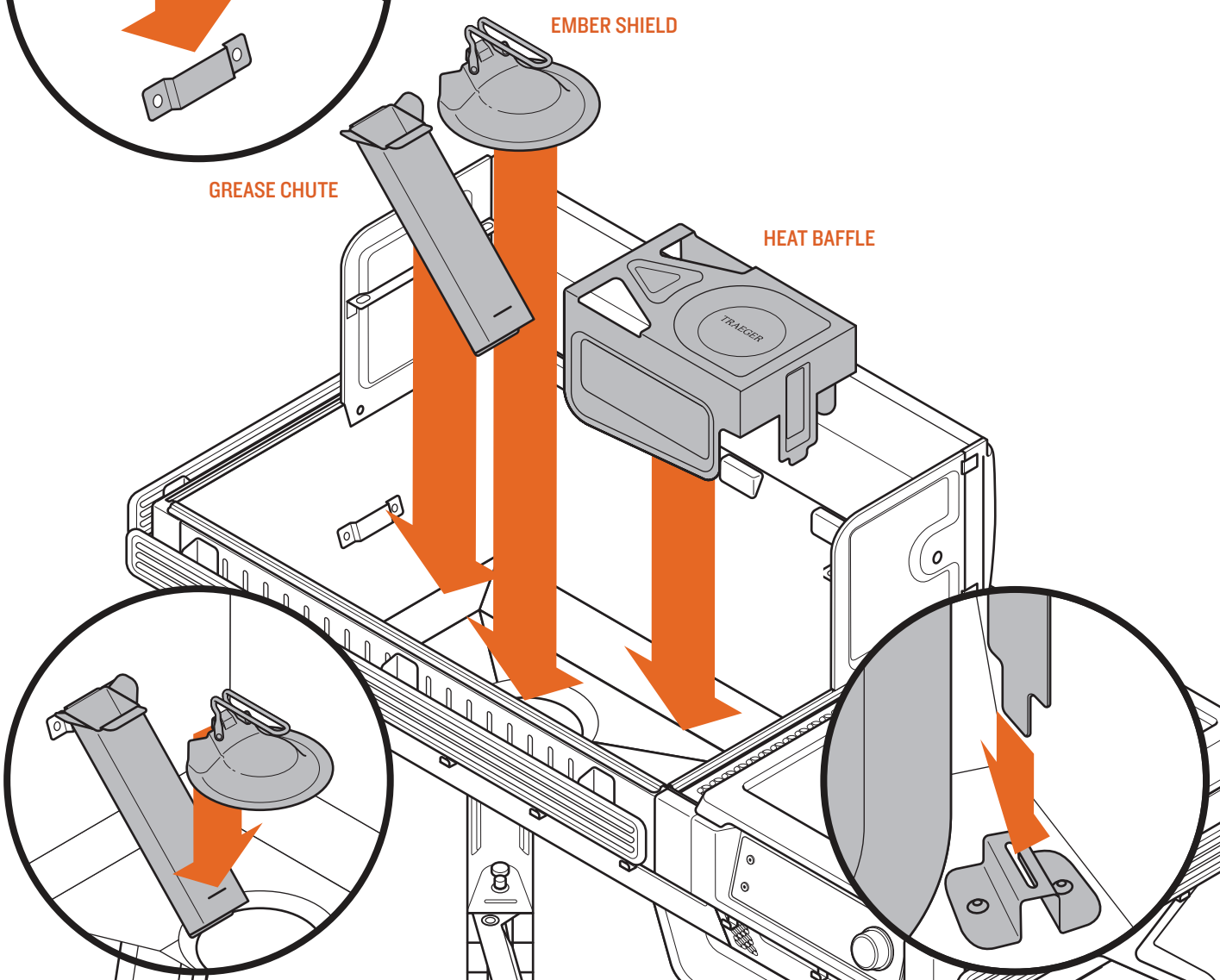
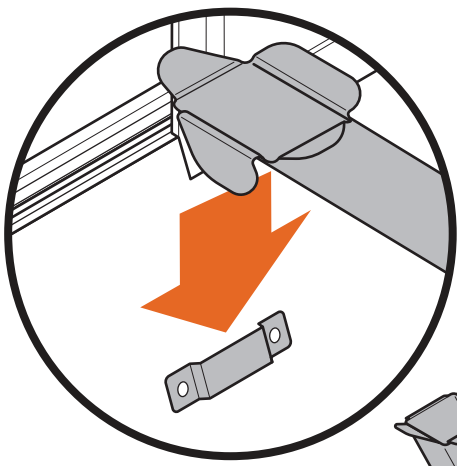
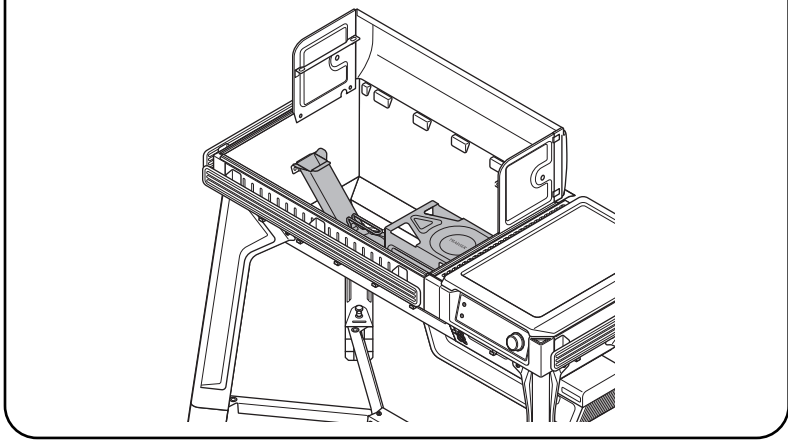
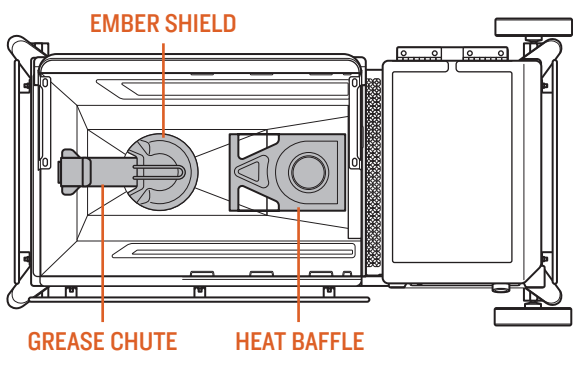



2B INSTALL DRIP TRAY

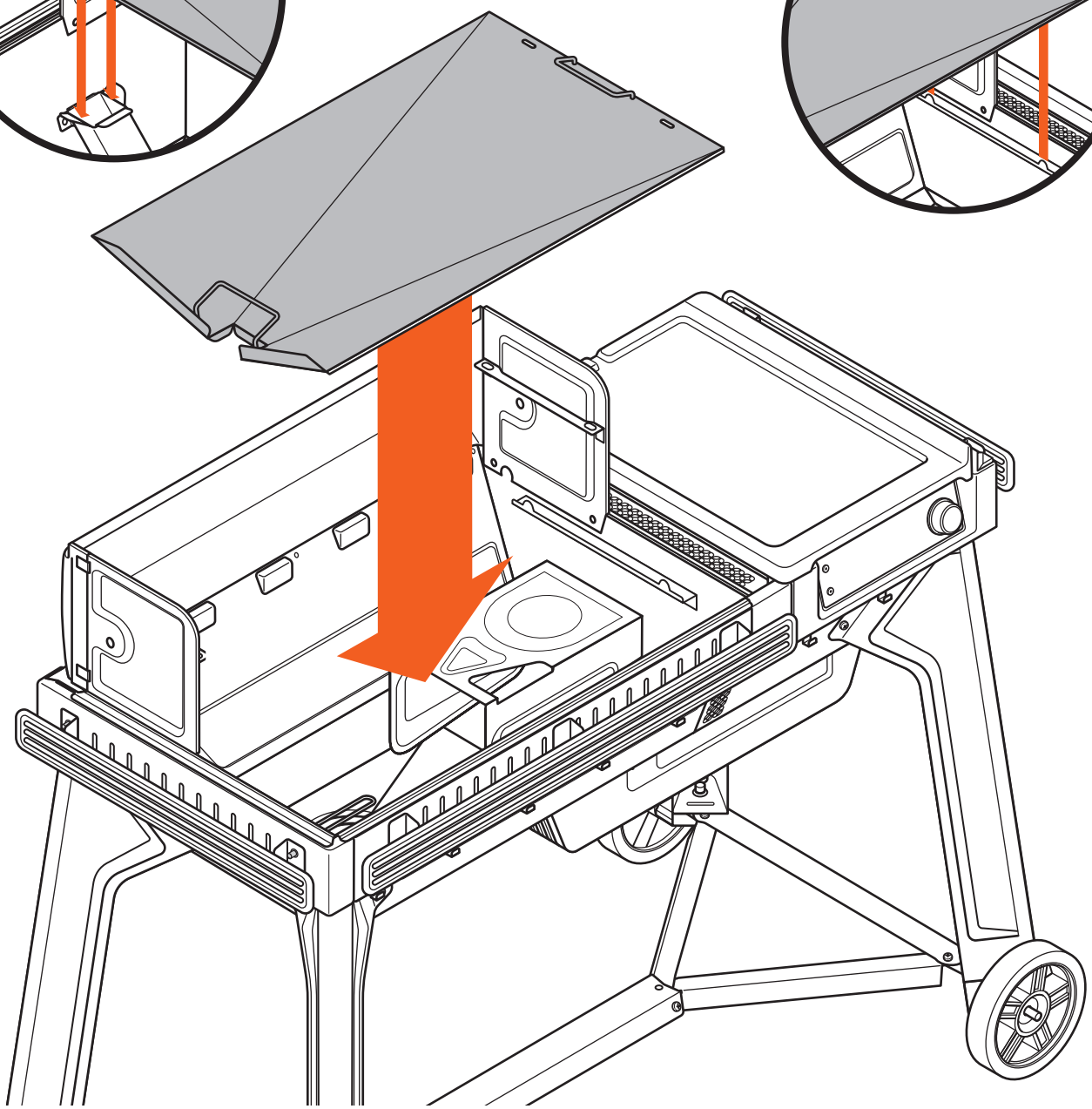
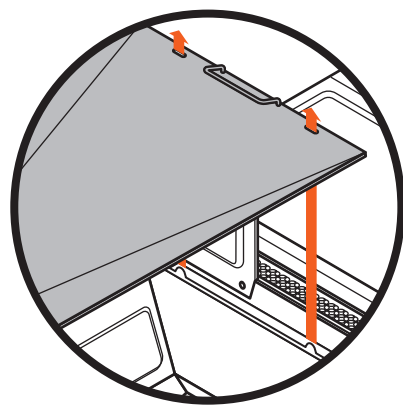
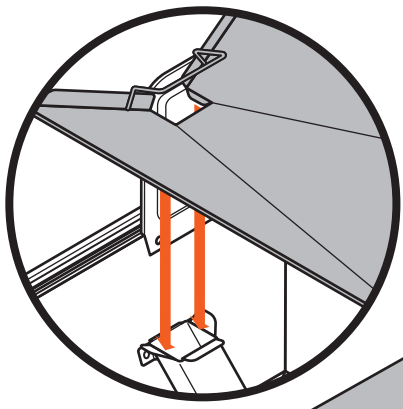
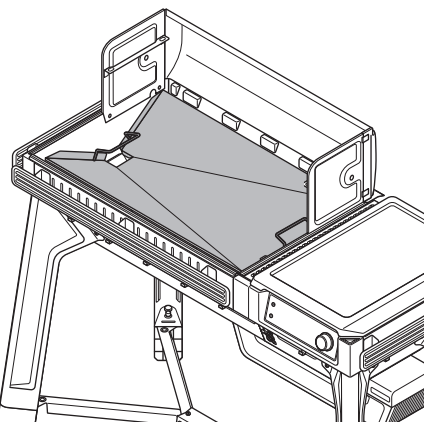



3A ATTACH LID HANDLE

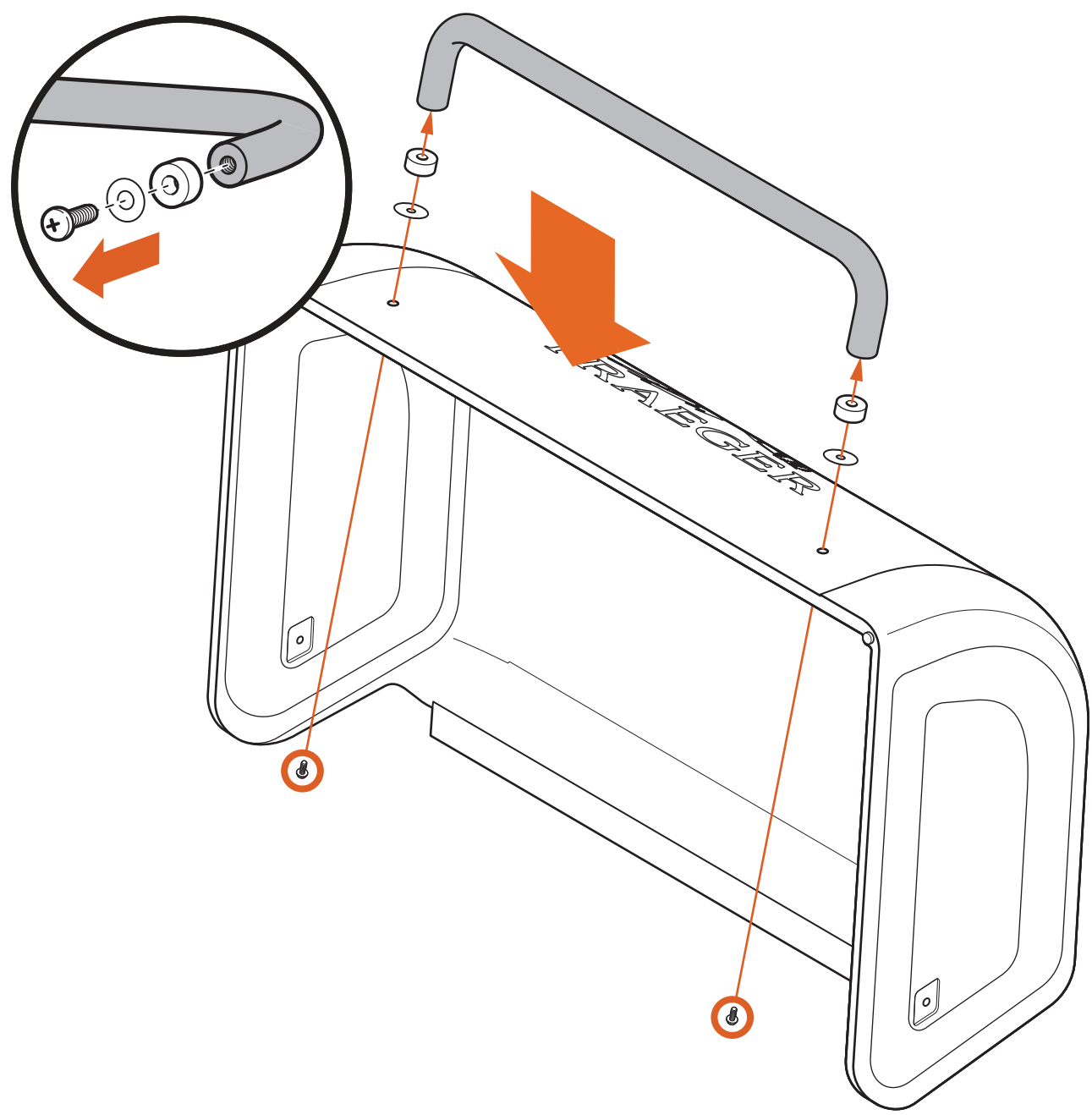
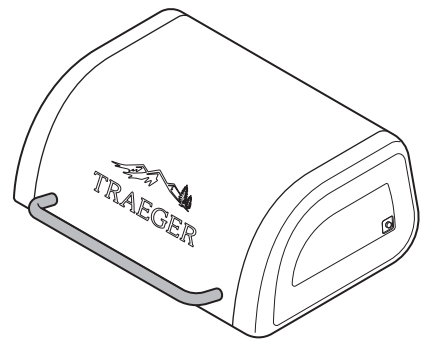
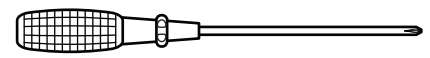



 **PRO TIP:** Use two people to attach the lid.

3B ATTACH LID

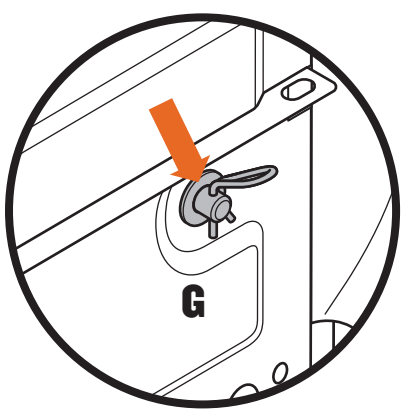
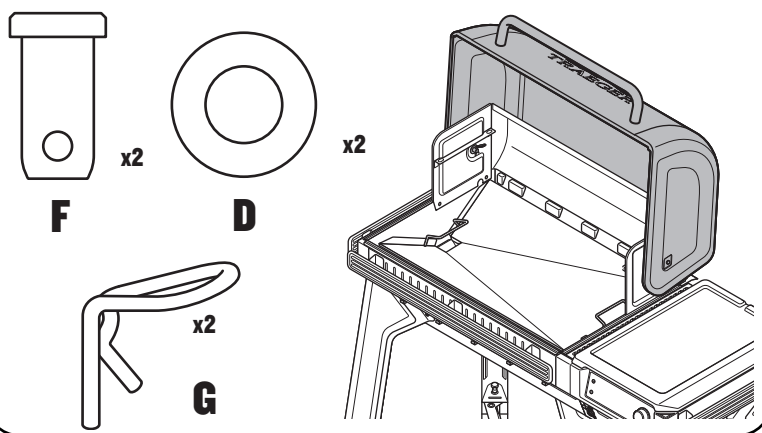

 **PRO TIP:** Attach clevis pins F with lid closed, then open lid to install G and D.

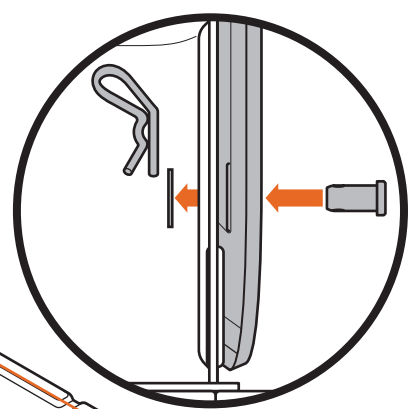
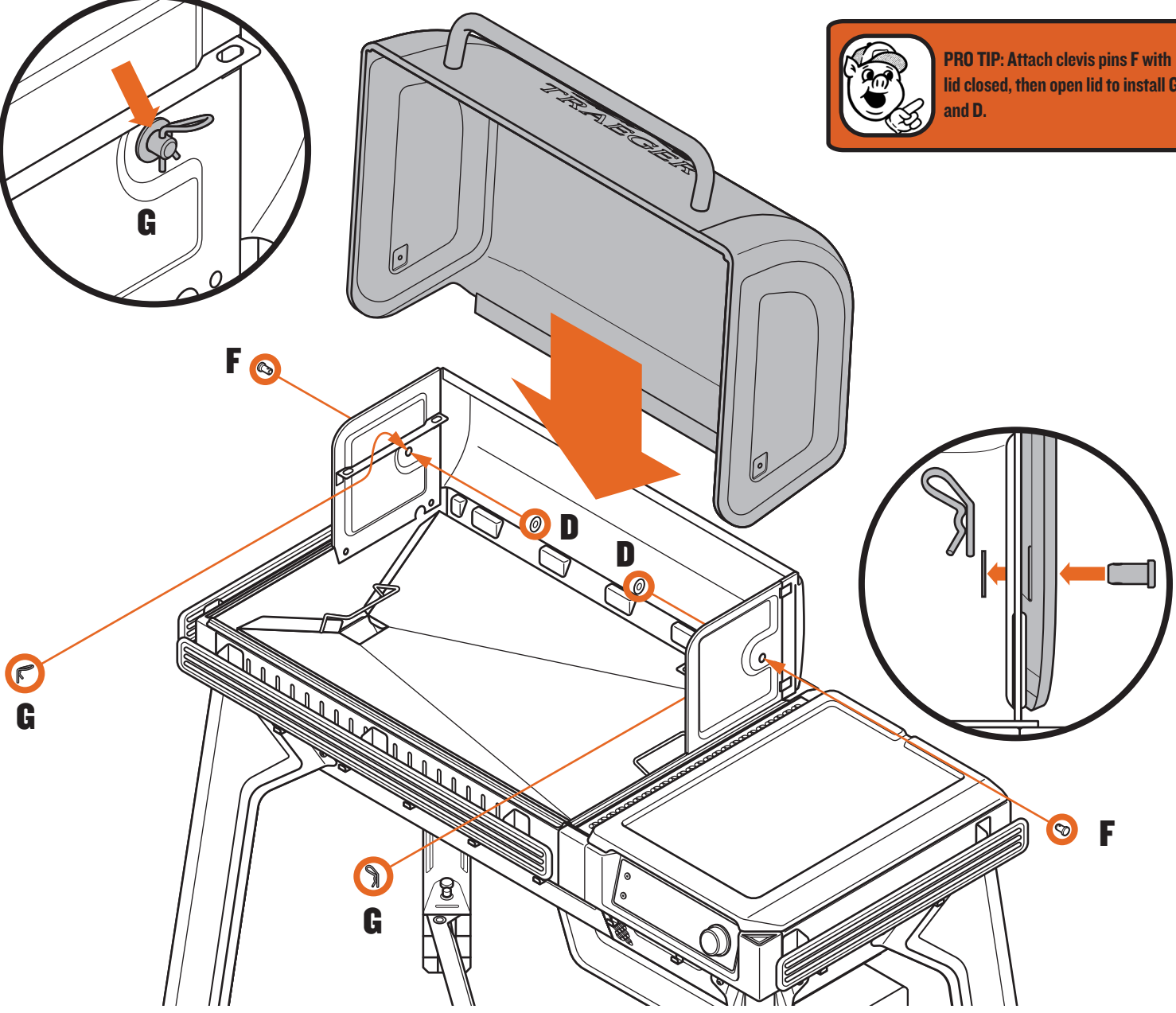



4 INSTALL GRATES

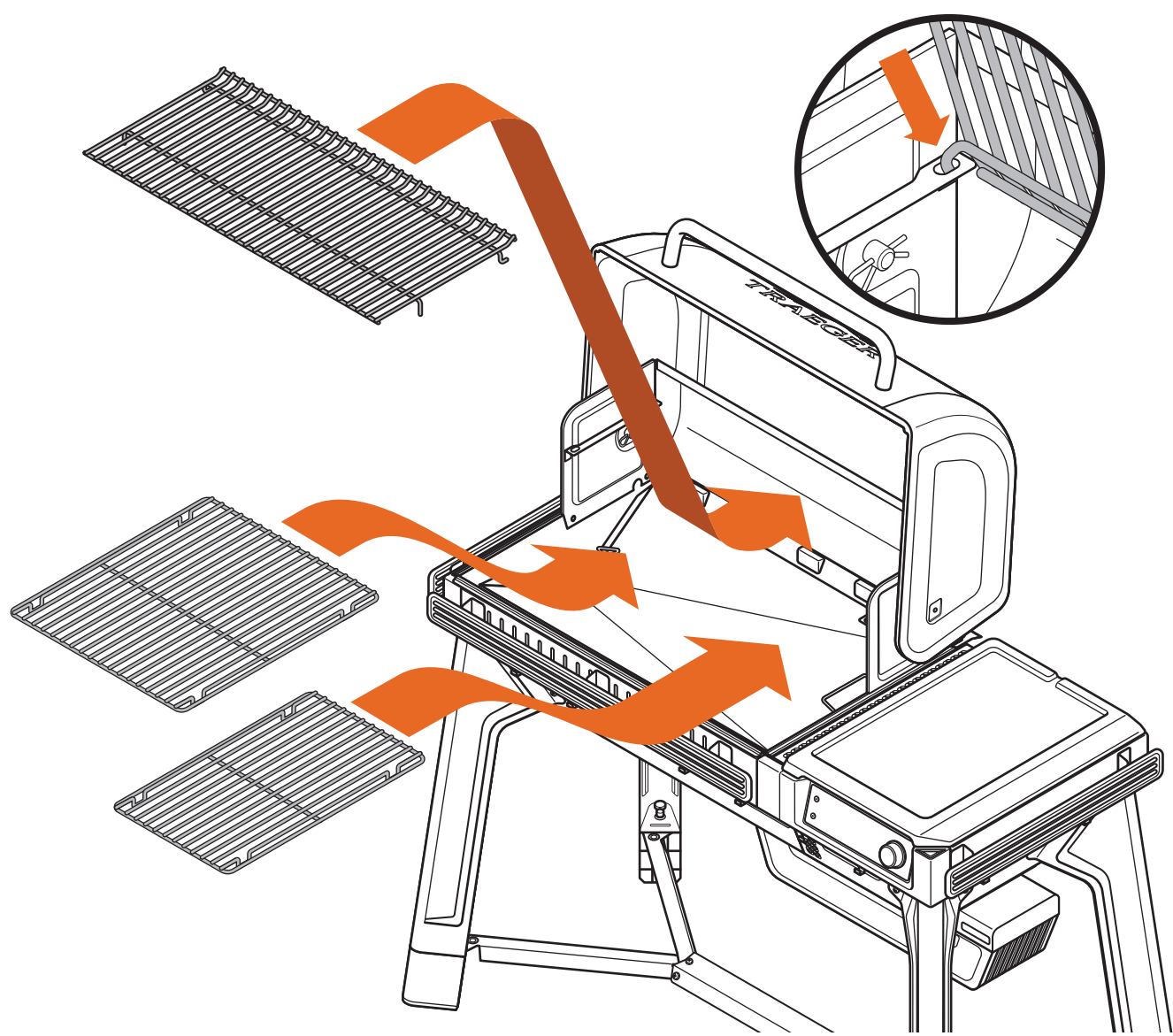
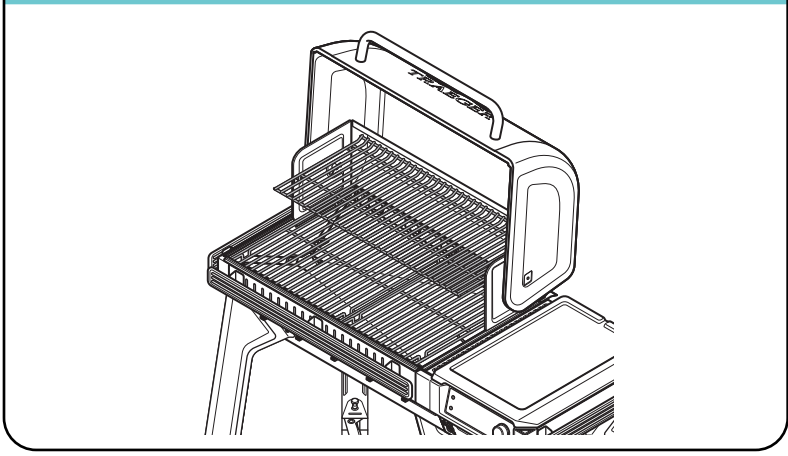



5 INSTALL GREASE + ASH KEG

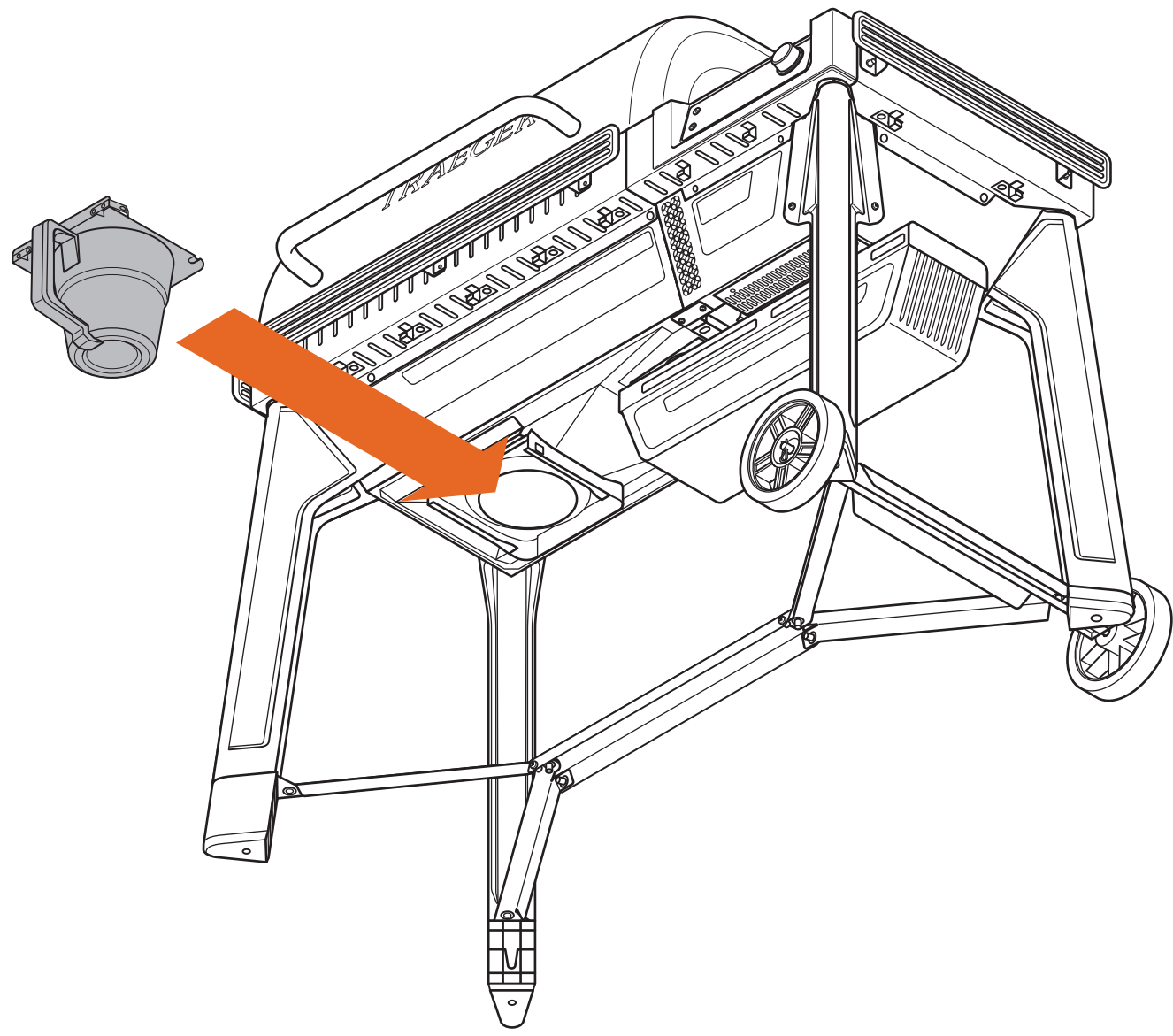
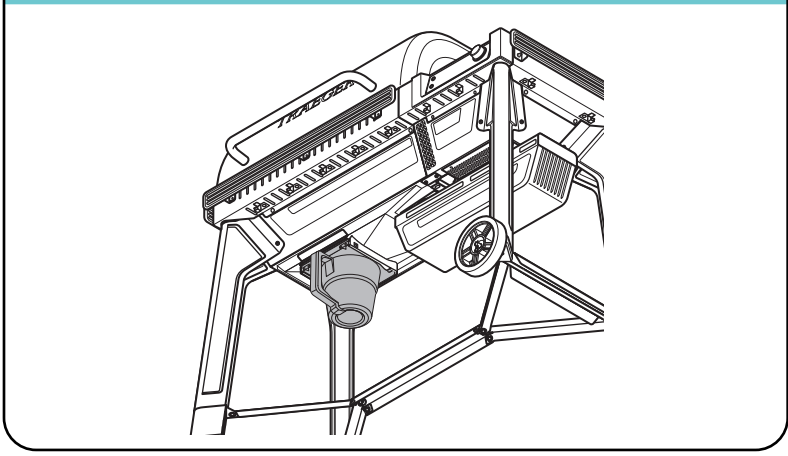



6 PLUG IN POWER CORD 

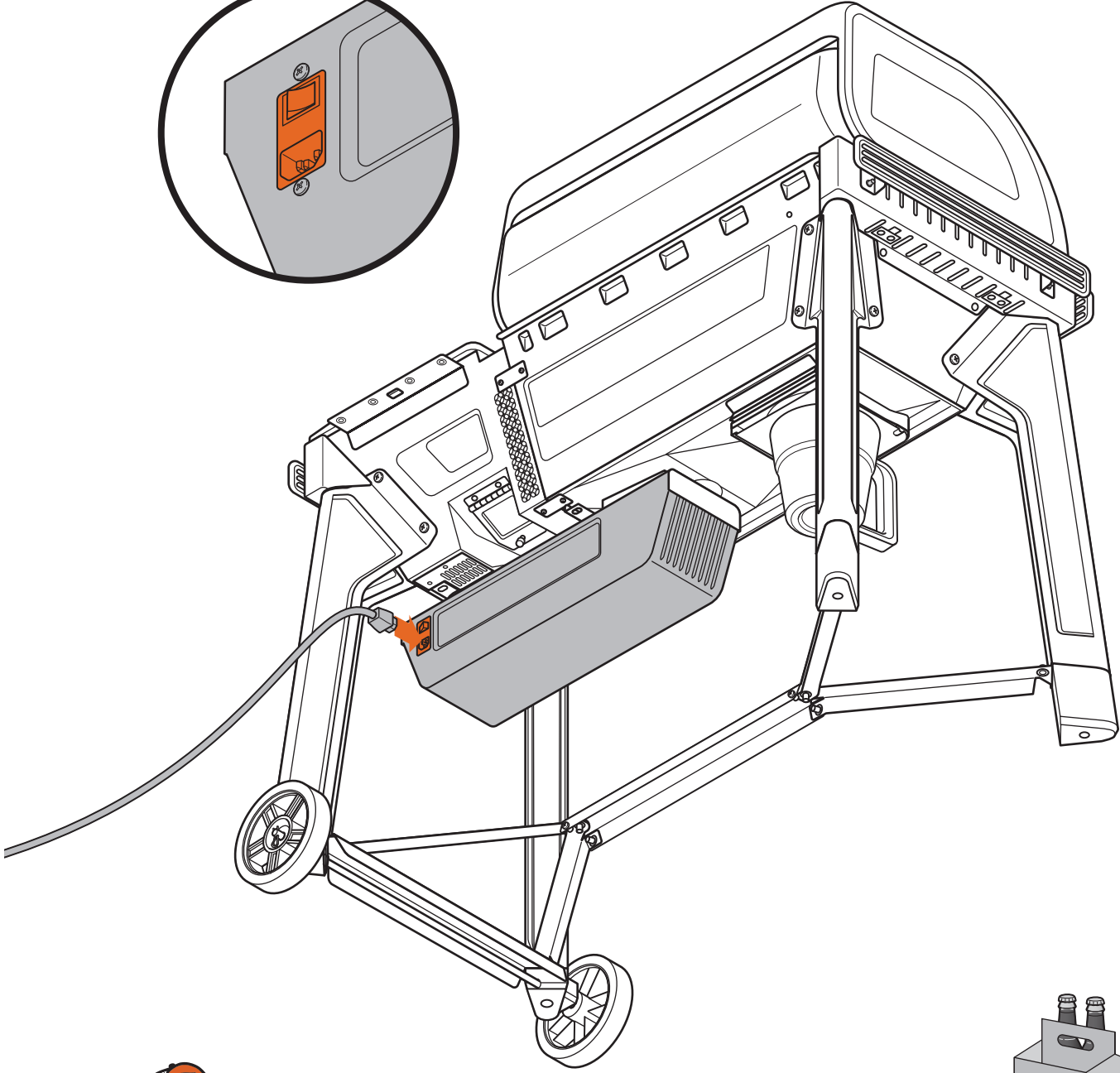
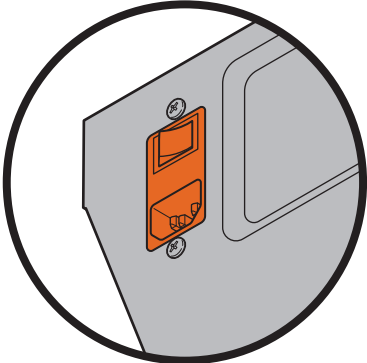
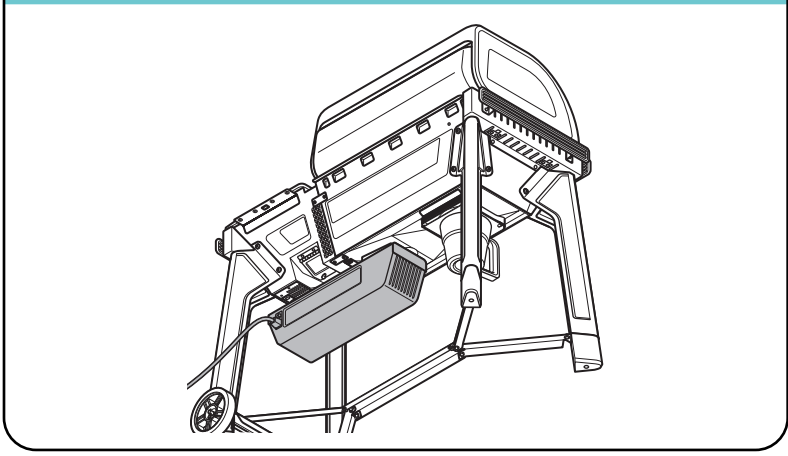

**NICE WORK!
CHAPTER 4 COMPLETE!**

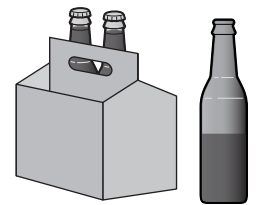

STORING PARTS AND ACCESSORIES

Wired Probe and Power Cord

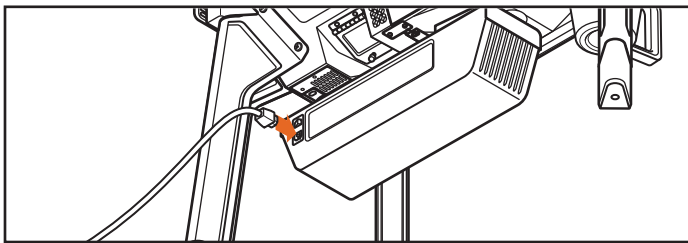
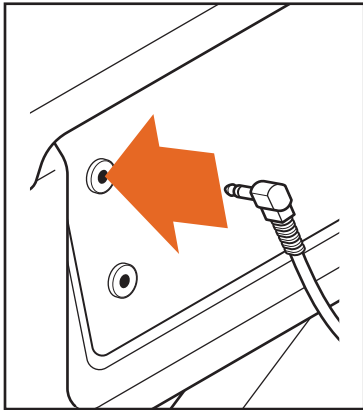

TO STORE:

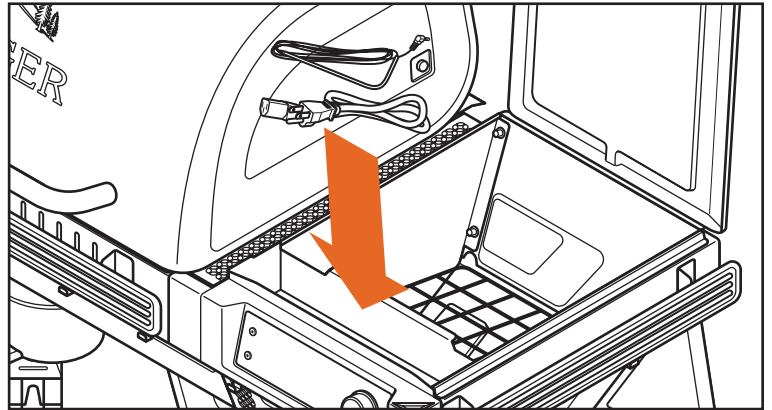

Grill Grates, Drip Tray, Grease Chute, and Ember Shield

TO STORE DURING CLEANING:

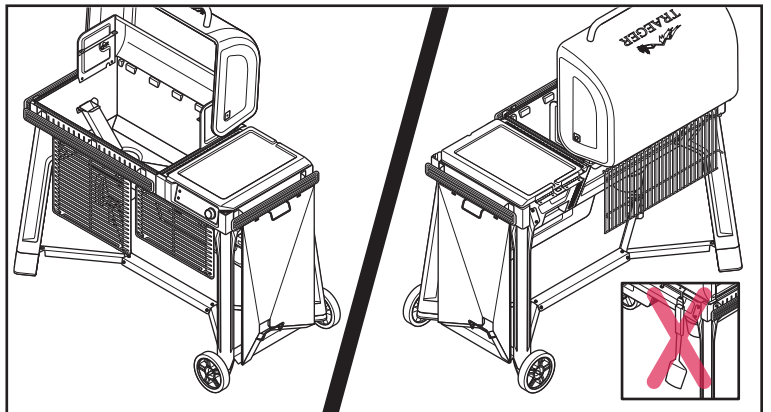
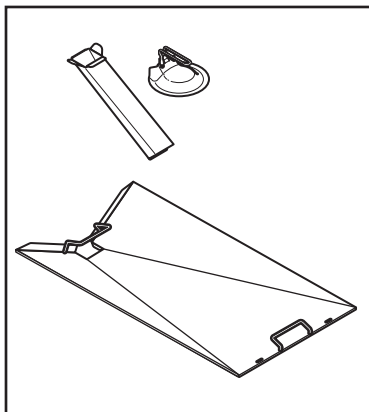
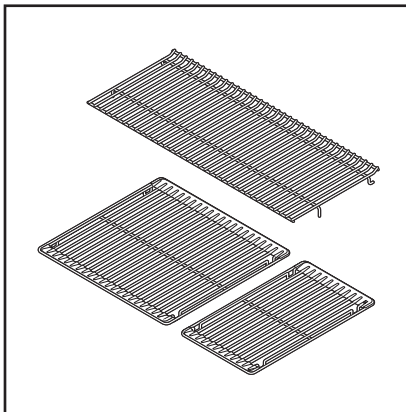

PRO TIP: Do not hang or store cooking utensils on grate hooks. Doing so could damage the utensils.

CONNECTING YOUR GRILL

Our dedication to delivering world-class products and experiences means we are constantly working to improve grill performance and features. We highly recommend connecting your Traeger® Woodridge™ Grill to WiFIRE® by following the instructions below. When your grill is connected and on, updates will automatically download, ensuring your grill is always operating at peak performance.

IMPORTANT:

- Make sure your smart device is running on the latest operating system and that Bluetooth® is turned ON.
- If using an Android device, turn on location services.
- To connect your grill to your home Wi-Fi, your grill must be powered on. Make sure the main power switch is pressed to ON (I) and lit up.
- Your home Wi-Fi router signal must be 2.4 GHz (a dual band router should also work). The 2.4 GHz band is currently industry standard for connected appliances. It has better range and penetrates walls/ceilings/obstacles better than 5 GHz, which your grill cannot recognize.

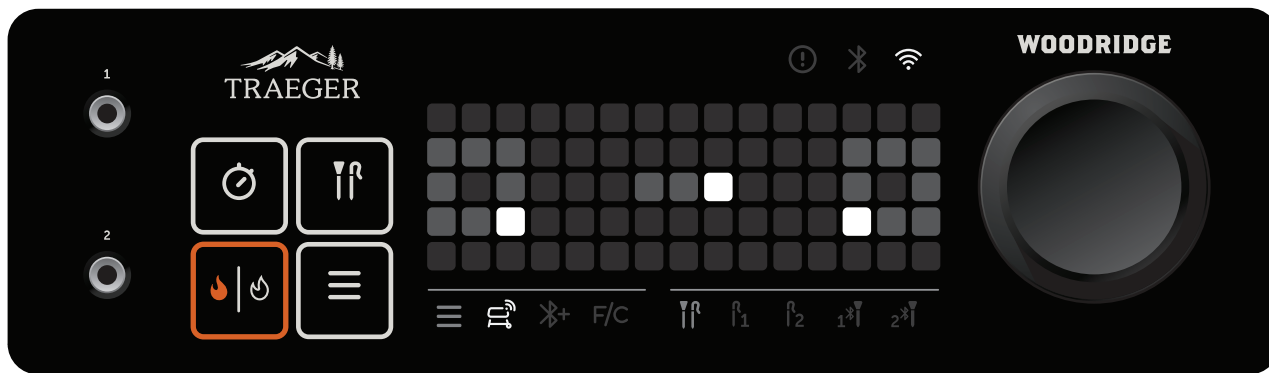

PRO TIP: Check under your hopper lid for a handy quick reference guide to your Woodridge™ controller!



Go to the Apple App Store or Android Google Play Store to download the latest version of the Traeger App.

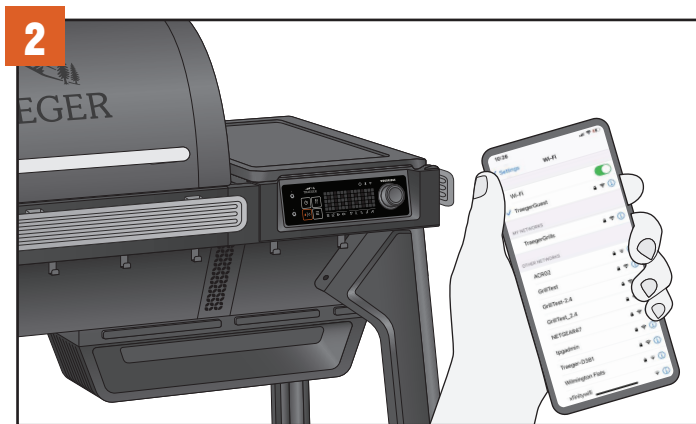

Ensure your smart device is connected to the Wi-Fi network to which you want your grill connected. The router signal must be 2.4 GHz, as the grill is not compatible with 5 GHz.

The Bluetooth® word mark and logos are registered trademarks owned by the Bluetooth SIG, Inc. and any use of such marks by Traeger Grills is under license. Other trademarks and trade names are those of their respective owners.

CONNECTING YOUR GRILL CONTINUED

3

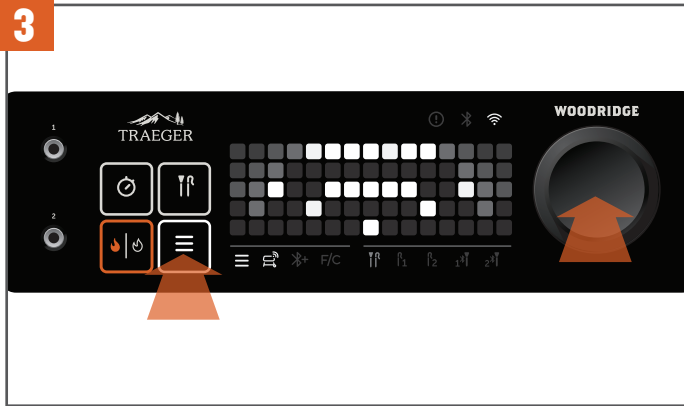

After powering on your grill, tap the menu button. You will see the Wi-Fi grill icon light up in the menu bar below the dot matrix, and an animation of a Wi-Fi signal with a question mark will be displayed. Press the selection dial to select this option and begin the connection process.

NOTE: You can navigate menu options by turning the selection dial after tapping the menu button. As you turn the dial, the menu bar icons below the dot matrix display will light up to indicate your selection.

4

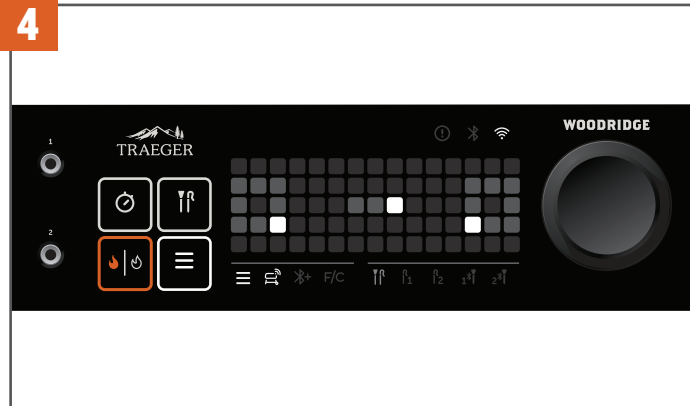

After selecting WiFIRE®, the pairing animation above will display on screen, indicating that your grill is broadcasting its Bluetooth® signal and is ready to pair. Open your smart device to the Traeger App and sign in to your account. On the home screen of the Traeger App, tap the grill icon in the lower center of the screen to start connecting.

Follow the instructions on the Traeger App to (1) pair your phone to your grill (via temporary Bluetooth® connection), (2) connect your grill to your desired 2.4 GHz home Wi-Fi network, and (3) complete the grill setup process.

5

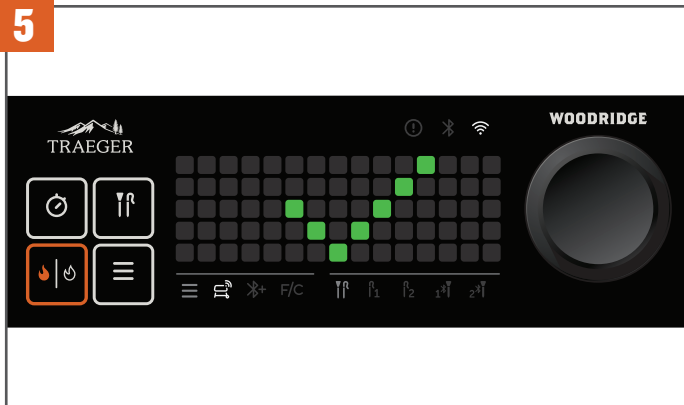

A green checkmark will display on your controller to indicate that you have successfully connected to WiFIRE®. The Wi-Fi icon in the top right above the matrix display will stay lit up when the grill is connected.

6

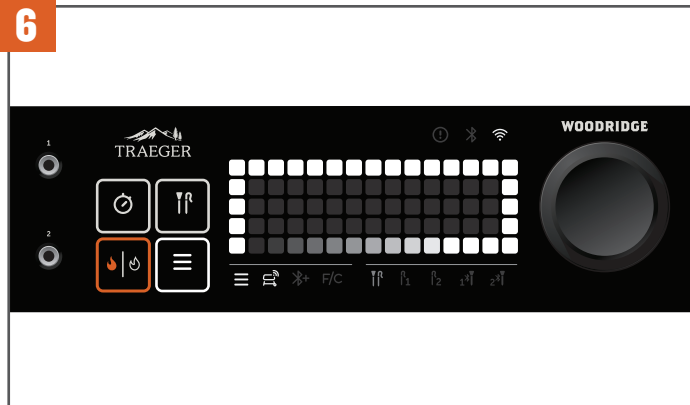

Once connected to WiFIRE®, you might see this animation on your screen. Don't turn off your grill until you see a green checkmark. This means that your grill is downloading and applying an update. Just like your smartphone, these updates keep your grill running smoothly, securely, and at peak performance. Once the update is done, you'll see a green checkmark and the grill will return to the idle mode – let's cook!

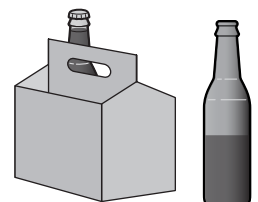

SEASONING YOUR GRILL

 **PRO TIP:** Seasoning must be completed before cooking food on your grill. For more information, scan here to access the Seasoning Guide.



Before you can cook on your grill, the grill must be seasoned. This is a hands-off process in which the empty grill gets heated to a very high temperature. This seasoning cycle ensures the grill is cleaned of any factory residue, primed, and ready for optimal performance.

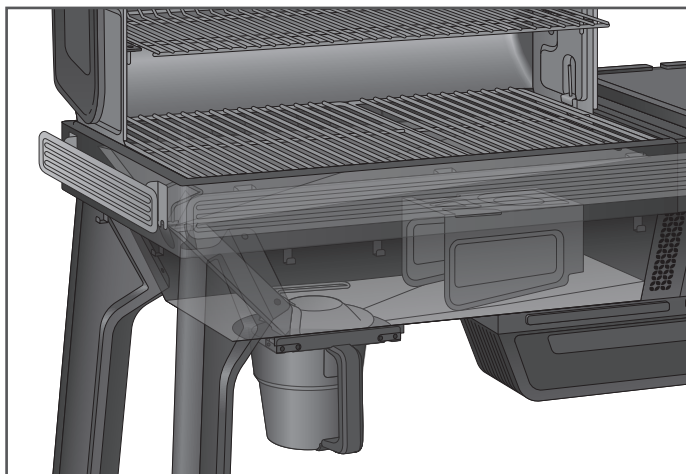

IMPORTANT:

- Make sure all components are properly installed in the grill and that all packaging/shipping materials are removed prior to seasoning.
- Do not wipe protective grease coating off of components before seasoning. This coating provides a more durable burn-in protective layer.

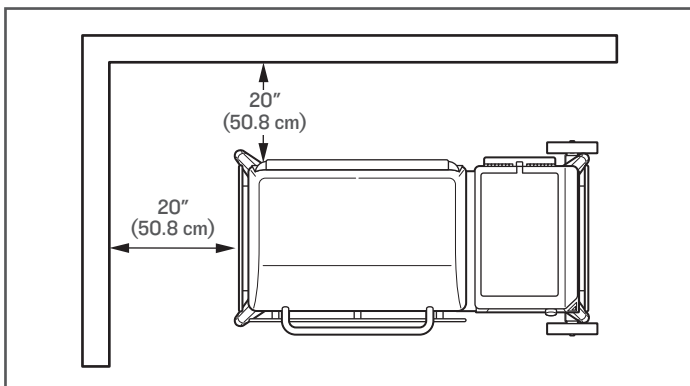

⚠️ WARNING Fire Hazard

- When operating your Traeger® Grill, maintain a **MINIMUM** distance of 20 inches (50.8 cm) from the grill to any nearby combustibles, including wooden railings, home siding, window frames, furniture, trees, trash receptacles, etc.

⚠️ DANGER Carbon Monoxide Hazard

Burning wood pellets produces carbon monoxide which may lead to illness, serious injury, and/or death. Follow these guidelines to prevent this colorless, odorless gas from poisoning you, your family, your pets, or others:

- Only use your Traeger® Grill outside in a well-ventilated area. This grill is intended for **OUTDOOR USE ONLY**.
- **Never** use your Traeger® Grill in any enclosed area or any area without adequate ventilation.
- Know the symptoms of carbon monoxide poisoning: headache, dizziness, weakness, nausea, vomiting, sleepiness, and confusion. Carbon monoxide reduces the blood's ability to carry oxygen. Low blood oxygen levels can result in loss of consciousness and death.
- See a doctor if you or others develop cold- or flu-like symptoms while cooking or in the vicinity of this appliance. Carbon monoxide poisoning, which can easily be mistaken for a cold or flu, is often detected too late.
- Alcohol consumption and drug use increase the effects of carbon monoxide poisoning.
- Carbon monoxide is especially toxic to mother and child during pregnancy, infants, the elderly, smokers, and people with blood or circulatory system problems, such as anemia or heart disease.

⚠️ WARNING Fire Hazard

- **Never** use gasoline, lantern fuel, kerosene, lighter fluid, or other flammable materials to start or "freshen up" a fire.
- **Never** use or store flammable liquids or other combustibles materials near the grill.

⚠️ WARNING Burn Hazard

Ashes should always be completely cool before handling. Ashes should be placed in a metal container with a tight-fitting lid. The closed container of ashes should be placed on a noncombustible floor or on the ground, well away from all combustible materials, pending final disposal. Ashes should be retained in the closed container until they are disposed of.

⚠️ WARNING Do Not Use Fuel Pellets

Never use heating fuel pellets in the grill because they may contain hazardous contaminants and additives and may damage the grill.

SEASONING YOUR GRILL CONTINUED

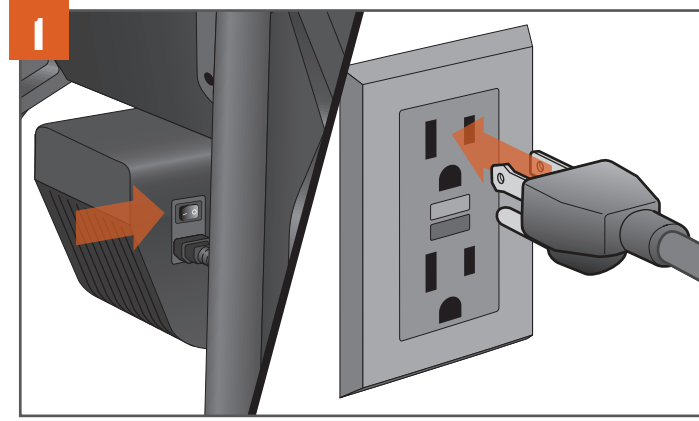

With the main power switch set to OFF (0), connect the power cord to your grill. Then plug the power cord into a properly grounded/earthed electrical outlet protected by a Ground Fault Circuit Interrupter (GFCI).

NOTE: Plug appearance may vary by region.

WARNING! ELECTRICAL SHOCK HAZARD
HAZARDOUS VOLTAGE IS PRESENT, WHICH CAN SHOCK, BURN, OR CAUSE DEATH.

- GROUND FAULT CIRCUIT INTERRUPTER (GFCI) PROTECTION MUST BE PROVIDED ON THE CIRCUIT(S) OR OUTLET(S) TO BE USED FOR THE OPERATION OF THIS TRAEGER® GRILL.

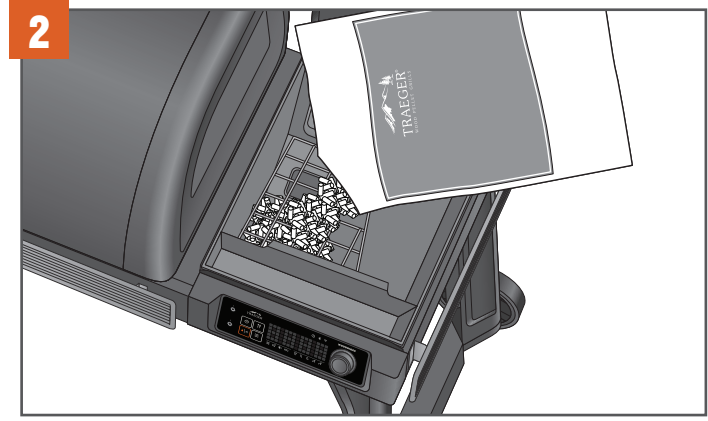

To add pellets, open the hopper lid and inspect for any foreign objects in the auger. Fill the hopper with pellets at least to the safety grate and close the lid.

USE ONLY TRAEGER HARDWOOD PELLETS. This product is developed and tuned using only Traeger pellets. Traeger pellets are crafted to meet strict quality and performance standards. Using pellets not manufactured by Traeger may result in inconsistent performance, poor flavor, and temperature inconsistency.

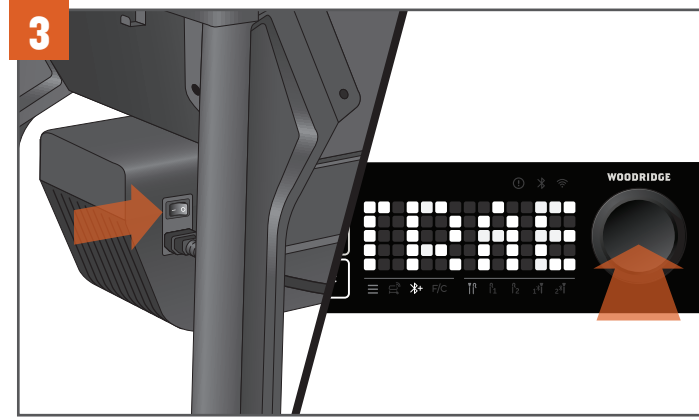

Press the main power switch, located on the back of the auger box, to ON (I). Press the selection dial to wake up the controller. "TRAEGER" will scroll across the screen, indicating the grill is on.

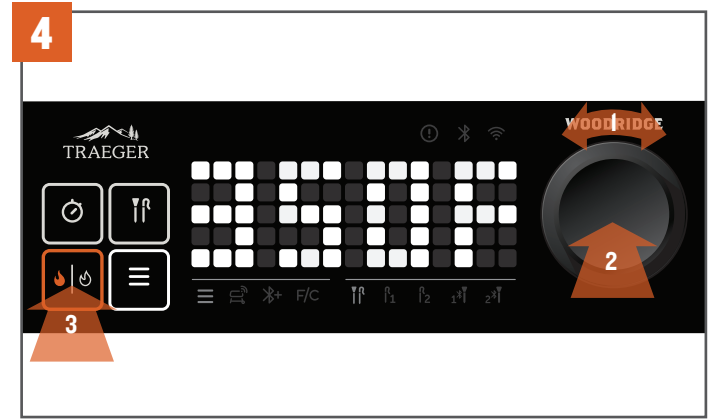

Turn the selection dial to set the grill's temperature to 350°F, then press the dial. Press the ignite/shutdown button.

PRO TIP: This seasoning process is important to ensure proper grill performance. Make sure that all internal components have been properly installed prior to this seasoning cycle and that there is no food on the grill grates during this process.



The grill temperature will display as it increases to the set temperature.

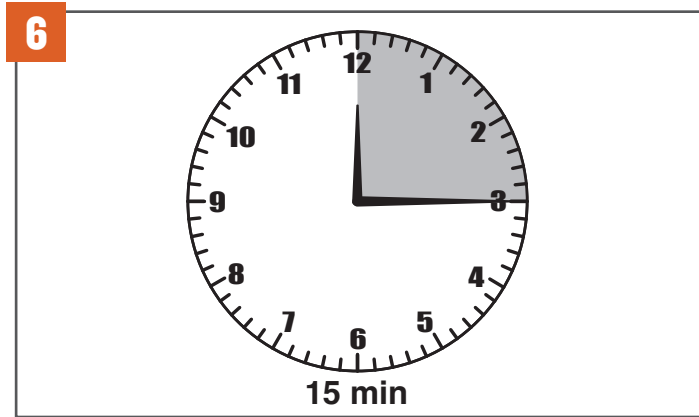

Once the grill has reached 350°F, let it run for 15 minutes. While the grill is seasoning, you may see dark or excessive smoke and ash; this is normal and will be less on future startups.

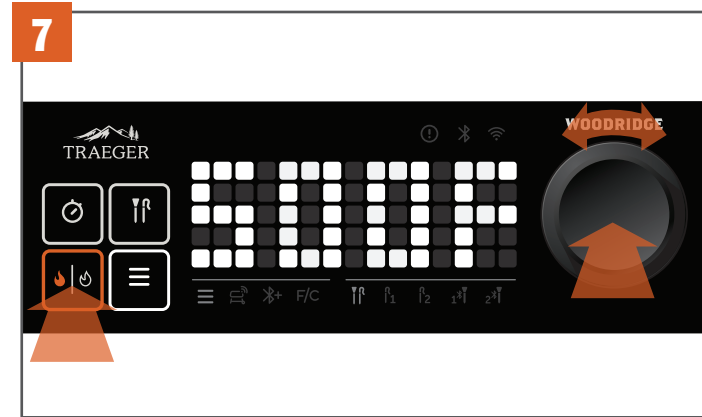

After 15 minutes at 350°F, increase the temperature to 500°F.

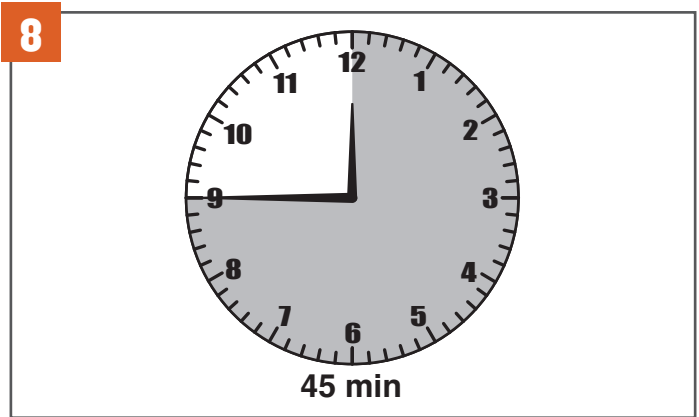

Once the grill has reached 500°F, let it run for another 45 minutes to ensure seasoning is completed properly.

NOTE: Getting to first-time seasoning temperature may take up to an hour.



SEASONING YOUR GRILL CONTINUED

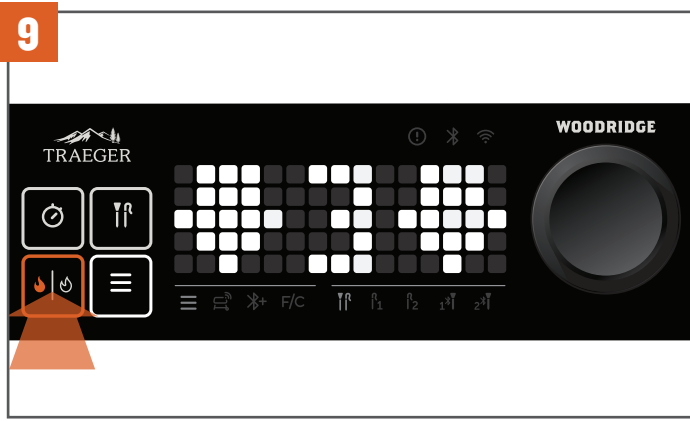

After 45 minutes at 500°F, shut down the grill and let the shutdown cycle complete. To shut down your grill, press and hold the ignite/shutdown button or the selection dial for three seconds until the display shows the shutdown animation.

NOTE: Always initiate a shutdown cycle after each and every cook.



A countdown timer begins while the grill is shutting down. You will hear the fan continue to run.

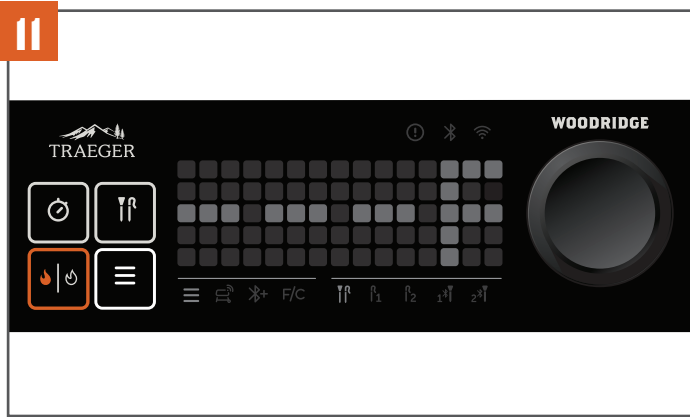

Once this countdown is complete, the shutdown cycle is complete.

NOTE: It is normal to observe ash on the drip tray and/or grill grates after seasoning. Simply wipe away ash on grill grates prior to your first cook.

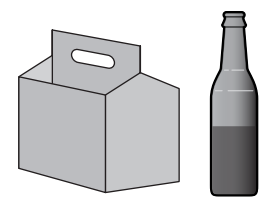



NOTES



