

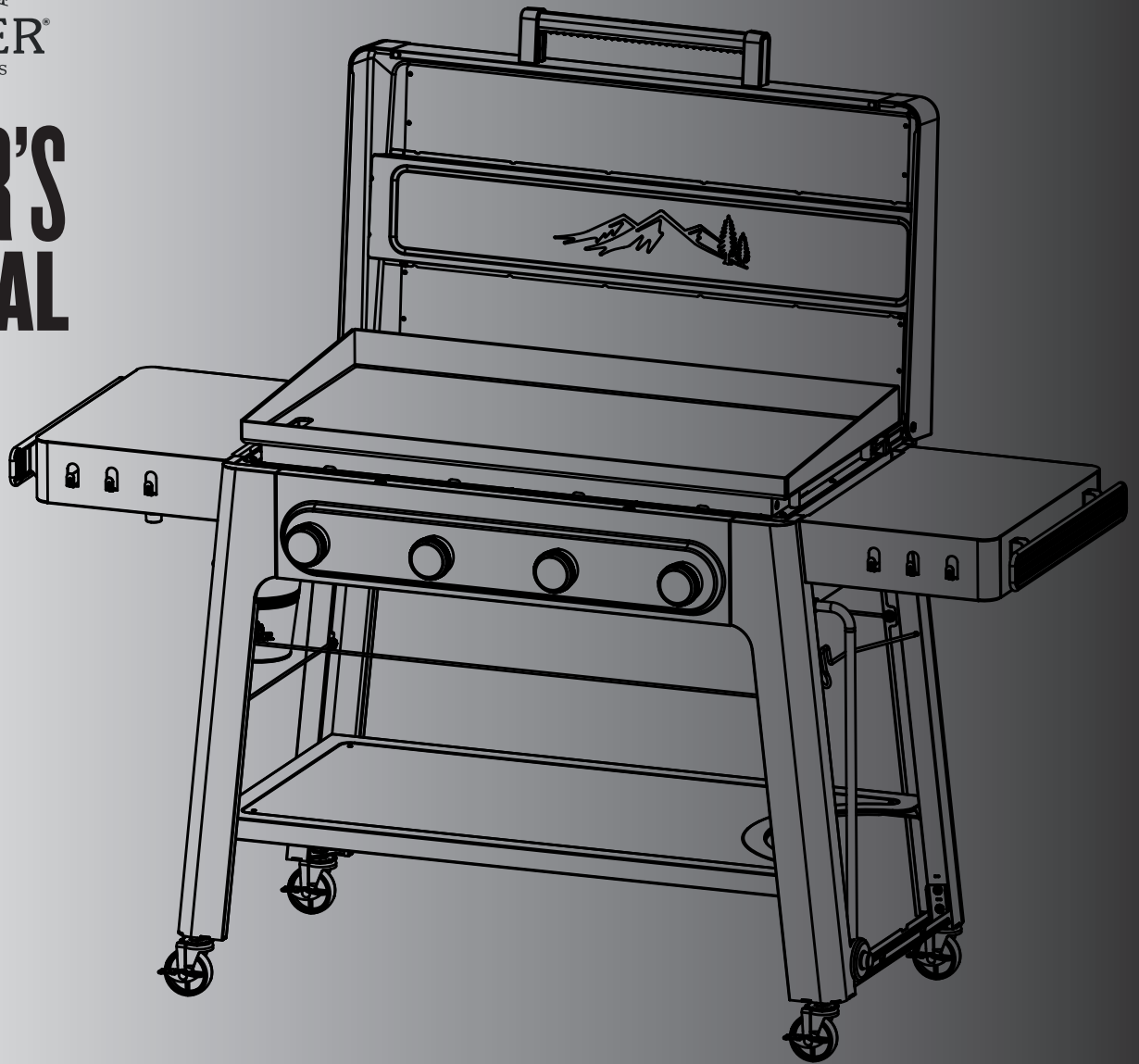

OWNER'S MANUAL



IRONTOP™ 2-BURNER AND 4-BURNER GRILLS

MODELS TF2NN50DNU IRONTOP™ 2 and TF4NN64DNU IRONTOP™ 4

Griddle top is made
of steel containing
approximately
52% iron.

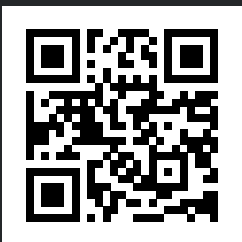

Scan here to access this manual in different languages, as well as to learn how to set up, season, and get the most out of your IronTop™ Grill.

T19602B

IMPORTANT SAFETY PRECAUTIONS

READ ALL INSTRUCTIONS BEFORE INSTALLING AND USING YOUR TRAEGER® IRONTOP™ GRILL

SAFETY ALERT KEY

- ⚠ DANGER** Indicates an imminently hazardous situation which, if not avoided, may result in death or serious injury.
- ⚠ WARNING** Indicates the possibility of serious bodily injury if the instructions are not followed.
- ⚠ CAUTION** Indicates a potentially hazardous situation which, if not avoided, may result in minor or moderate injury.

A MAJOR CAUSE OF FIRES IS FAILURE TO MAINTAIN REQUIRED CLEARANCES (AIR SPACES) BETWEEN COMBUSTIBLE MATERIALS AND YOUR IRONTOP™ GRILL. IT IS OF UTMOST IMPORTANCE THAT THIS PRODUCT BE INSTALLED ONLY IN ACCORDANCE WITH THESE INSTRUCTIONS.

When properly operated and maintained, cooking with a Traeger® IronTop™ Grill brings years of enjoyment to you and your friends and family. Your new Traeger® IronTop™ Grill is specially designed to make cooking easier while giving you optimal performance to create the most flavorful food.

Please read this entire manual before installation and operation. Anyone who uses this IronTop™ Grill should also read the entire manual before operating it. Failure to follow these instructions could result in property damage, bodily injury, or even death. Contact local building or fire officials about restrictions and installation inspection requirements in your area. **Save these instructions.** If you are assembling this unit for someone else, provide this manual for the owner to read and save for future reference.

⚠ DANGER

If you smell gas:

- Shut off gas to the appliance.
- Extinguish any open flame.
- Open lid.
- If odor continues, keep away from the appliance and immediately call your gas supplier or your fire department.

⚠ WARNING

- Do not store or use gasoline or other flammable liquids or vapors in the vicinity of this or any other appliance.
- An LP tank not connected for use shall not be stored in the vicinity of this or any other appliance.

⚠ WARNING Fire Hazard

- When operating your Traeger® IronTop™ Grill, maintain the **MINIMUM** distances shown below from the IronTop™ Grill to any nearby combustibles, including wooden railings, home siding, window frames, furniture, trees, and trash receptacles, etc.

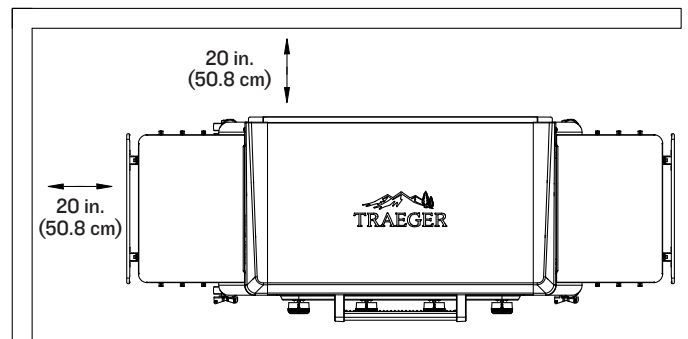

- **Do Not** install or operate the IronTop™ Grill indoors, in or on recreational vehicles or boats, or under a combustible ceiling or overhang.
- **Do Not** install or operate your Traeger® IronTop™ Grill on combustible floors or surfaces.
- **Do Not** store or use a spare LP tank, gasoline, or other flammable vapors, liquids, or materials in, under, or in the vicinity of the IronTop™ Grill.
- Always remove cooking tools and ingredients while the IronTop™ Grill is unattended to reduce the risk of fire.
- **Never** fill an LP (liquid propane) tank beyond 80% full. An overfilled or improperly stored tank is a hazard due to possible gas release from the safety relief valve.
- **Never** leave an LP tank inside a vehicle; it may become overheated by the sun.

- **Do Not** obstruct the flow of combustion and ventilation air of the IronTop™ Grill, cover slots, holes, or passages in the IronTop™ Grill, or cover the IronTop™ Grill cooktop with material such as aluminum foil. Doing so blocks airflow through the IronTop™ Grill and may cause carbon monoxide poisoning. Aluminum foil linings may trap heat, causing a fire hazard.
- Clean your IronTop™ Grill and replace the grease bucket liner regularly. Always wait until the IronTop™ Grill has completely cooled before removing the grease bucket.

⚠ WARNING Fire Hazard

- If the IronTop™ Grill does not ignite within 5 seconds, turn burner controls OFF (O), wait 5 minutes to allow gas to dissipate, and repeat ignition procedure. If IronTop™ Grill does not ignite, gas will continue to flow out of burner and could accidentally ignite.
- Inspect the hose of the IronTop™ Grill's LP tank before each use. If there is evidence of abrasion, wear, cuts, or leaks, the hose must be replaced prior to operation.
- If grease or other hot material drips from the IronTop™ Grill onto valve, hose or regulator, turn off gas supply immediately. Determine the cause and correct, clean and inspect valve, hose and regulator. Before continuing, perform a leak test.
- **Never** use an LP tank that is visibly rusted, damaged, or out of date.

⚠ WARNING Burn Hazard

- **Do not** close the lid when preheating or operating the grill, as lid and handle will become very hot. Only close lid to protect grill surface when grill is turned off and is cool to the touch.
- The IronTop™ Grill cooktop and surrounding areas are extremely hot during and after operation. Use caution when loading food onto the cooktop and when inserting, removing, or adjusting your meat probes.
- **Do Not** touch the cooktop, the lip around the cooktop, or the faceplate during or immediately after operation. Always use heat protection when operating the IronTop™ Grill.
- **Never** move the IronTop™ Grill when it is operating or hot. Let the IronTop™ Grill cool thoroughly and close the IronTop™ Grill lid before moving or attempting to transport. If you are transporting your IronTop™ Grill in a vehicle after cooking on it, make sure the flame is completely out, the gas is turned off, and the IronTop™ Grill is cold before placing it in any vehicle.
- **Never** leave the IronTop™ Grill unattended when young children or pets are present.
- Grill handles and knobs may become hot to the touch or exceed safe touch temperatures when operated under extreme conditions including, but not limited to, prolonged exposure to direct sunlight, high ambient temperatures, or in the event of a grease fire. **ALWAYS** use heat protection when operating

or handling your grill under these conditions.

⚠ WARNING Product Hazard

- **Never** modify the IronTop™ Grill or install any parts or components not authorized by Traeger for use with this product. Any modification of this IronTop™ Grill or installation of unauthorized parts or components will void the warranty and may create a safety hazard including, without limitation, a fire.
- Make sure the IronTop™ Grill is leveled.
- **Never** move the IronTop™ Grill with the lid open. Always close the IronTop™ Grill lid prior to moving.
- **Never** move the IronTop™ Grill with the LP tank connected and on the base. Always disconnect the LP tank and remove from the base prior to moving.
- **NEVER** add cold or frozen food or liquids to a hot IronTop™ Grill. Doing so may cause the IronTop™ Grill to warp.
- Appliance installation must conform with local codes, or in the absence of local codes, with either the National Fuel Gas Code, ANSI Z223.1/NFPA 54, ANSI/NFPA 58, Natural Gas and Propane Installation Code, CSA B149.1, or Propane Storage and Handling Code, B149.2, or the Standard for Recreational Vehicles, ANSI A 119.2/NFPA 1192, and CSA Z240 RV Series, Recreational Vehicle Code, as applicable.
- Fuels used in liquid propane gas appliances, and the products of combustion of such fuels, can expose you to chemicals, including benzene, which is known to the State of California to cause cancer and cause birth defects or other reproductive harm.
- If the IronTop™ Grill is not in use, the gas must be turned off at the LP tank.
- The IronTop™ Grill can be stored indoors only if the tank is disconnected and removed from the grill.
- The LP tank must be stored outdoors out of the reach of children and should not be stored in a building, garage, or any other enclosed area. An appliance is considered to be outdoors if **1)** installed with shelter no more inclusive than with walls on three sides, but with no overhead cover; **2)** within a partial enclosure that includes an overhead cover and no more than two sidewalls (sidewalls may be parallel, as in a breezeway, or at right angles to each other); or **3)** within a partial enclosure that includes an overhead cover and three sidewalls, as long as 30% or more of the horizontal periphery of the enclosure is permanently open. All openings must be permanently open; sliding doors, garage doors, windows, or screened openings are not considered as permanent openings.
- Place a dust cap on the tank valve outlet whenever the tank is not in use. Only install on the tank valve outlet the type of dust cap that is provided with the tank valve. Other types of caps or plugs can result in propane leaking.

SAVE THESE INSTRUCTIONS



**WELCOME
TO THE
TRAEGERHOOD™**

TABLE OF CONTENTS

2 IMPORTANT SAFETY PRECAUTIONS

6 ASSEMBLING YOUR GRILL

31 GETTING TO KNOW YOUR IRONTOP™ GRILL

33 IRONTOP™ GRILL FEATURES

34 ONBOARDING 1: INSTALLING PROPANE TANK

37 ONBOARDING 2: SEASONING YOUR IRONTOP™ GRILL

39 USING YOUR IRONTOP™ GRILL

41 PRO TIPS FOR COOKING ON YOUR IRONTOP™ GRILL

42 WHEN COOKING IS COMPLETED

43 GREASE MANAGEMENT

43 SHUTTING DOWN YOUR IRONTOP™ GRILL

44 MAINTAINING YOUR IRONTOP™ GRILL

47 TROUBLESHOOTING

47 OPERATING TIPS

48 SERVICE

50 WARRANTY

ASSEMBLING YOUR GRILL

BEFORE YOU BUILD

SETUP SPACE



PRO TIP:
We recommend
assembling your grill
with two people.



PRO TIP: Build on the
bottom tray of the shipping
box to help prevent
scratches.

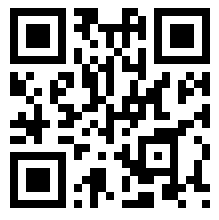

**SCAN FOR
STEP BY STEP
ANIMATED
INSTRUCTIONS**

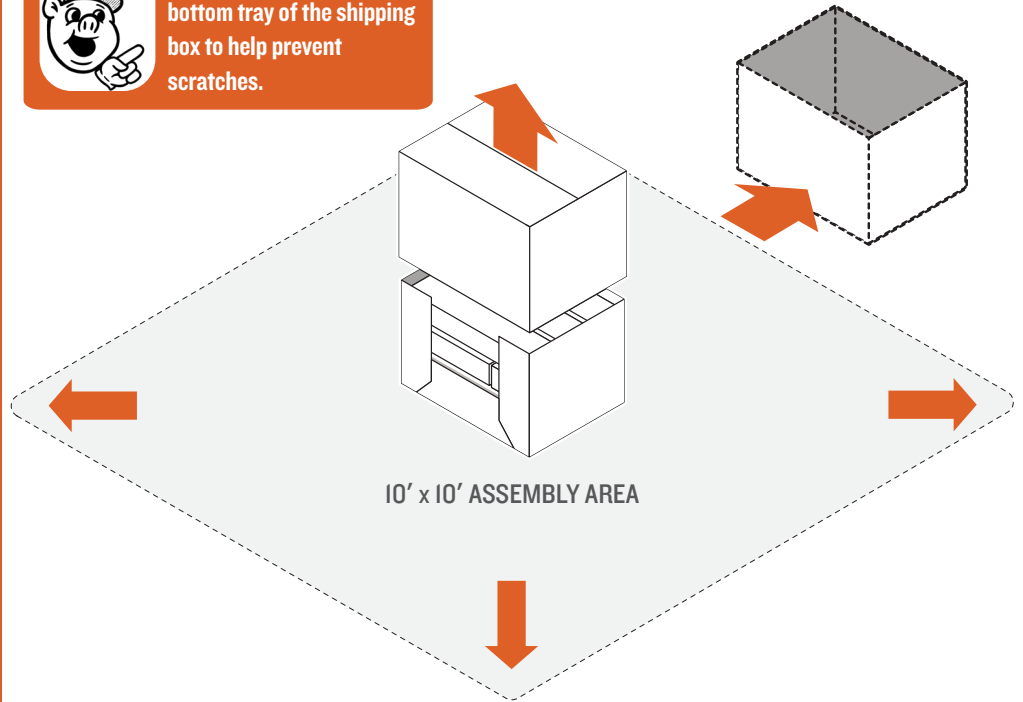

SETUP Once all components are unpacked, arrange pieces onto the bottom tray of the shipping box.

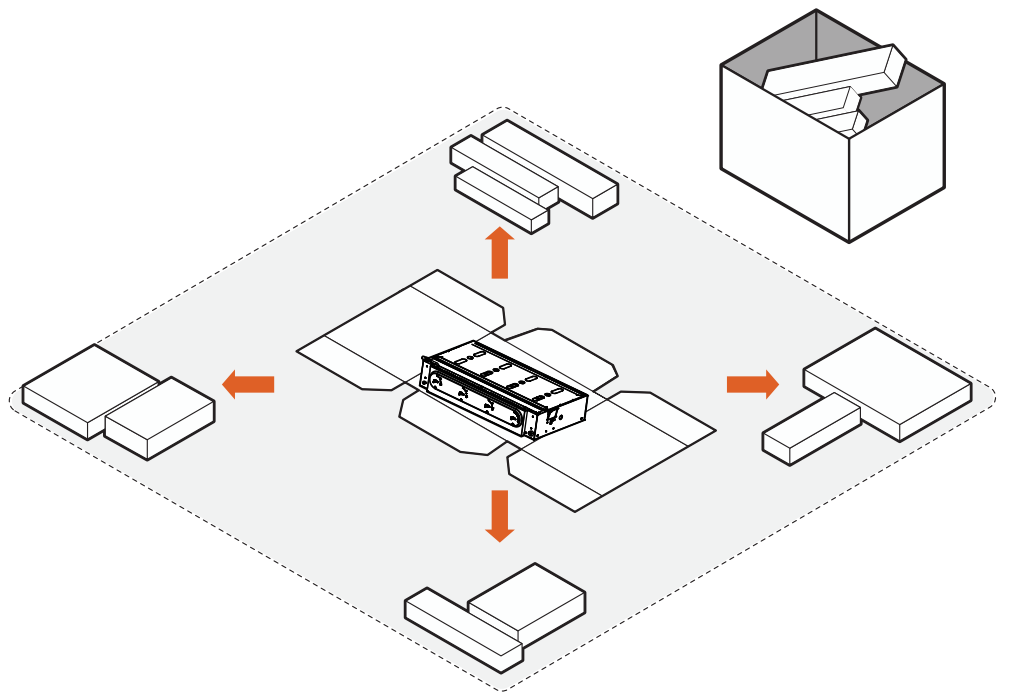

HARDWARE

(TOTAL QUANTITIES)

1:1 SCALE

x42 x2 extra

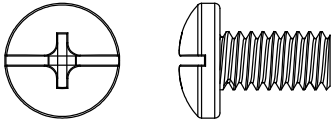

A #8x32

x18 x2 extra

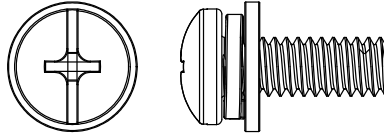

B 1/4 20
0.75 in.

x4 x1 extra

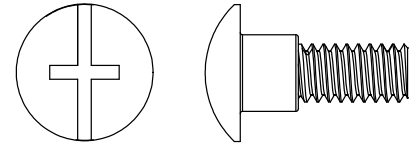

C 1/4 20
Shoulder Bolt

x7 (2-Burner model)

x8 (4-Burner model)

x1 extra

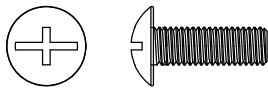

D Machine
Screw

x2

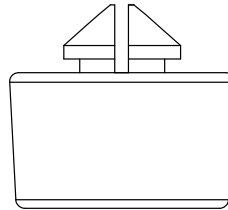

E Bumpers

x1

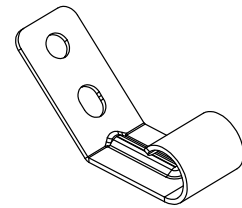

F Grease
Bucket Clip

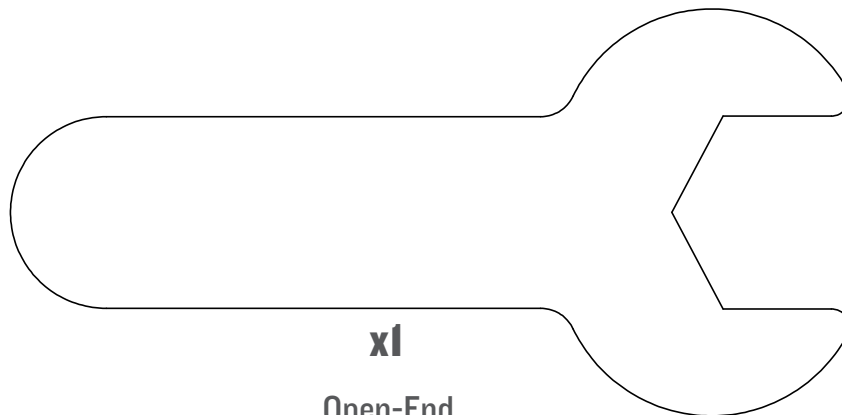

x1
Open-End
Wrench

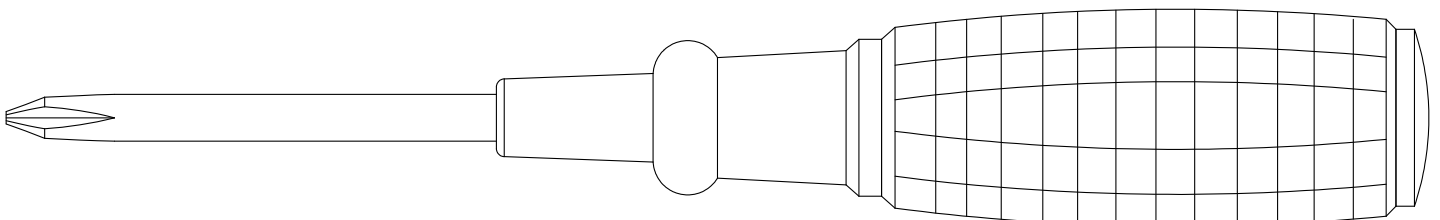

x1
Screwdriver



IMPORTANT:

Hand-tighten all screws first, then finish tightening with screwdriver after Step 2.

I ATTACH LEGS

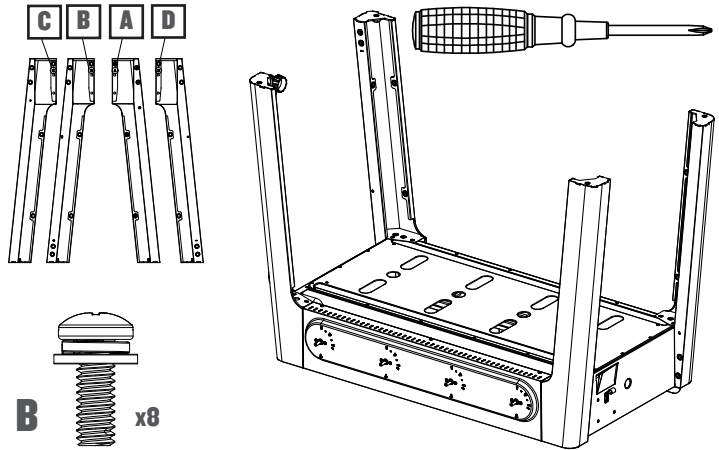

1A

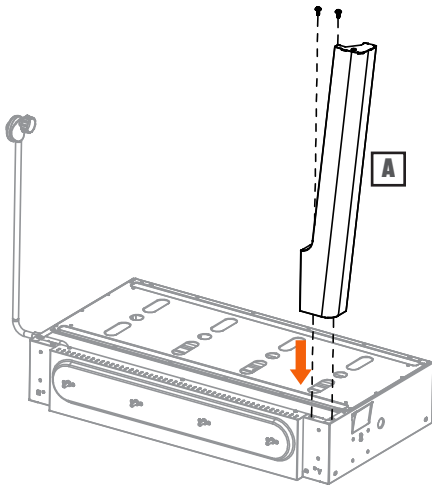

1C

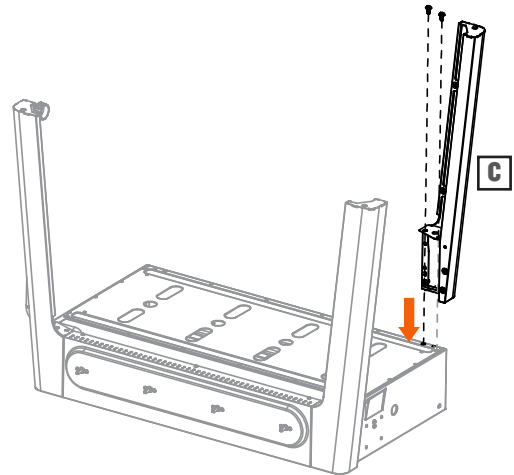

1B

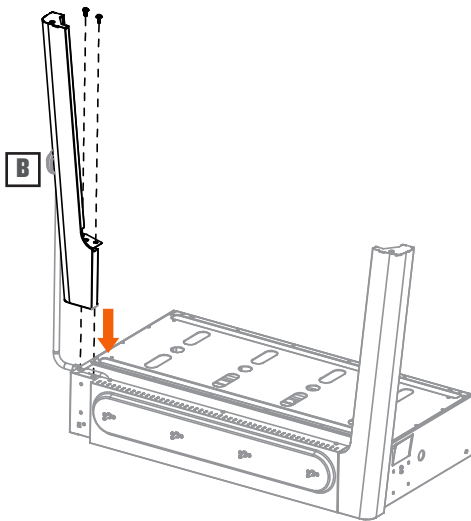

1D

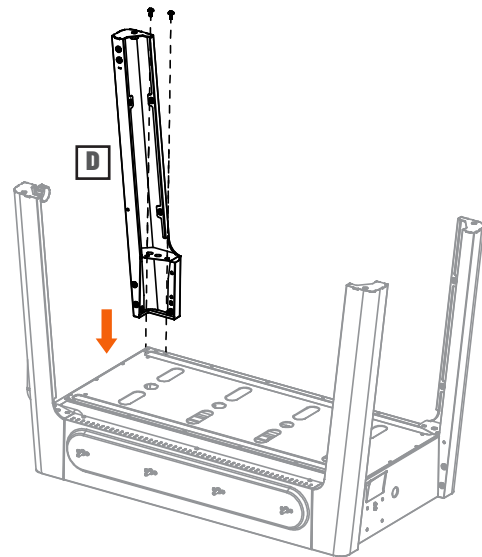



IMPORTANT:

Hand-tighten all screws first, then finish tightening them with screwdriver after shelf is installed.

2 ATTACH BOTTOM SHELF

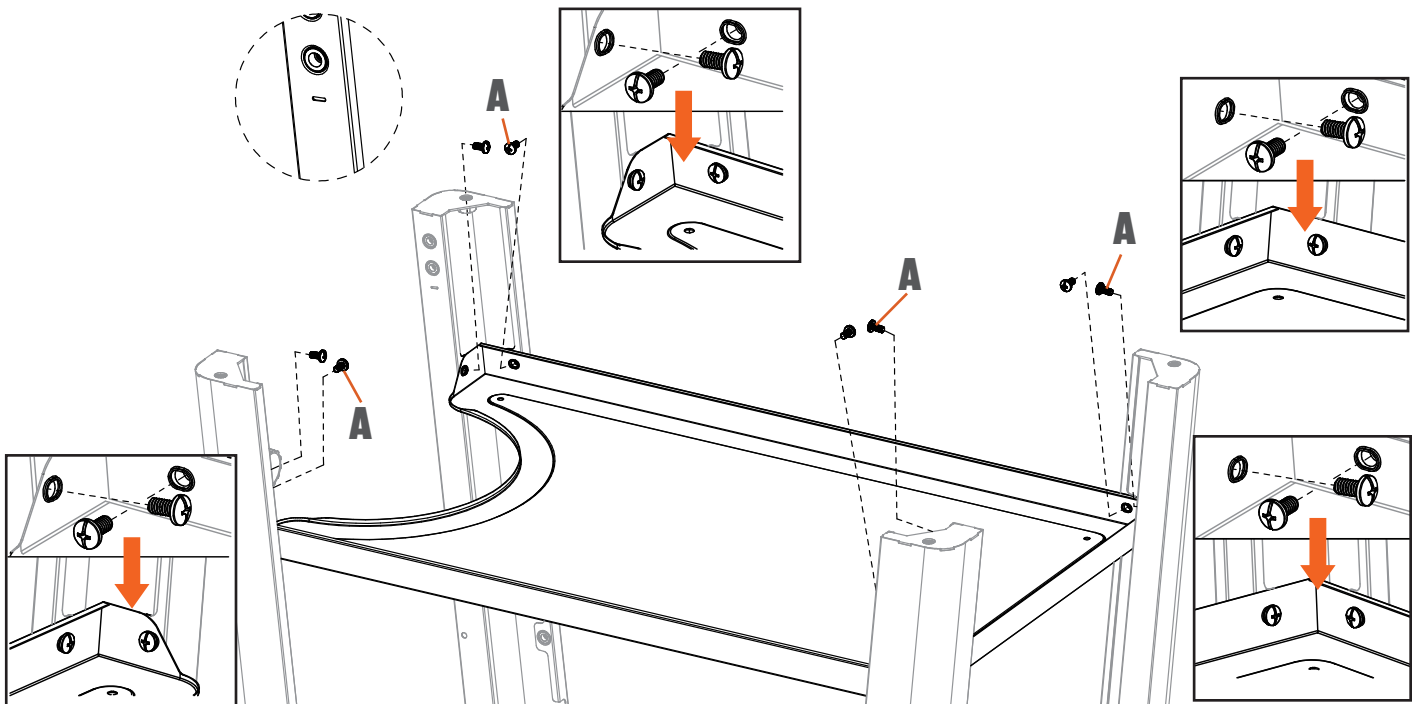
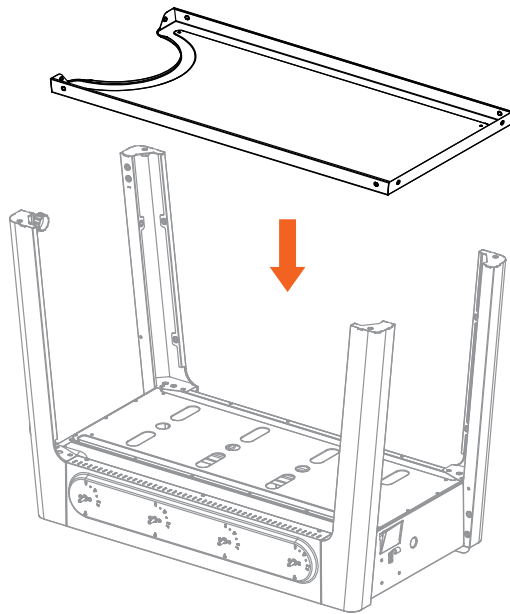
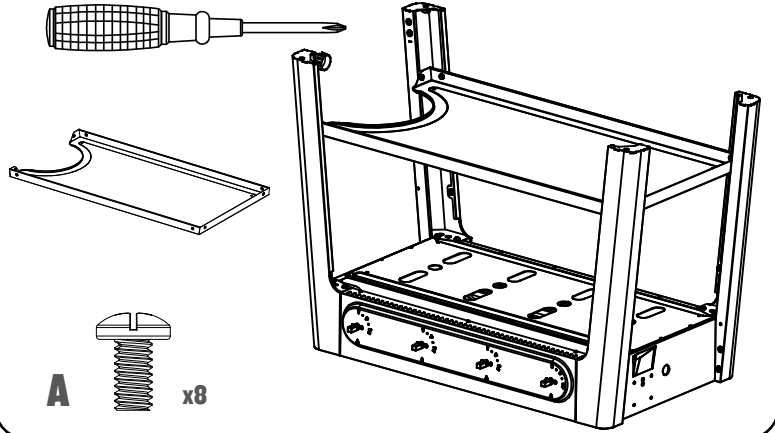

3 TIGHTEN ALL LEG SCREWS

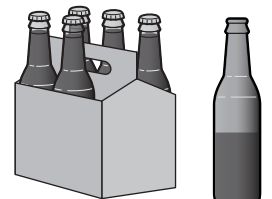
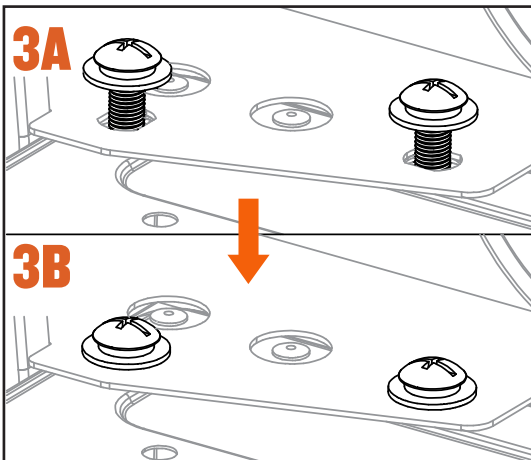
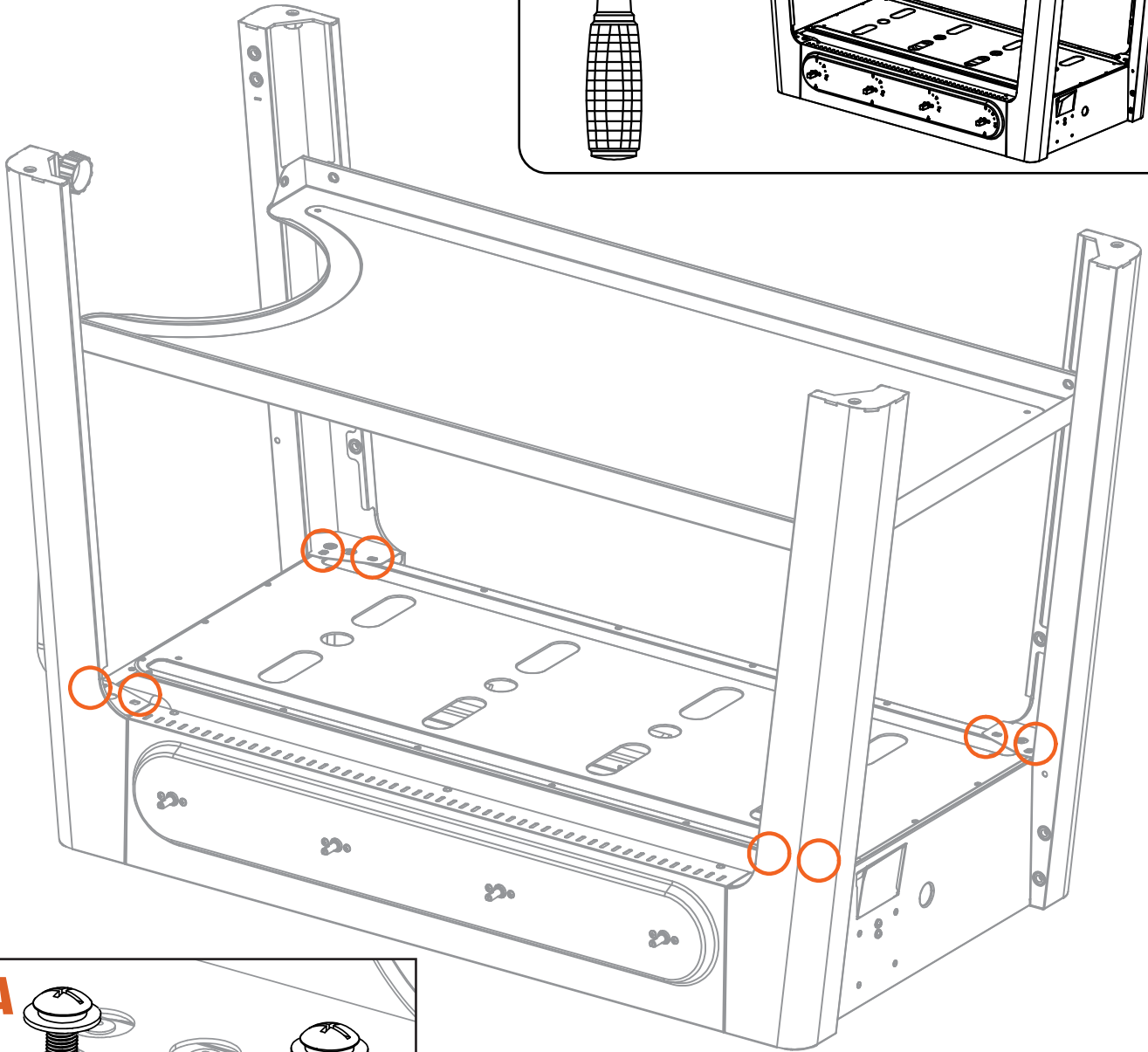
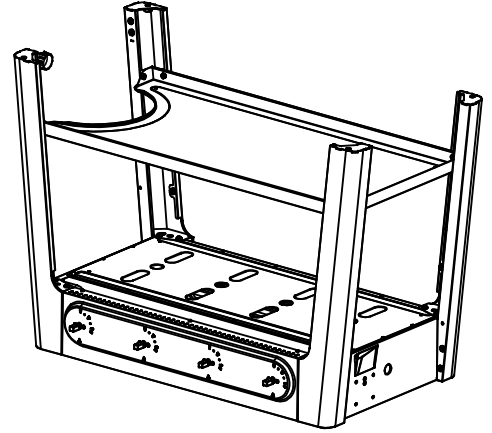
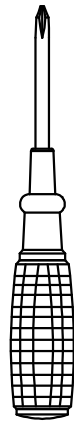



PRO TIP: The Stationary Side Shelf is the one with the product features sticker. The shelf with the ignition instructions is the Folding Side Shelf (installed later).

4 ASSEMBLE STATIONARY SIDE SHELF

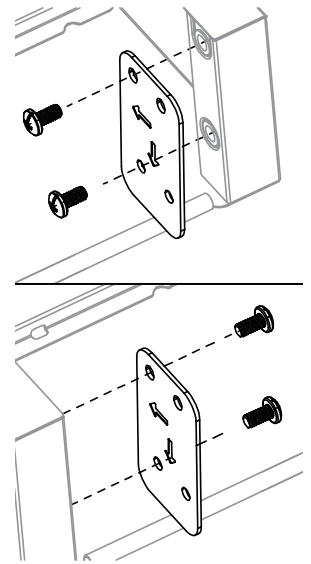
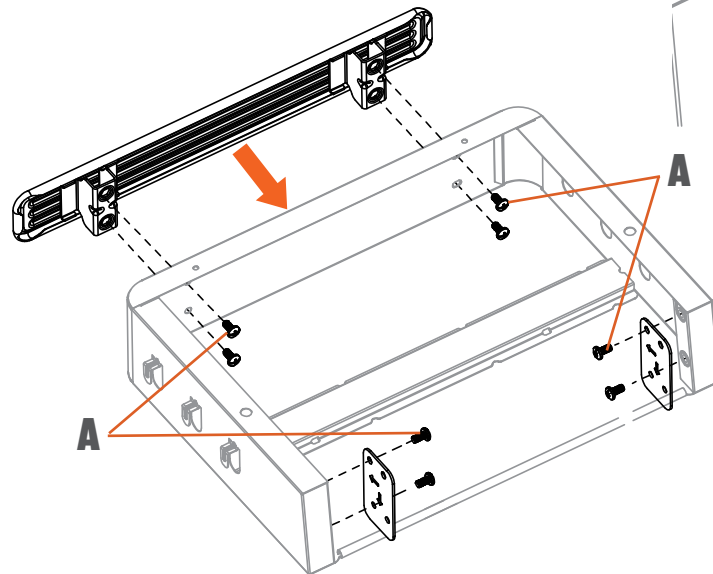
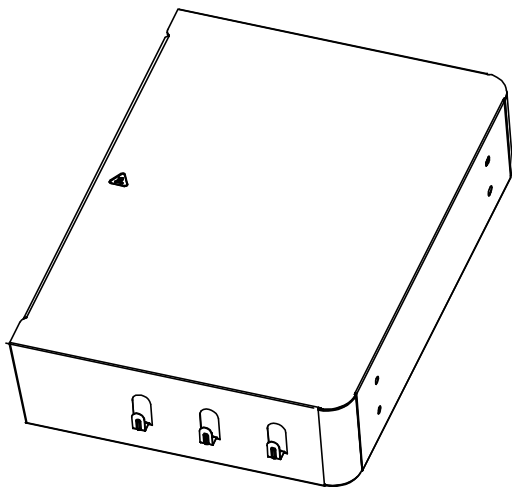
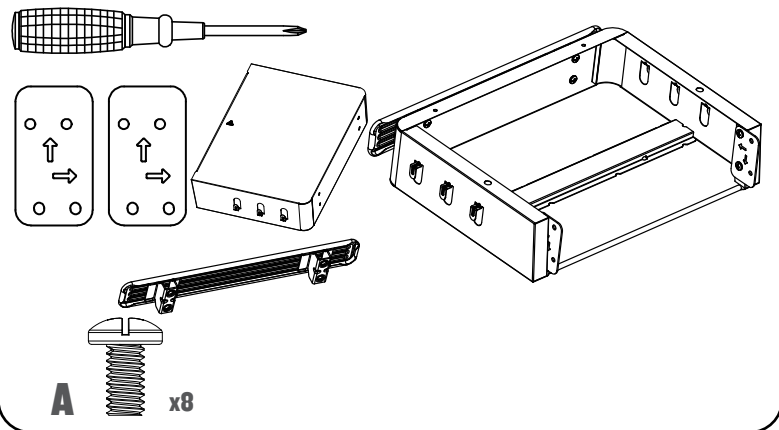

5 ATTACH STATIONARY SIDE SHELF

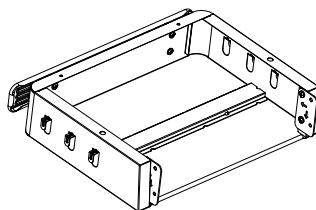
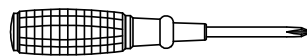

A x4

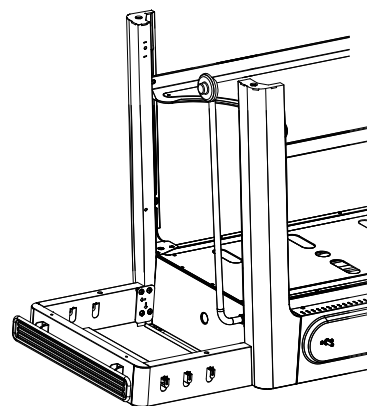

5A

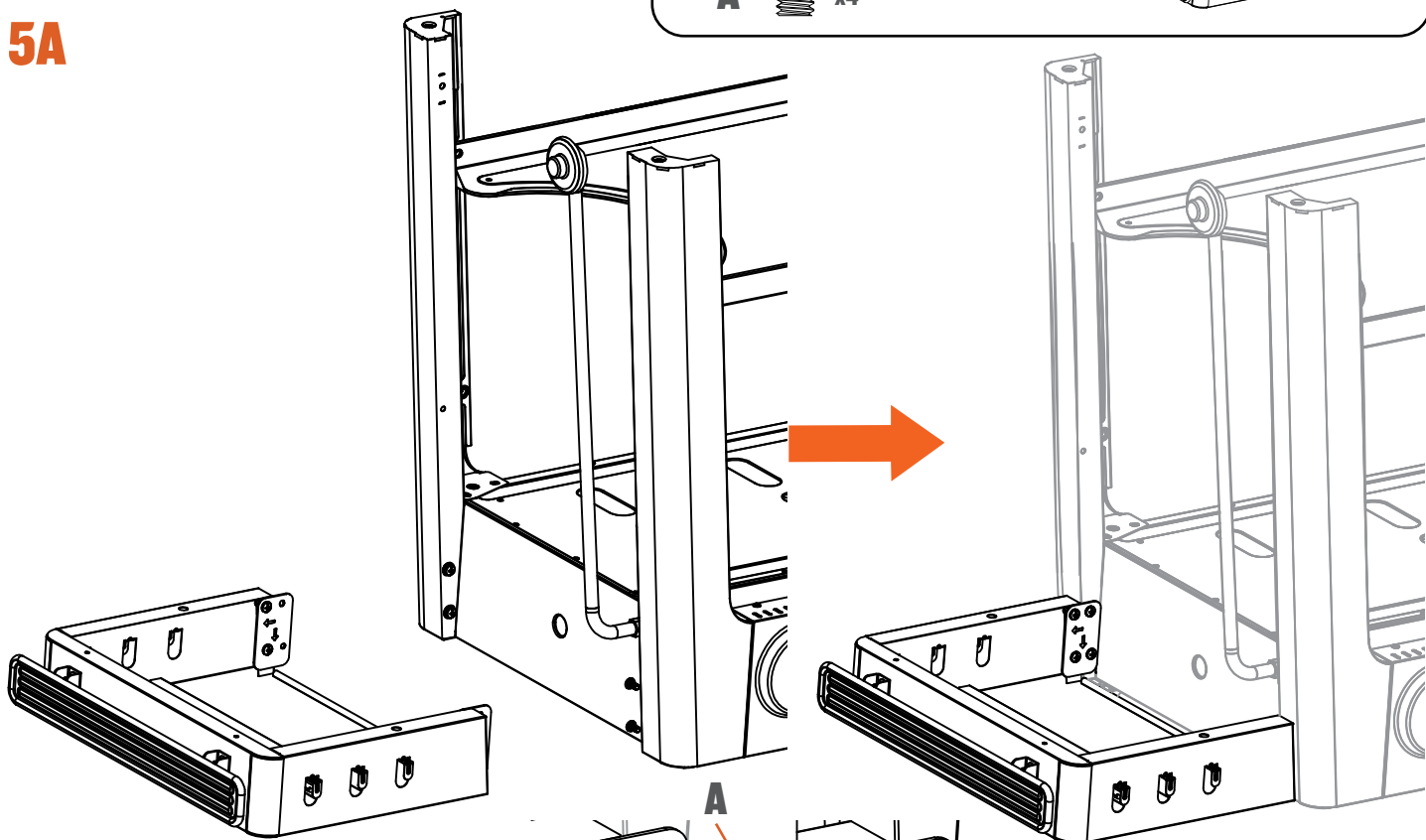

5B

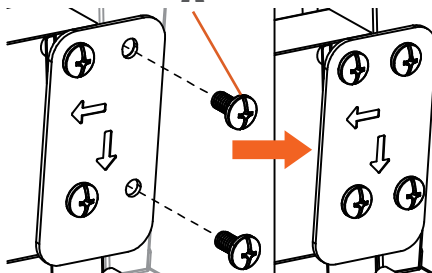
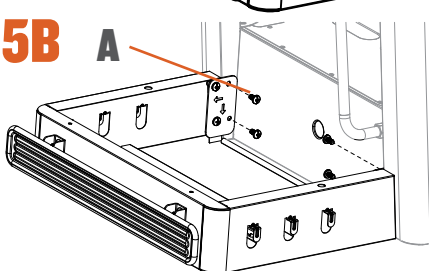

5C

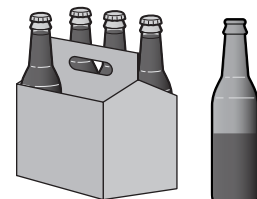
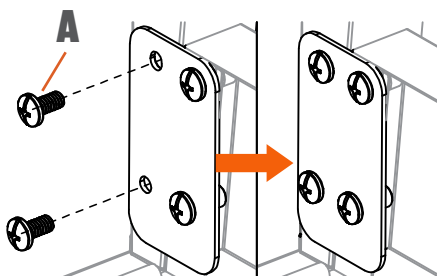
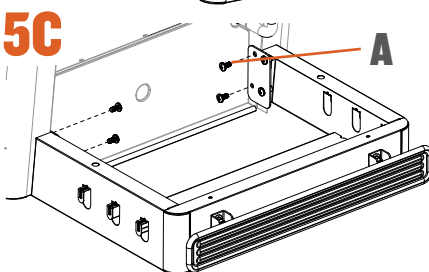

6 ATTACH GREASE BUCKET CLIP

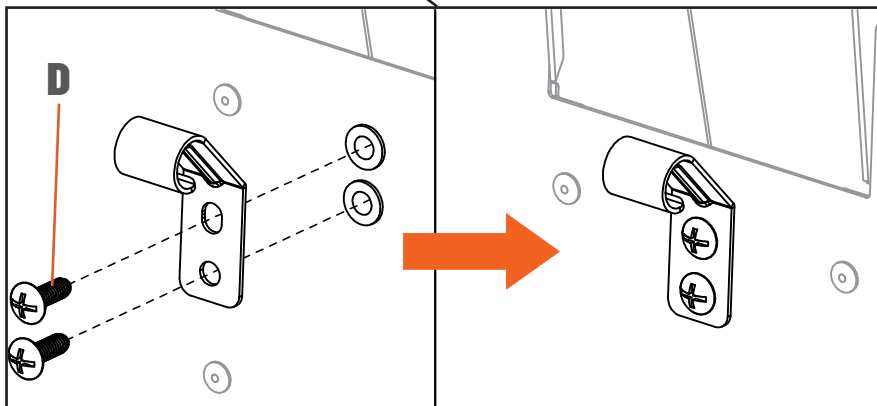
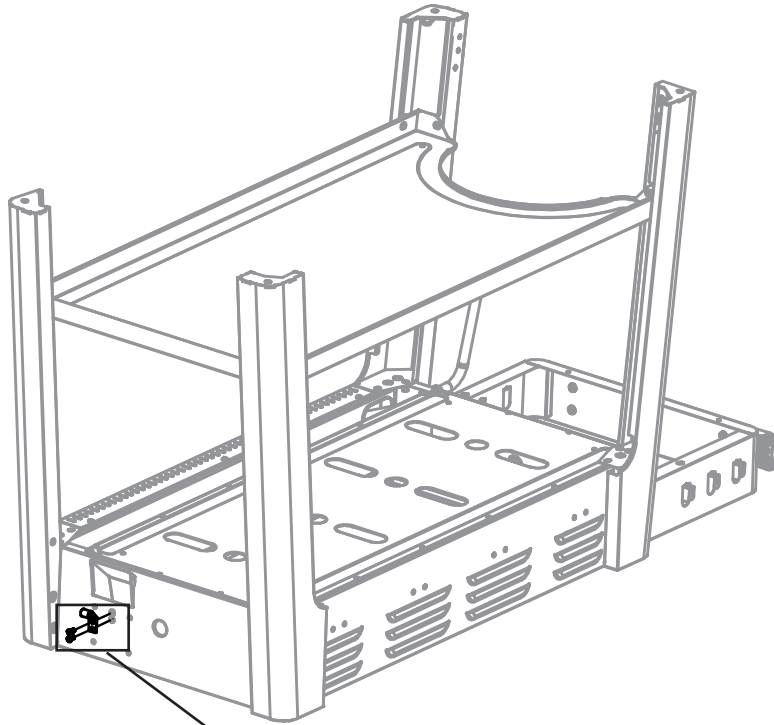
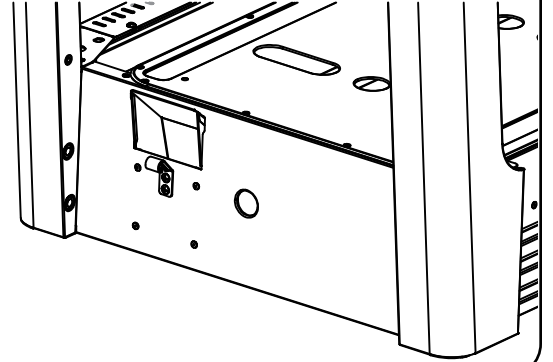
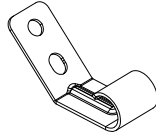
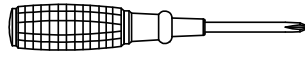



PRO TIP: Position the propane tank rest, aligning the + and - with the corresponding symbol on the legs.

7 ATTACH PROPANE TANK REST

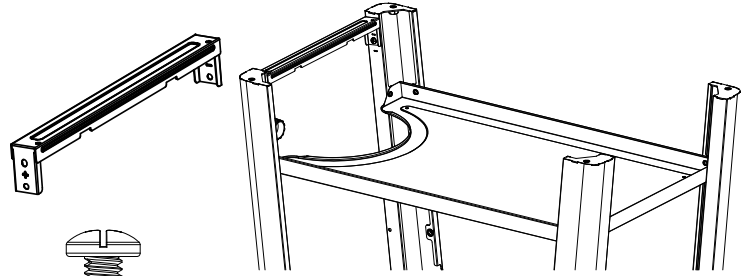
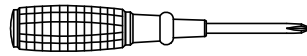

7A

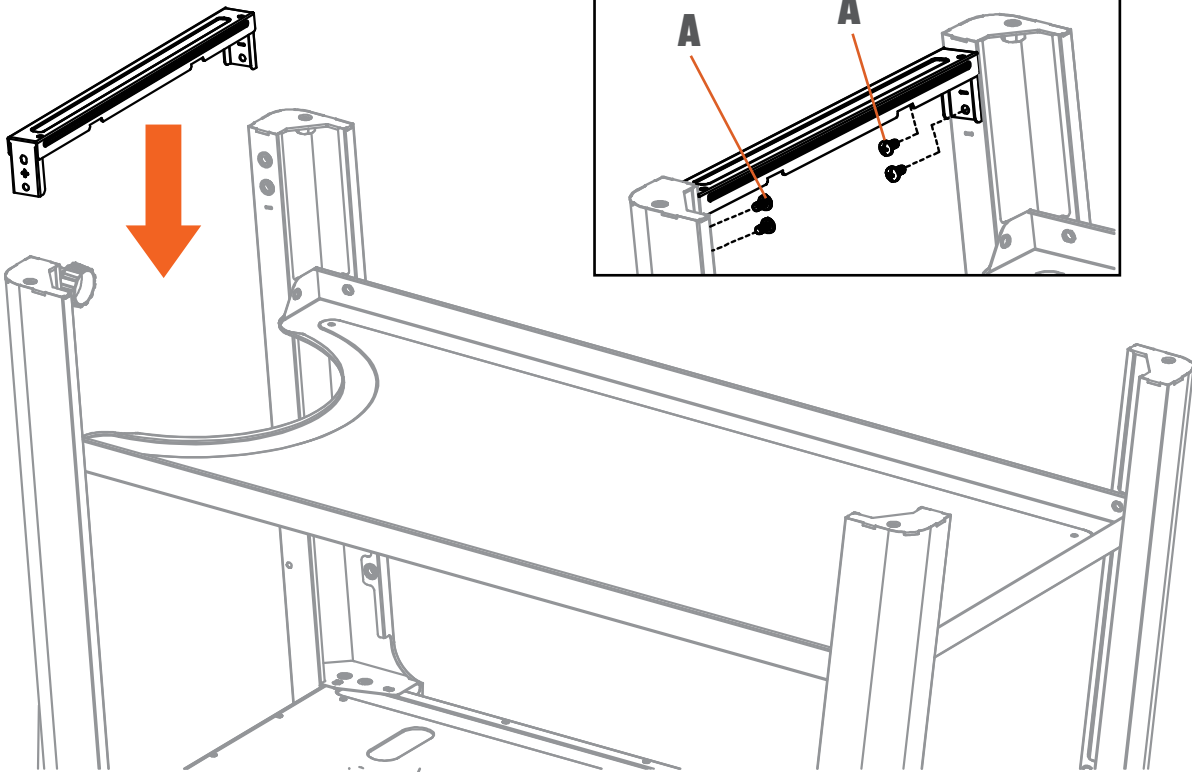

7B

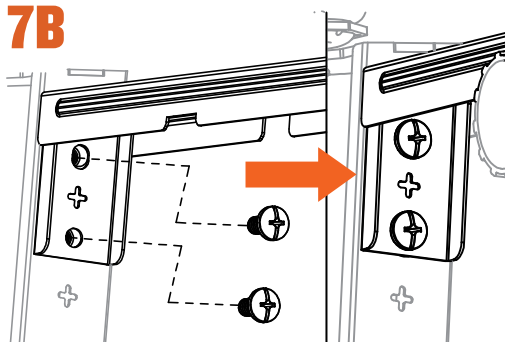

7C

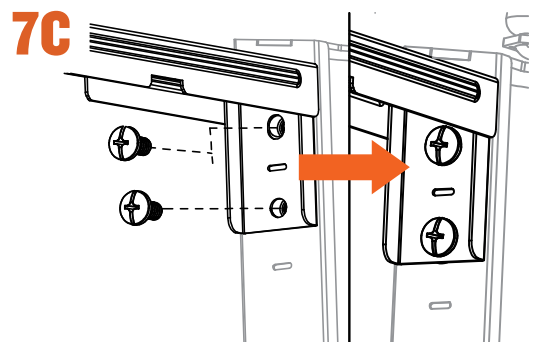

8 ATTACH CASTER WHEELS

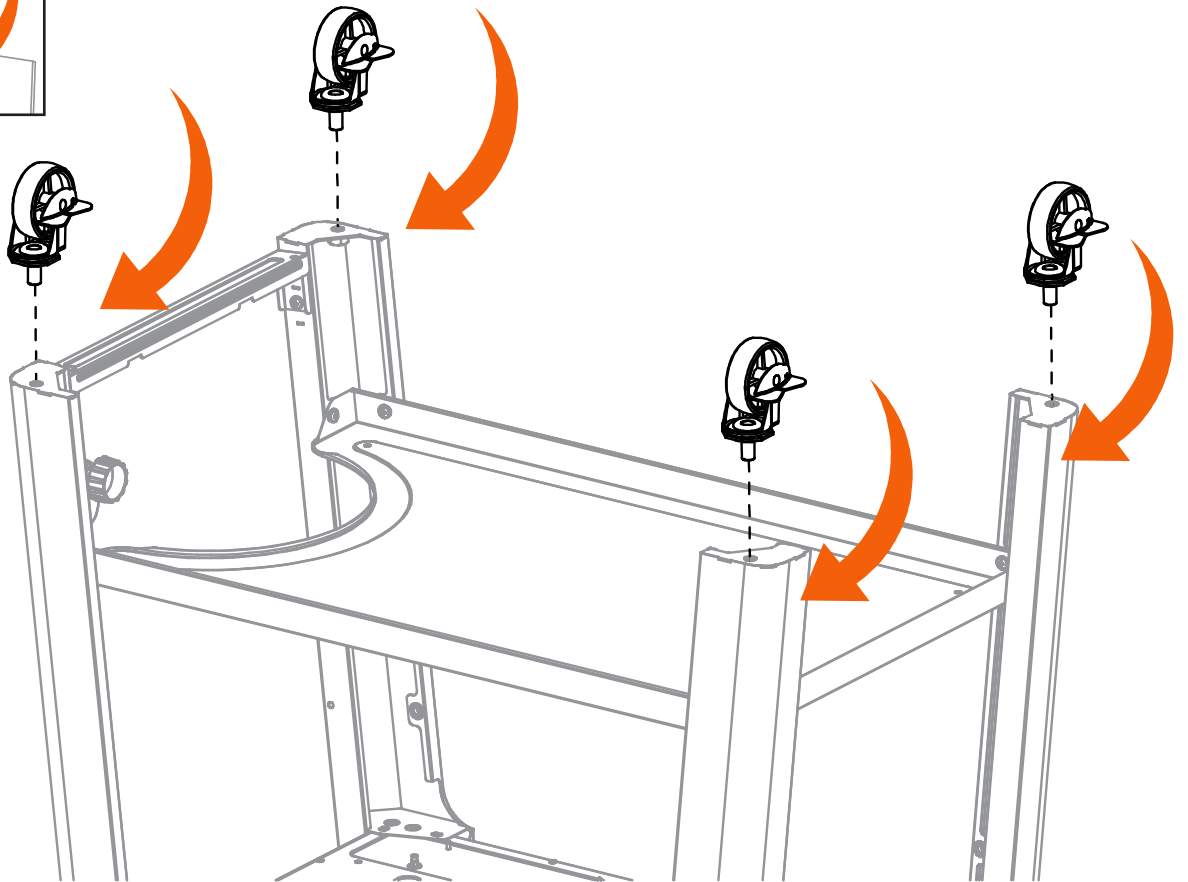
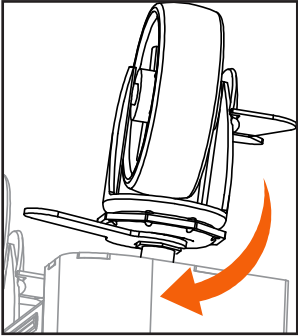
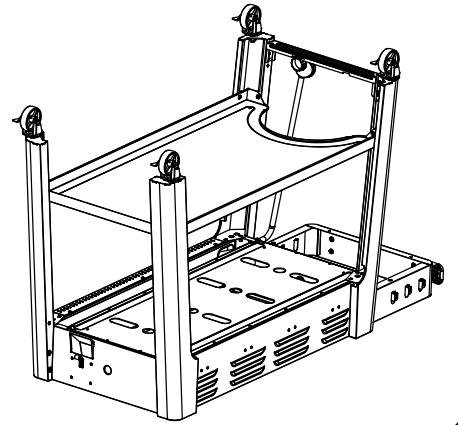
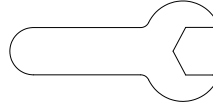
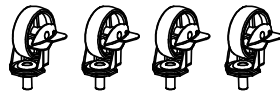



PRO TIP: Have a second person help stand the grill up.

9 STAND GRILL ON LEGS

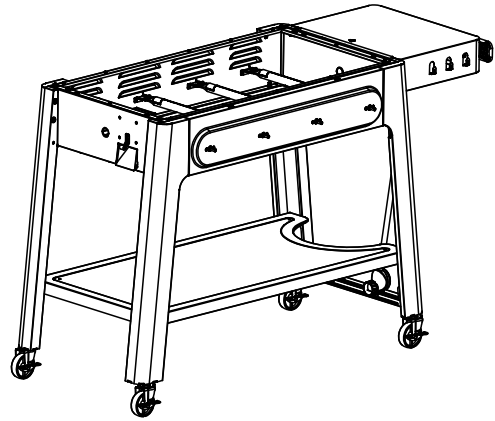

9A

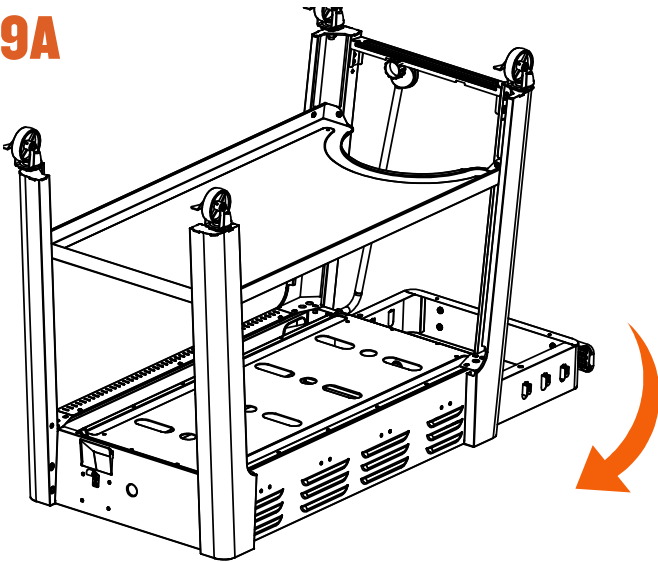

9C

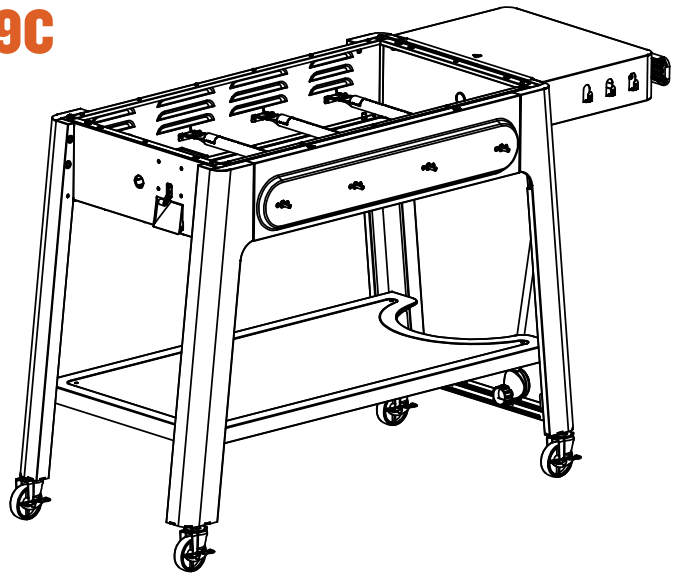

9B

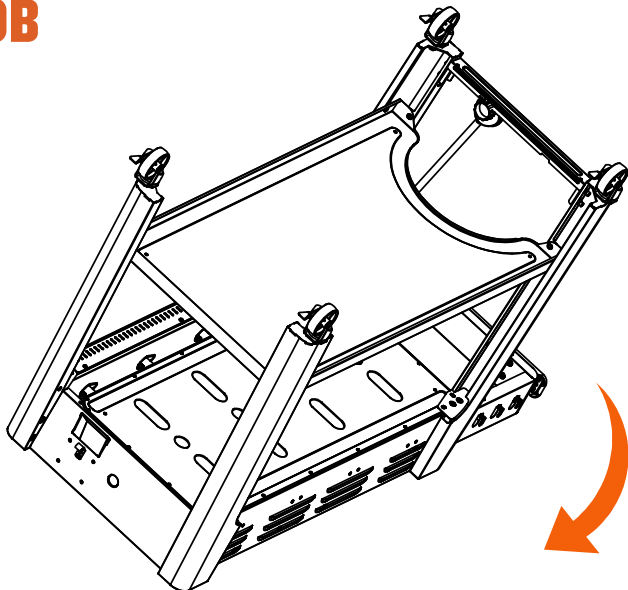

9D

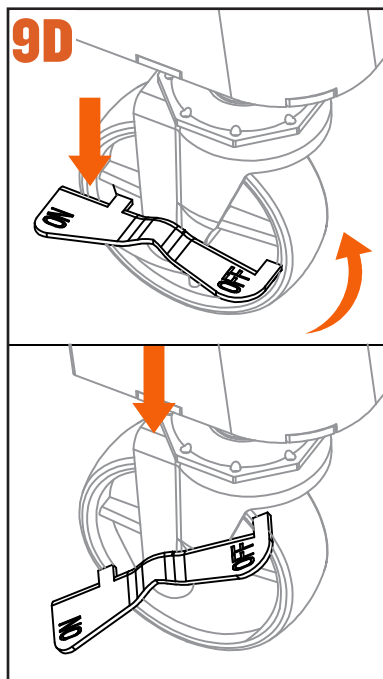

Press down on
ON to lock the
wheels.

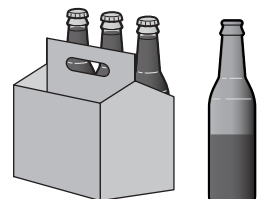

10 INSTALL TOP LEG SCREWS

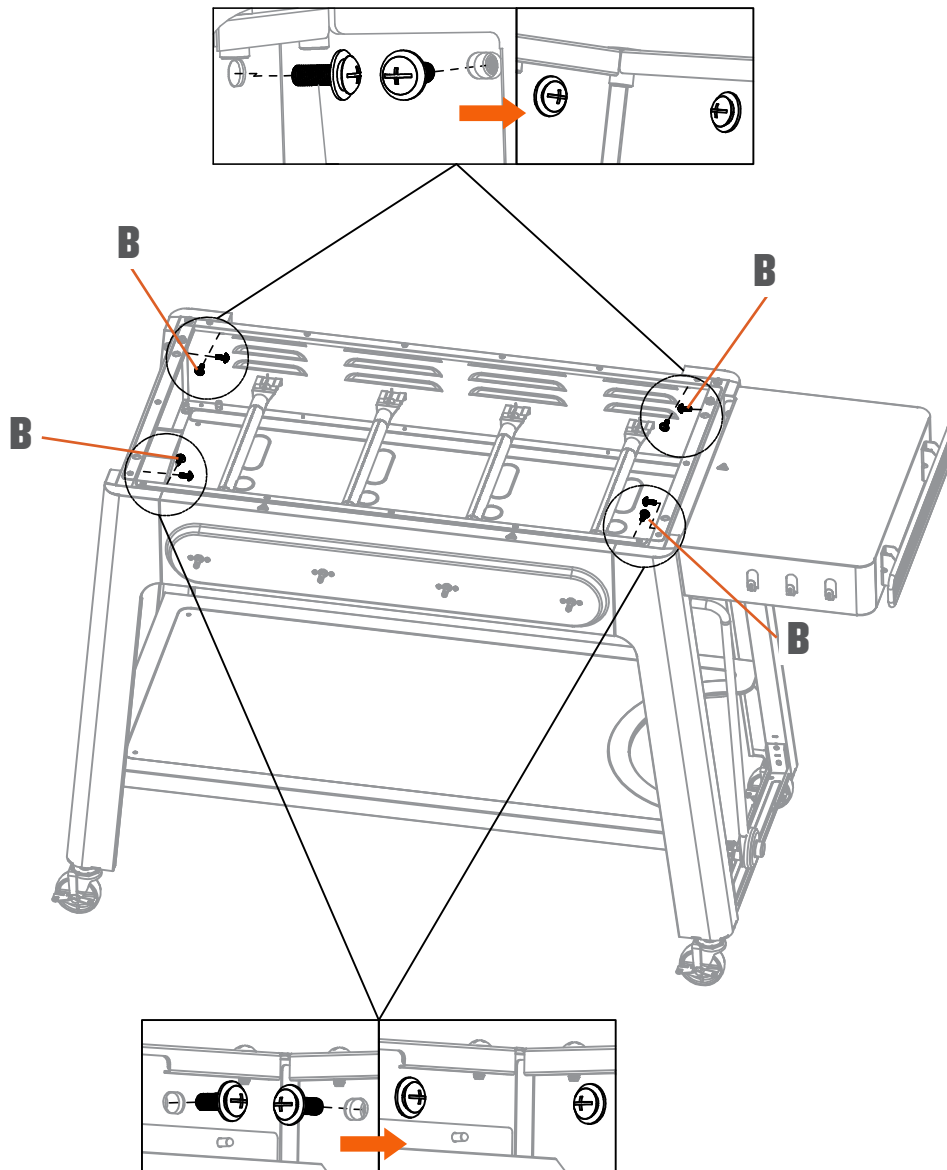
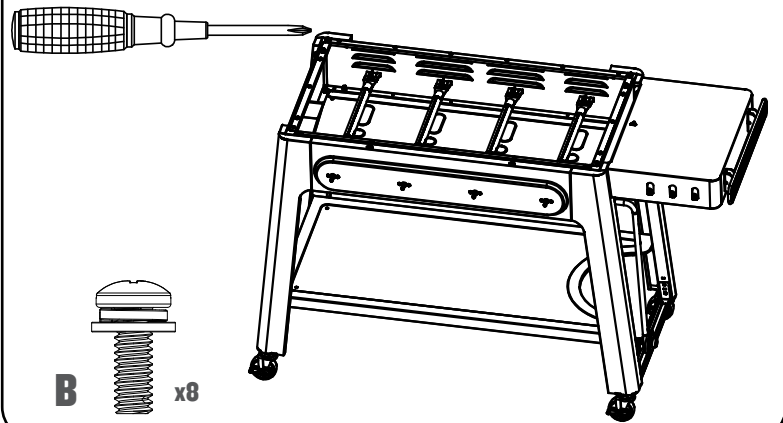

11 ATTACH P.A.L. RAIL TO FOLDING SIDE SHELF

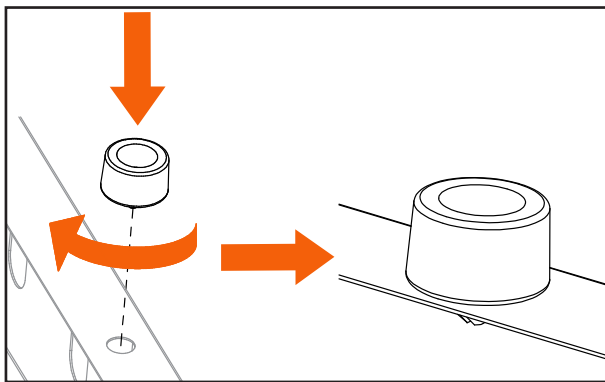
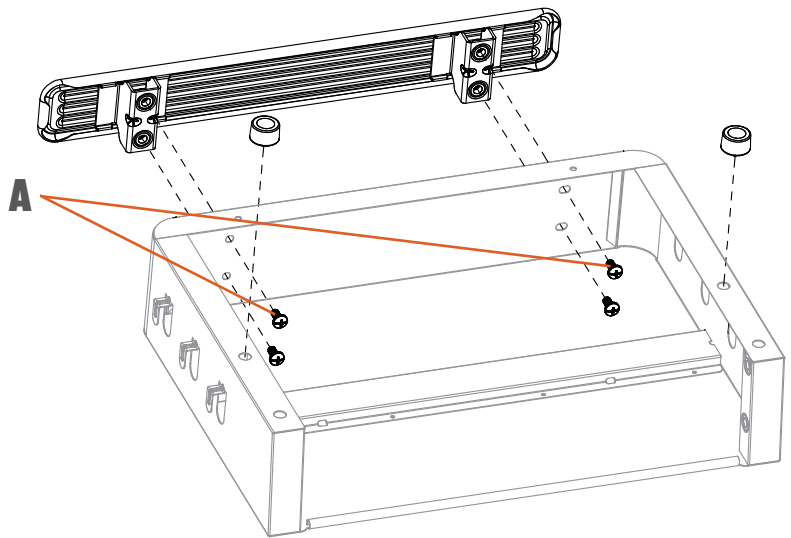
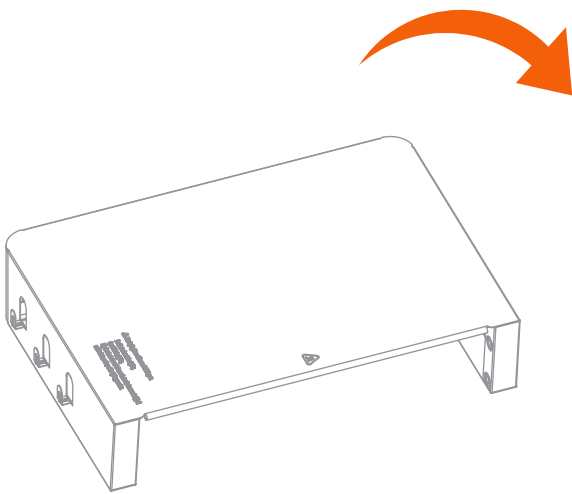
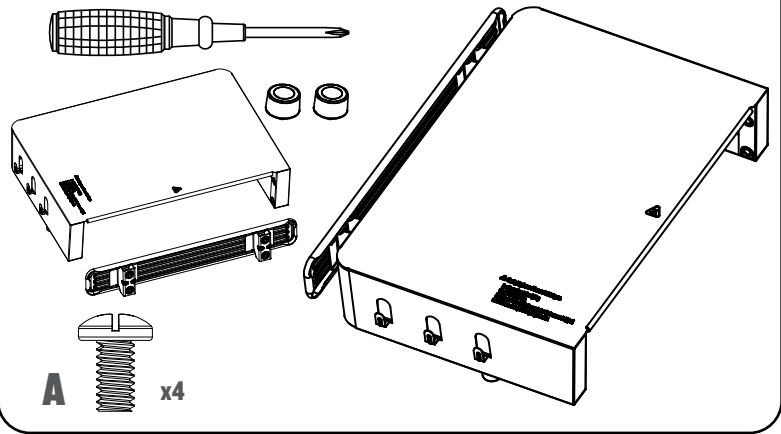

 **PRO TIP:** Push bumpers in while turning so bumpers insert fully.

12 ATTACH FOLDING SIDE SHELF BRACKETS

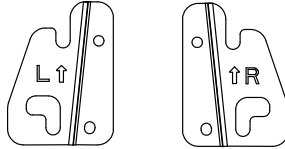
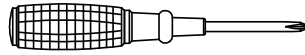

A x4

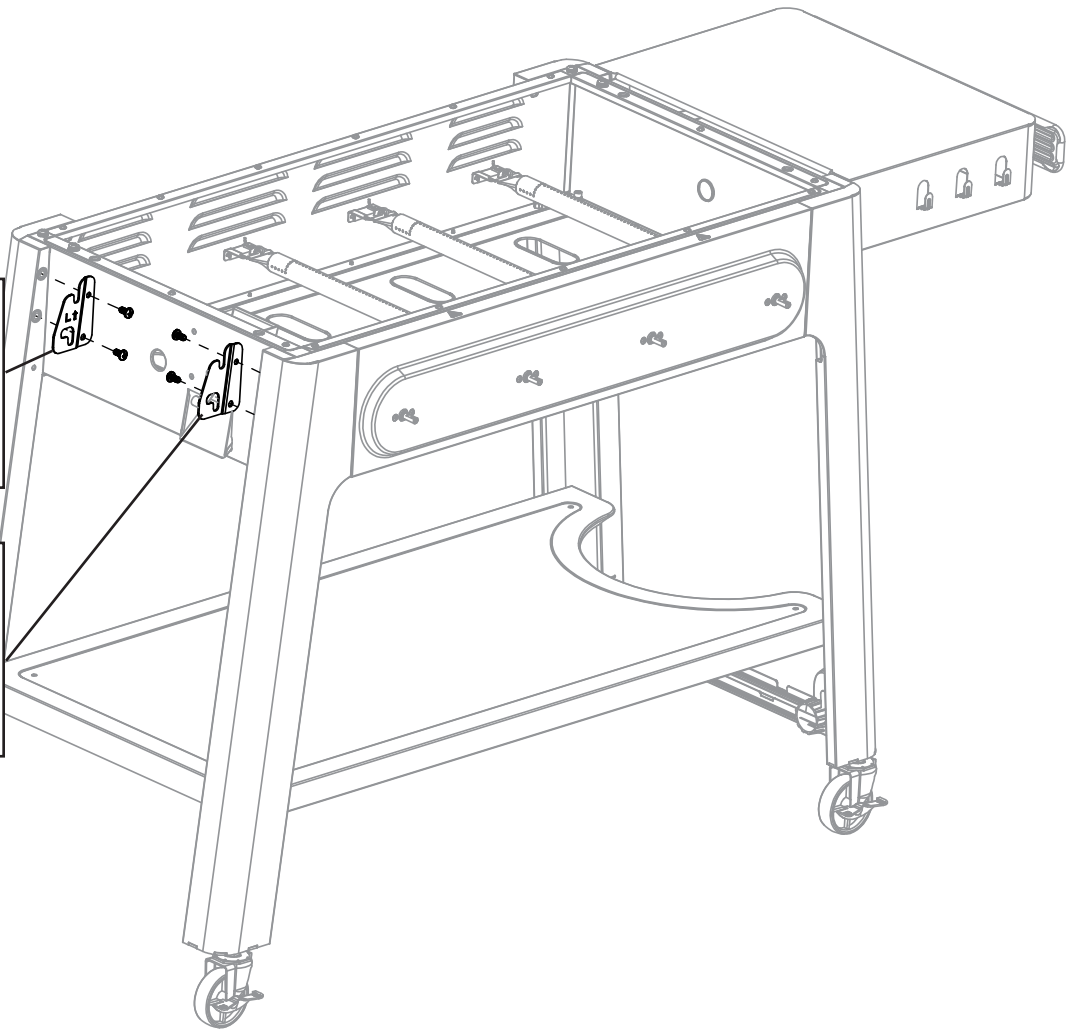
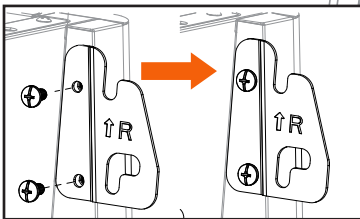
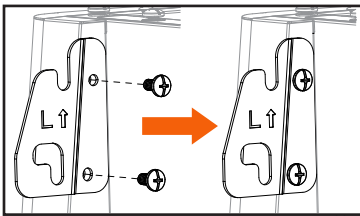
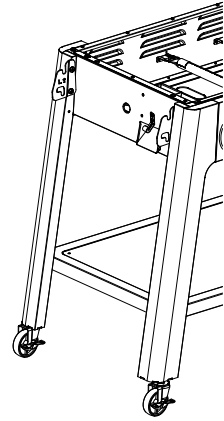

13 ATTACH FOLDING SIDE SHELF

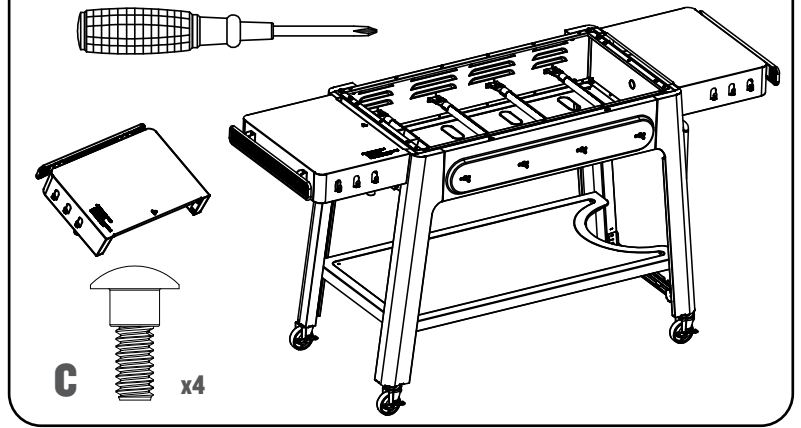

13A

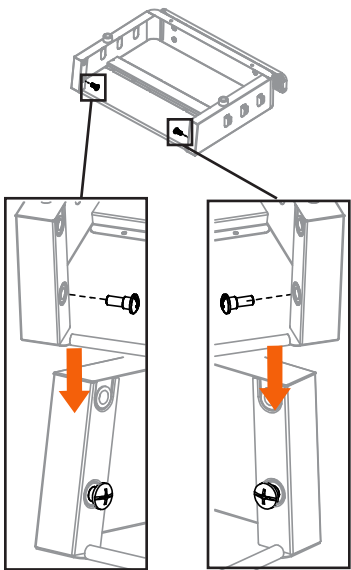

13B

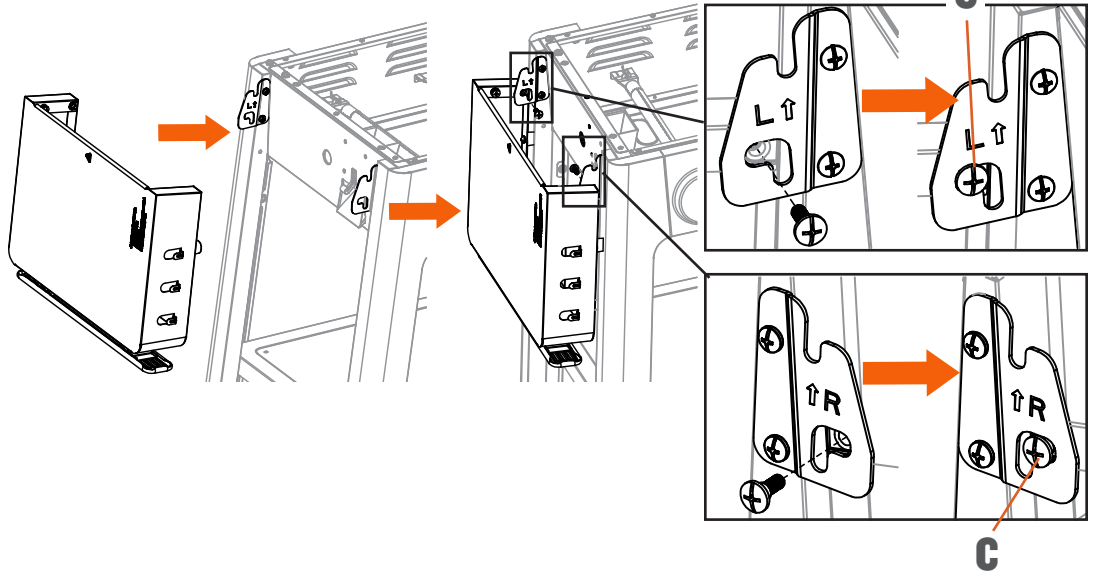

13C

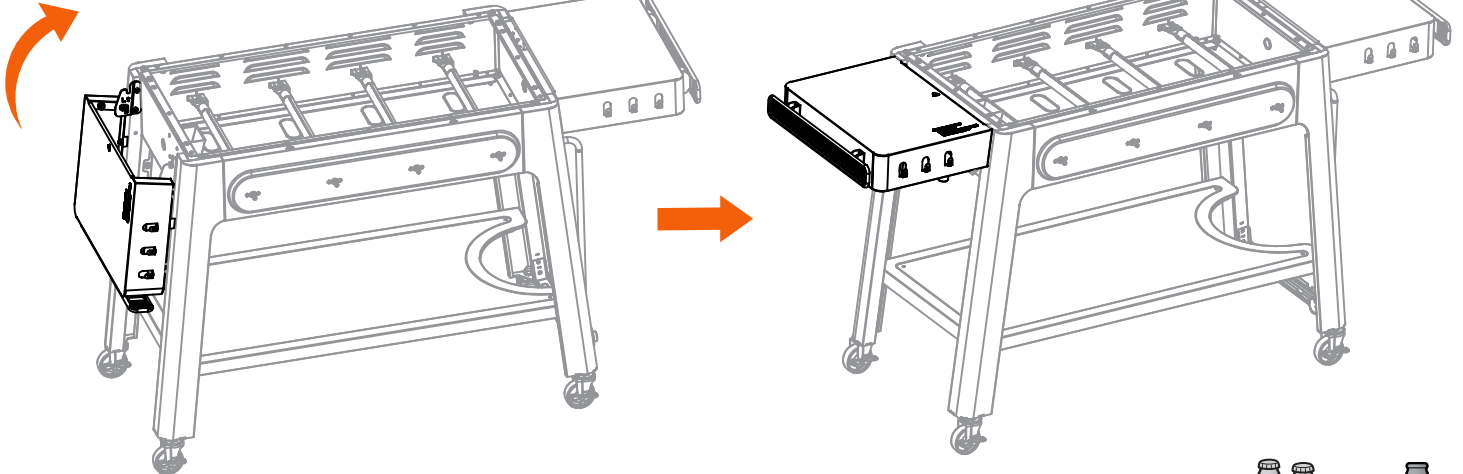

PRO TIP: After swinging shelf up, press down to secure screws in brackets.

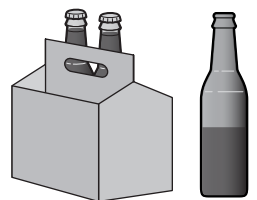

14 ATTACH GUIDE BARS

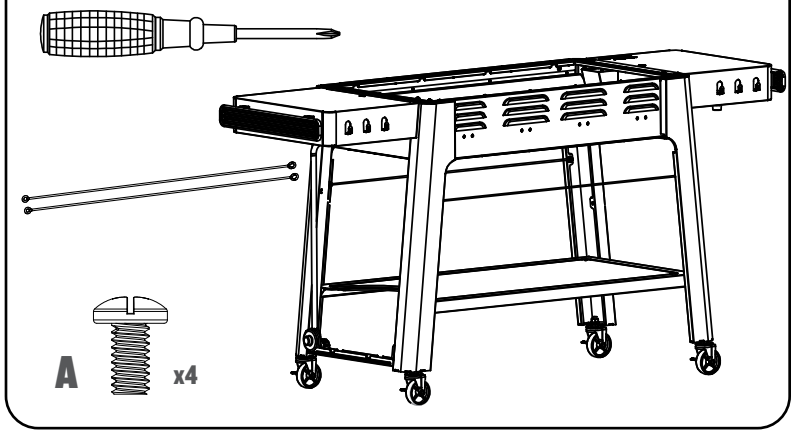

14A

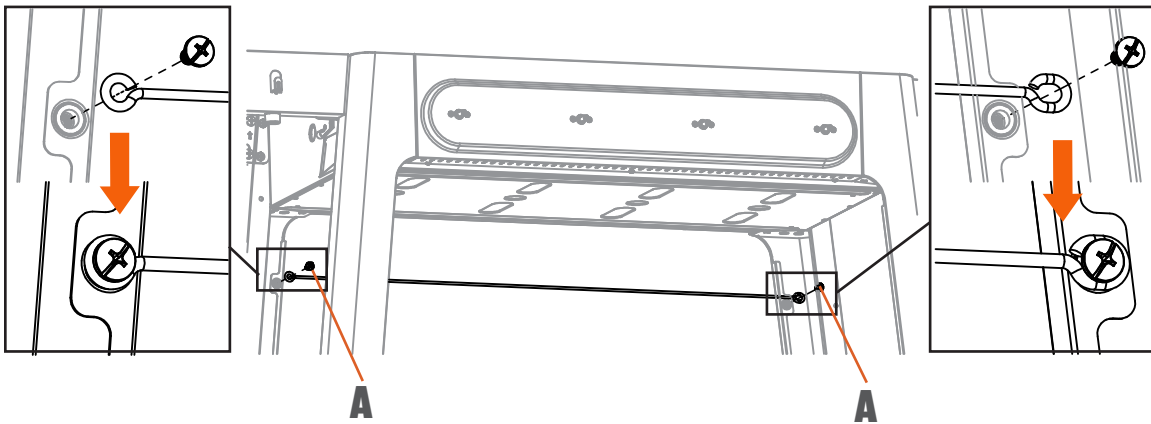

14B

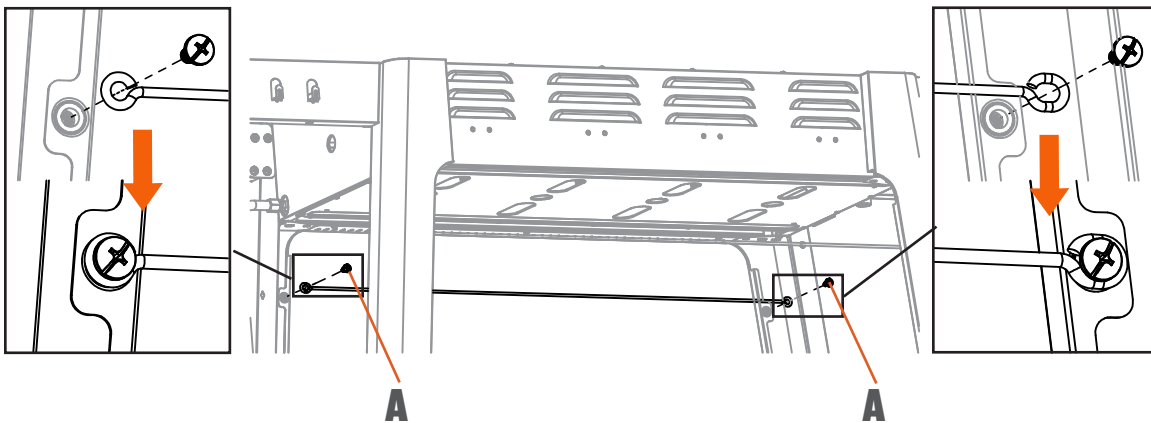

15 ATTACH SHORT TANK RETENTION ROD AND PROPANE TANK WIRE

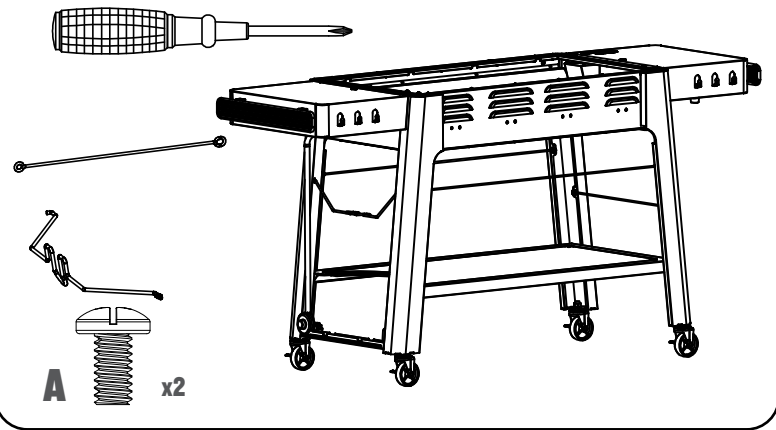

15A

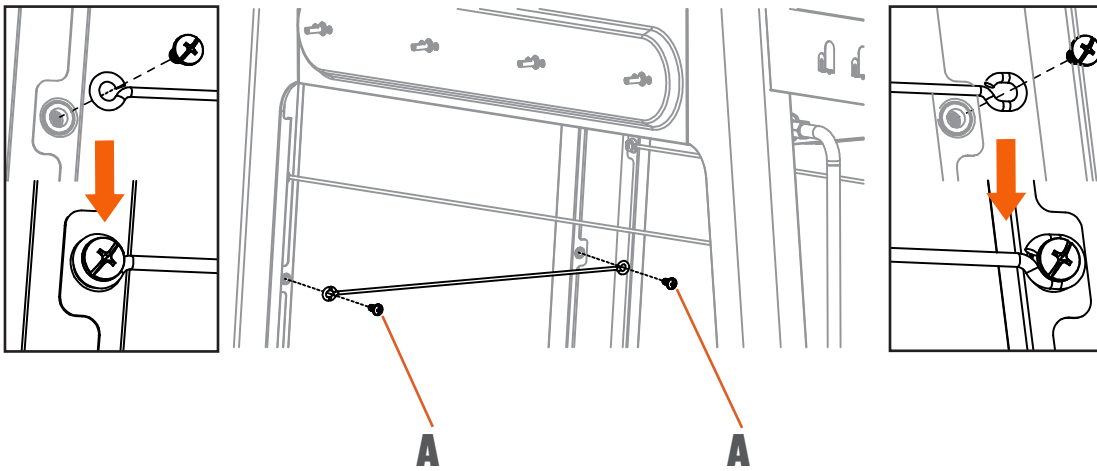

15B

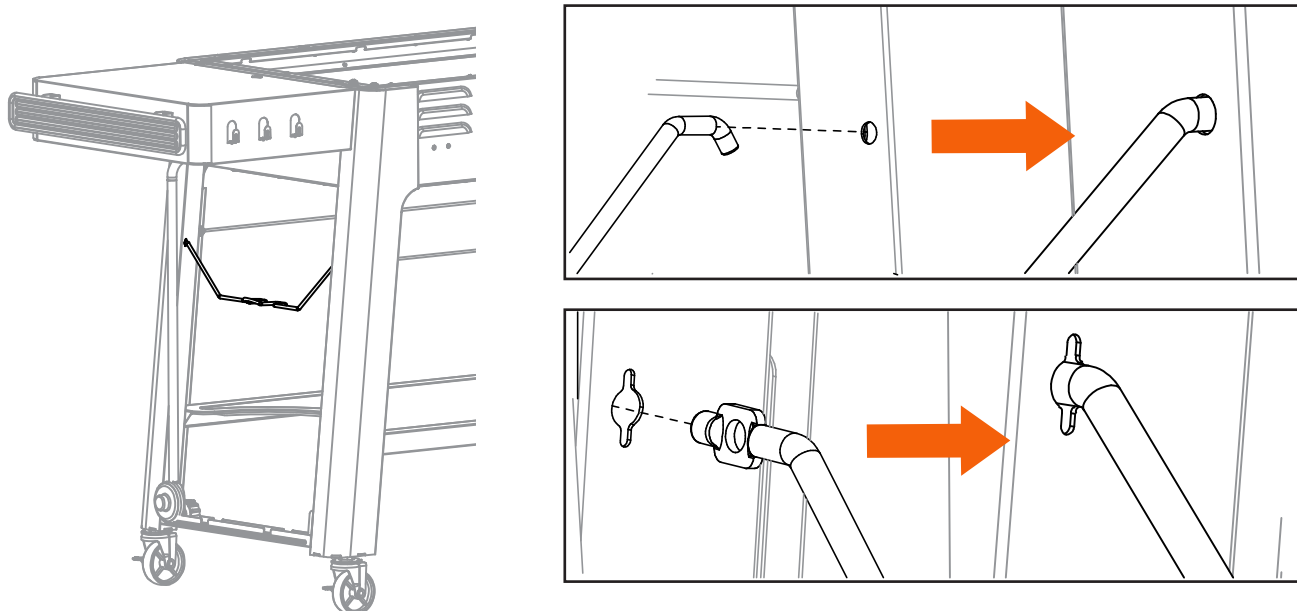

16 ATTACH BACK Baffle Plate

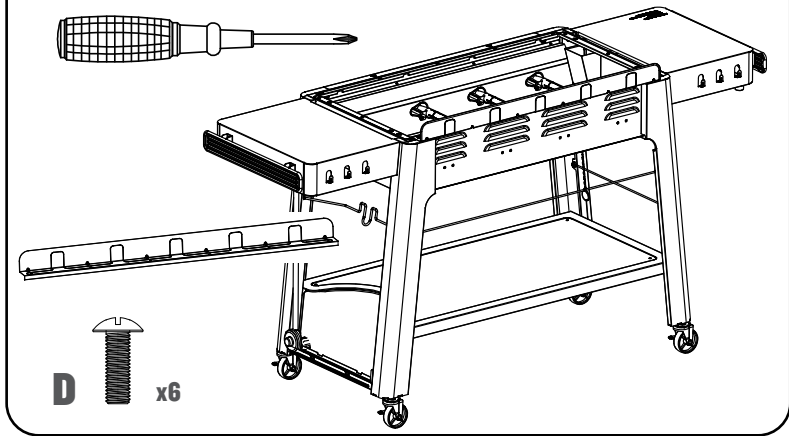

FOR 4-BURNER GRILLS

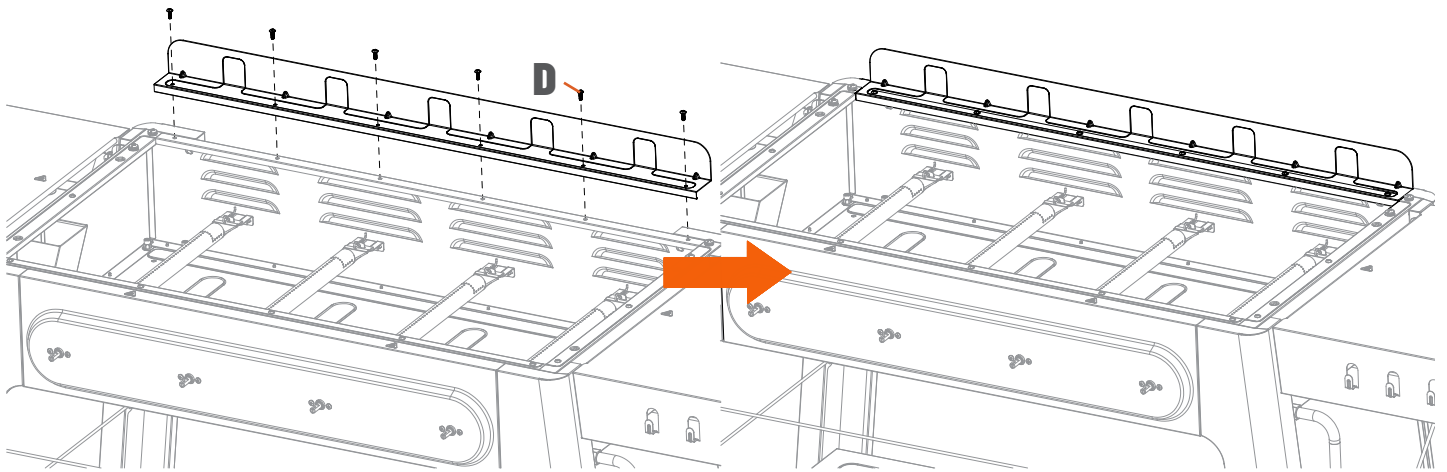

FOR 2-BURNER GRILLS

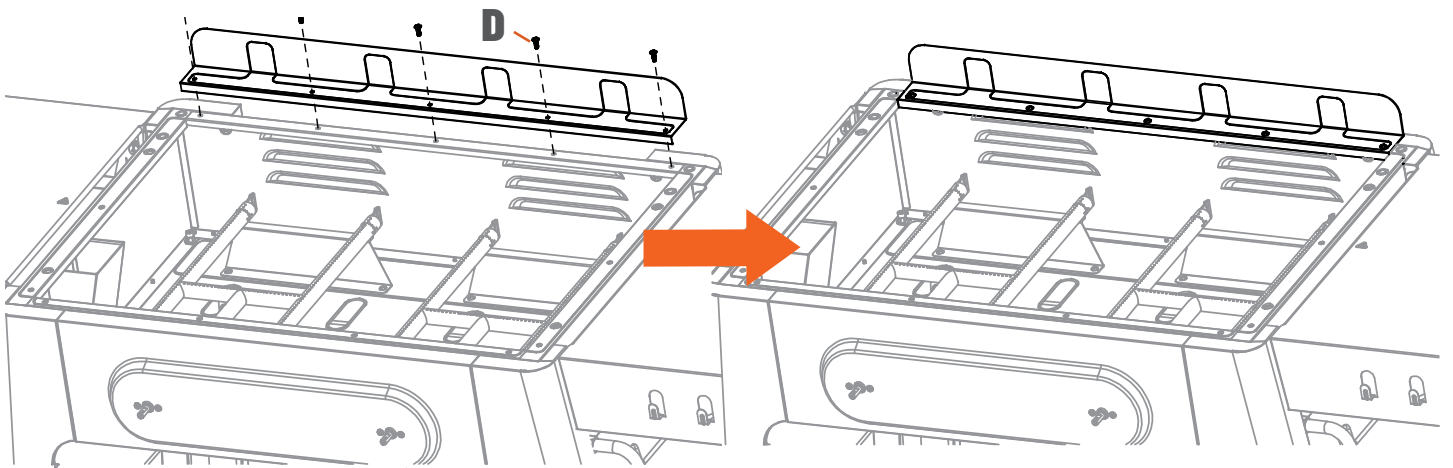

17 ATTACH LID HANDLE

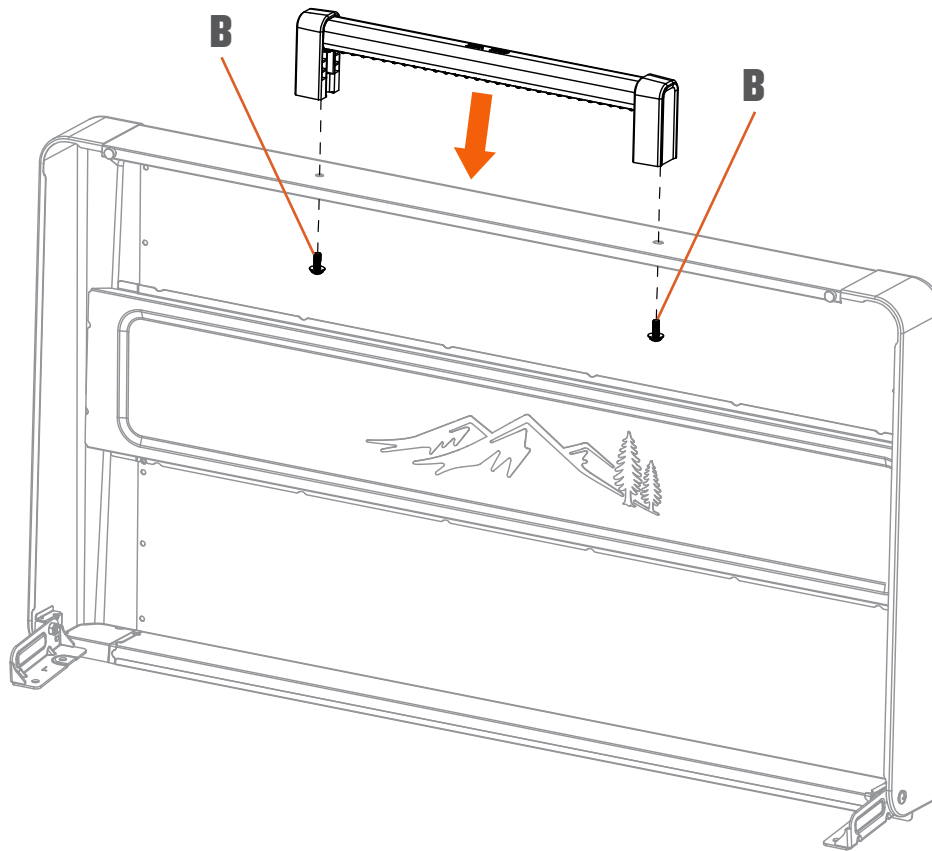
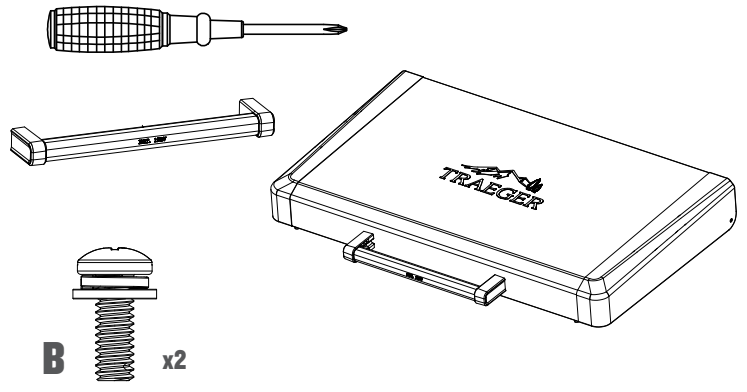



PRO TIP: Use two people to attach the lid.

⚠ WARNING Risk of Burn Injury

Do not close the lid when preheating or operating the grill, as lid and handle will become very hot. Only close lid to protect grill surface when grill is turned off and is cool to the touch.

18 ATTACH LID

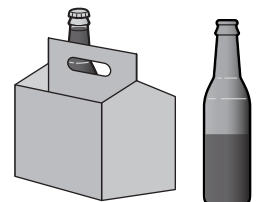
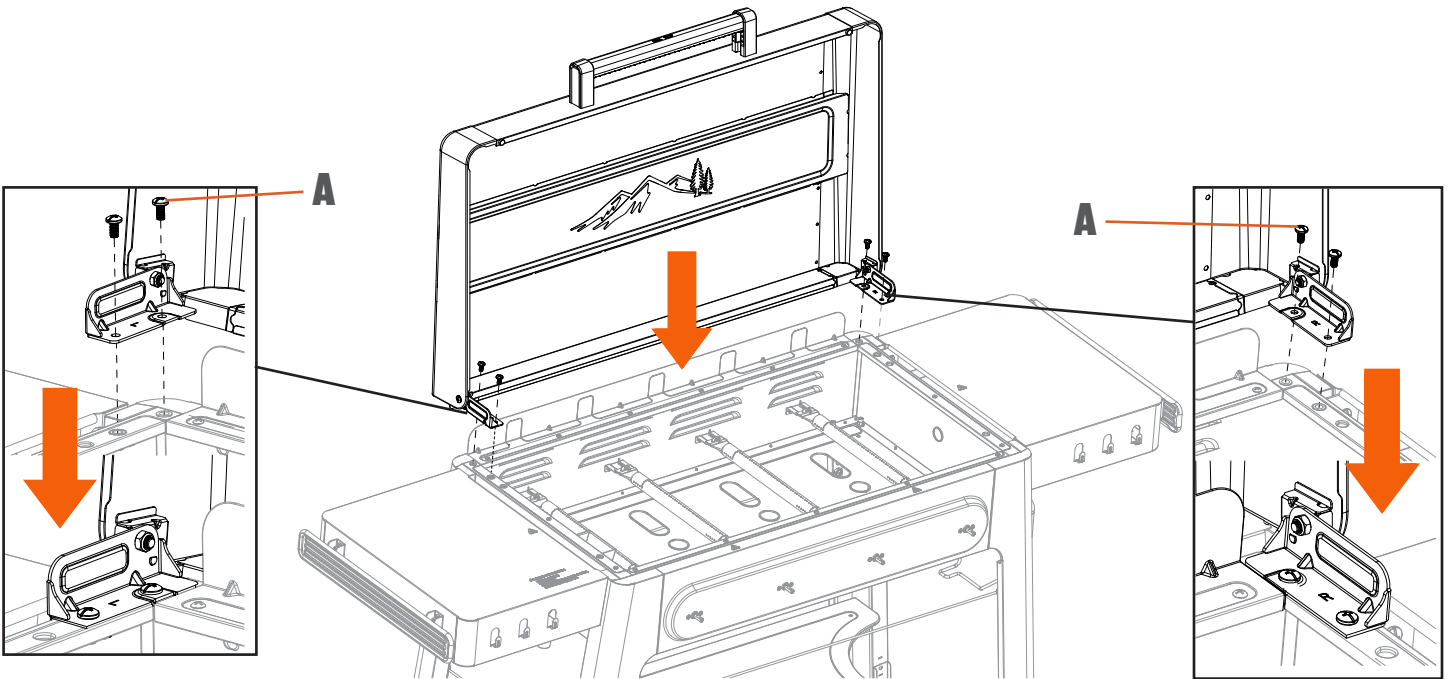
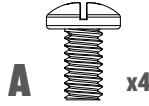
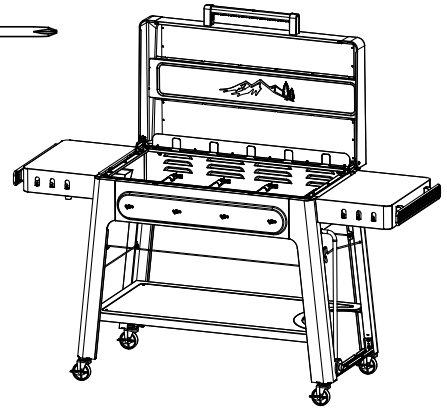
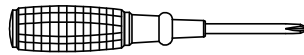

19 INSTALL COOKTOP

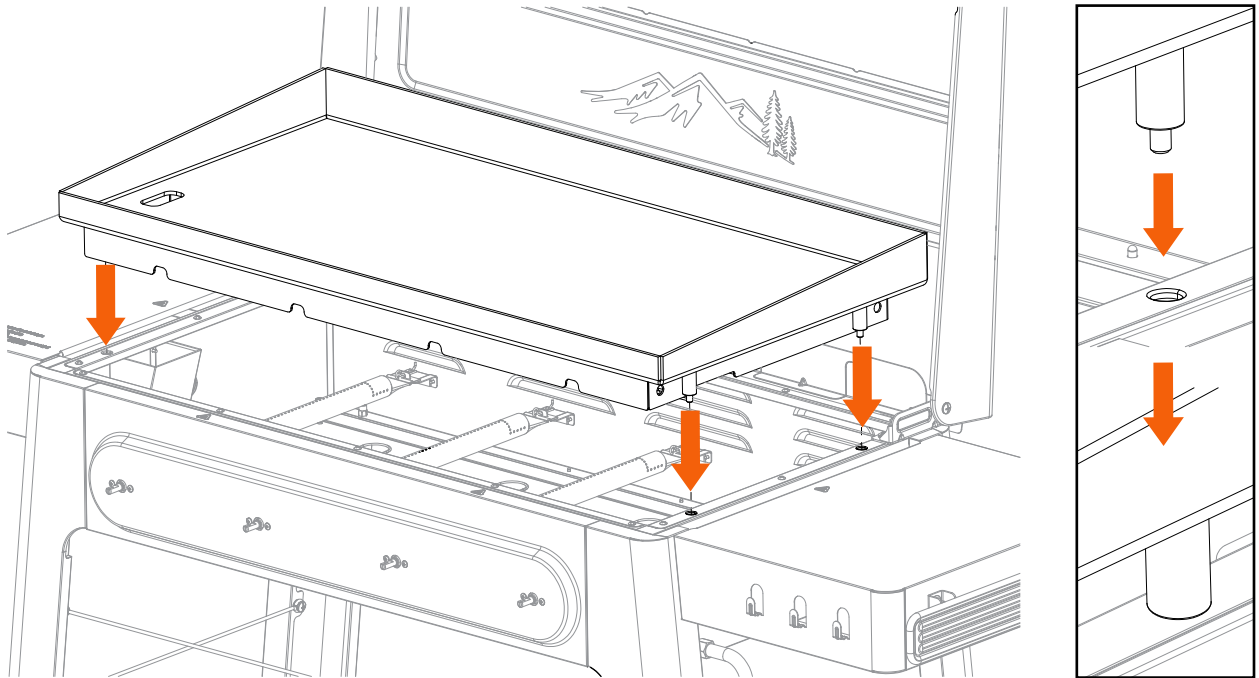
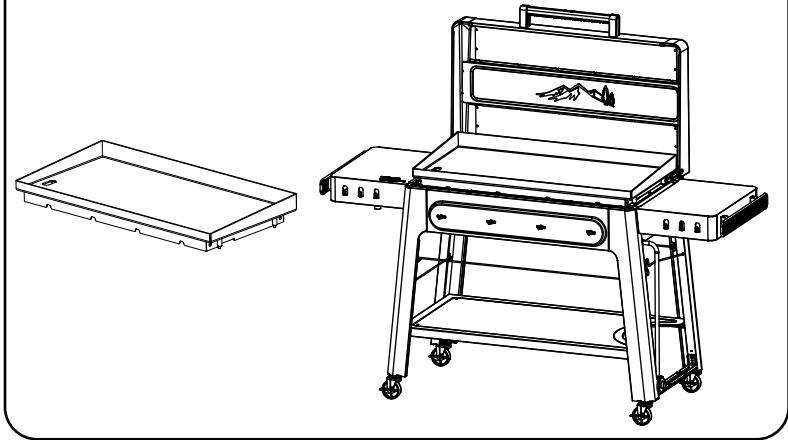

20 HANG GREASE BUCKET

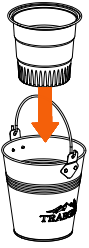

PRO TIP: Additional bucket liners are available for purchase at traeger.com.

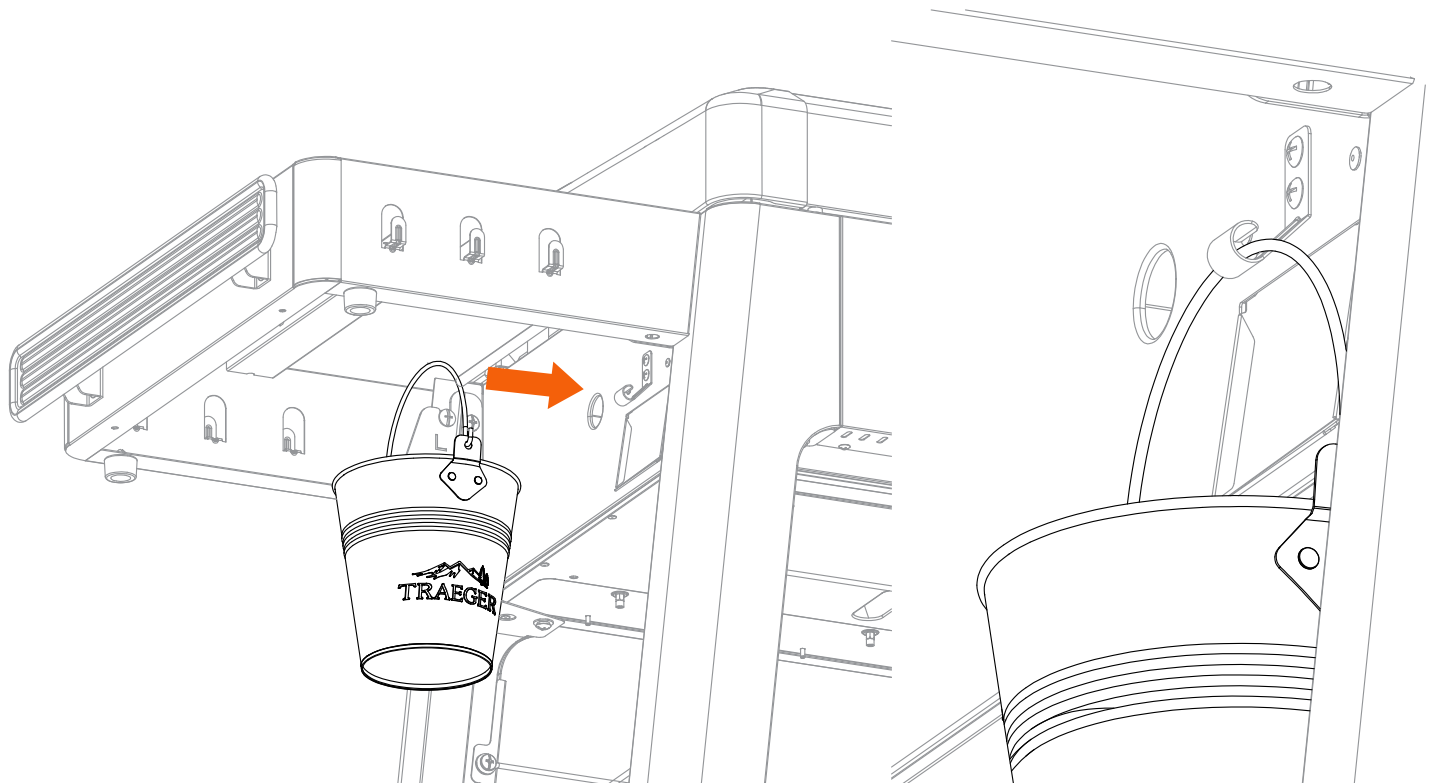
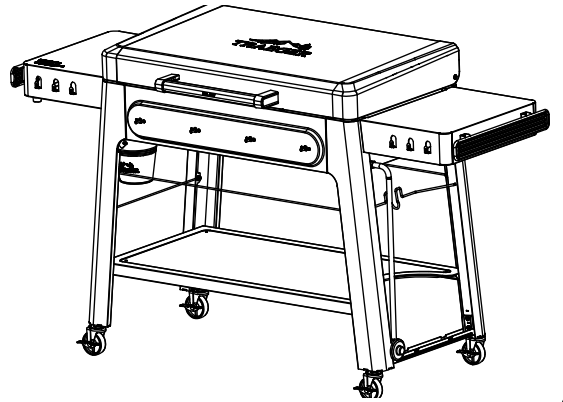

PRO TIP: Grease bucket will become hot while grill is in use. Do not handle until grill has completely shut down and is cool.

21 INSTALL CONTROL KNOBS

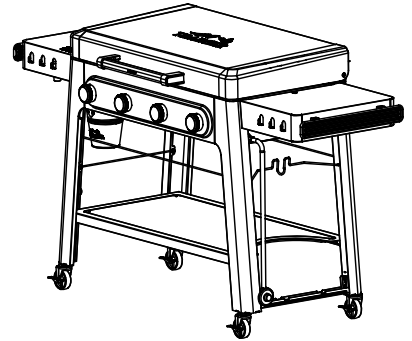
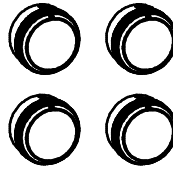

FOR 4-BURNER GRILLS

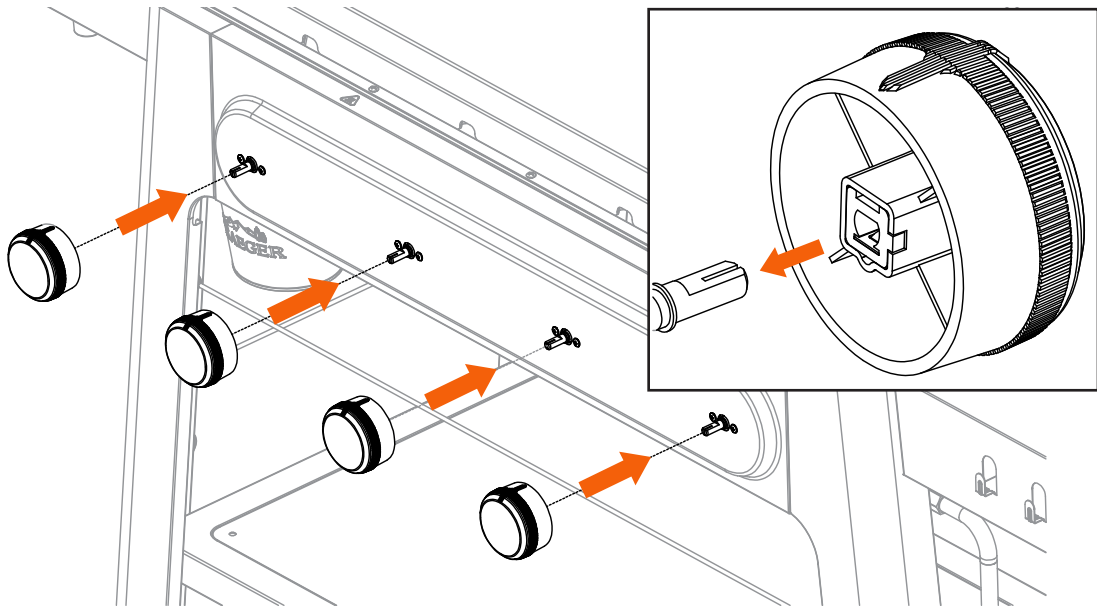

FOR 2-BURNER GRILLS

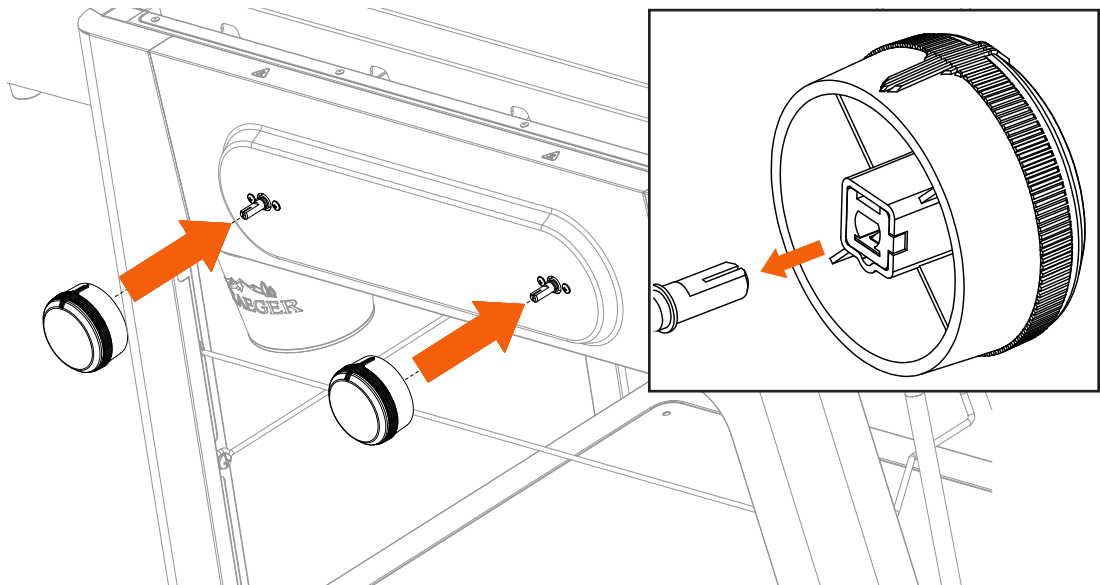

22 INSTALL PROPANE TANK

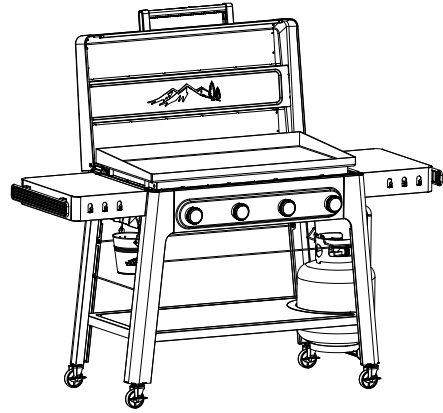

22A

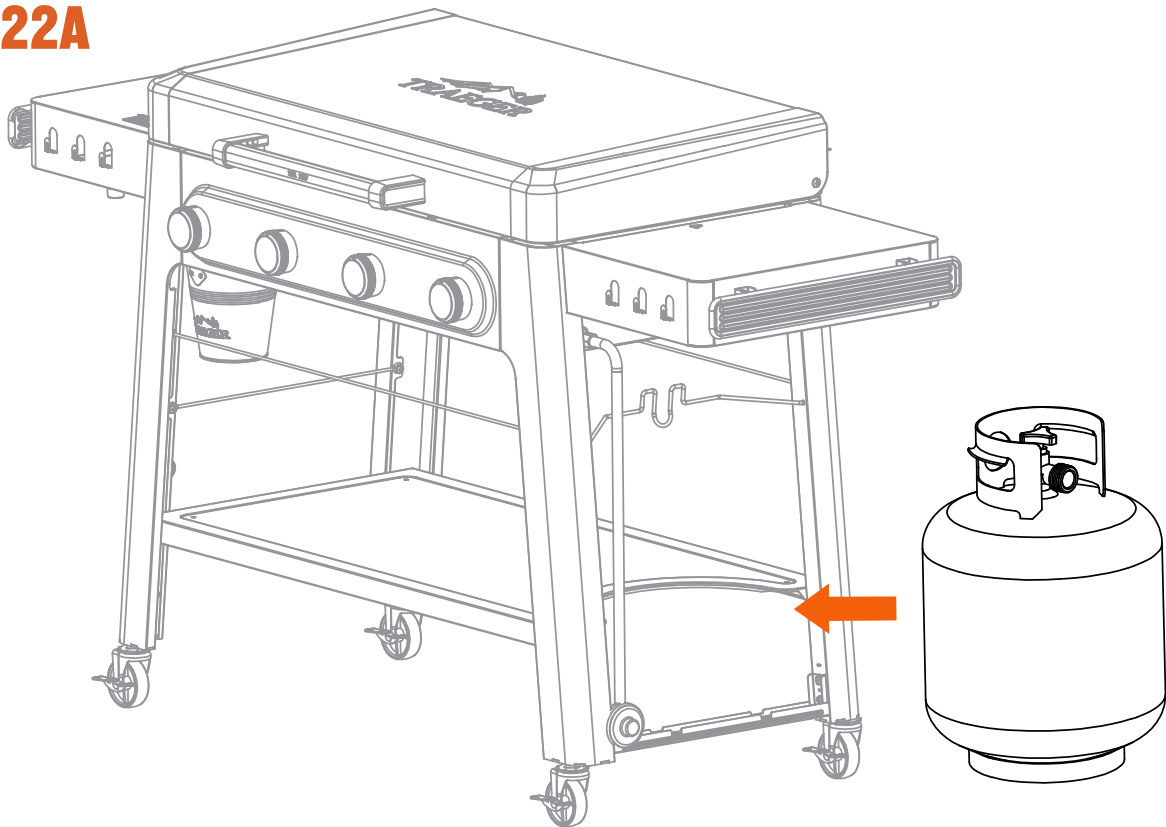

22B



22D

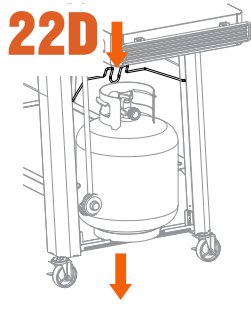

22F

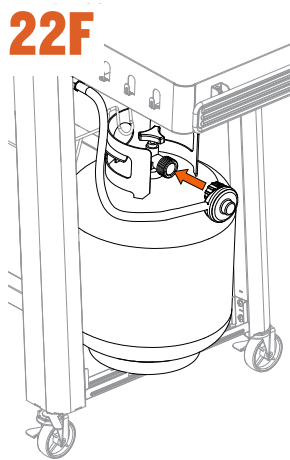

22C

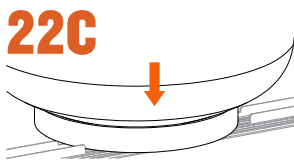

22E

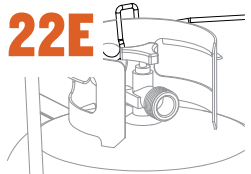

CHECKING FOR GAS LEAKS

⚠ WARNING Fire Hazard

NEVER use an open flame, such as a lighted match, to test for leaks.

The following diagram is for informational purposes only. These locations are not the only points to check, nor the only potential areas for a gas leak to be present. Ensure the leak test includes all valves, pipe connections, joints, lines, and every point from the gas source to the burners.

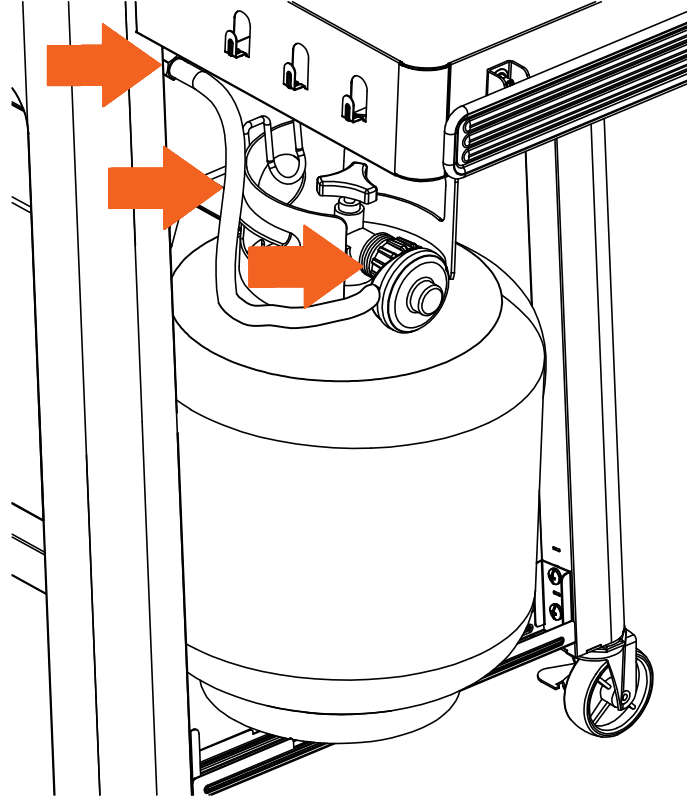

**NICE WORK!
YOU'RE READY TO GO!**

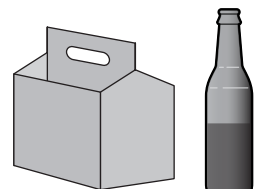

GETTING TO KNOW YOUR IRONTOP™ GRILL

PARTS AND FEATURES

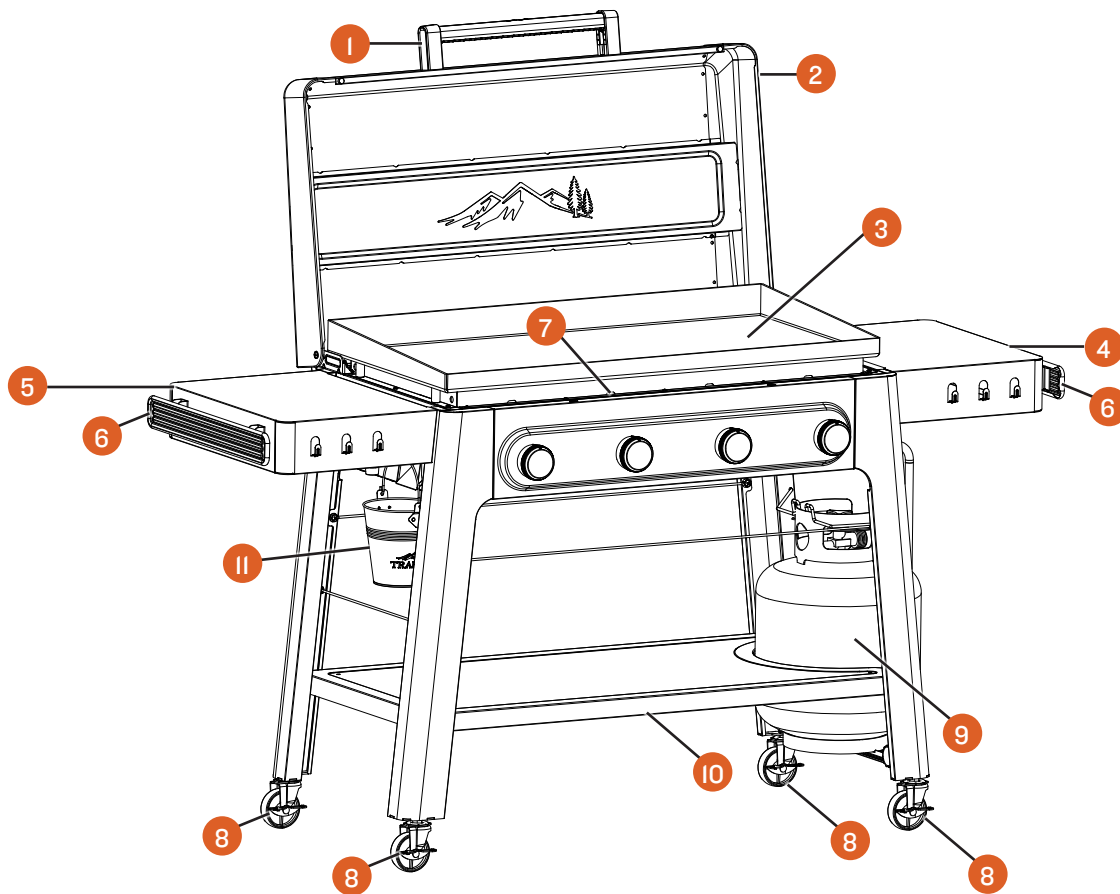

4-Burner Model shown

PART	DESCRIPTION	PART	DESCRIPTION
1	LID HANDLE	7	FLAME VIEW OPENINGS
2	GRILL LID	8	LOCKING CASTER
3	COOKTOP	9	LIQUID PROPANE (LP) GAS TANK (NOT INCLUDED)
4	RIGHT STATIONARY SIDE SHELF	10	BOTTOM SHELF
5	LEFT FOLDING SIDE SHELF	11	GREASE BUCKET
6	P.A.L. POP-AND-LOCK™ ACCESSORY RAIL		

WEIGHT CAPACITIES

Side Shelves: 20 lbs (9 kg)

Bottom Shelf Components:

Propane Tank Rest – One Standard Tank: ~40 lbs (18 kg)

Total Bottom Shelf Capacity: 50 lbs (23 kg)

GETTING TO KNOW YOUR IRONTOP™ GRILL CONTINUED

CONTROL PANEL

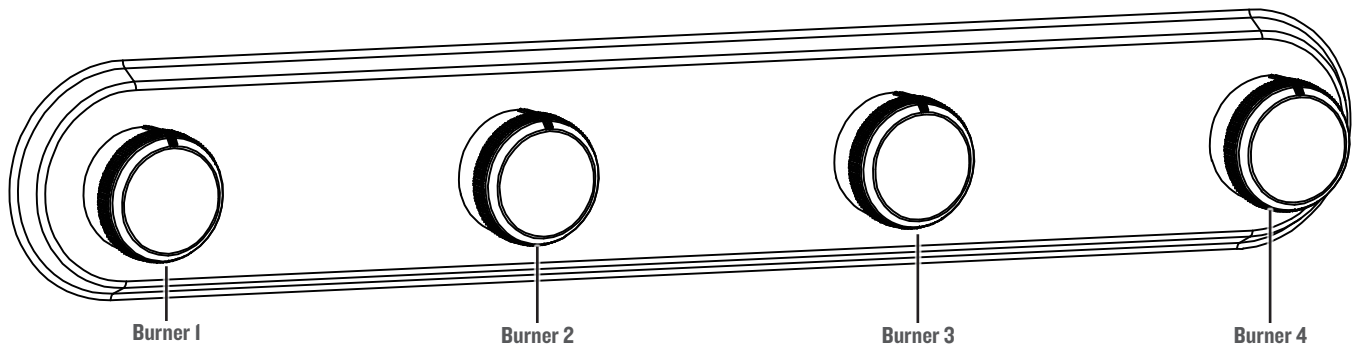

4-Burner Model shown

PROPANE TANK AND FITTINGS

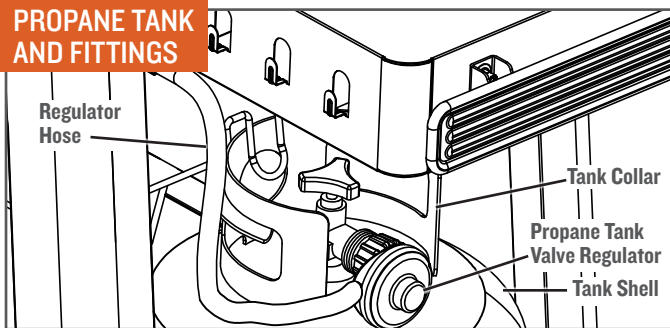

The IronTop™ Grill can be used with any standard 20 lb (9 kg) propane tank. It must be a maximum of 12 1/4 in. in diameter; 18 in. high, with right-handed connection threads, and a collar. The tank must be marked in accordance with the latest U.S. Department of Transportation specifications for LP gas tanks or DOT. CFR49 or National Standards of Canada CAN/CSA-B359 Cylinders, Spheres and Tubes for the

Transportation of Dangerous Goods. A Liquid Propane Tank with an OPD (Overfill Prevention Device) must be used at all times. If your IronTop™ Grill is for liquid propane application, an LP regulator set for 11 in. WC and LP gas use only must be used. You can typically purchase a new propane tank at your local gas station, supermarket, or stores where outdoor gas appliances are sold. Once you have purchased a propane tank, when empty, you can either exchange it for a new, full tank or have it refilled at your local gas supplier.

NOTE: When deciding between refilling and exchanging a propane tank, keep in mind that local suppliers may not fill the tank 100% full.

INSTALLING OR REMOVING PROPANE TANK

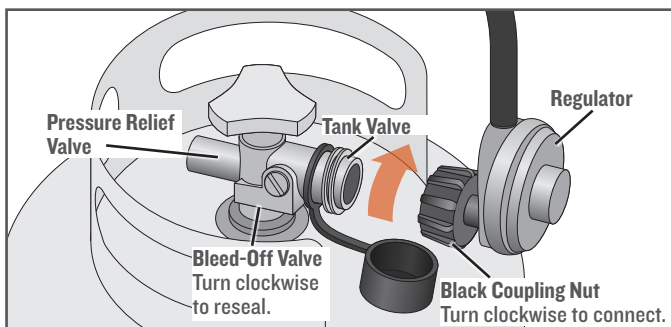

To Connect

1. Ensure that there is no debris caught in the head of the gas tank and head of the regulator valve.
2. Insert the nipple of the valve coupling into the tank valve and tighten the black coupling nut by turning it clockwise with one hand while holding the regulator with the other hand. Hand-tighten only.

To Disconnect

1. Always confirm that the tank valve is in the "OFF" position before disconnecting the gas supply.
2. Hold the regulator with the one hand and loosen the black coupling nut by turning it counterclockwise with the other hand.

IMPORTANT: Disconnect the propane tank from the regulator valve when the appliance is not in use.

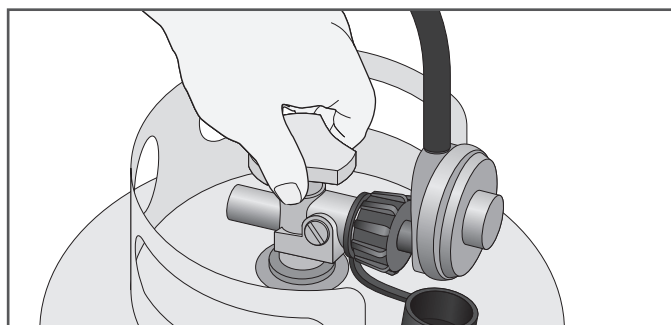

IRONTOP™ GRILL FEATURES

FOLDING SHELF

The left side shelf of your IronTop™ Grill folds for easy storage. To fold your shelf, lift straight up to disengage from the shelf brackets and fold down (use both hands—one on the back and one on the front of the shelf). Make sure to remove accessories from the P.A.L. rail before folding the shelf.

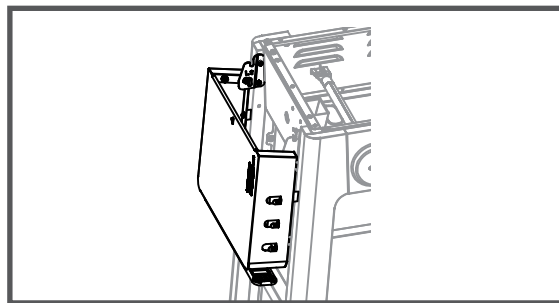

P.A.L. RAILS

Traeger's accessory rails allow you to hang tools, storage bins, and more. Check traeger.com for great accessories to get the most out of your Traeger® IronTop™ Grill.

⚠ WARNING Do not use P.A.L. accessory shelves. They are not compatible with this IronTop™ Grill.

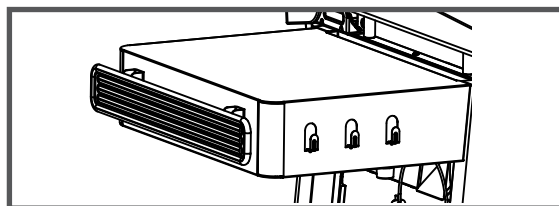

REGISTER YOUR IRONTOP™ GRILL

Use the free Traeger App to open a whole new flavor frontier. Register your Traeger® IronTop™ Grill for a guided onboarding process, digital assembly guides, a multitude of new recipes, and more.

Scan this QR code or visit www.traeger.com/register-grill to register your IronTop™ Grill:

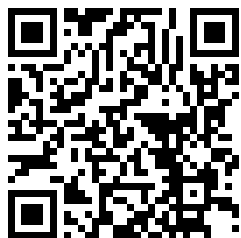

PRO TIP: You'll need your serial number to register your IronTop™ Grill. This can be found on the bottom shelf.

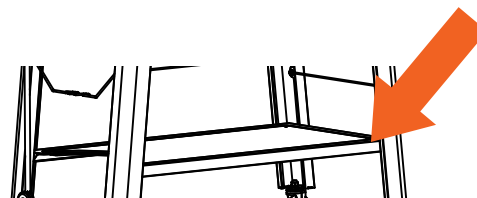

ONBOARDING 1: INSTALLING PROPANE TANK

REQUIRED PRIOR TO FIRST COOK

PRO TIP: Open the free Traeger App to register your Traeger® IronTop™ Grill and complete a guided onboarding process.

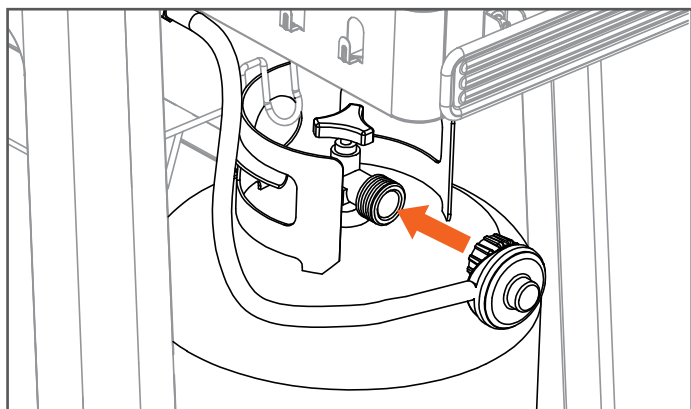

See Step 22, “Install Propane Tank” in Assembling Your Grill section for step-by-step instructions. Be sure all control knobs are in the OFF (0) position. Screw the end of the regulator onto the propane tank valve. Hand-tighten.

PROPER ORIENTATION FOR VAPOR WITHDRAWAL

- Propane tanks designed for vapor withdrawal **must be used in the vertical, upright position**. This ensures the vapor space is at the top of the tank, allowing only gas (not liquid) to exit through the service valve.
- The service valve should be at the highest point of the tank.
- **Tilting or laying the tank horizontally** can cause liquid propane to be withdrawn, which is unsafe and can damage equipment, or cause bodily harm.

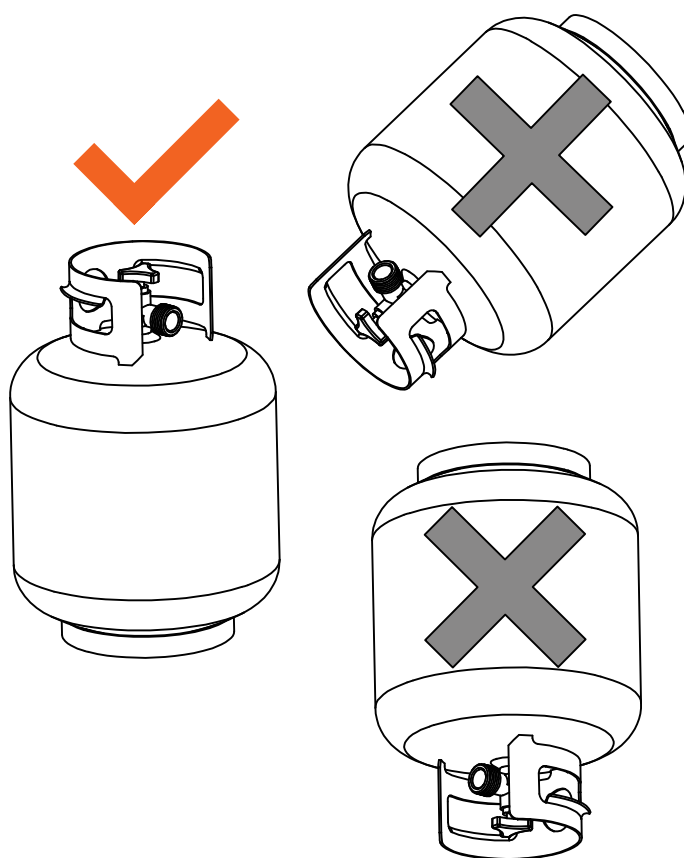

WHEN PROPANE TANK IS NOT IN USE

Place a dust cap on the tank valve outlet. Only install the type of dust cap that is provided with the tank valve. Other types of caps or plugs may result in propane leaking.

WHEN REPLACING OR REFILLING AN LP GAS TANK

Check the rubber seal in the tank valve. Over time, the seal could show marked and visible damage or deterioration that might cause a leak, even with the connection tightened. If damage or deterioration is present, including visible cracks and pitting, do not use the tank and return it to the seller.

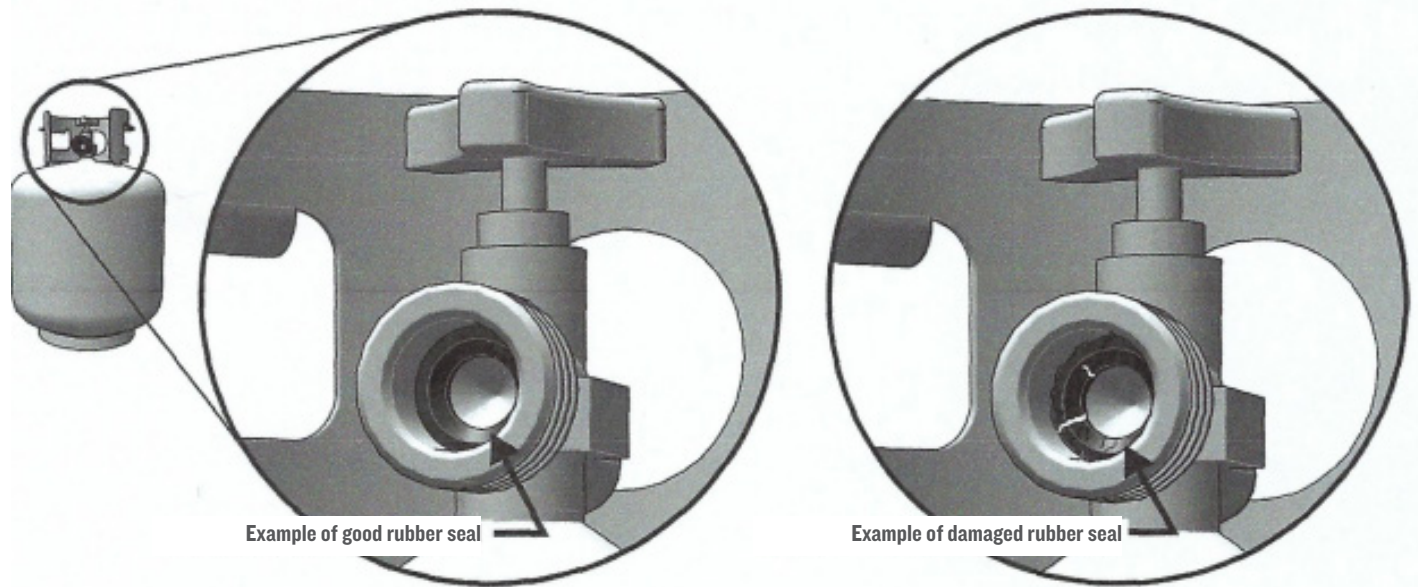

CHECKING FOR GAS LEAKS

⚠ WARNING Fire Hazard

NEVER use an open flame, such as a lighted match, to test for leaks.

The following diagram is for informational purposes only. These locations are not the only points to check, nor the only potential areas for a gas leak to be present. Ensure the leak test includes all valves, pipe connections, joints, lines, and every point from the gas source to the burners.

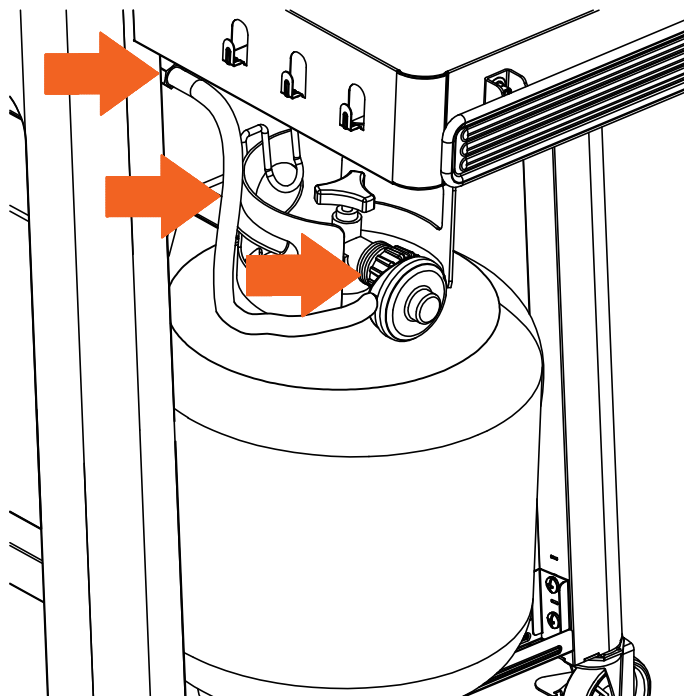

ONBOARDING I: INSTALLING PROPANE TANK CONTINUED

CHECKING FOR GAS LEAKS (CONT.)

Perform a leak test after a new tank is added, after service, or following a period of non-use to ensure that there are no gas leaks. In addition, whenever the gas tank is connected to the regulator or whenever any part of the gas system is disconnected or replaced, perform a leak test.

⚠ DANGER

If you smell gas:

- **Shut off gas to the appliance.**
- **Extinguish any open flame.**
- **Open lid.**
- **If odor continues, keep away from the appliance and immediately call your gas supplier or your fire department.**

⚠ WARNING Fire Hazard

Always leak test your appliance outdoors in a well-ventilated area. **NEVER** smoke or permit sources of ignition in the area while doing a leak test. **DO NOT** use an open flame, such as a lighted match, to test for leaks. Use a solution of soapy water.

- Check hose for signs of abrasions, cracks, or leaks. Replace if worn.
- Prepare a leak testing solution of soapy water by mixing one part liquid soap to one part water in a spray bottle.
- Make sure all control knobs are in the OFF (○) position.
- Turn the LP tank valve knob counterclockwise one turn to open.
- Apply the leak-testing solution by spraying or brushing it on joints of the gas delivery system. This includes all valves, pipe connections, joints, lines and every point from the gas source to the burners.

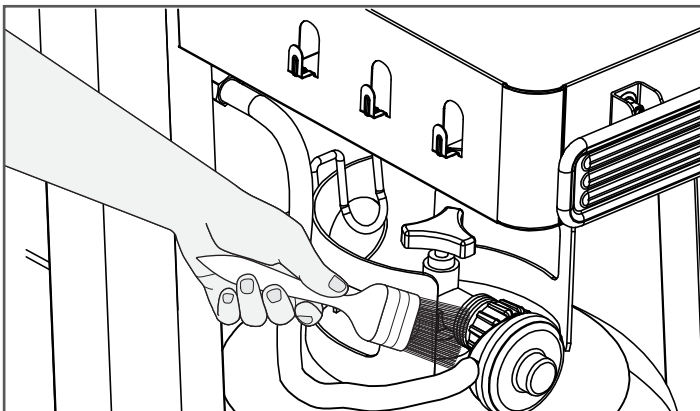

- Bubbles appearing in the soap solution and/or a faint gas smell (typically, gas has a rotten egg smell) indicates that a leak is present. Do not attempt to ignite the IronTop™ Grill.
- Do not use the appliance until the leak is corrected.
- Stop a leak by tightening the loose joint and/or resealing with thread sealant, removing sealant in the event of a flared connection, or by replacing the faulty part with a replacement part recommended by the manufacturer. Do not attempt to repair the tank valve if it is damaged. The tank must be discarded at a proper LP tank location and then replaced.
- If you are unable to stop a leak, turn the tank valve knob clockwise until it is fully closed, shut off the gas supply to the appliance, and release pressure in the hose and manifold by pushing in and turning any of the control knobs one quarter turn counterclockwise.
- Remove the LP tank from the appliance.
- Call an authorized gas appliance service technician or an LP gas dealer.
- All leaks must be corrected immediately. Remember: before exchanging an empty tank for a new one, make sure all valve knobs are in the closed position. Leaving valve knobs open can create a low flow of gas through the IronTop™ Grill, which would require the tank to be disconnected from the regulator, and then reconnected to reset the regulator.

ONBOARDING 2: SEASONING YOUR IRONTOP™ GRILL

ALSO REQUIRED PRIOR TO FIRST COOK

In order to ensure the best flavor, optimal performance, and proper and safe operation of the IronTop™ Grill, follow the instructions below to season your IronTop™ Grill.

NOTE: This seasoning process is important to ensure proper IronTop™ Grill performance. Seasoning the cooktop makes it naturally nonstick and keeps out excess moisture, which can cause rust. Make sure that all internal components have been properly installed prior to the seasoning process and that there is no food on the IronTop™ Grill during seasoning.

TOOLS NEEDED

- Traeger® IronTop™ Grill Seasoning & Cast Iron Conditioner or canola oil
- Clean towel or paper towel
- Metal tongs
- Watch or timer

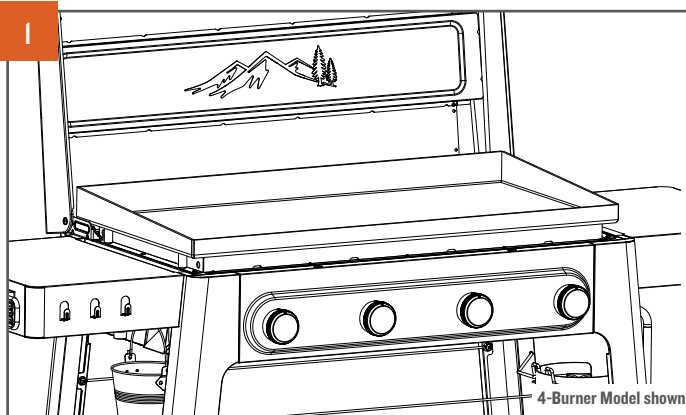

Preheat the IronTop™ Grill on high for 10 minutes. Make sure the propane tank valve has been turned to the fully open position. Press the control knob and rotate slowly (2-3 seconds) to the ignite position (🔥). Turning the knob opens the control valve and activates the igniter. Look at the burner through the flame view opening to confirm that the burner has successfully lit. If the burner did not light, turn the control knob back to the OFF (○) position and repeat until burner ignition is confirmed.

⚠️ WARNING Risk of Burn Injury

Do not close the lid when preheating or operating the grill, as lid and handle will become very hot. Only close lid to protect grill surface when grill is turned off and is cool to the touch.

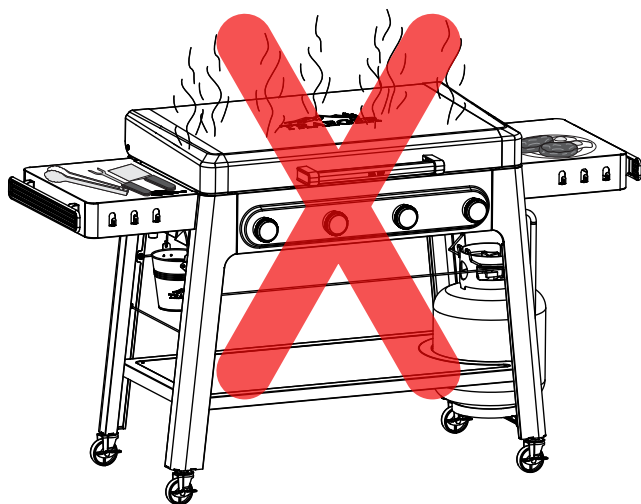

⚠️ WARNING Fire Hazard

- If the IronTop™ Grill does not ignite within 5 seconds, turn burner controls OFF (○), wait 5 minutes to allow gas to dissipate, and repeat ignition procedure. If IronTop™ Grill does not ignite, gas will continue to flow out of burner and could accidentally ignite.

TO MANUALLY LIGHT BURNERS

Burners can be manually lit by using long matches or a long neck utility lighter. Access the burner through the opening located on each side of the grill cavity. Confirm that the burner has successfully lit by looking through the flame openings under the cook surface until you see the flame.

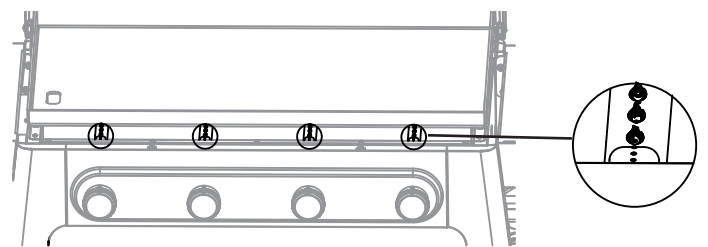
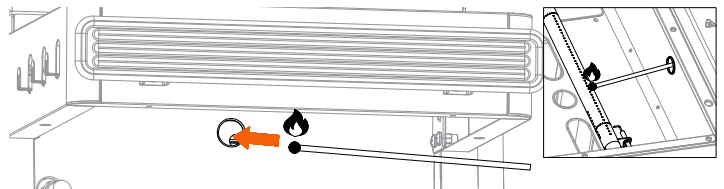

ONBOARDING 2: SEASONING YOUR IRONTOP™ GRILL CONTINUED

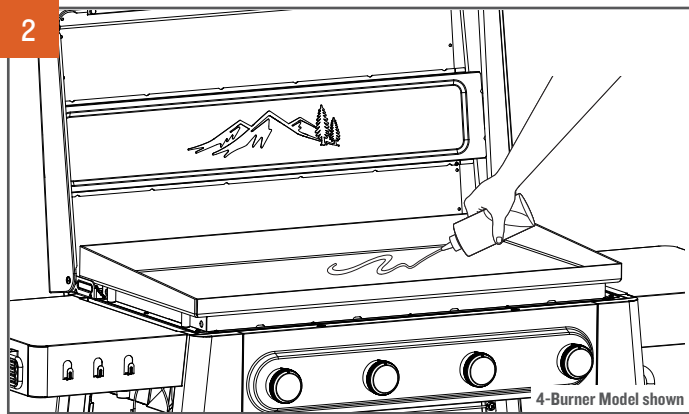

Once the IronTop™ Grill is hot, squeeze about 2-3 Tbsp of the conditioner or your oil over the cooktop in a zigzag pattern, covering the entire cooktop.

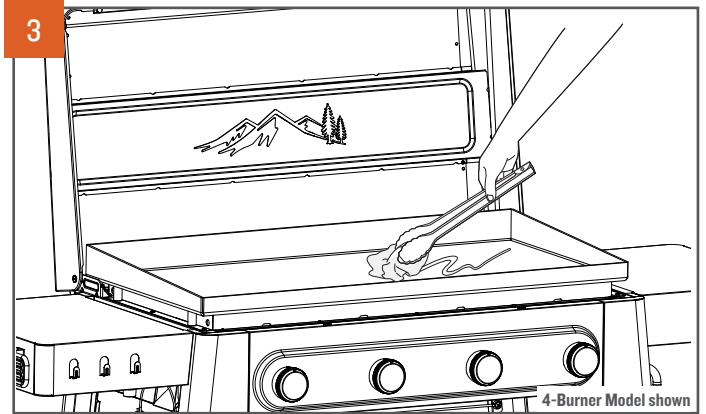

Using tongs clasping a clean towel or paper towel, spread the conditioner evenly over the surface and up the sides. It will immediately begin to smoke. Using a clean side of the towel, wipe off any excess conditioner or oil to create a very thin layer.

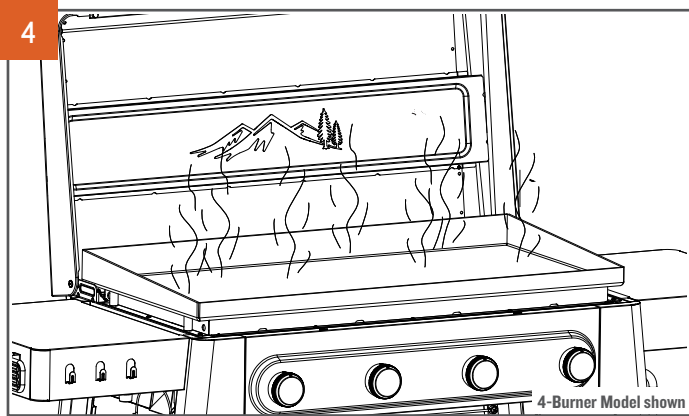

Continue heating until the smoking ends—about 10-15 minutes.

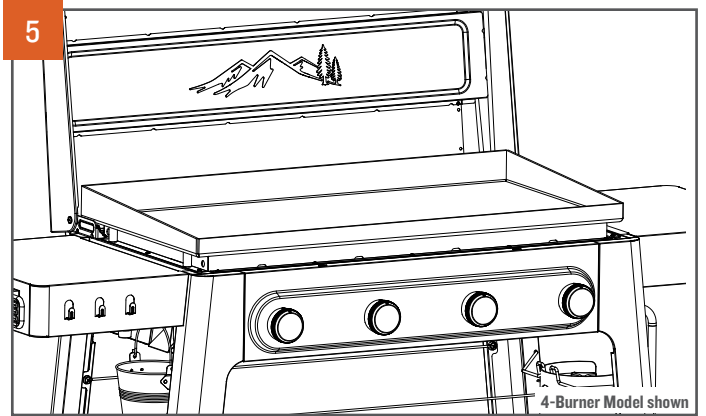

Leaving the heat on high, repeat the oiling and smoking for a total of five times. The surface will become darker and smoother.

PRO TIP: Let the cooktop cool for at least 30 minutes before cooking on it.

USING YOUR IRONTOP™ GRILL

YOU WILL NEED TO BEGIN WITH THESE STEPS EVERY TIME YOU USE YOUR IRONTOP™ GRILL.

PRE-GRIDDLING CHECKLIST

1. Perform needed maintenance:
 - Check fuel level.
 - Check that your propane tank is properly connected and the valve is open.
 - Inspect the hose of the IronTop™ Grill's LP tank before each use. If there is evidence of abrasion, wear, cuts, or leaks, the hose must be replaced prior to operation.
2. Before using the IronTop™ Grill, make sure it is correctly assembled with all parts present, including the following:
 - IronTop™ Grill cooktop
 - Propane tank
3. Make sure the IronTop™ Grill is at least 20 in. (50.8 cm) away from combustibles (see page 2).
4. Make sure the IronTop™ Grill is level before cooking.
5. Always keep the IronTop™ Grill lid open when preheating and cooking. Make sure to always open and close lid with care.

GENERAL COOKING It's super easy to cook on an IronTop™ Grill. With two to four burners on the cooktop, depending on model, you can cook different foods at different temperatures at the same time. What follows are some tips to get the very best results from your IronTop™ Grill.

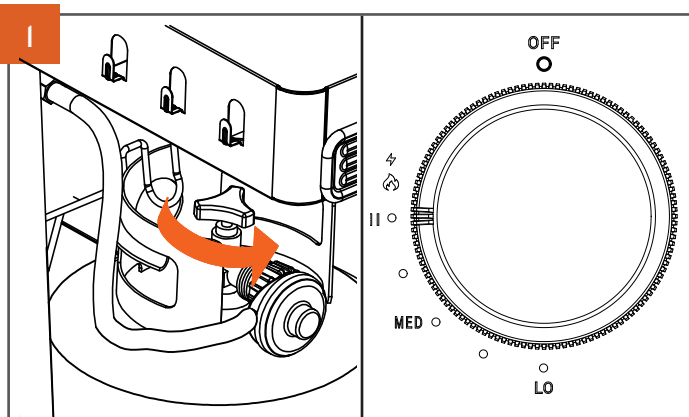

Make sure the propane tank valve has been turned to the fully open position. Press the control knob and rotate slowly (2-3 seconds) to the ignite position (🔥). Turning the knob opens the control valve and activates the igniter. Look at the burner through the flame view opening to confirm that the burner has successfully lit. If the burner did not light, turn the control knob back to the OFF (○) position and repeat until burner ignition is confirmed.

⚠ WARNING Fire Hazard

- If the IronTop™ Grill does not ignite within 5 seconds, turn burner controls OFF (○), wait 5 minutes to allow gas to dissipate, and repeat ignition procedure. If the IronTop™ Grill does not ignite, gas will continue to flow out of burner and could accidentally ignite.

TO MANUALLY LIGHT BURNERS

Burners can be manually lit by using long matches or a long neck utility lighter. Access the burner through the opening located on each side of the grill cavity. Confirm that the burner has successfully lit by looking through the flame openings under the cook surface until you see the flame.

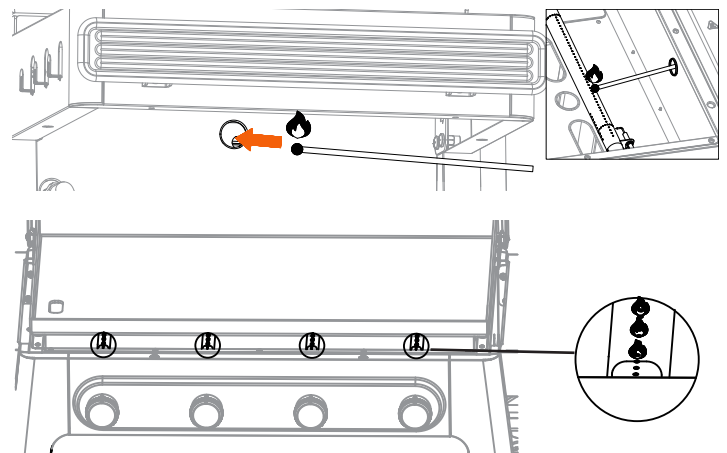

USING YOUR IRONTOP™ GRILL CONTINUED

2

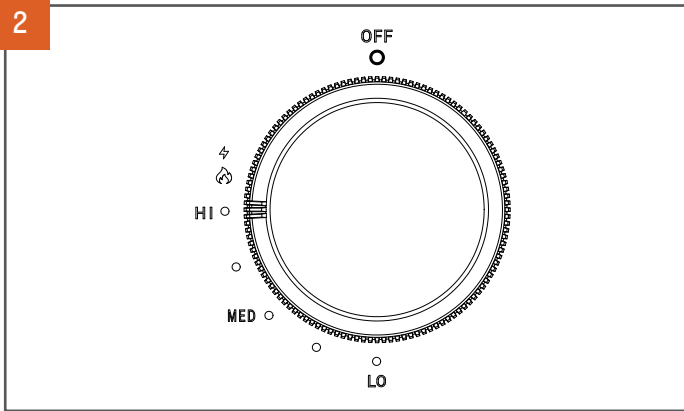

Preheat your IronTop™ Grill on the temperature you want to cook at for up to 15 minutes or until the surface reaches the desired cooking temperature.

⚠ WARNING Risk of Burn Injury

Do not close the lid when preheating or operating the grill, as lid and handle will become very hot. Only close lid to protect grill surface when grill is turned off and is cool to the touch.

3

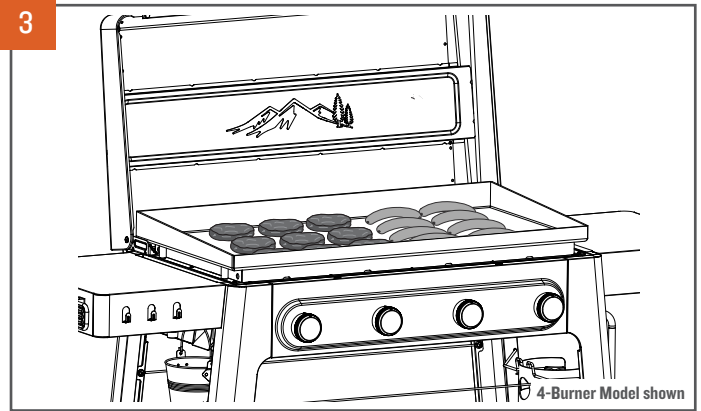

Once preheated, cook away! Be sure to oil the IronTop™ Grill before cooking, no matter the recipe you choose.

PRO TIP: Check your Traeger App for great recipes!

PRO TIPS FOR COOKING ON YOUR IRONTOP™ GRILL

TIP 1: Choose the right kinds of food to cook. Your IronTop™ Grill excels at cooking foods you would normally cook in a sauté pan, wok, or skillet. Though you can cook over low heat, IronTop™ Grills are not the place to fully cook big hunks of meat like pork shoulder or whole chickens—save those for your Traeger® Pellet Grill. IronTop™ Grills are a great place to sear large hunks of meat that are already fully cooked or that will be finished by other methods.

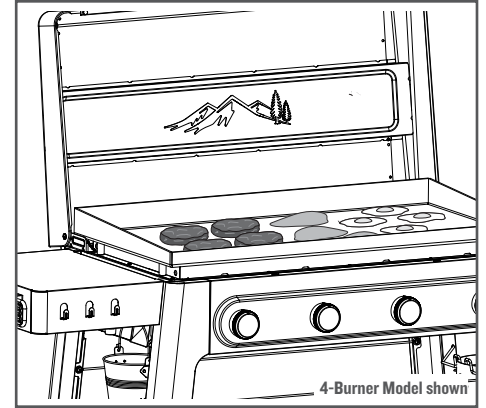
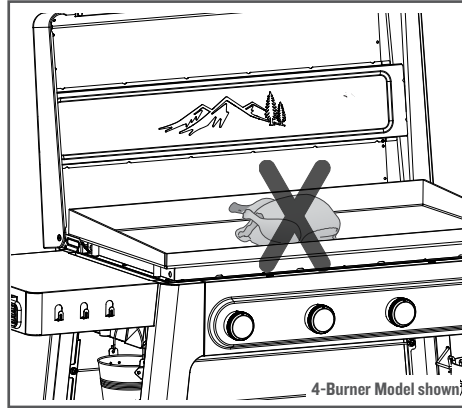

TIP 2: Preparation! Have the food you plan to cook prepped and any tools you need handy. Use one IronTop™ Grill shelf for raw ingredients and utensils that touch them, and the other for cooked food. This helps prevent any cross-contamination as you cook up your feast.

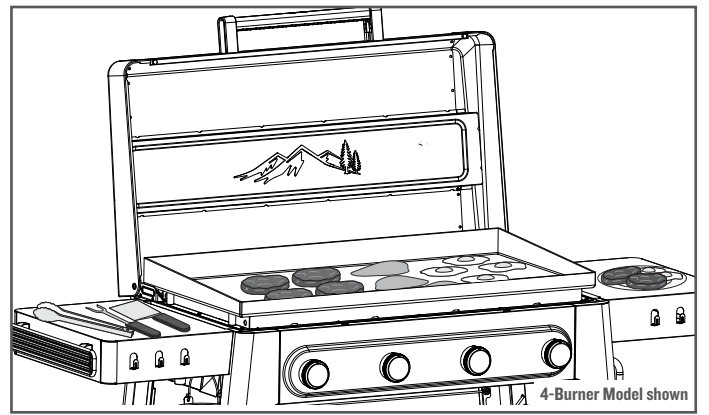

TIP 3: Searing. If you want to give your food a nicely browned crust, be sure to leave space between pieces to encourage a good sear. (If packed too close, foods can steam in their own juice.) Then wait until one side is nicely browned before flipping.

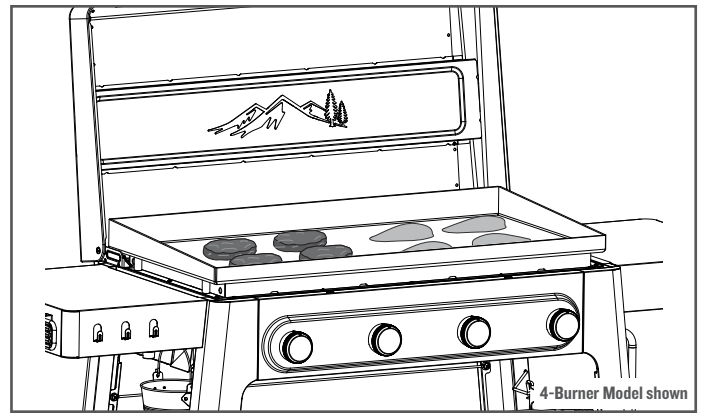

TIP 4: Your IronTop™ Grill has two or four burners, depending on model. You can utilize two to four burners (depending on model) at one time by keeping food warm on some burners, and searing on the others!

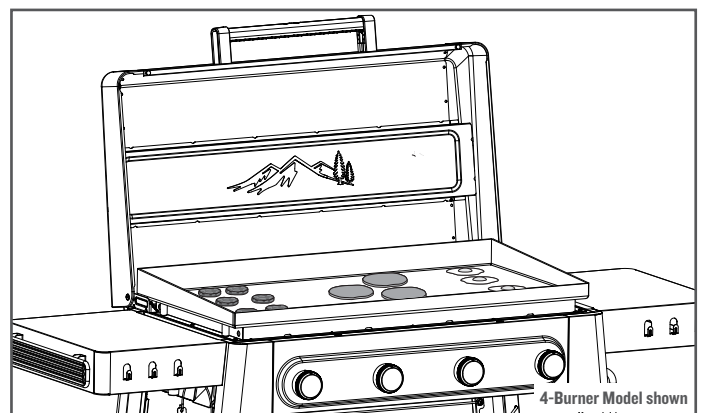

⚠ WARNING Risk of Burn Injury

Do not close the lid when preheating or operating the grill, as lid and handle will become very hot. Only close lid to protect grill surface when grill is turned off and is cool to the touch.

WHEN COOKING IS COMPLETED

CLEAN AND RE-SEASON

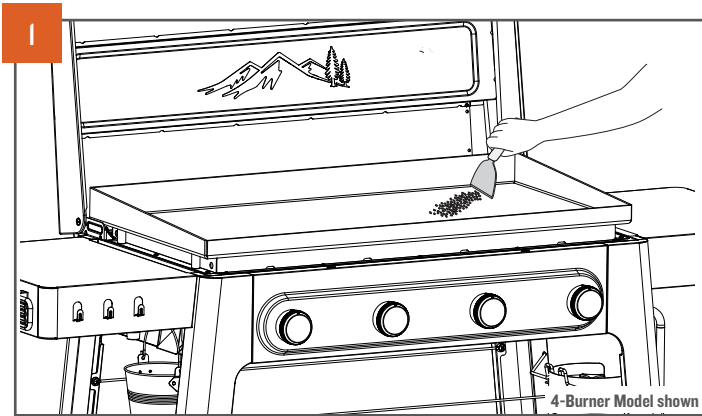

While the IronTop™ Grill is still hot, use a Traeger® IronTop™ Grill Scraper (sold separately) to scrape any cooking residue off the IronTop™ Grill.

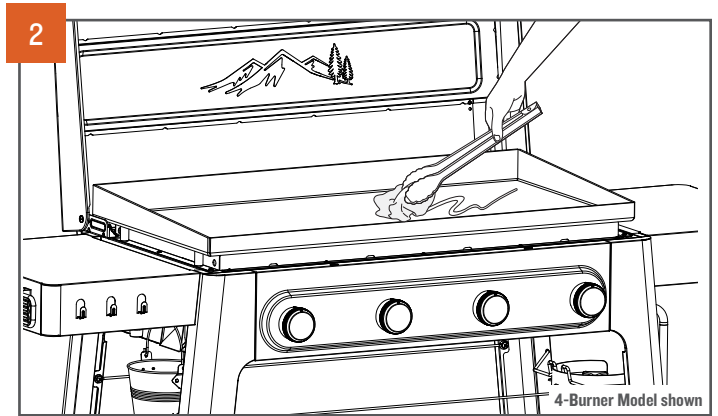

Using tongs clamping a clean towel or paper towel, lightly oil the cooktop with canola oil or another cooking oil with a high smoke point, such as flax or grapeseed. Spread in a thin layer so that it covers the entire cooktop. Heat until the smoking ends, about 10 minutes.

TIP: Be sure to condition the side walls of your cooktop for added protection and rust prevention.

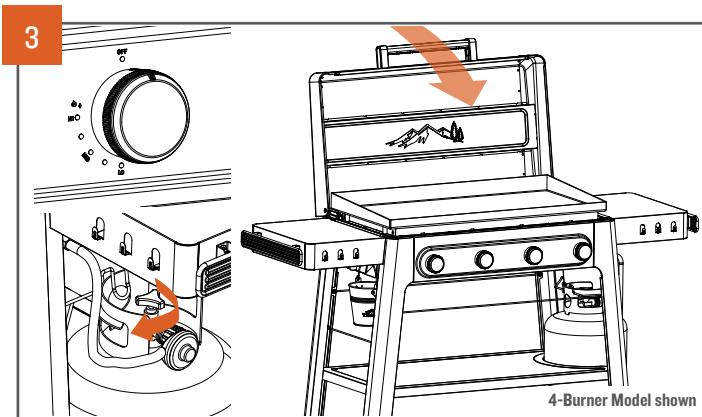

Turn all control knobs to the OFF (○) position, once grill is completely cool close the lid, and turn the propane tank valve closed. Always shut off the propane tank valve completely after every cook.



Once the IronTop™ Grill is completely cool, cover it with a Traeger® IronTop™ Grill Cover (sold separately).

GREASE MANAGEMENT

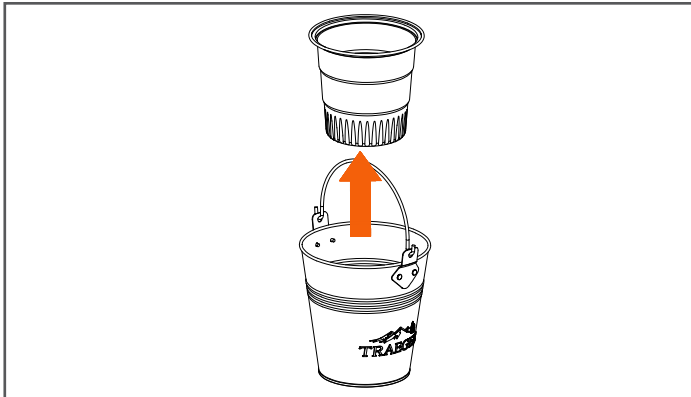

Empty and discard the grease bucket liner. Rehang the grease bucket.

TIP: Ensure the contents of the bucket are cool before discarding.

SHUTTING DOWN YOUR IRONTOP™ GRILL

THE SHUTDOWN PROCESS EXPLAINED

The shutdown cycle is crucial to the success and high-quality performance of your Traeger® IronTop™ Grill.

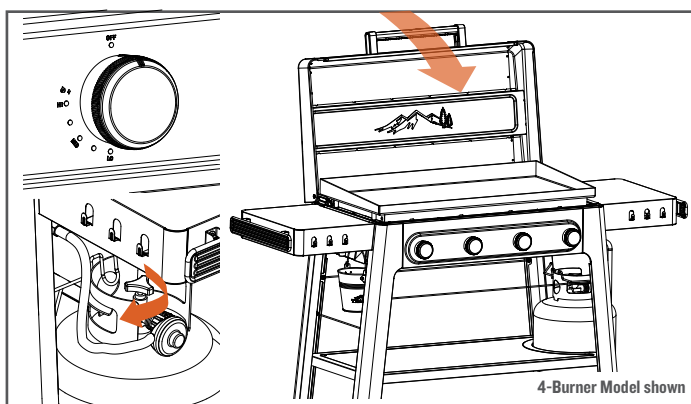

Turn all control knobs to the OFF (○) position, wait until the cooktop is cool, close the lid, and turn the propane tank valve closed.

TIP: Always oil cooktop per instructions in “When Cooking is Completed” prior to shutdown.

MAINTAINING YOUR IRONTOP™ GRILL

CLEANING IRONTOP™ COOKTOP

To clean your IronTop™ Grill, you will need a clean cloth or paper towels, Traeger® Grill Cleaner, water, a Traeger® IronTop™ Grill Scraper (not included), and Traeger® IronTop™ Grill Seasoning & Cast Iron Conditioner or canola oil.

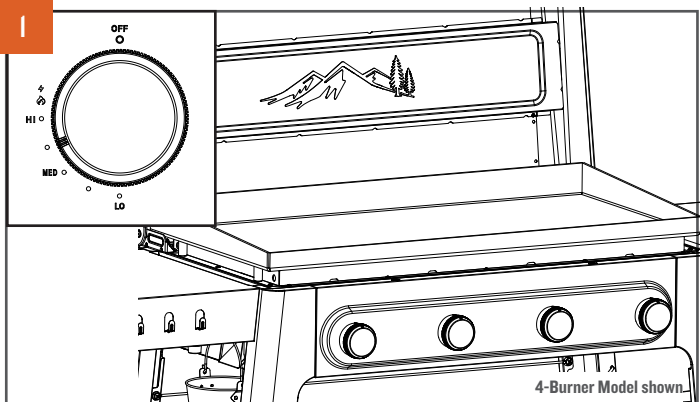

Heat up the cooktop on medium high heat for 10 minutes.

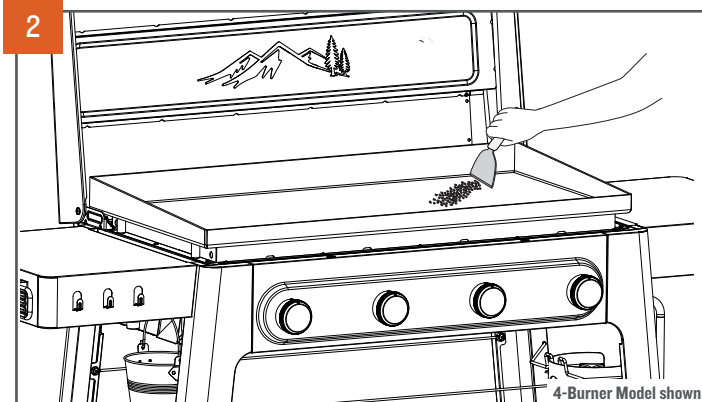

Using a scraper, scrape the entire cooktop clean, directing any bits of food and grease off the IronTop™ Grill. Repeat as needed until all debris has been removed.

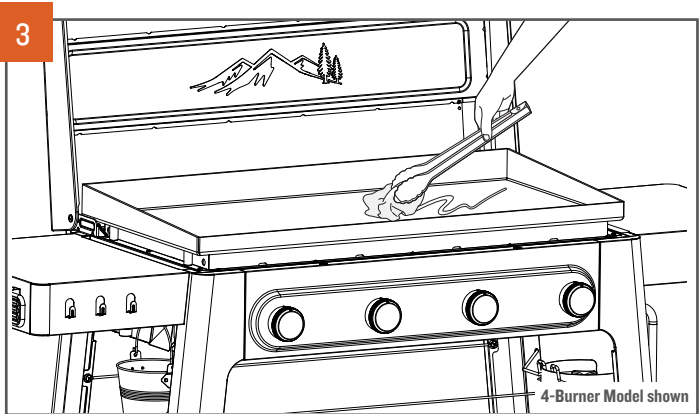

With the IronTop™ Grill still hot, use tongs clasp a clean towel or paper towel to apply a thin layer of Traeger® IronTop™ Grill Seasoning & Cast Iron Conditioner or canola oil. The conditioner must cover the whole cooktop (including the walls and edges). Heat until the smoking ends—about 10 minutes.

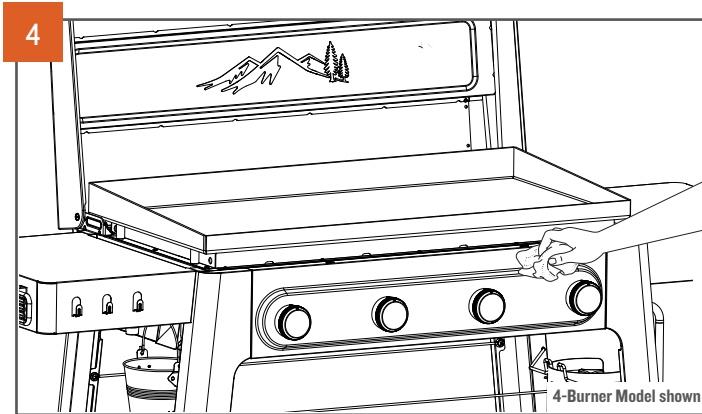

To clean the body of the IronTop™ Grill, turn off the grill and let it cool. Once the IronTop™ Grill is cool, use a cloth or paper towel and Traeger® Grill Cleaner to wipe any messy areas on the IronTop™ Grill body. **DO NOT use Traeger® Grill Cleaner on the cook surface.**

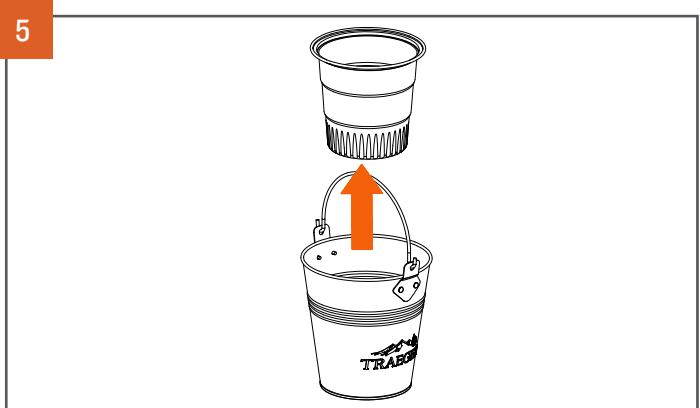

Empty and discard the grease bucket liner. Rehang the grease bucket.

TIP: Ensure the contents of the bucket are cool before discarding.

CHECKING GREASE

Your grease bucket should be checked before and after every cook.

TIPS: Make sure grease has cooled before handling the grease bucket.

CLEANING BURNERS

Sometimes grime and/or insect debris such as webs may accumulate in the burner tube or portholes, especially after periods of non-use or storage. A clogged tube can lead to a fire beneath the appliance or poor performance.

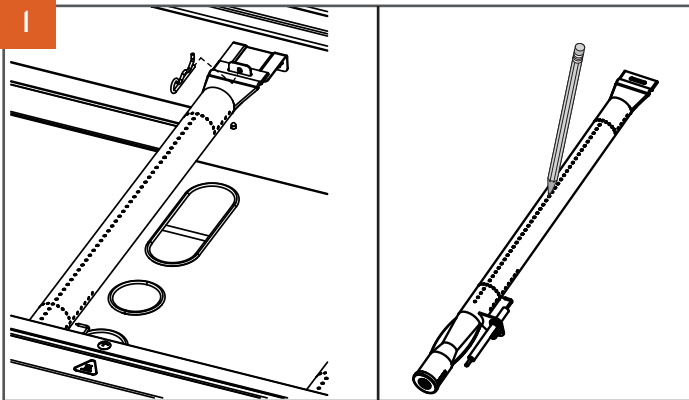

Remove burners from the IronTop™ Grill by detaching the cotter pins on the burner brackets. With burner removed, insert a pen tip or paperclip into the clogged burner inlet hole to clear out any debris that may have accumulated.

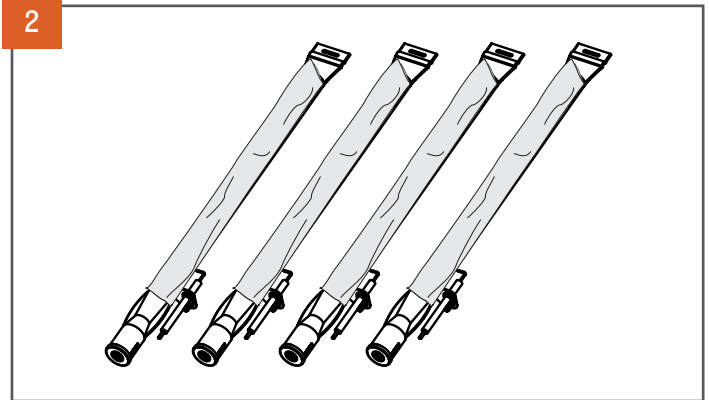

When storing the IronTop™ Grill or before an extended period of non-use, remove the burners and wrap them with aluminum foil to reduce the risk of insects entering the burner holes.

⚠ WARNING Fire Hazard

Always remove all foil before you reattach the burners and use the IronTop™ Grill again.

STORING

Your IronTop™ Grill can be stored in two orientations:

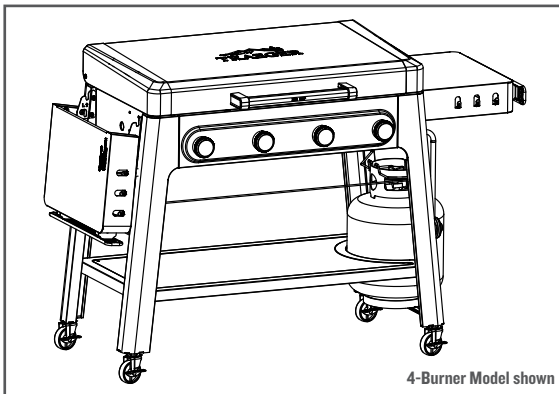

In limited space, fold down the folding shelf.

OR

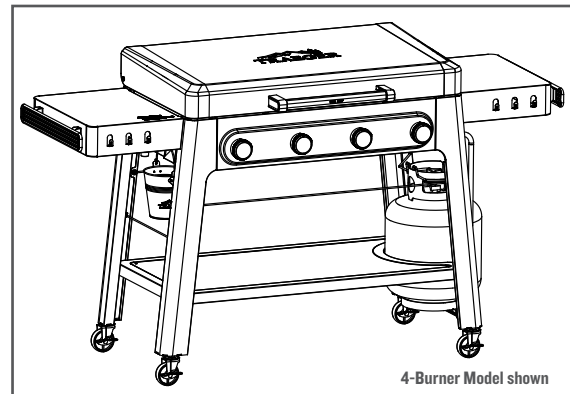

If more space is available, the folding shelf can be left extended.



Use the Traeger® IronTop™ Grill Cover (sold separately) for protection when storing. When using the Traeger® IronTop™ Grill Cover, the shelf must be folded down.



Reminder: Only close lid to protect grill surface and cover the grill when grill is turned off and is cool to the touch

MAINTAINING YOUR IRONTOP™ GRILL CONTINUED

AVOIDING RUST

A good initial seasoning and post-cook seasonings are crucial for preventing rust; however, if your IronTop™ Grill becomes rusty, follow these steps:

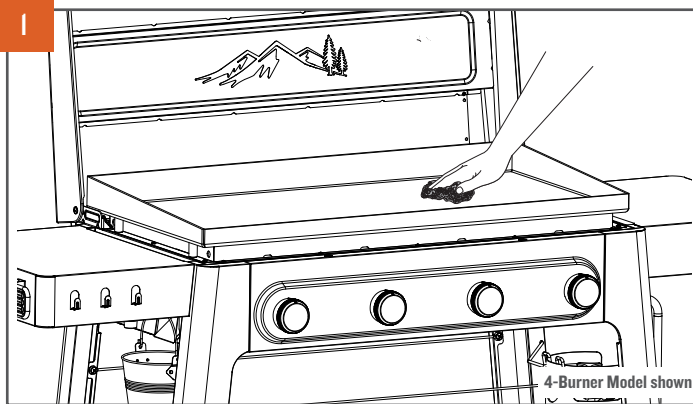

Use a nonabrasive scouring pad and water to remove rust. If rust cannot be removed with the nonabrasive scouring pad, you can use 220 grit sandpaper to remove rust from affected areas.

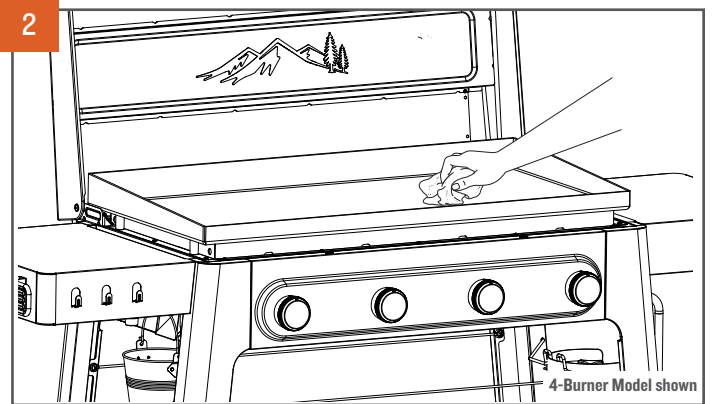

Using water and a cloth, wipe off all of the rust residue. The cooktop should be free of any loose debris created in Step 1. Wipe up all water from this process with a clean, dry towel or cloth. Before performing Step 3, make sure no water is present on the cook surface. Do not attempt to evaporate the excess water by heating the grill.

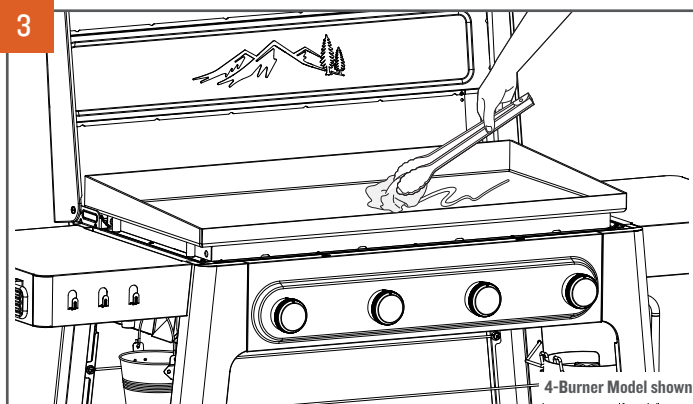

Re-season the cooktop following the seasoning process in “When Cooking is Completed,” or by following the directions on the app.

FREQUENTLY ASKED QUESTIONS

Scan this QR code to take you to Frequently Asked Questions.

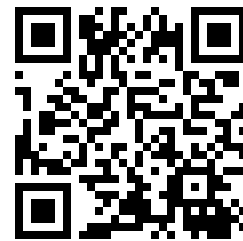

TROUBLESHOOTING

If your IronTop™ Grill is not igniting, check to see if:

1. Your propane tank valve has been turned on (is fully open).
2. There is a good connection between the regulator hose and the propane tank (hand tight).
3. There is a consistent spark from the igniter after turning the knob. Check by removing the cooktop.

If the IronTop™ Grill is not extinguishing:

Check the control knobs to make sure they are in the OFF (○) position and can move freely (when pressed in, they should pop back out).

If your burners are putting out low or uneven flames, there are several possible causes:

1. The regulator safety feature has been tripped (see below).
2. Empty or low propane tank fuel level. As the level of liquid propane in your tank gets low, the burners will still operate but with low or uneven flame height. Replace or refill the propane tank to resolve.
3. The propane tank valve is not opened sufficiently.
4. The regulator hose is not fully attached to the tank valve.
5. A bend or kink in the regulator hose is restricting flow.
6. There may be obstructions in the burner tubes.

If the regulator safety feature is tripped:

Your grill regulator is equipped with a safety feature that is designed to limit the flow of propane if the flow through the regulator is higher than normal. However, it is possible that it may trip from normal usage. Gas flow may also be stopped, making it impossible to light the burners. If you suspect your regulator safety feature has tripped, do the following:

1. Ensure that grill control knobs and propane tank valves are off, and in the closed position.
2. Inspect the hose and manifold for leaks, and ensure that the connections between the manifold and regulator are not loose.
3. Detach the regulator from the propane tank.
4. Turn control knobs to high for 2 minutes.
5. Turn control knobs to OFF (○).

OPERATING TIPS

1. Always keep the lid open during preheating and cooking.
2. Always take into account the type of food you are cooking:
 - Thin foods need high heat and shorter cook times, while thicker foods need low heat and longer cook times.
 - Vegetables take longer to cook than meats at the same cooking temperatures.
 - Always check that the internal temperature of the meat that you are cooking reaches a safe temperature for eating.
3. Always clean your IronTop™ Grill and re-season it regularly to ensure your cook surface retains its nonstick properties.
 - a. Scrape any leftover food into the grease bucket.
 - b. Apply oil to the IronTop™ Grill in a thin layer.
 - c. Check grease bucket after every cook; clean if necessary.
4. Re-season the IronTop™ Grill after every cook for best performance. After scraping to remove any food particles, apply a thin layer of Traeger® IronTop™ Grill Seasoning & Cast Iron Conditioner and heat it until it stops smoking.
5. Your IronTop™ Grill can be used to warm sauces or melt butter. Put the butter or buffalo sauce in a thin-walled pan in the corner of your IronTop™ Grill to keep it out of the way, with that zone set to medium. You will have melted, saucy additions to spice up your meal.

SERVICE



TRAEGER'S LEGENDARY CUSTOMER SERVICE is the best out there. If you have any questions about your Traeger® IronTop™ Grill or need tips, our seasoned experts have your back. We're here for you 365 days a year, including holidays. For assistance with assembly, installation, safe operation, parts, or general customer service, you can reach us at:

TRAEGER'S CUSTOMER SERVICE

Please visit: traeger.com/support
Phone: US/CA: 1-800-TRAEGER 6:00 a.m. – 10:00 p.m. MT
Website: traeger.com
Address: TRAEGER PELLETT GRILLS LLC
533 South 400 West
Salt Lake City, UT 84101

TRAEGER'S CUSTOMER SERVICE IS JUST A SCAN AWAY

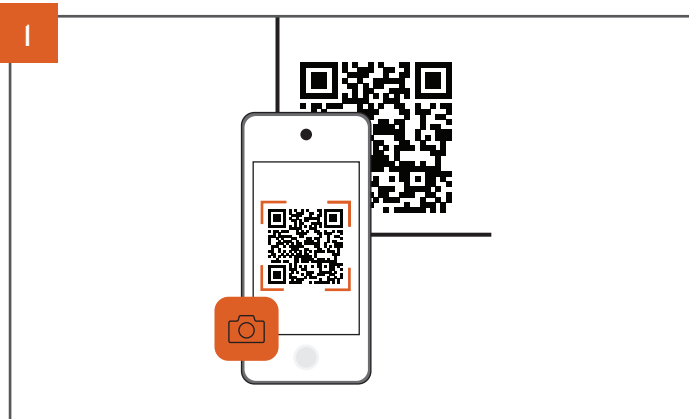

Open the camera on your phone and point it at the QR code.

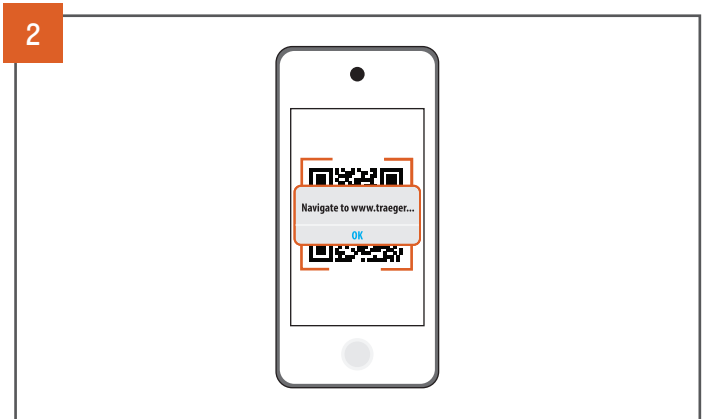

Wait for the camera to register and tap the notification or banner when it appears on your screen.

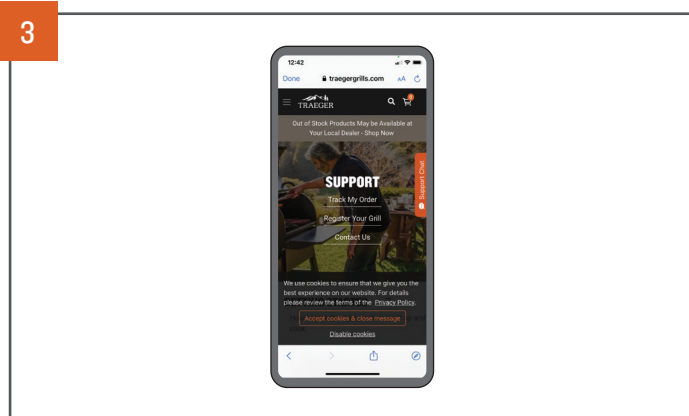

Information related to the code will automatically load.

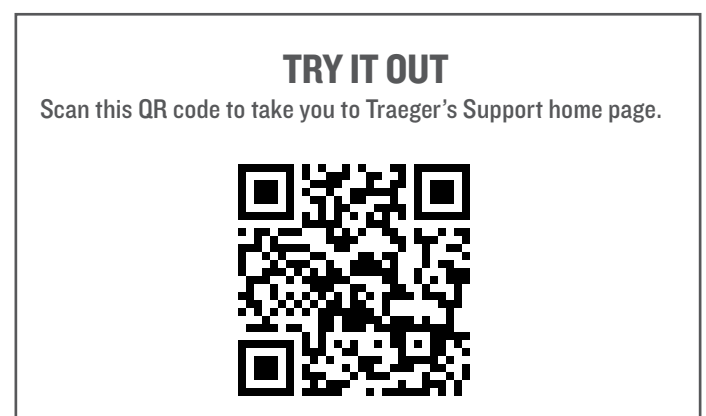

NOTES

TRAEGER® IRONTOP™ GRILL WARRANTY



3-YEAR LIMITED WARRANTY

Traeger Pellet Grills LLC warrants this Traeger® IronTop™ Grill or the components, coverage, and warranty period listed in the table below under normal use and proper maintenance. This warranty gives you specific legal rights, and you may also have other rights which may vary among states and provinces. The warranty period starts from the date of original purchase from traeger.com or a Traeger authorized dealer. A list of Traeger authorized dealers is available at <https://www.traeger.com/dealers> (together each an “Authorized Seller”). The warranty period and coverage for the replacement parts shall be as follows:

Warranty Periods and Coverage		
Components	Warranty Period	Coverage
Body, Legs	3 Years	Will not rust through
IronTop™ Cooktop	1 Year	Material and Manufacturing Defects
Burners	3 Years	Material and Manufacturing Defects

Traeger's entire liability and your exclusive remedy shall be replacement of the defective parts of your Traeger® IronTop™ Grill, if any. Original part(s) approved for return by Traeger's Customer Service must be returned prepaid. Traeger may replace defective parts with new or refurbished parts, at Traeger's sole discretion on an as available basis within ninety days. Without limiting the exclusions stated above, there is not warranty coverage for: (i) paint damage caused by grease fires, (ii) UV exposure, (iii) normal wear and tear; and (iv) warping of the IronTop™ Grill surface.

Traeger® IronTop™ Grills are designed to be modular for simple repair by regular users. Traeger's entire obligation under this warranty shall be to provide you with replacement of any defective parts and to provide you with instructions on how to make the replacement yourself. Traeger may replace defective parts with new or refurbished parts. Traeger reserves the right to inspect any IronTop™ Grill (shipping paid by Traeger) and to analyze any usage information including, without limitation, any digital connected grill data (to the extent covered by our data protection policy). To validate and process a warranty claim Traeger may require that you provide reasonable evidence of your issue, including participating in video chats, phone conversations, providing photos, and providing other relevant information. Labor charges connected with the replacement of defective parts and freight charges to ship parts shall be paid at your expense.

The limitations in the following paragraph do not apply to residents of Quebec to whom the Quebec Consumer Protection Act applies.

FOR GREATER CERTAINTY AND TO FULLEST EXTENT PERMITTED BY LAW, TRAEGER PELLETT GRILLS LLC SHALL NOT BE LIABLE UNDER THIS OR ANY IMPLIED WARRANTY FOR INCIDENTAL, CONSEQUENTIAL DAMAGES, INDIRECT, SPECIAL, LOSS OF DATA, EXEMPLARY, PUNITIVE OR ENHANCED DAMAGES, LOST PROFITS OR REVENUES OR DIMINUTION IN VALUE ARISING OUT OF OR RELATING TO YOUR USE OF YOUR IRONTOP™ GRILL, REGARDLESS OF (A) WHETHER SUCH DAMAGES WERE FORESEEABLE, (B) WHETHER OR NOT TRAEGER WAS ADVISED OF THE POSSIBILITY OF SUCH DAMAGES AND (C) THE LEGAL OR EQUITABLE THEORY (CONTRACT, TORT, OR OTHERWISE) UPON WHICH THE CLAIM IS BASED, AND NOTWITHSTANDING THE FAILURE OF ANY AGREED OR OTHER REMEDY OF ITS ESSENTIAL PURPOSE. THIS WARRANTY GIVES THE RETAIL CUSTOMER SPECIFIC LEGAL RIGHTS AND THE CUSTOMER MAY HAVE OTHER RIGHTS WHICH VARY AMONG STATES AND PROVINCES. BOTH YOU AND TRAEGER INTEND FOR THIS WARRANTY TO BE YOUR EXCLUSIVE REMEDY FOR A DEFECTIVE IRONTOP™ GRILL.

This warranty shall be void if: (i) the IronTop™ Grill is not assembled or operated in accordance with Traeger's operating instructions provided with this grill; (ii) the IronTop™ Grill is not purchased from an Authorized Seller; (iii) the IronTop™ Grill is resold or traded to another owner; (iv) there has been use of any incompatible third party components; (v) the IronTop™ Grill has been used in a commercial or food service application; (vi) the user has allowed the IronTop™ Grill to become damaged, abused, or otherwise failed to maintain the IronTop™ Grill in accordance with Traeger's operating instructions; or (vii) there has been any unapproved modification of this IronTop™ Grill.

Please note that because Traeger is unable to oversee or control the quality of its products sold by unauthorized sellers, Traeger's warranty extends only to products purchased from an Authorized Seller.

To process a warranty claim, contact Traeger's customer service at the phone number or address listed above. Traeger requires proof of your date of purchase from an Authorized Seller. You should retain your sales slip or invoice along with this manual with your valuable documents.

Customers outside of the United States and Canada should note that NOT all warranty policies stated herein are consistent globally. Customers should contact the local distributor in their current country from the list at International Support for instructions regarding warranty claims specific to that country. The process described herein will not work for international warranty requests.

ADDITIONAL IMPORTANT WARRANTY INFORMATION

- We are not responsible for items lost in transit. For this reason, we highly recommend getting a tracking number or delivery confirmation when shipping your package.
- The product you send to us becomes the possession of Traeger and will not be returned to you.

Traeger will determine if your warranty claim is covered under this warranty policy at Traeger's sole and complete discretion, and failure to follow the required procedures may void your warranty claim. This warranty gives you specific legal rights, and you may also have other rights which vary among states, provinces, and countries.





WELCOME
TO THE
TRAEGERHOOD™

FOLLOW US @TRAEGERGRILLS



Traeger Pellet Grills LLC
533 South 400 West
Salt Lake City, UT 84101

traeger.com

© 2026 Traeger Pellet Grills LLC. All Rights Reserved.

Patent: www.traeger.com/patents