

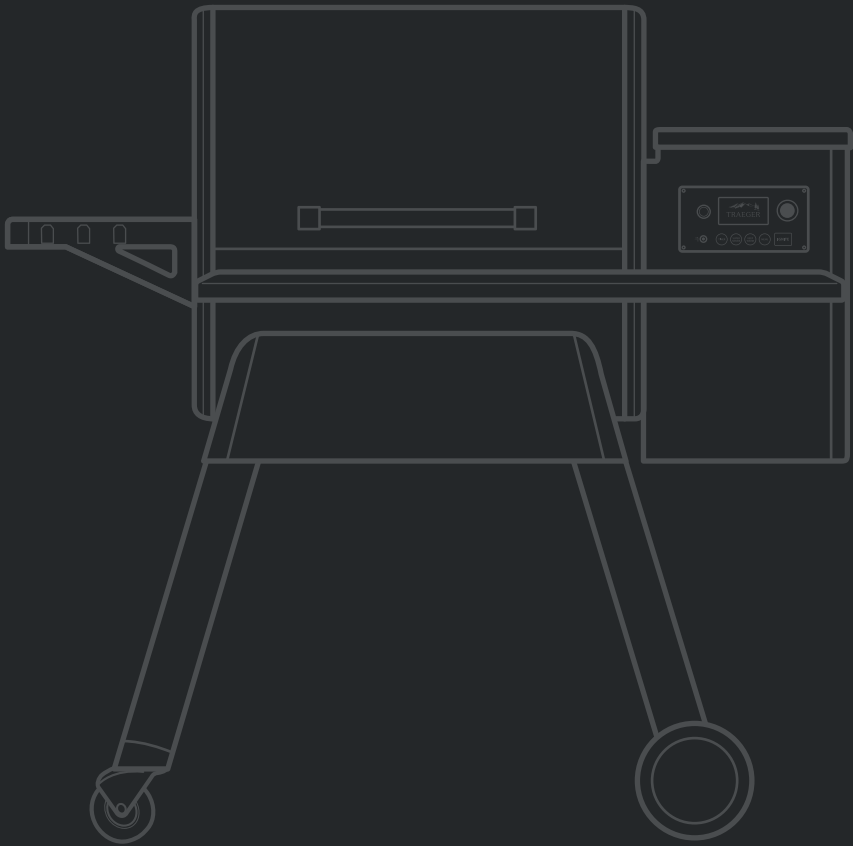

TIMBERLINE

— 850/1300 —

ASSEMBLY GUIDE



Please read this entire manual before installation and use of this pellet fuel-burning appliance. Failure to follow these instructions could result in property damage, bodily injury, or even death. Contact your local building or fire officials about restrictions and installation inspection requirements in your area.

A MAJOR CAUSE OF FIRES IS FAILURE TO MAINTAIN REQUIRED CLEARANCES (AIR SPACES) BETWEEN COMBUSTIBLE MATERIALS. IT IS OF UTMOST IMPORTANCE THAT THIS PRODUCT BE INSTALLED ONLY IN ACCORDANCE WITH THESE INSTRUCTIONS. SAVE THESE INSTRUCTIONS.

WARNING!

MANY PARTS OF THE GRILL WILL BECOME VERY HOT DURING OPERATION. CARE MUST BE TAKEN TO AVOID BURNS, BOTH DURING OPERATION AND AFTERWARDS, WHILE THE GRILL IS STILL HOT.

Never leave the grill unattended when young children are present.

Never move the grill when it is operating.

Let the grill cool completely before moving or attempting to transport.

TFB85WLE/WLEC
TFBO1WLE/WLEC

TRAEGER PELLET GRILLS LLC
1215 E. WILMINGTON AVE
SALT LAKE CITY, UT 84106

TRAEGERGRILLS.COM

PLACING YOUR GRILL



WARNING!

- When operating this grill under overhead combustibles, a **MINIMUM** of 40 inches (102 cm) is required.
- When operating this grill, maintain a **MINIMUM** distance of 18 inches (45.7 cm) from the grill to combustibles.

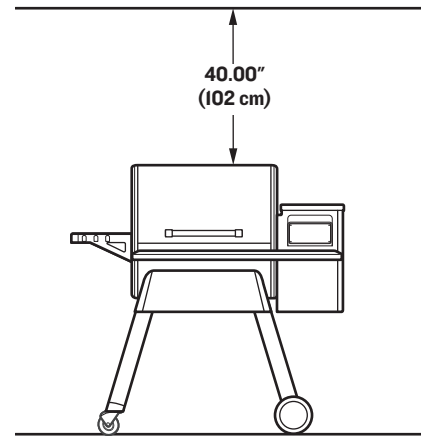
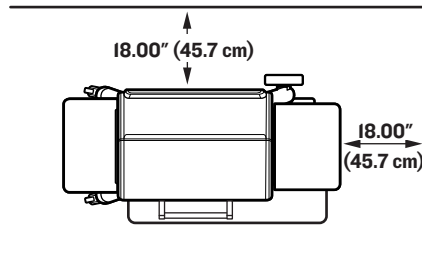

GRILL COMPONENTS

HARDWARE

STEP 1 (LEGS)

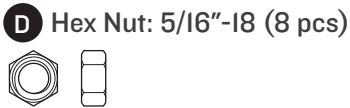
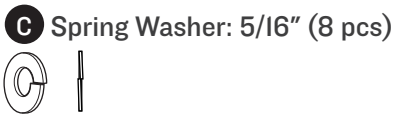
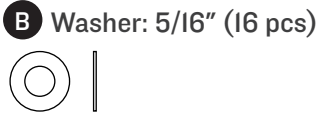
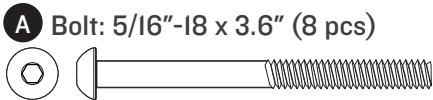

STEP 2 (LEG BRACES)

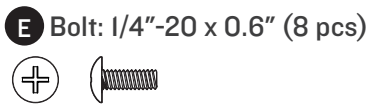

STEP 3 (SIDE SHELF)

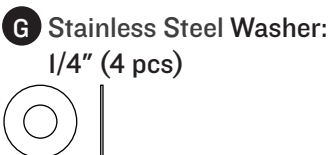
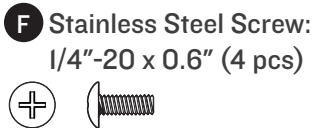

STEP 4 (FRONT SHELF)

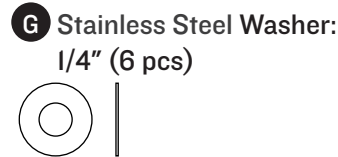
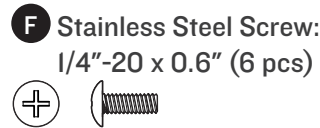

STEP 5 (HANDLE)

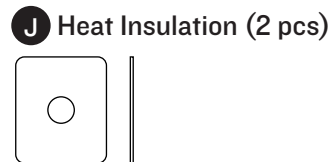
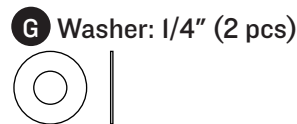
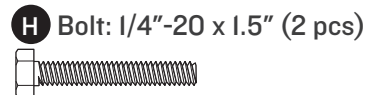

TOOLS INCLUDED

Hex Key (1 pc)



Wrench (2 pcs) Screwdriver (1 pc)

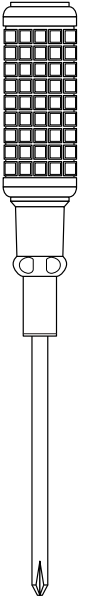

RECOMMENDED TOOLS (not included)

Box Cutter or Scissors

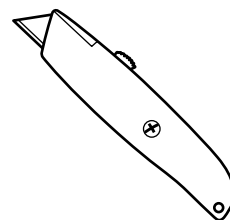

Optional Equipment:

6-Pack



PARTS LIST*

NOTE: Numbers shown are for diagram reference only. Actual parts may be labeled differently.

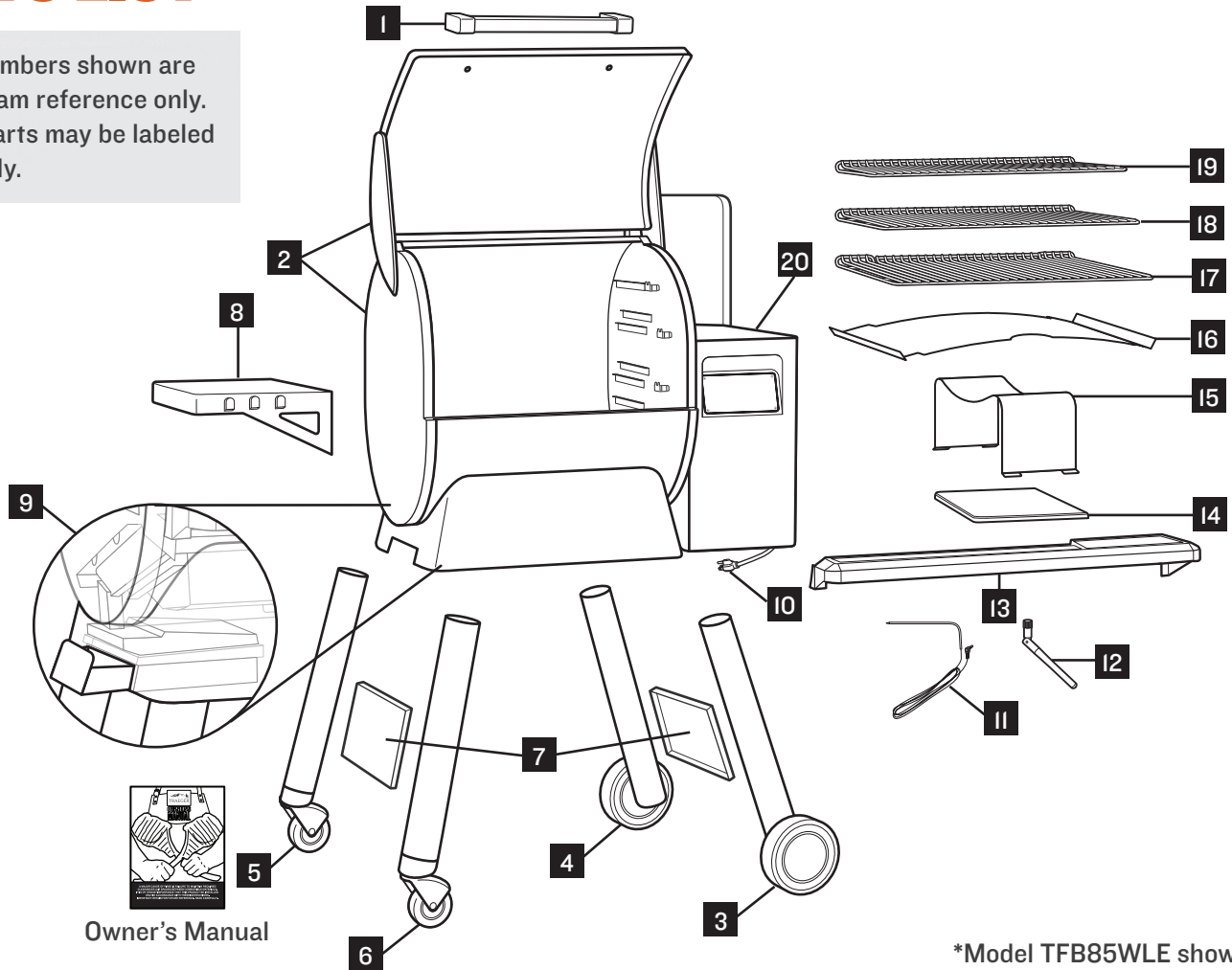

*Model TFB85WLE shown

PART NO.	DESCRIPTION
1	Grill Door Handle
2	Grill Body and Door
3 4	All-Terrain Wheel Legs
5 6	Locking-Caster Legs
7	Leg Braces
8	Side Shelf
9	Grease Management System
10	Power Cord
11	Meat Probe

PART NO.	DESCRIPTION
12	Wi-Fi Antenna
13	Front Shelf
14	Cutting Board
15	Heat Baffle
16	Grease Drip Tray
17	Bottom Grill Grate
18	Middle Grill Grate
19	Top Grill Grate
20	Pellet Hopper Assembly

GRAB THE 6-PACK, GET THE TOOLS, CUE THE RADIO
**IT'S ALMOST
 TRAEGER'ING TIME**

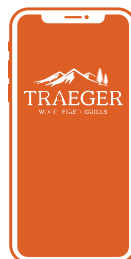

**UNLOCK THE FULL POWER OF YOUR GRILL
 WITH THE TRAEGER APP**

ASSEMBLY INSTRUCTIONS, INITIAL FIRING TIPS, FAQs, PLUS USE AND CARE INFORMATION ARE ALL AVAILABLE THROUGH THE APP.
**DOWNLOAD THE TRAEGER APP OR GO TO
WWW.TRAEGERGRILLS.COM/APP TO LEARN MORE**

READ ALL INSTRUCTIONS BEFORE INSTALLING AND USING THE GRILL

Traeger'ing is more fun with friends! (No, really, you will need two people to lift the grill.)

BEFORE ASSEMBLY: REMOVE GRILL PARTS AND PACKAGING

NOTE: You should assemble grill on a clean, flat surface, as you will need to lay it on its back at times during assembly.

THIS WILL REQUIRE TWO PEOPLE.

NOTE: We recommend you use the packaging material to prop up the grill to make attaching the legs easier.

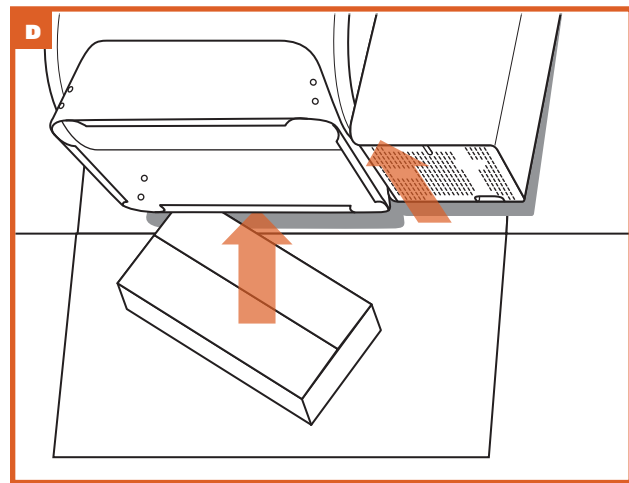
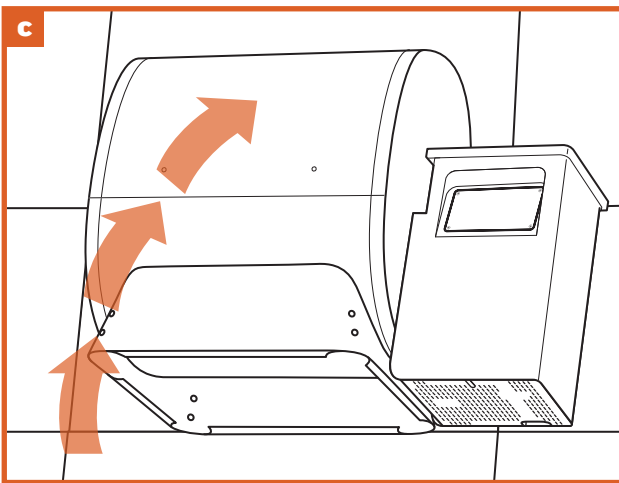
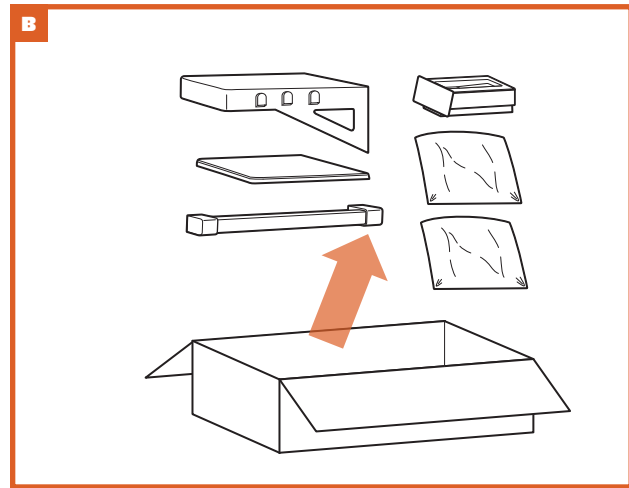
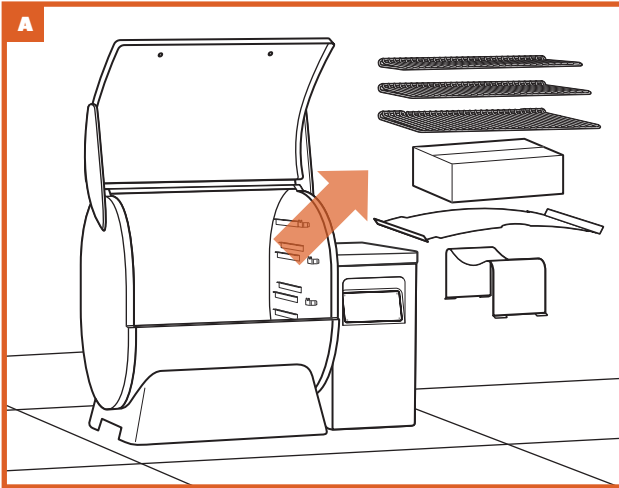

I INSTALL LEGS

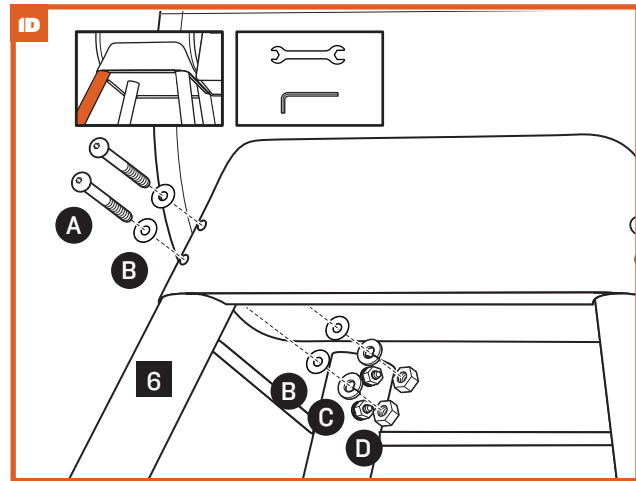
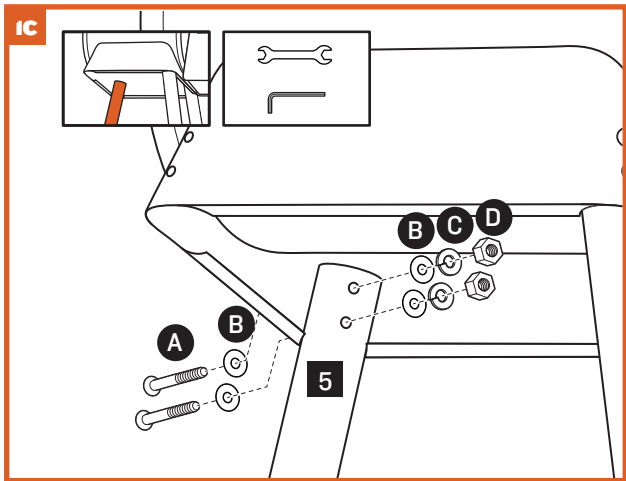
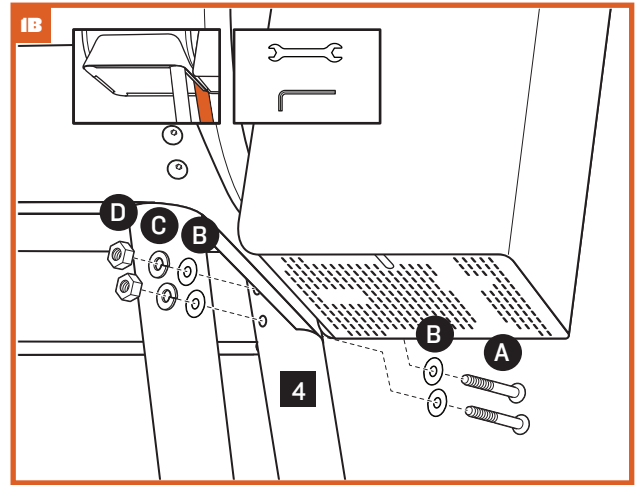
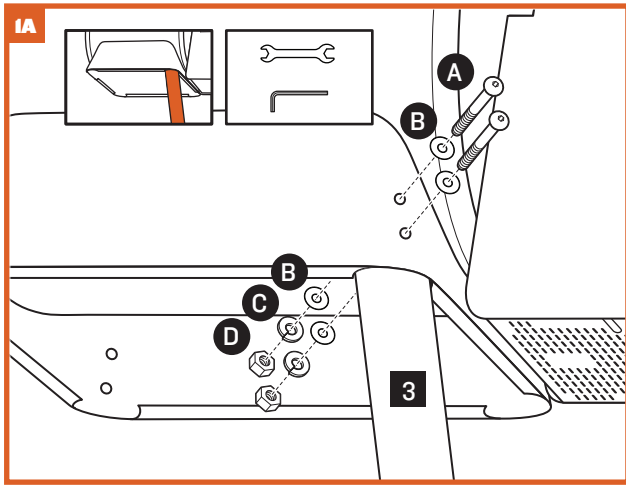
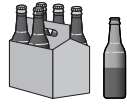

2 INSTALL LEG BRACES

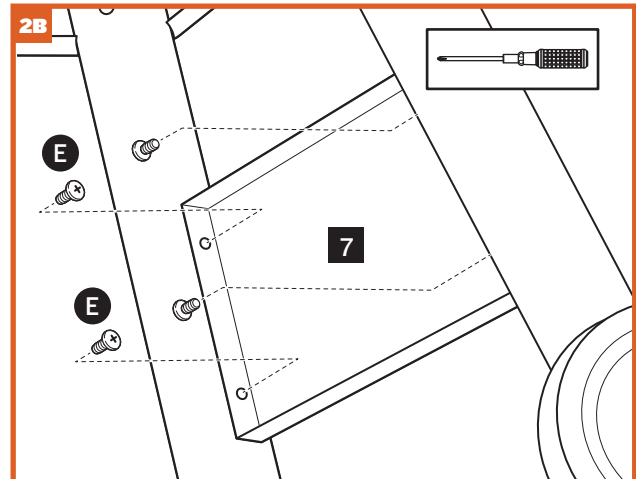
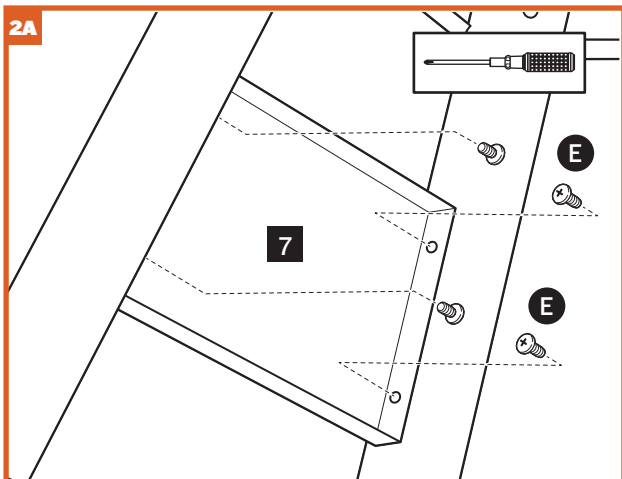
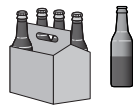

3

INSTALL WI-FI ANTENNA, POWER CORD, AND SIDE SHELF

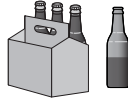

THIS WILL REQUIRE TWO PEOPLE.

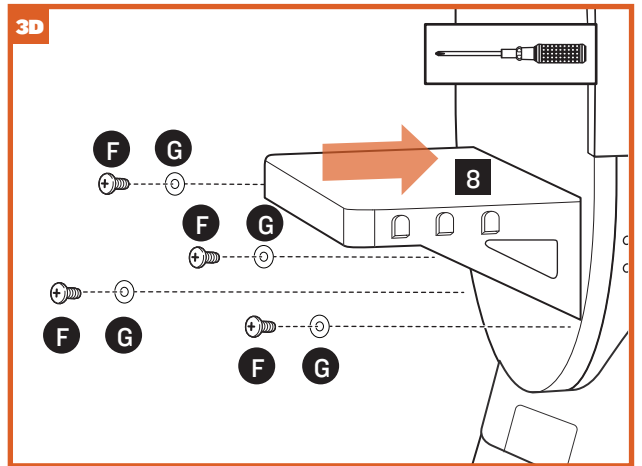
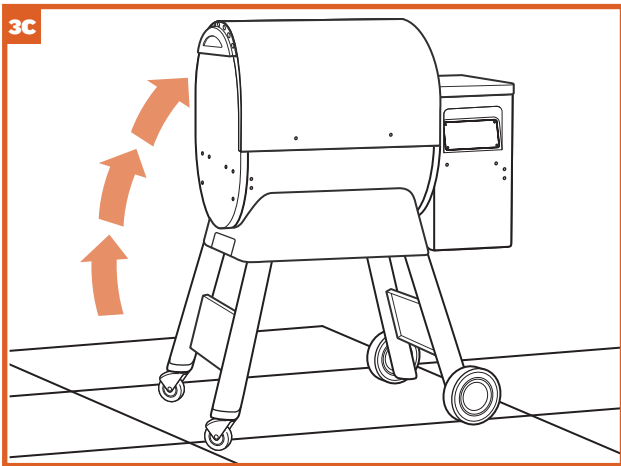
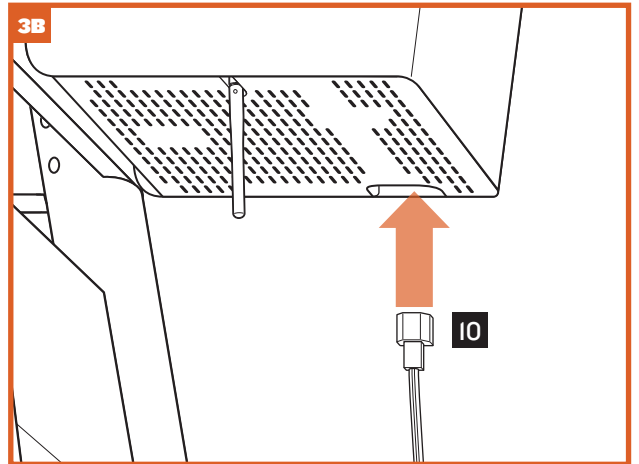
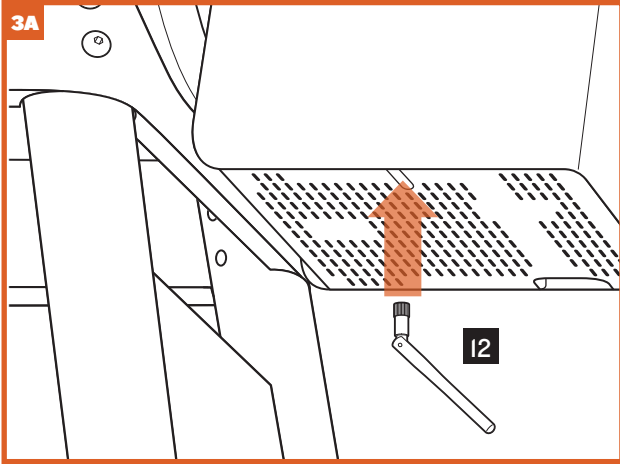

4 INSTALL FRONT SHELF

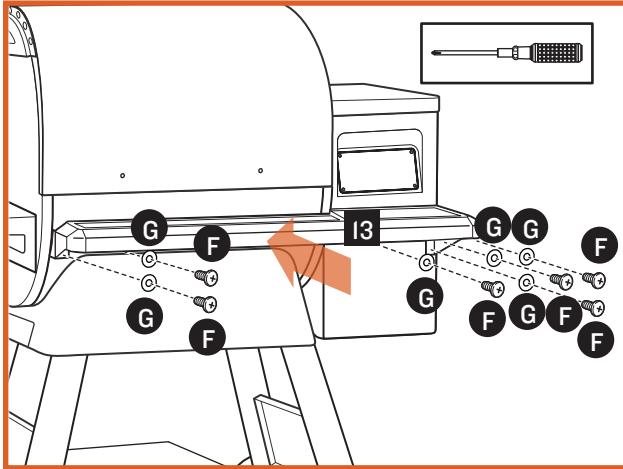
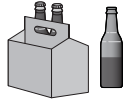

5 INSTALL HANDLE AND GREASE PAN WITH LINER

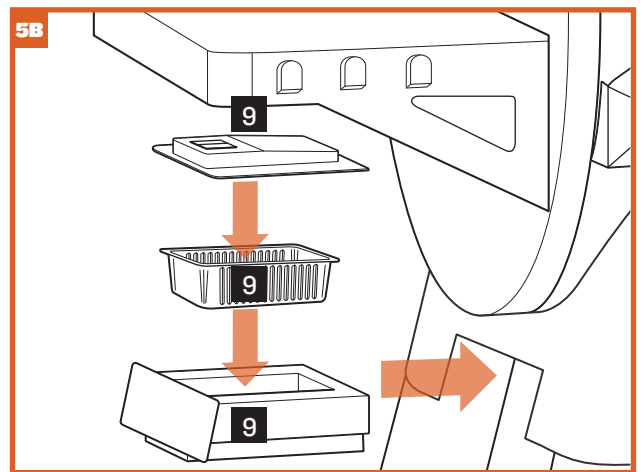
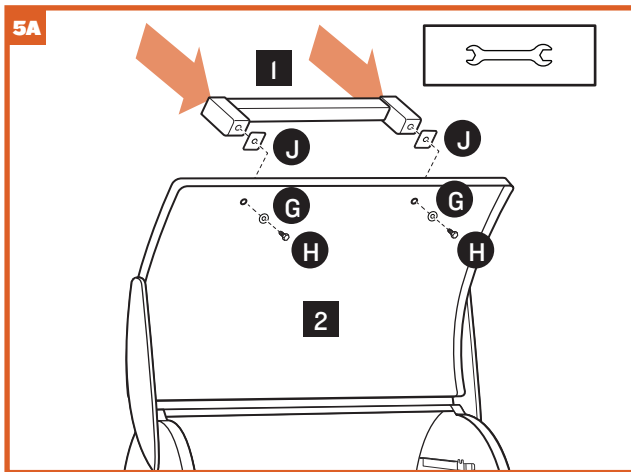
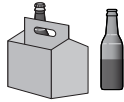

6

ASSEMBLE INTERNAL PARTS

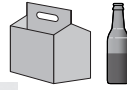

NOTE: Remove all remaining packaging material from grill parts, main grill body, and pellet hopper.

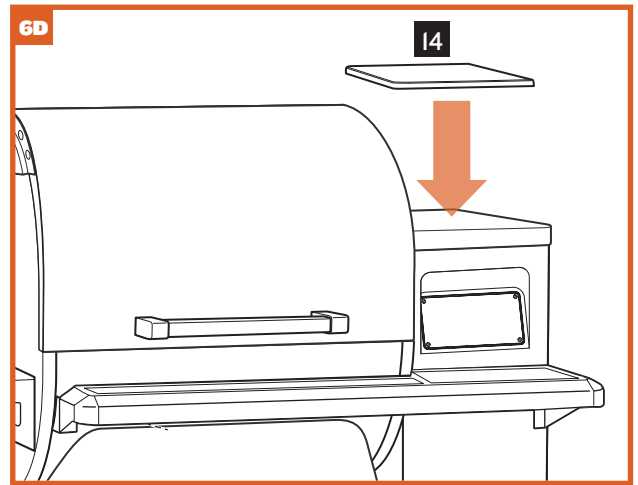
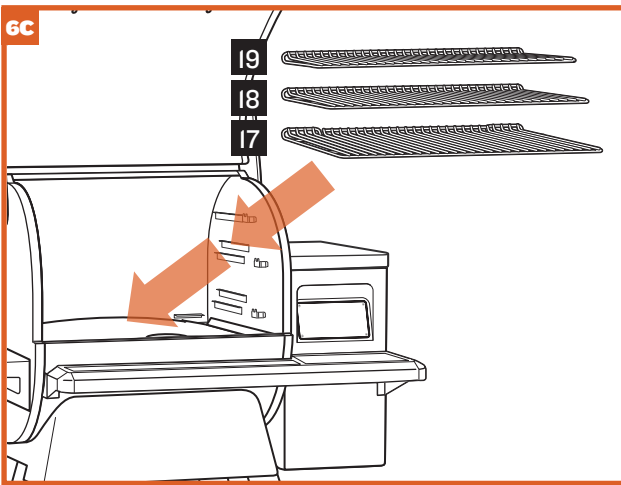
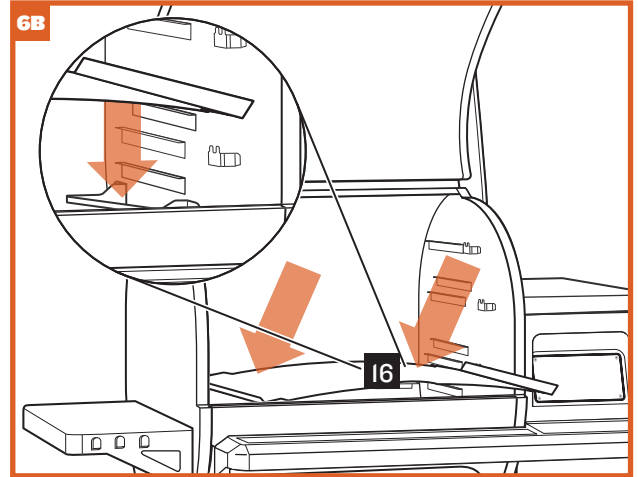
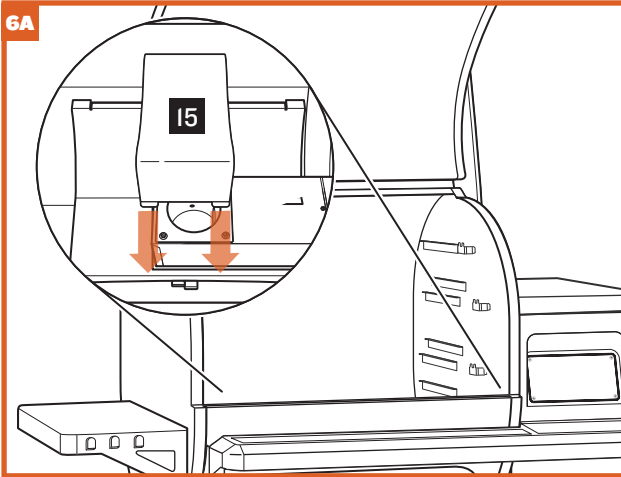

NOTE: Remember to remove protective plastic film from control panel before use.

7

YOU ARE READY TO SEASON YOUR GRILL AND GET TRAEGER'ING!



Refer to your Owner's Manual for operating instructions.

NOTES

NOTES



WELCOME TO THE WOOD FIRED REVOLUTION

GET THE MOST OUT OF YOUR GRILL

WiFIRE gives you the freedom to grill on the go anytime, from anywhere by letting you change temperatures, monitor food temps, and more right from your smart phone. Simply download the Traeger App to connect your grill to your phone and home network. To learn more about WiFIRE, the Traeger App and more ways to connect, go to traegergrills.com/app.

HARDWOOD PELLETS

At Traeger, we're big on taste. That's why we create our own 100% all-natural hardwood pellets, ensuring only the best quality wood is used to flavor your food and burn the most efficiently and reliably. Our pellets are designed exclusively to work with our controller and proprietary Grilling Logic. We can't guarantee the same results from other pellet brands, so we always recommend using our pellets for the optimal experience.

RECIPES

Now to the best part—the food. Let our culinary creations inspire you, from the Traeger Chicken Challenge and baked apple pie to smoked cocktails and jalapeño poppers, find recipes for any occasion through the Traeger App. Plus, with GrillGuide you'll be able to master more recipes thanks to its step-by-step guidance through the entire cook cycle. All of these recipes and more can be found on the Traeger App or at traegergrills.com/recipes.

SAFETY & MAINTENANCE

Regular cleaning of your grill will avoid grease buildup while maintaining peak performance and temperature. Making sure your grill is clean has never been easier thanks to Traeger's lineup of products like our custom Drip Tray and Grease Bucket Liner, as well as our All Natural Cleaner. Remember, your Traeger gets really hot, so always keep your grill at a safe distance from your home or any combustible materials. We recommend keeping at least 18 inches (45.7 cm) on all sides free as well as 40 inches (102 cm) overhead.



**DOWNLOAD THE
TRAEGER APP**



PELLET GUIDE

	GOOD WITH ANYTHING. GREAT WITH:							
	BEEF	CHICKEN	PORK	LAMB	SEAFOOD	BAKED	VEGGIES	WILD GAME
ALDER								
APPLE								
CHERRY								
HICKORY								
MAPLE								
MESQUITE								
OAK								
PECAN								
BIG GAME BLEND								
TURKEY BLEND								
TEXAS BEEF BLEND								
SIGNATURE BLEND								
SUMMER SHANDY BLEND								

INTERNAL TEMPERATURE GUIDE

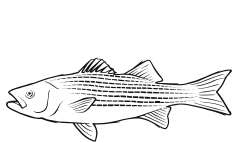

FISH
145°F

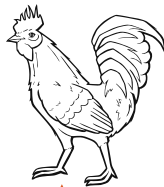

POULTRY
165°F

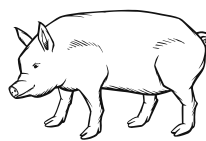

PORK
145°F
PULLED: 205°F

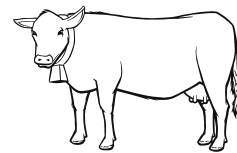

BEEF
RARE: 125°F MED WELL: 155°F
MED RARE: 135°F WELL: 160°F
MED: 145°F BRISKET: 205°F

Download the Traeger App for access to hundreds of free wood-fired recipes, from the main dish to appetizers, desserts, and even some smokin' cocktails. Available on iOS & Android.

Follow Traeger to stay up-to-date on the latest products, enter giveaways, learn tips from our pros, and get a brand new recipe every single day, 365 days a year.



@TRAEGERGRILLS | @TRAEGERRECIPES