



ASSEMBLY GUIDE

WOODRIDGE ELITE WOOD PELLET GRILL



**SCAN FOR
STEP BY STEP
ANIMATED
INSTRUCTIONS**

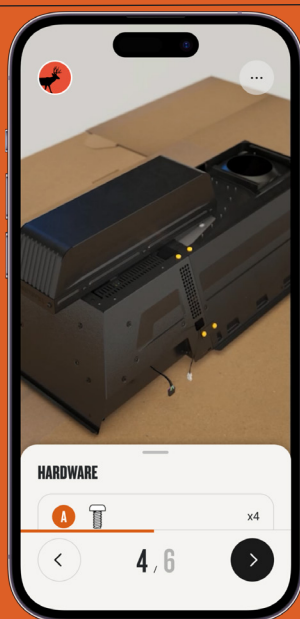

A MAJOR CAUSE OF FIRES IS FAILURE TO MAINTAIN REQUIRED CLEARANCES (AIR SPACES) TO COMBUSTIBLE MATERIALS. IT IS OF UTMOST IMPORTANCE THAT THIS PRODUCT BE INSTALLED ONLY IN ACCORDANCE WITH THESE INSTRUCTIONS.

IMPORTANT: RETAIN FOR FUTURE REFERENCE. READ CAREFULLY.

T18985

©2025 TRAEGER PELLET GRILLS LLC.
ALL RIGHTS RESERVED.

TRAERER PELLET GRILLS LLC

533 SOUTH 400 WEST
SALT LAKE CITY, UT 84101

TRAERER.COM

BEFORE YOU BUILD

PLEASE READ THIS ASSEMBLY GUIDE AND YOUR OWNER'S MANUAL BEFORE INSTALLATION AND USE OF YOUR TRAEGER GRILL. FAILURE TO FOLLOW THE INSTRUCTIONS IN THIS ASSEMBLY GUIDE AND YOUR OWNER'S MANUAL COULD RESULT IN PROPERTY DAMAGE, BODILY INJURY, OR EVEN DEATH.

When using your grill, maintain a MINIMUM distance of 50.8 cm (20 inches) from the grill to any nearby combustibles, including wooden railings, home siding, window frames, furniture, trees, and trash receptacles, etc. Do not install or operate this grill on combustible floors or surfaces, indoors or under a combustible ceiling or overhang. Read the Owner's Manual for additional instructions and warnings.

SETUP SPACE



PRO TIP: Build on the bottom tray of the shipping box to help prevent scratches.

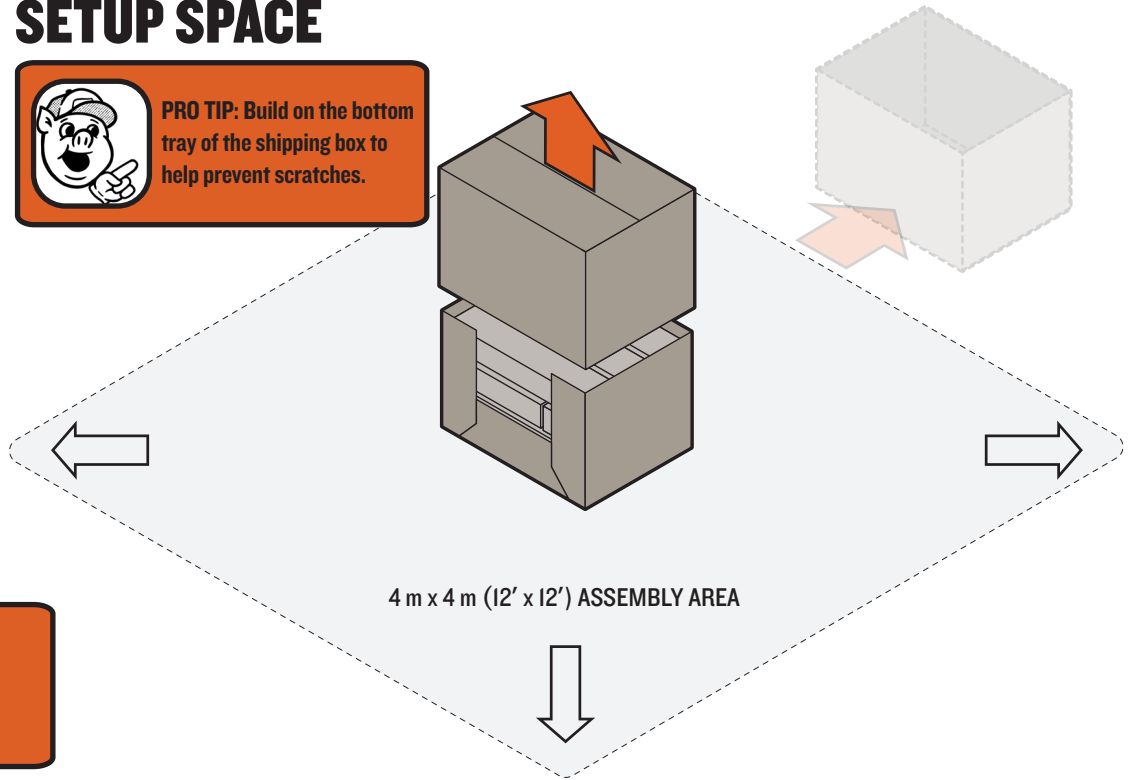

PRO TIP: We recommend assembling your grill with two people.

SETUP

Once all components are unpacked, arrange pieces onto the bottom tray of the shipping box.

GROUP BOXES BY THEIR IDENTIFYING SYMBOLS, SHOWN BELOW:



COMPARTMENTS & LEGS



CABINET & CASTERS



FOLDING SIDE SHELF, BASE, & CONTROLLER



LID & GRILL INTERNALS

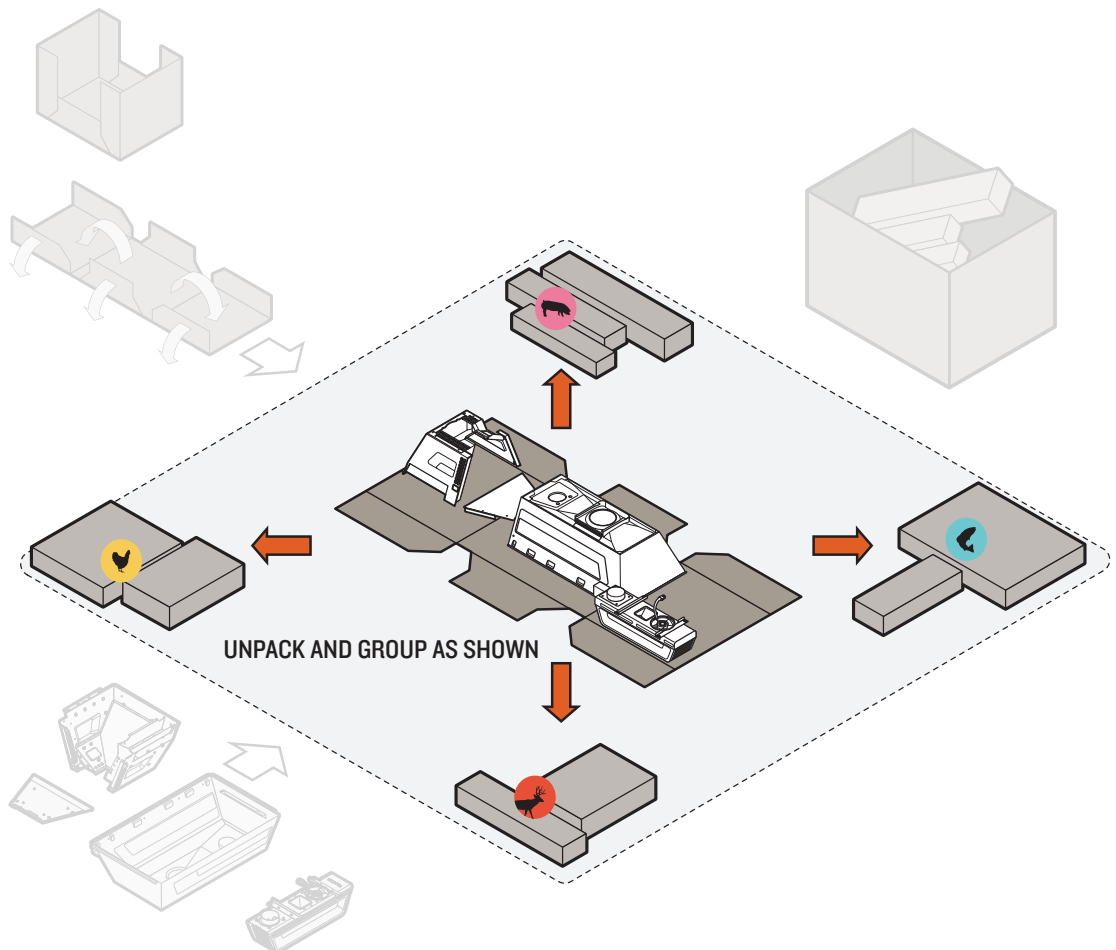



HARDWARE (TOTAL QUANTITIES)

1:1 SCALE

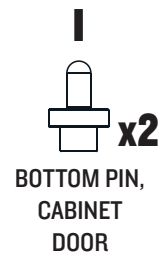
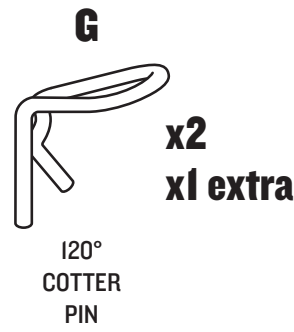
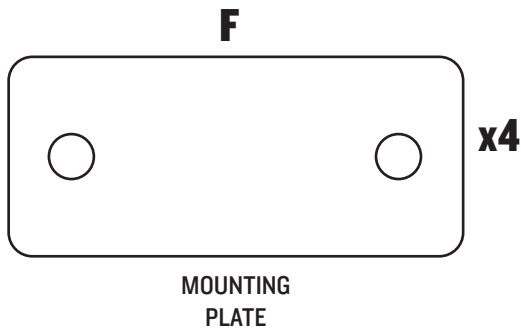
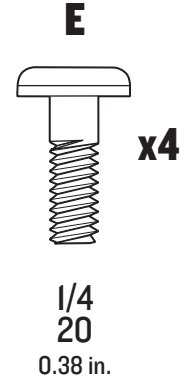
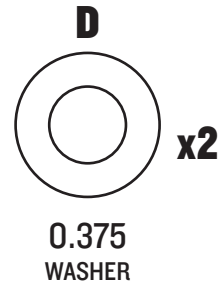
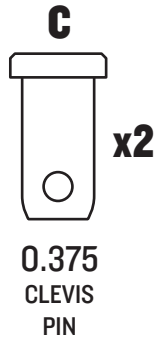
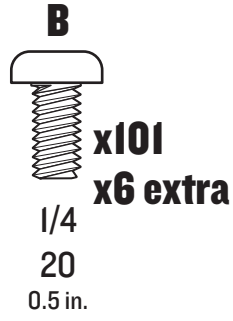
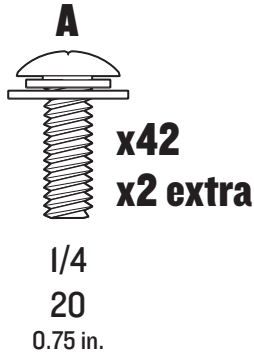



CHAPTERS

CHAPTER 1 – PAGE 5 COMPARTMENTS & LEGS

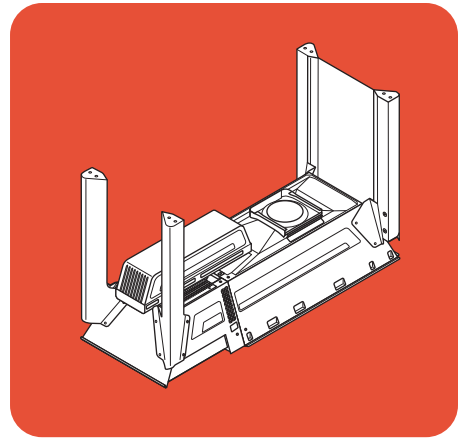

CHAPTER 2 – PAGE 13 CABINET & CASTERS

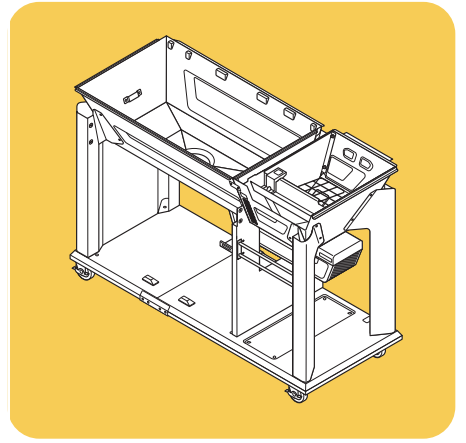

CHAPTER 3 – PAGE 21 FOLDING SIDE SHELF, BASE, & CONTROLLER

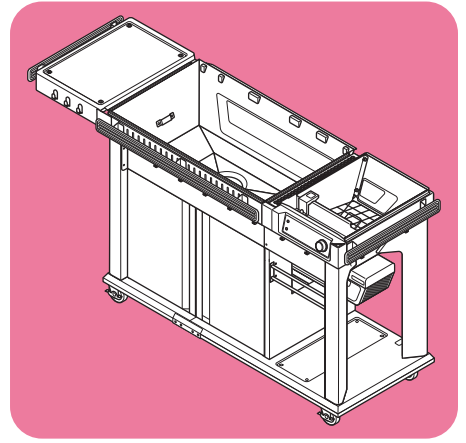

CHAPTER 4 – PAGE 40 LID & GRILL INTERNALS

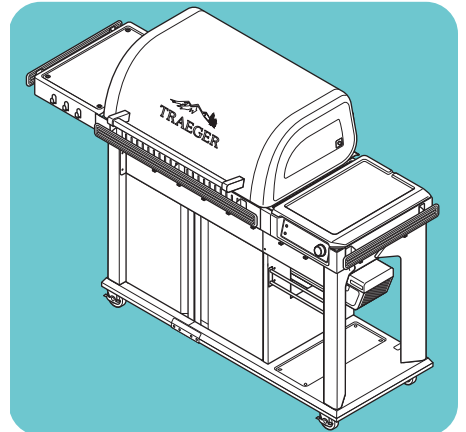

CHAPTER 1

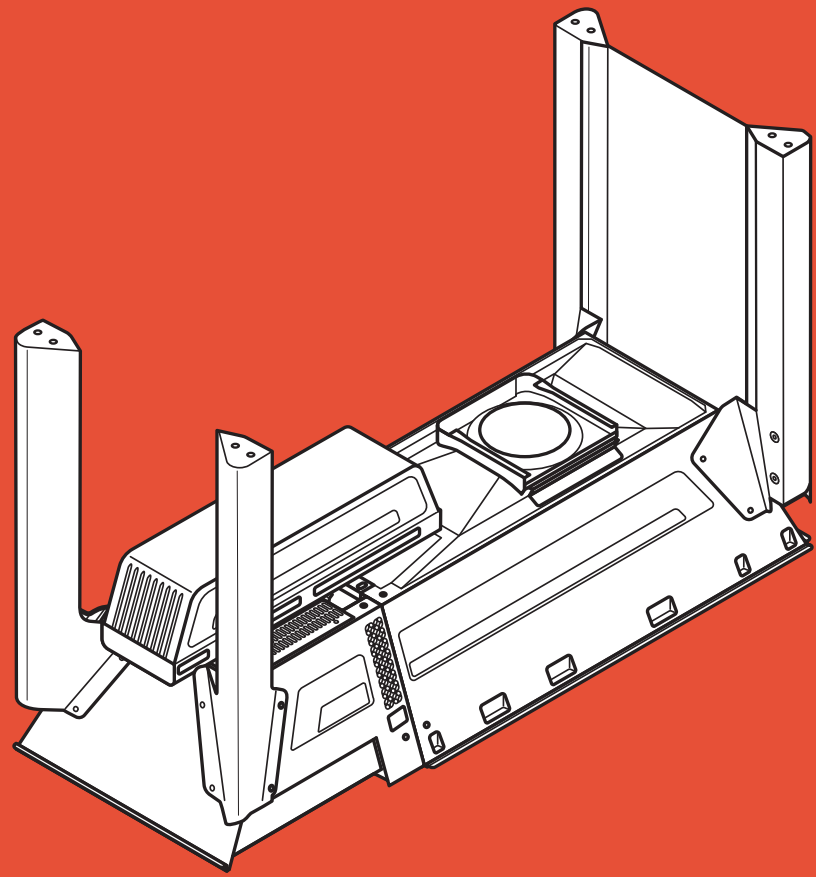

COMPARTMENTS & LEGS



CHAPTER 1

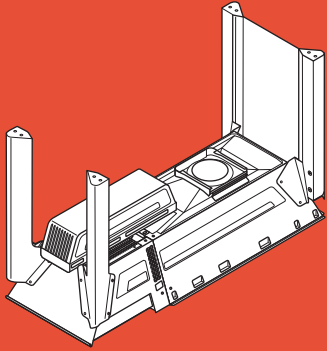

1 INSTALL SAFETY GRATE

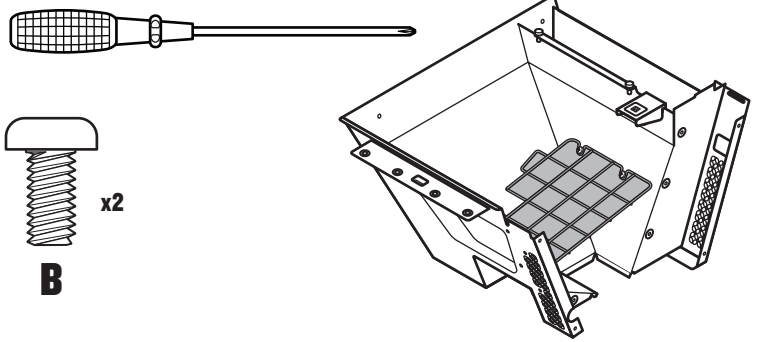

PRO TIP: Hand-tighten all screws first, then finish tightening with screwdriver.

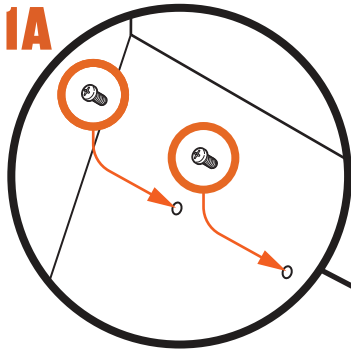

1B

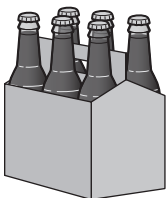
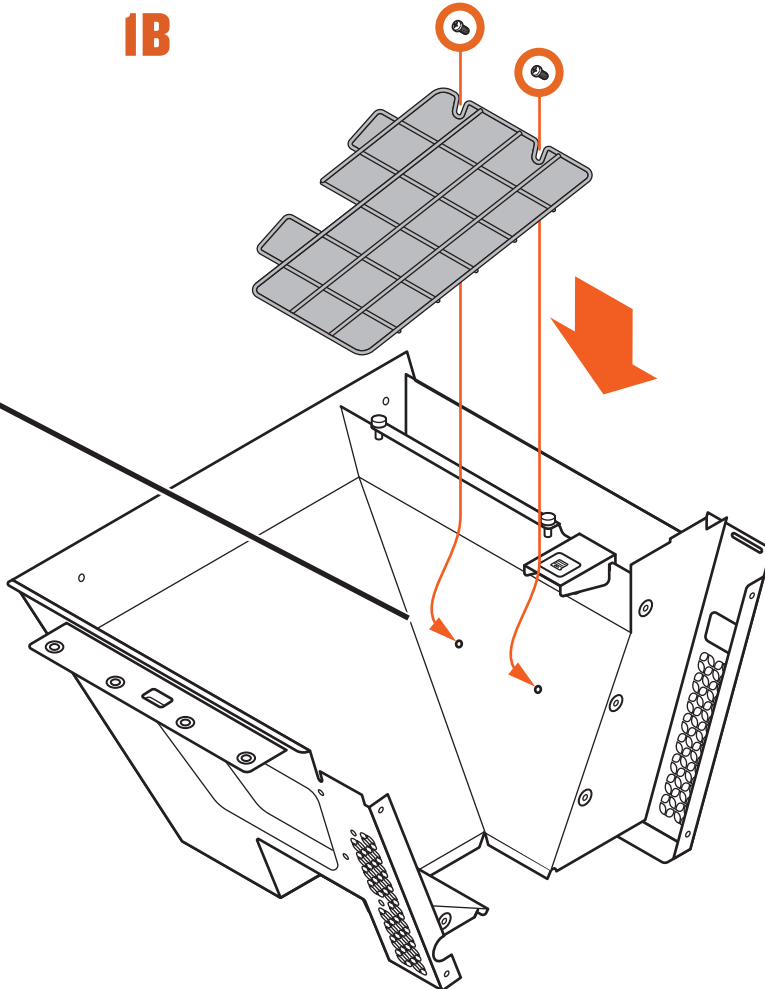



2 ASSEMBLE HOPPER

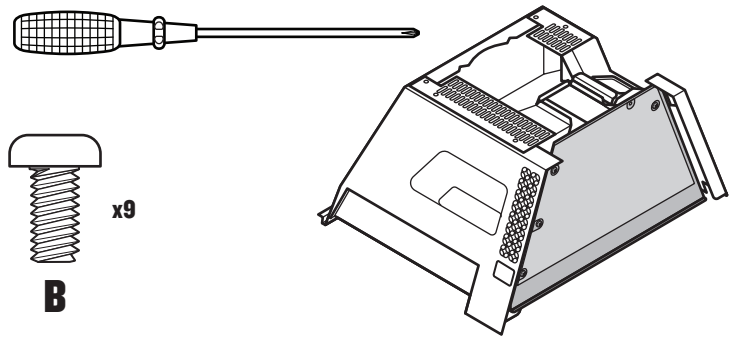

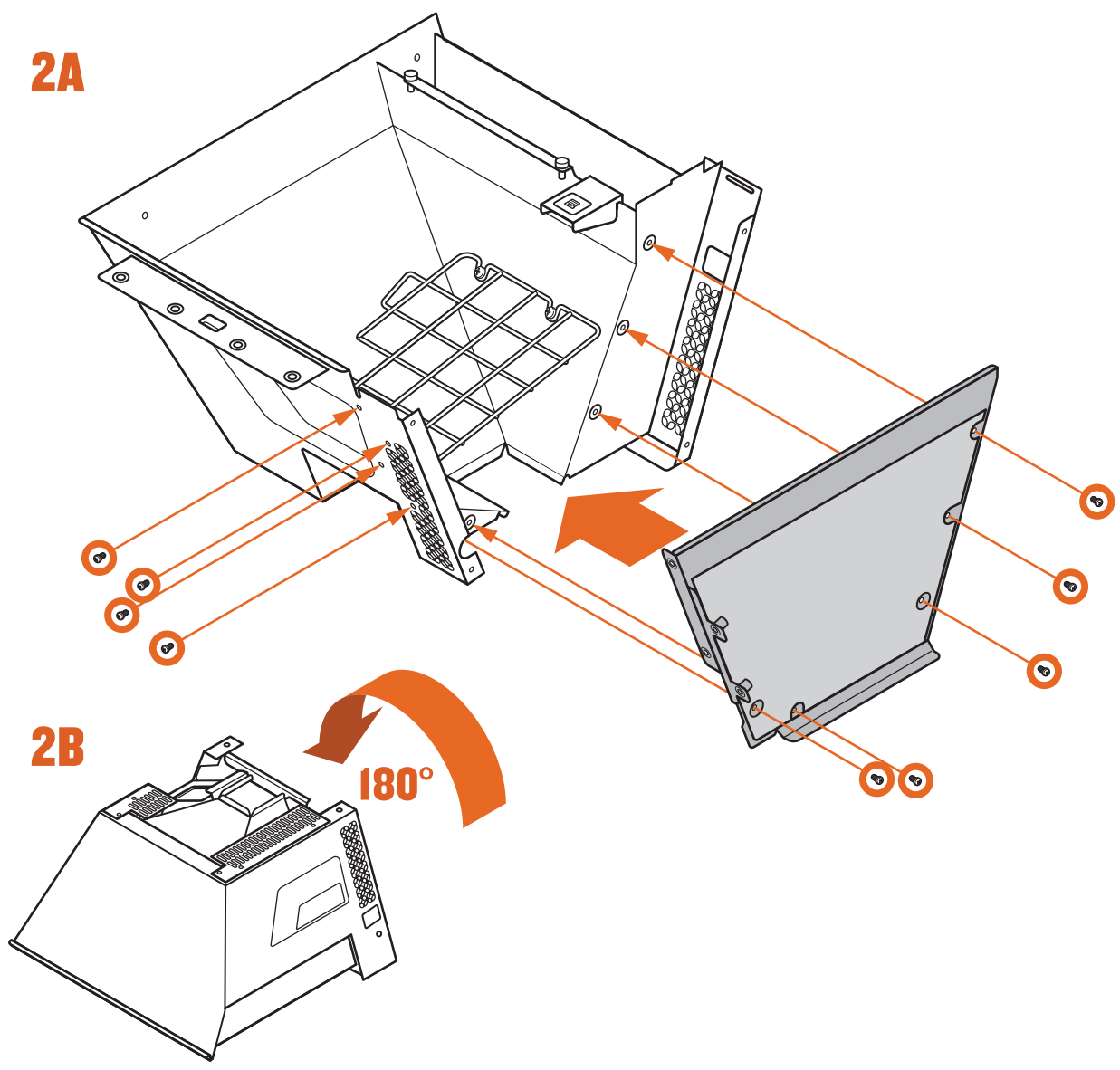

B x9



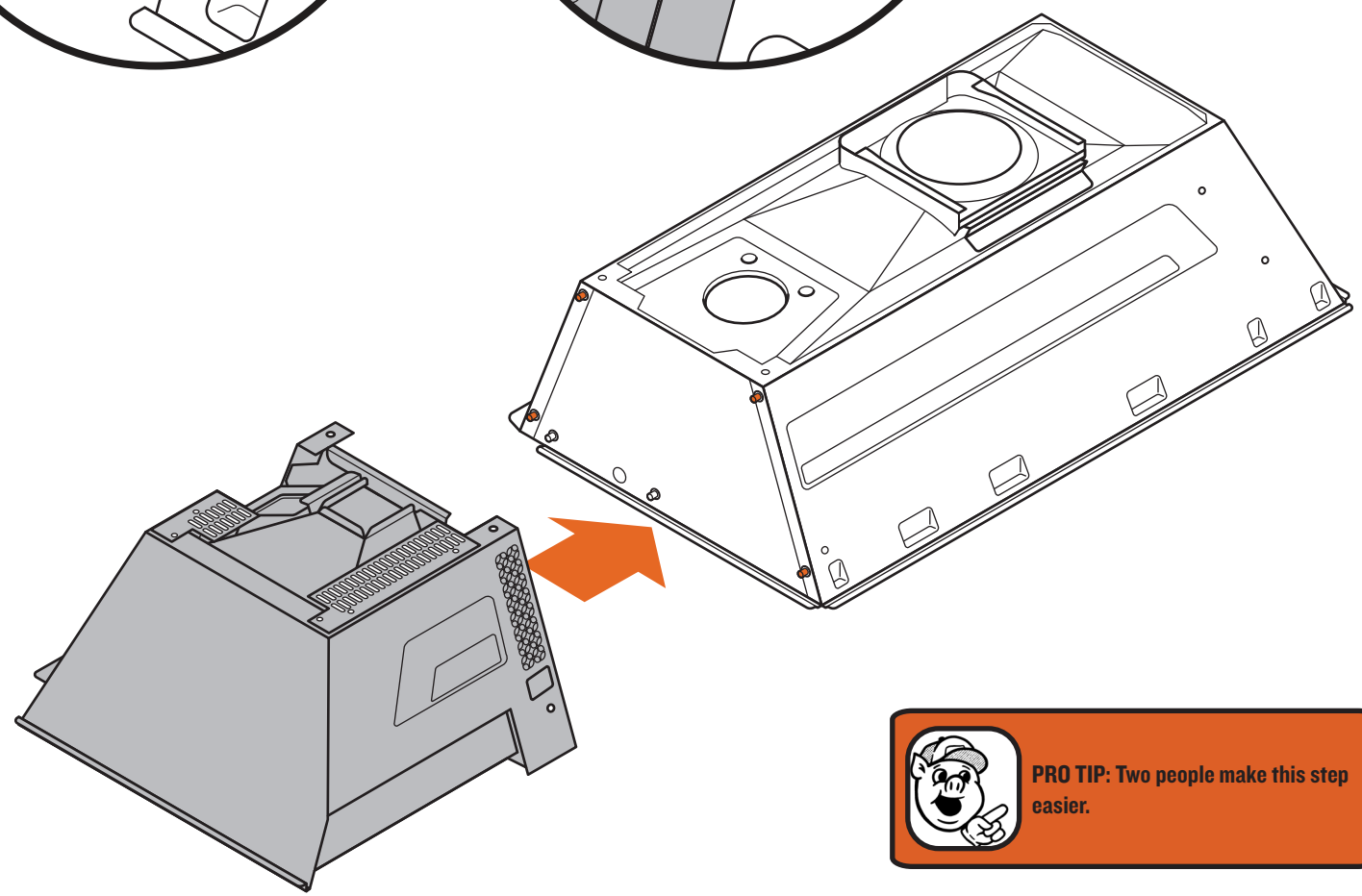
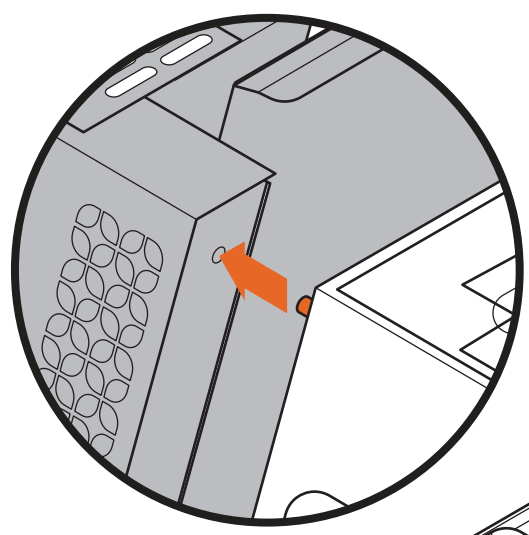
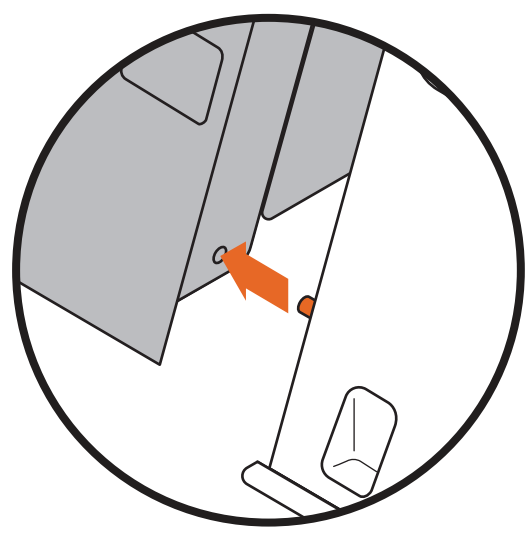
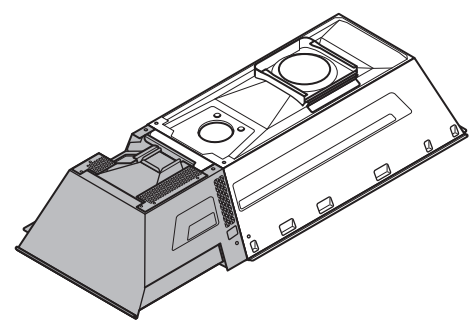

3A ATTACH HOPPER TO BODY



 **PRO TIP:** Two people make this step easier.





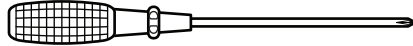
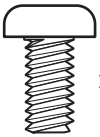

3B ATTACH HOPPER TO BODY

B x6

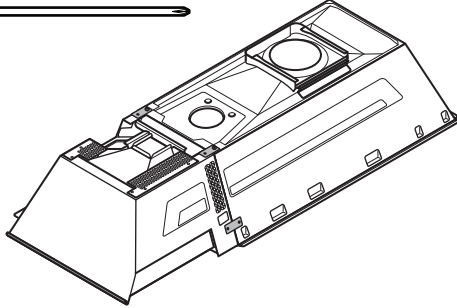
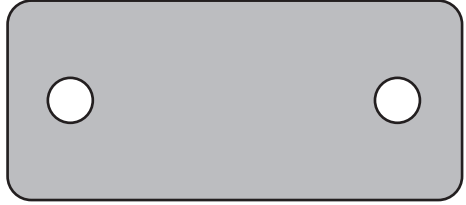
F x4



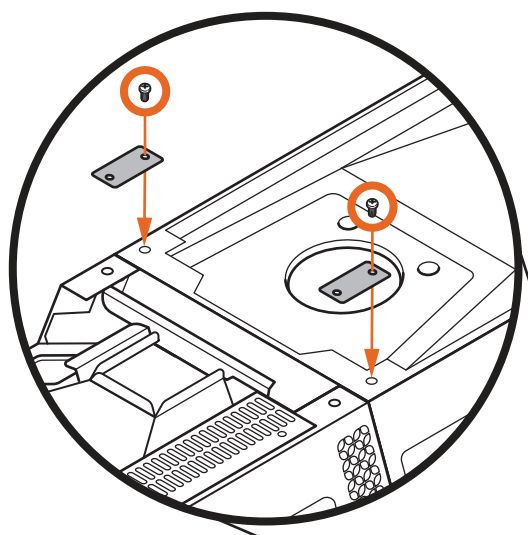

PRO TIP: Only install one screw in each top bracket.

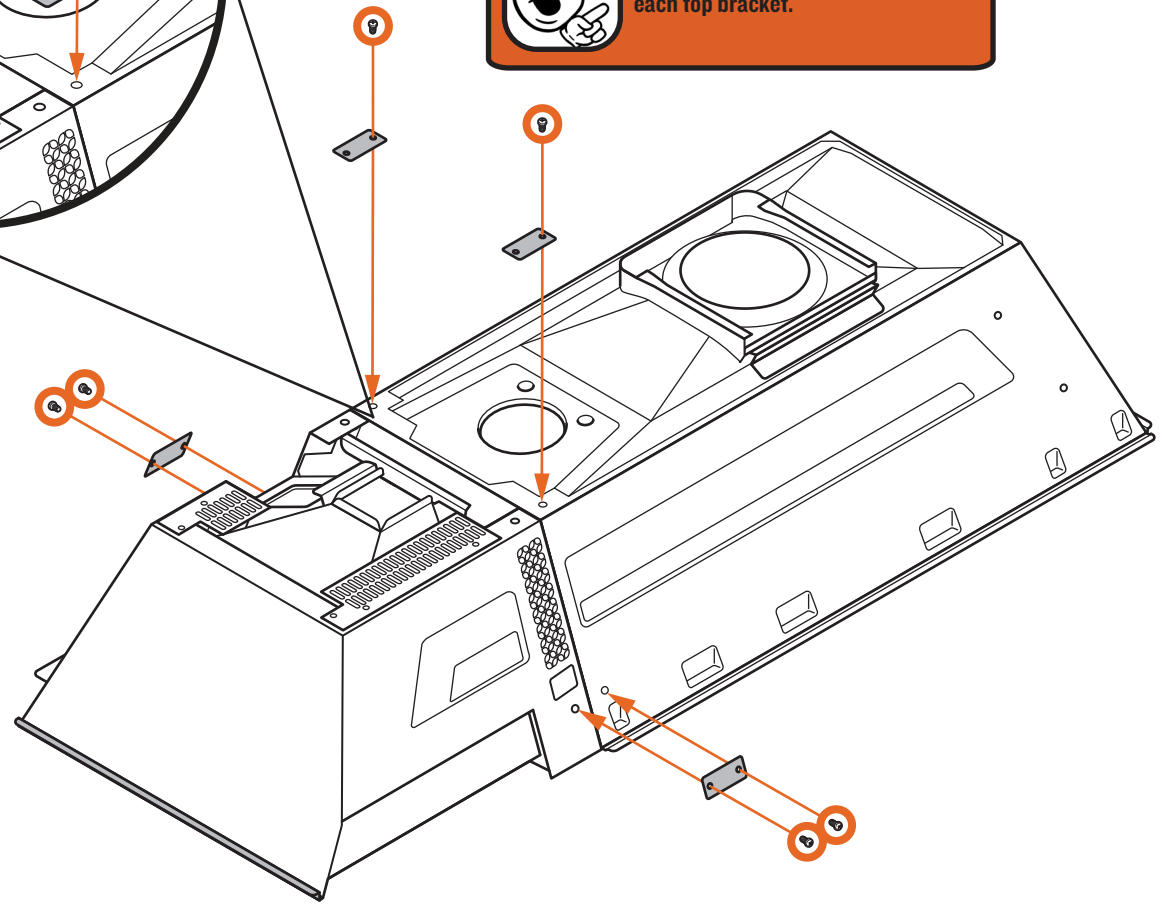

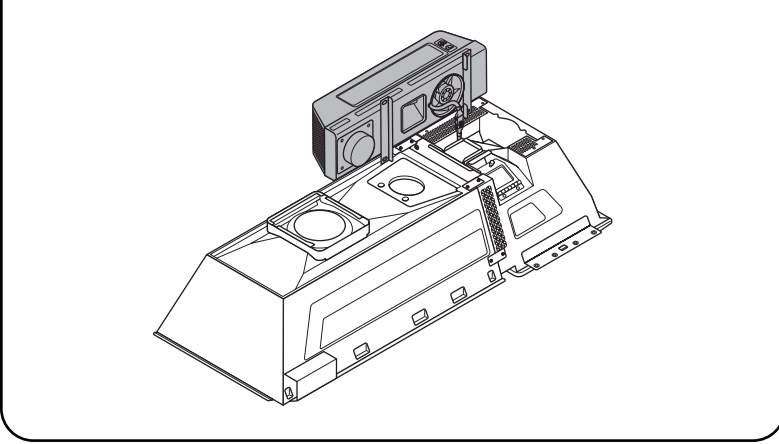
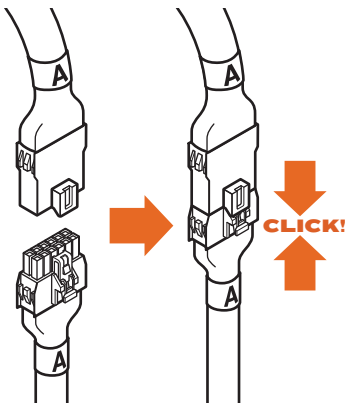

4 CONNECT AUGER BOX



 **PRO TIP:** Have a second person hold the auger box while you connect the cord.

 **PRO TIP:** Don't forget to remove the twist tie and tape holding down the cord.

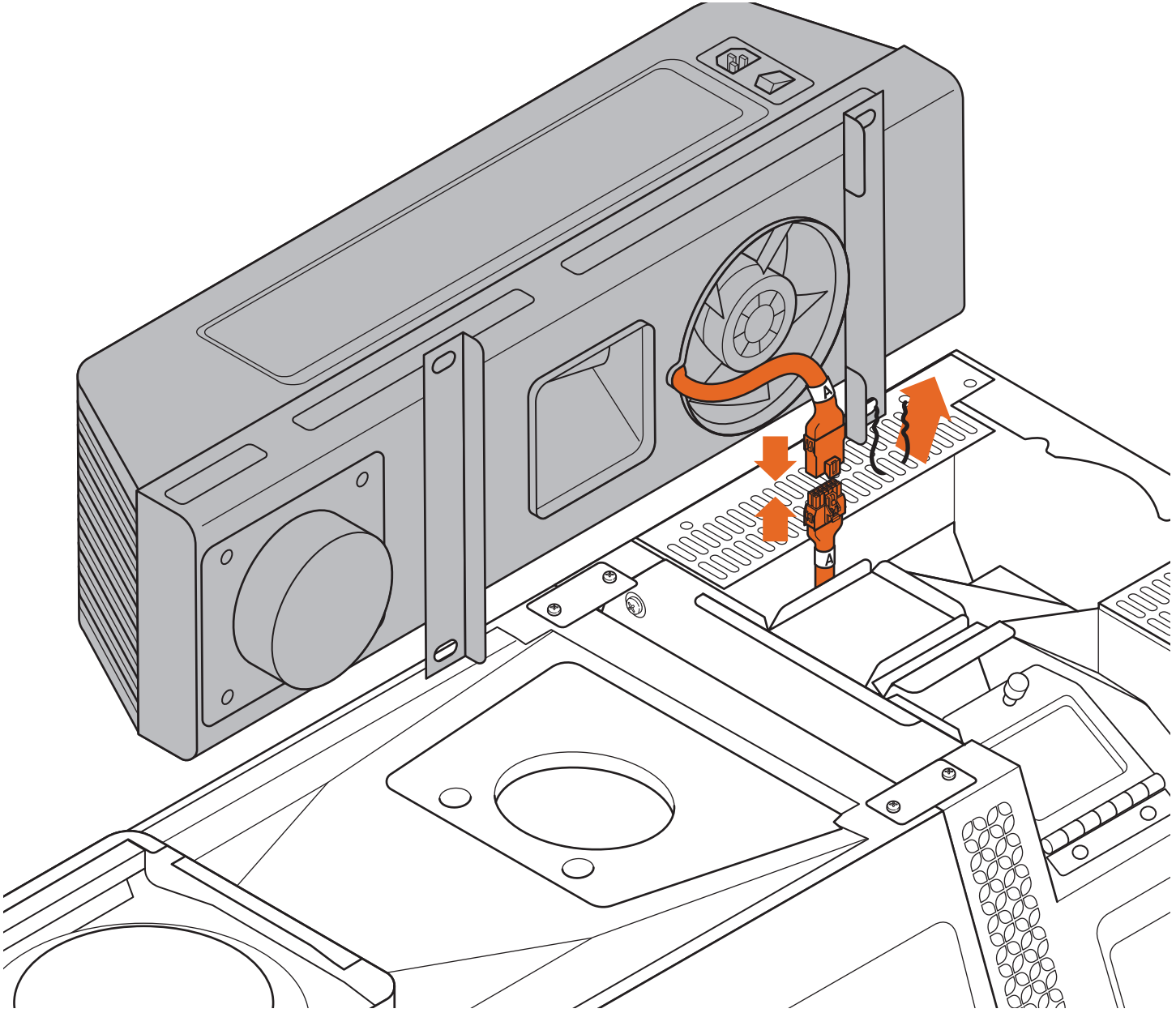



5 ATTACH AUGER BOX

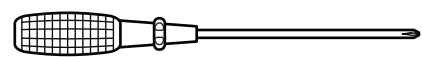

Use **THIS** screw now!

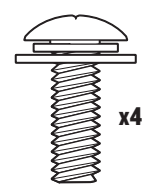

x4

A

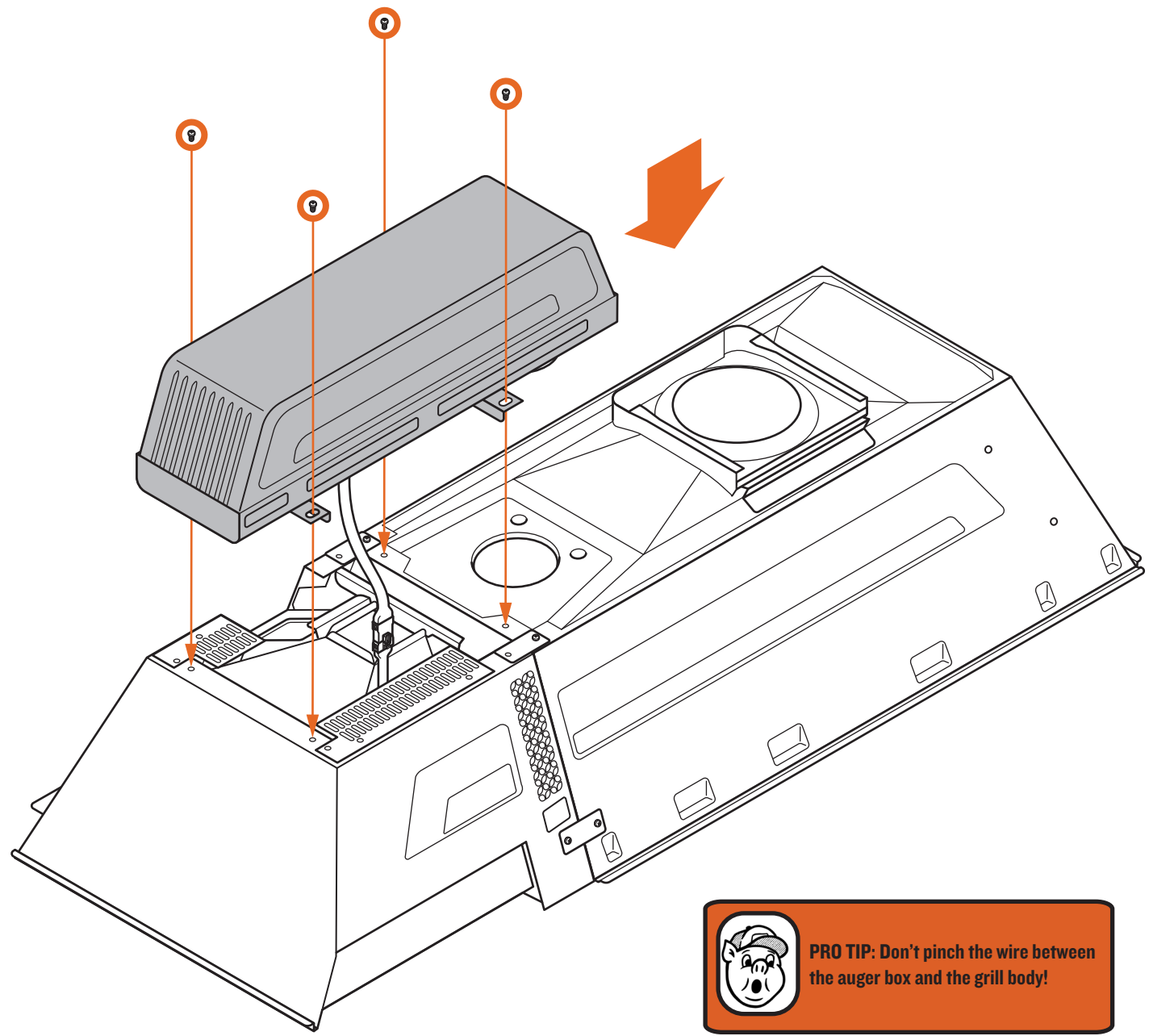
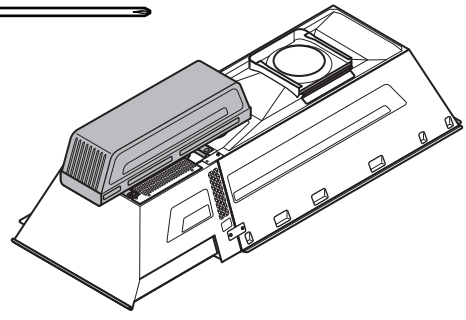

 **PRO TIP:** Don't pinch the wire between the auger box and the grill body!



6 ATTACH LEGS

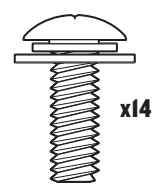
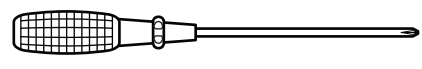

A

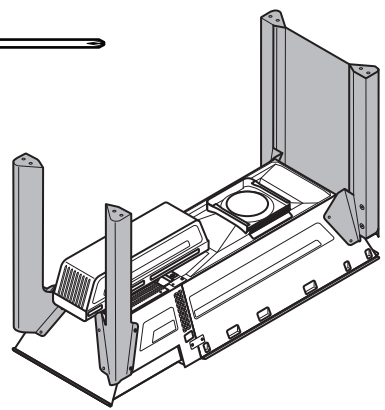

 **PRO TIP:** Line up screw holes in legs with screw holes in grill body and hopper.

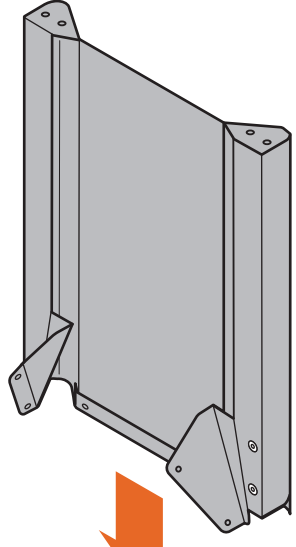

 **PRO TIP:** You can gently squeeze the legs to align the screws before you finish tightening with a screwdriver.

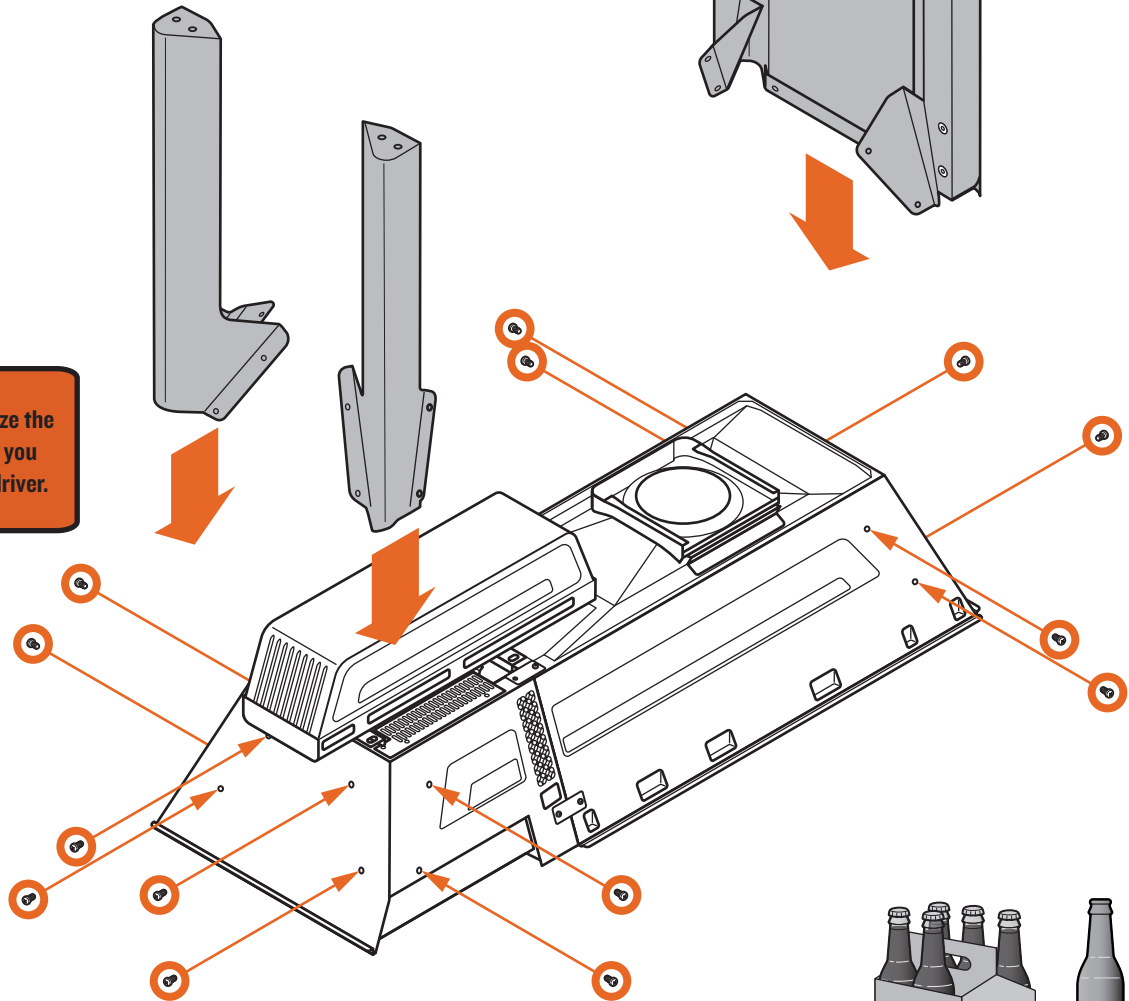

NICE WORK!
CHAPTER 1 COMPLETE!

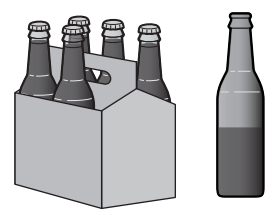

CHAPTER 2

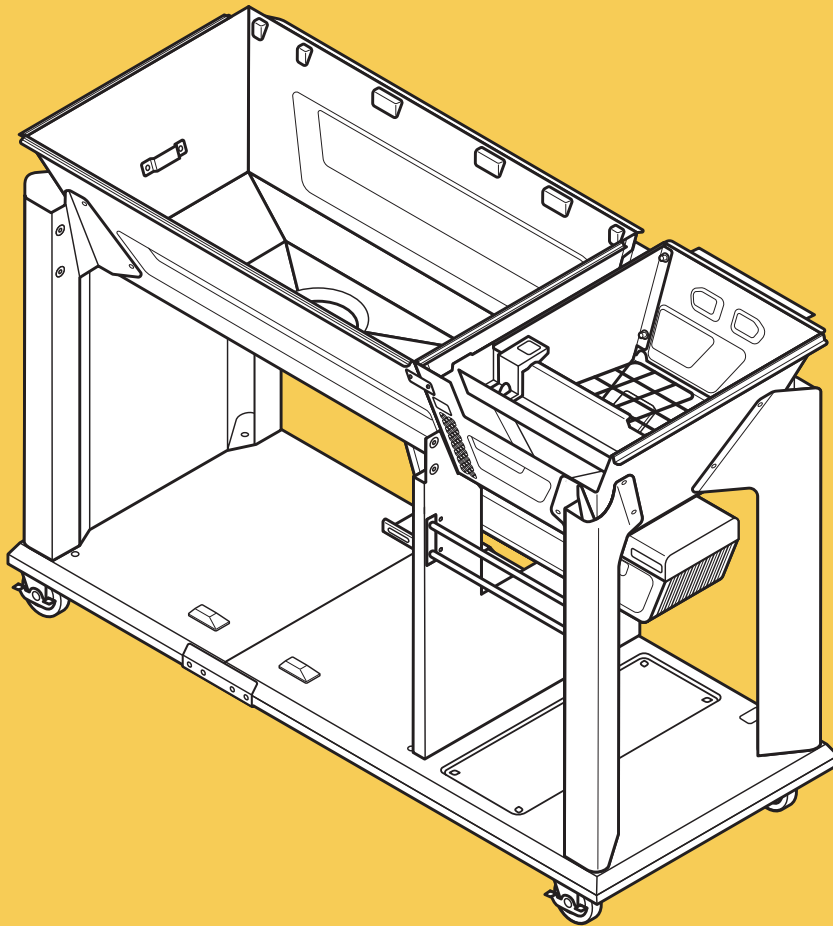

CABINET & CASTERS

CHAPTER 2

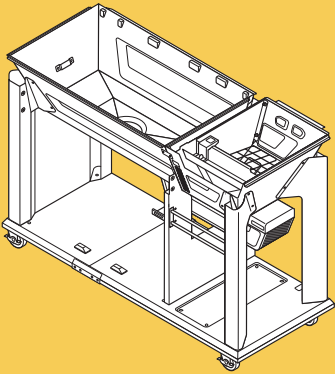

1 ASSEMBLE BASE

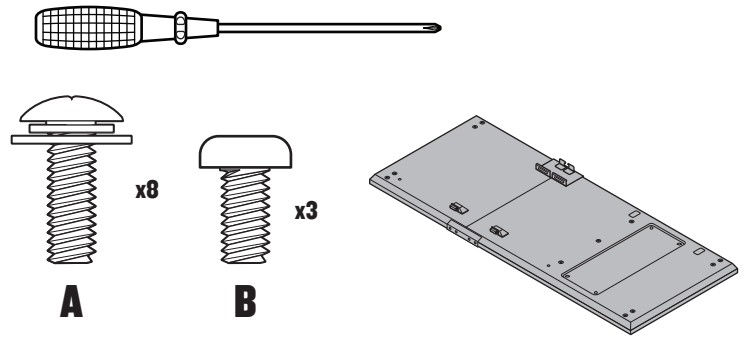

 **PRO TIP:** Hand-tighten all screws first, then finish tightening with screwdriver.

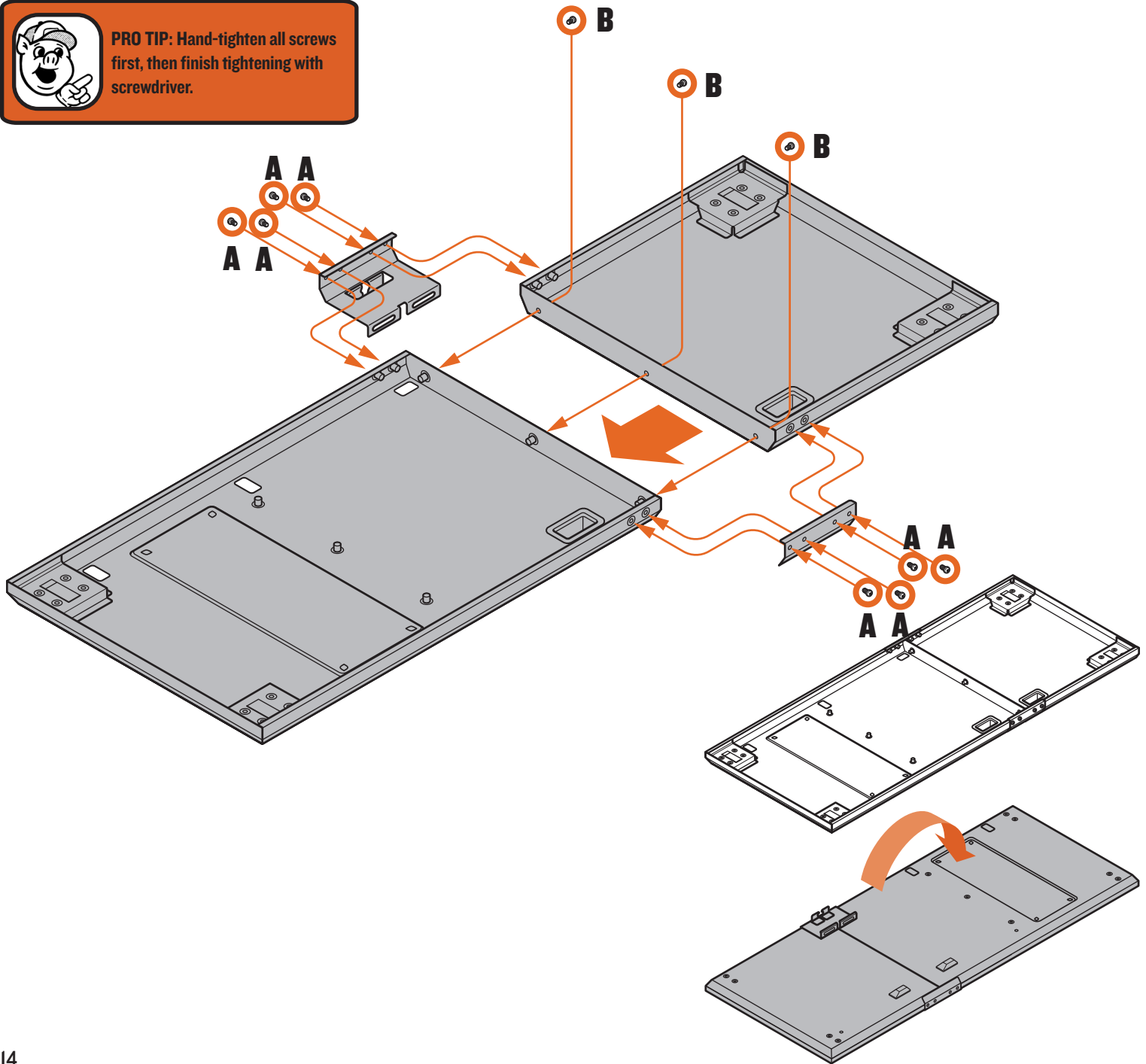



2 ATTACH MIDDLE WALL

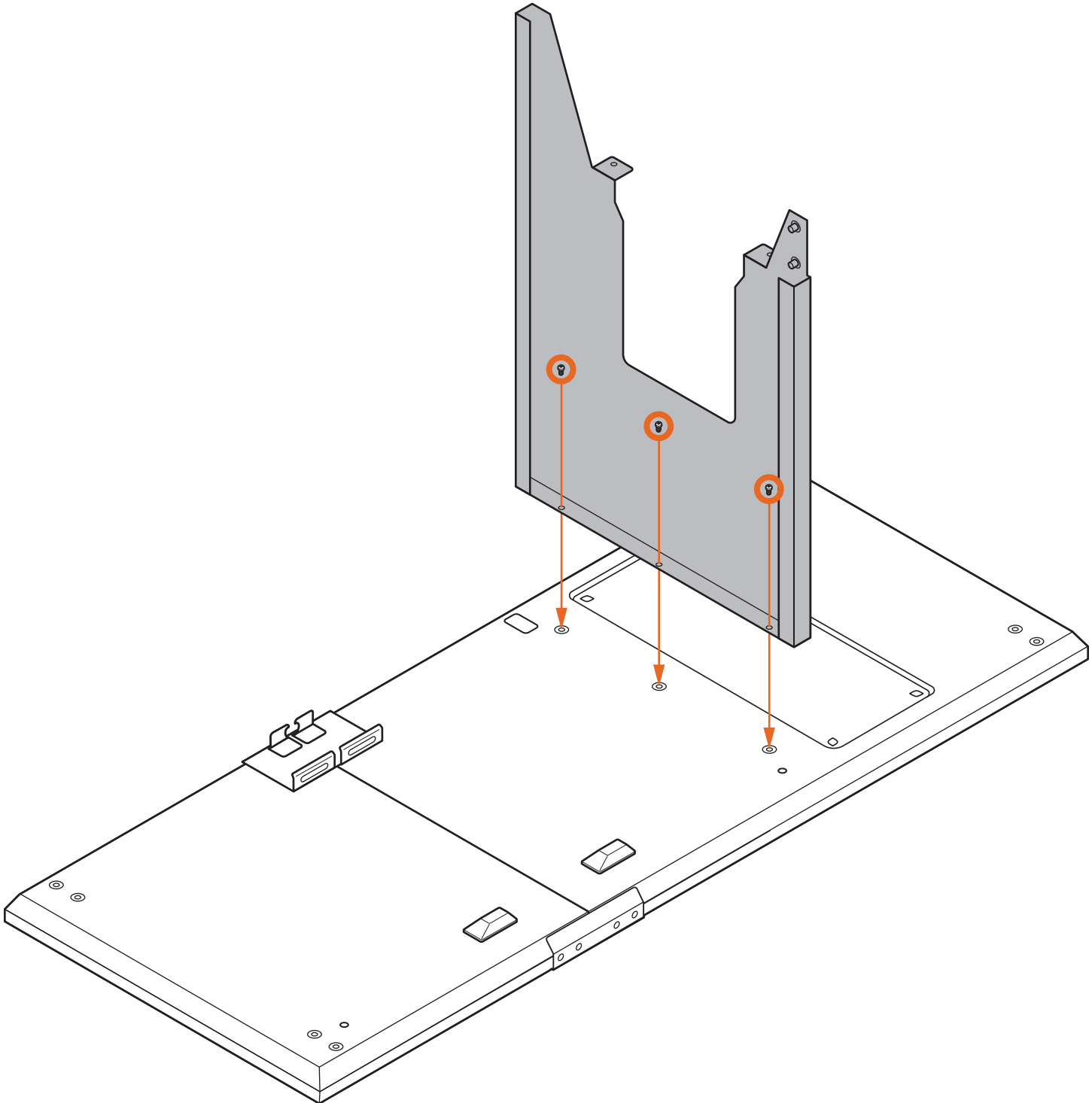
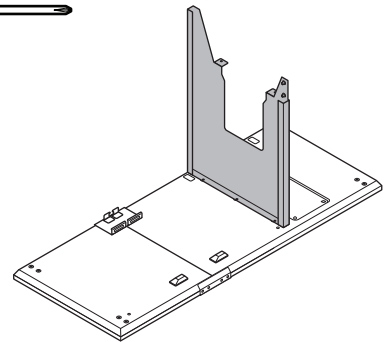
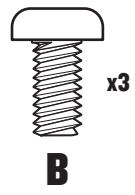
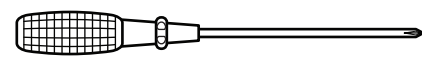



 **PRO TIP:** Have a second person help lift and rotate the base.

3A ATTACH BASE TO GRILL BODY

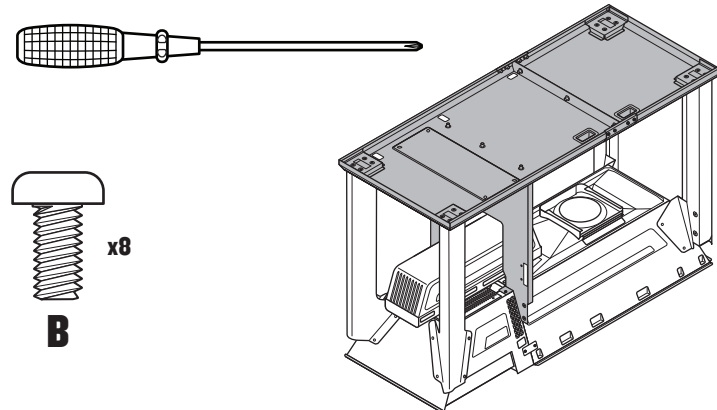
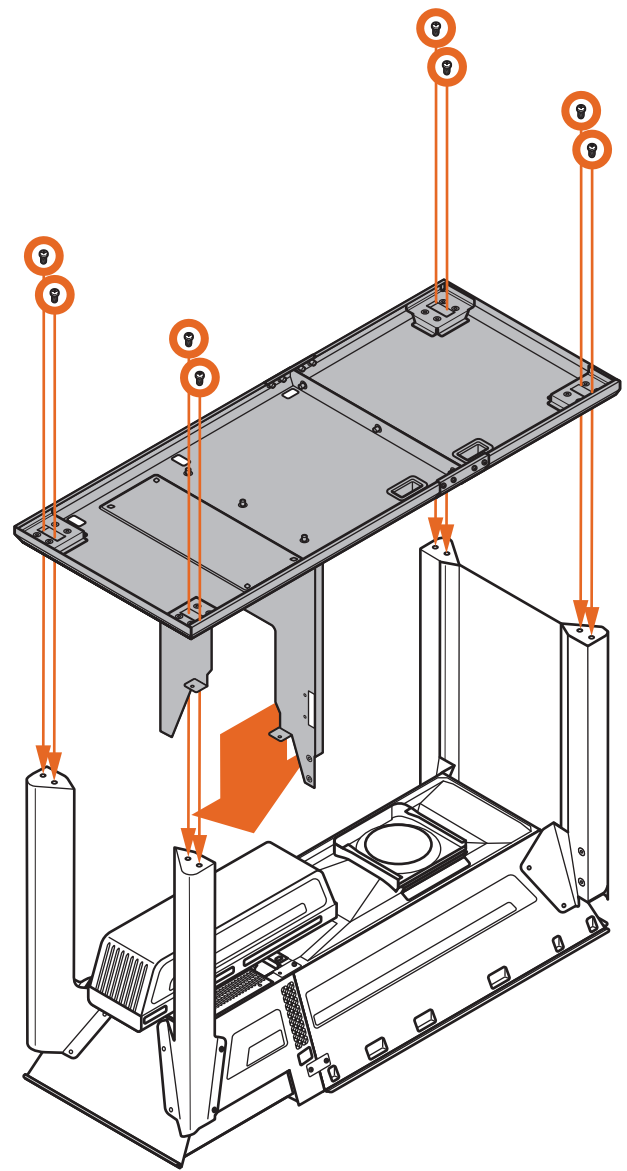
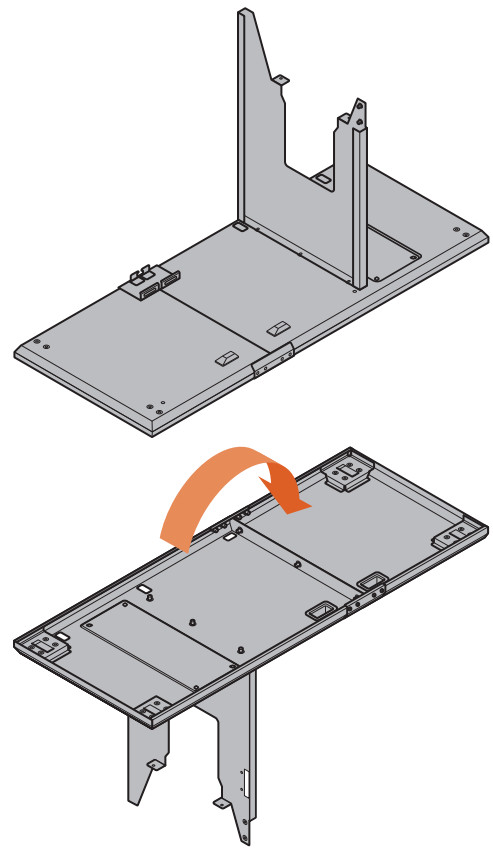



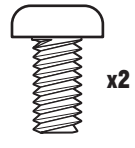
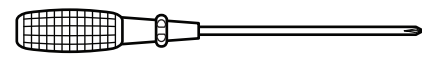

3B ATTACH BASE TO GRILL BODY

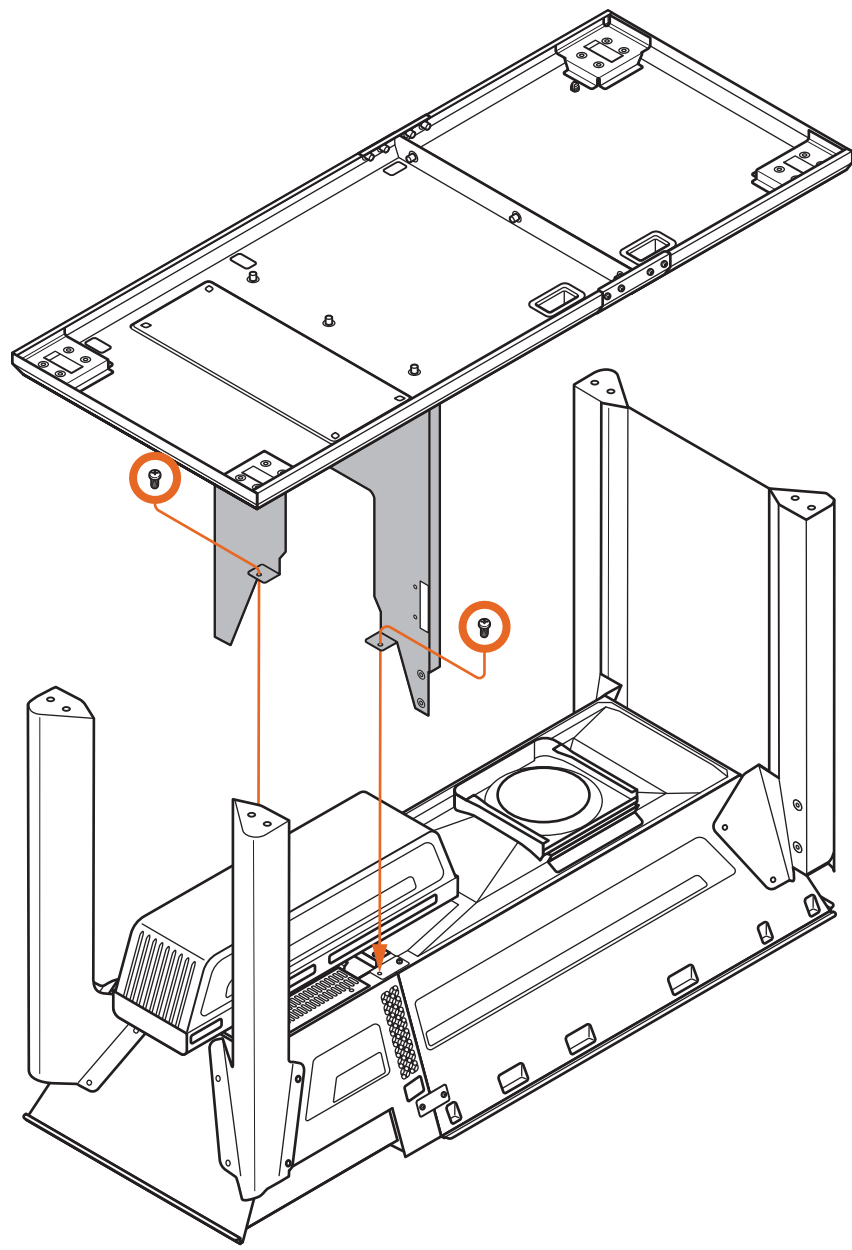
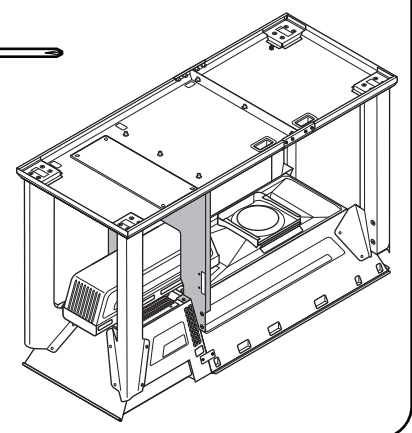

B





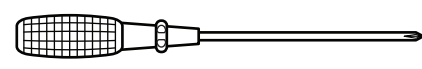

PRO TIP: This step uses different hardware!

4 ATTACH CASTERS

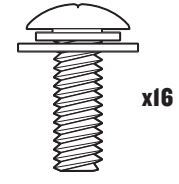

Use **THIS** screw again!



A

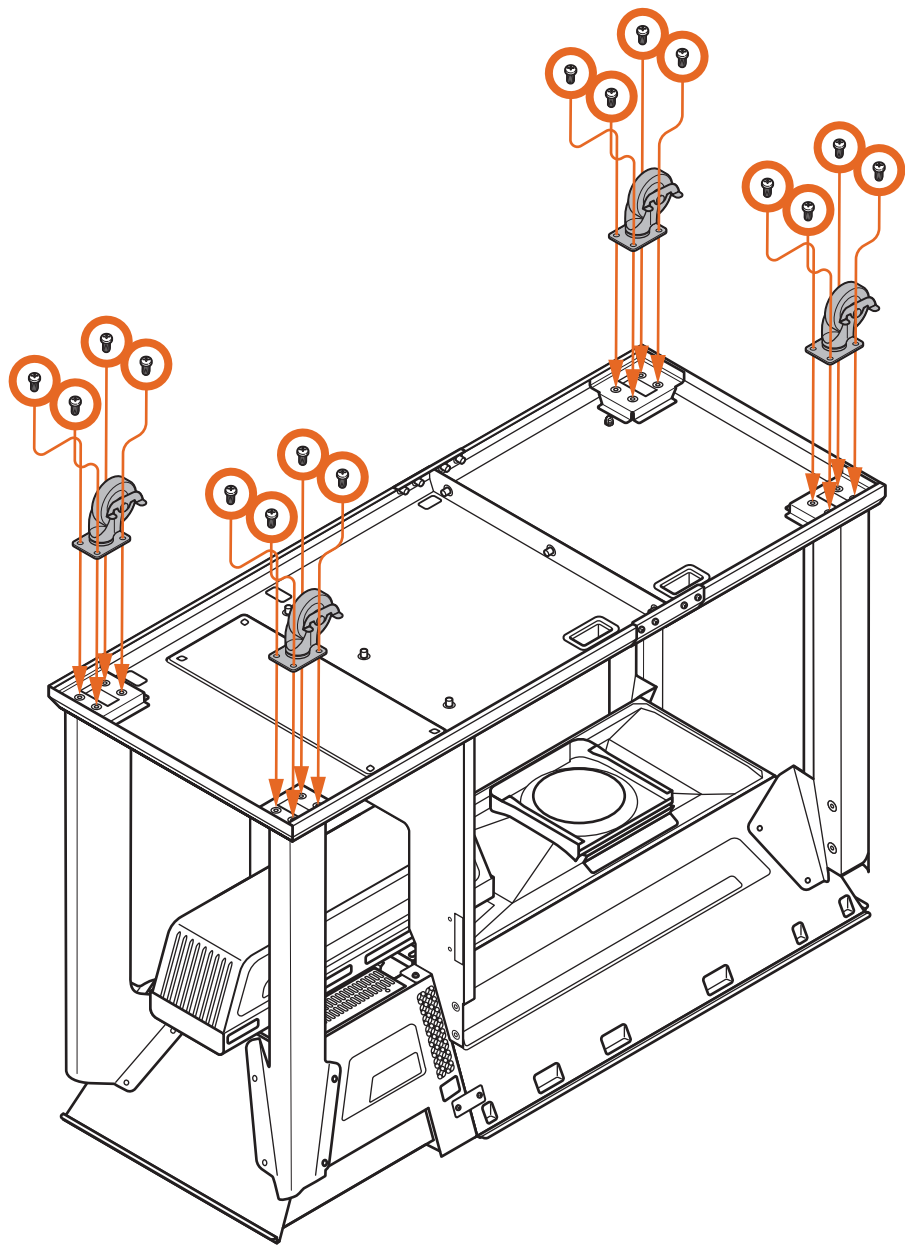
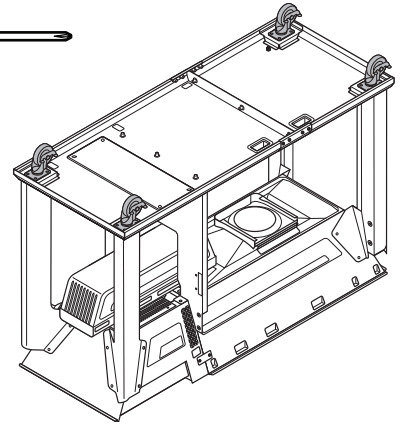



 **PRO TIP:** Have a second person help lift and rotate the grill.

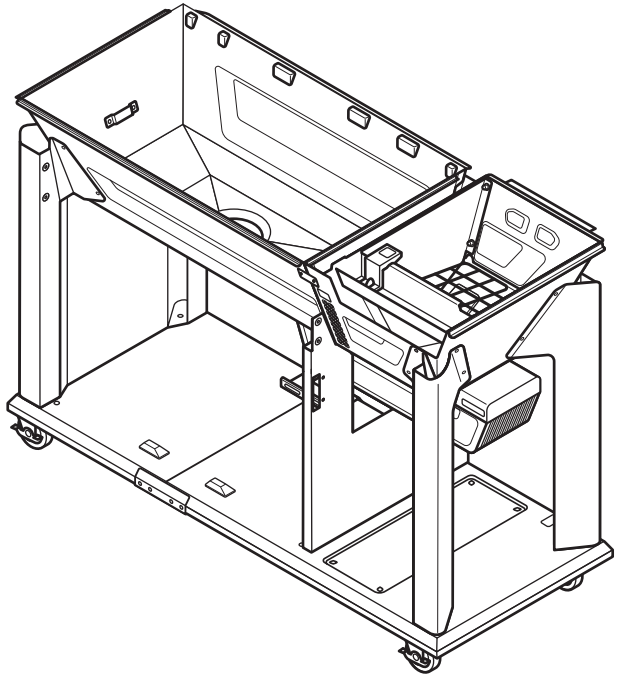
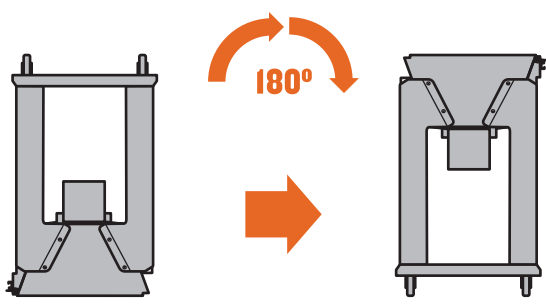
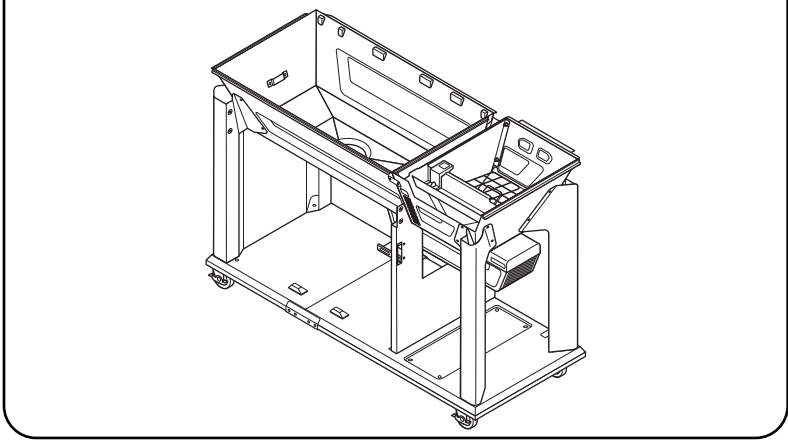

5 FLIP GRILL OVER



 **PRO TIP:** Lock casters to prevent grill from possibly rolling.



PRO TIP: If you need help with this step, scan this QR code for our animated instructions.

6 ATTACH P.A.L. UTILITY RACK

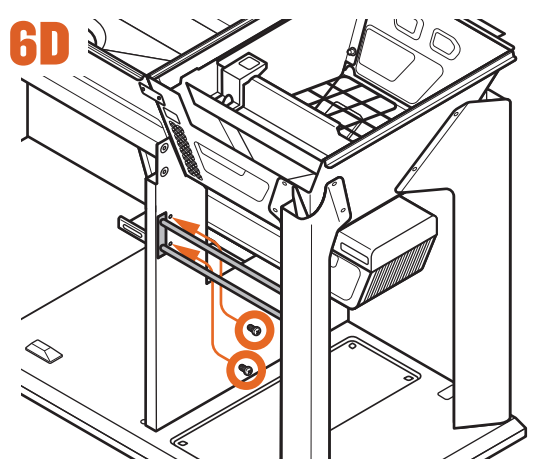
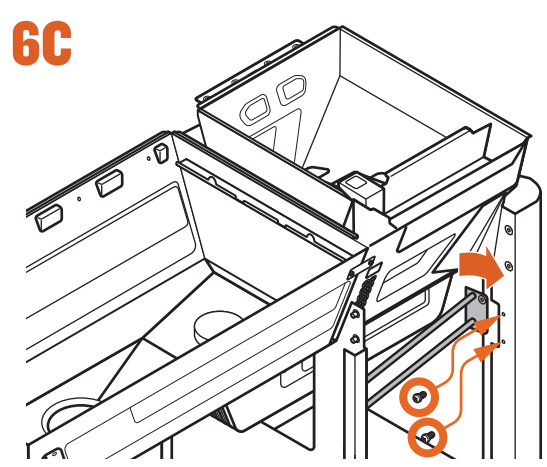
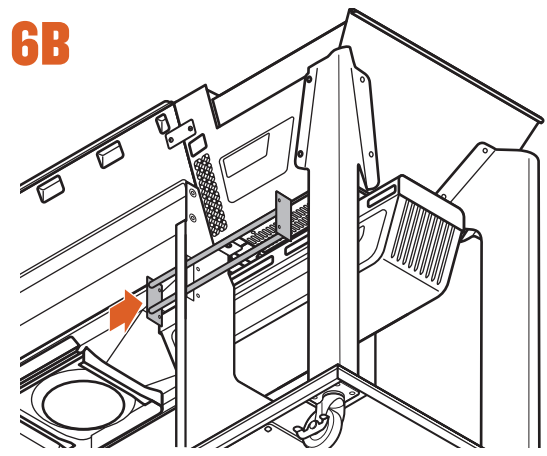
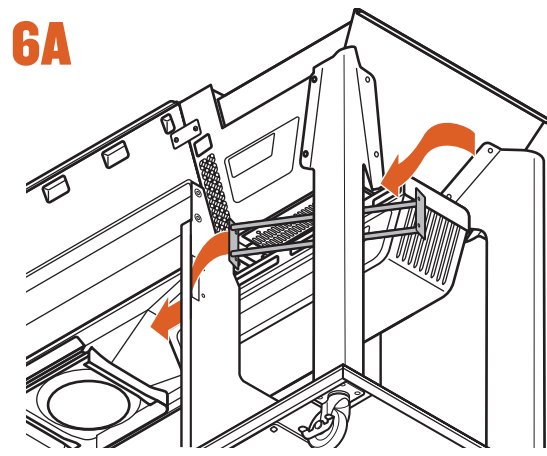
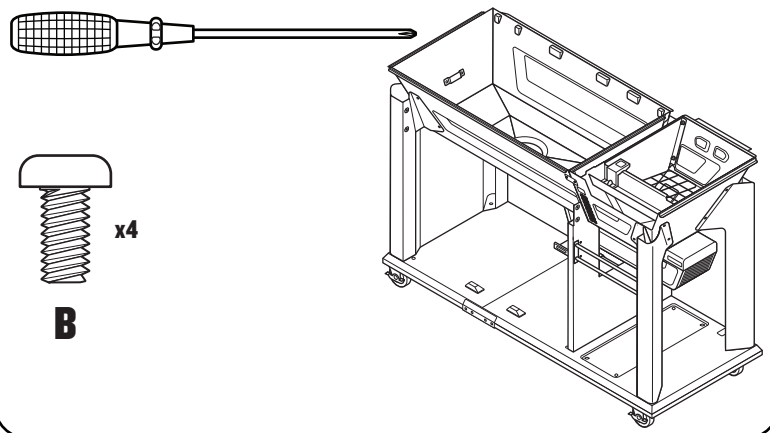

**NICE WORK!
CHAPTER 2 COMPLETE!**

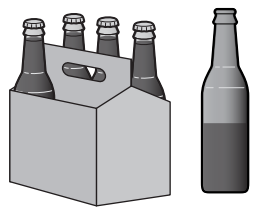

CHAPTER 3

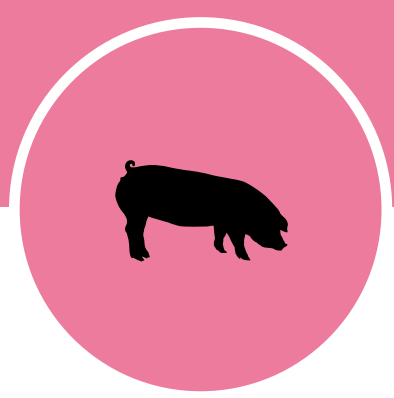
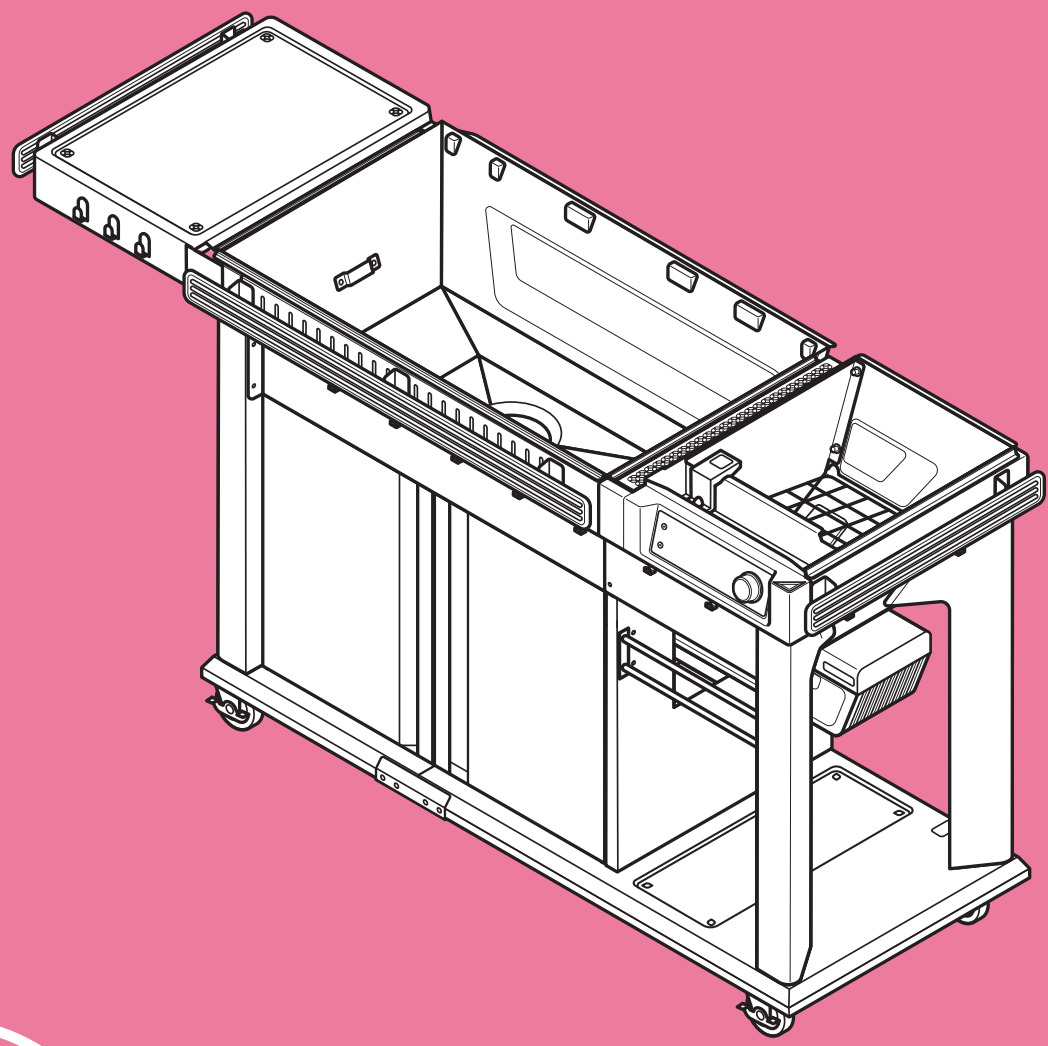

FOLDING SIDE SHELF, BASE, & CONTROLLER

CHAPTER 3

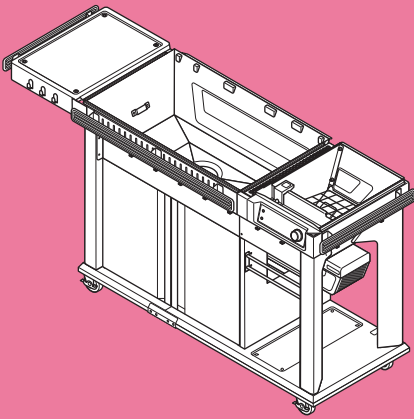

1 BUILD P.A.L. RAILS

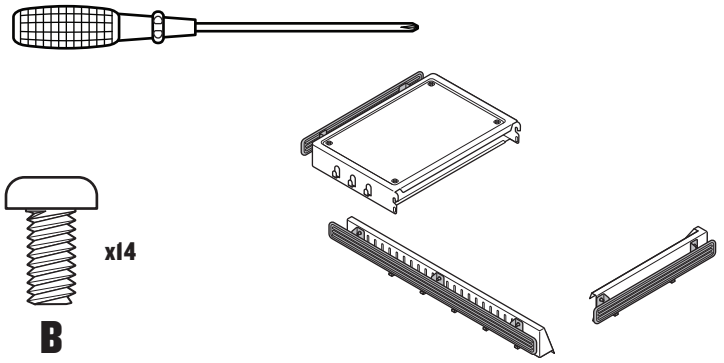

PRO TIP: Hand-tighten all screws first, then finish tightening with screwdriver.

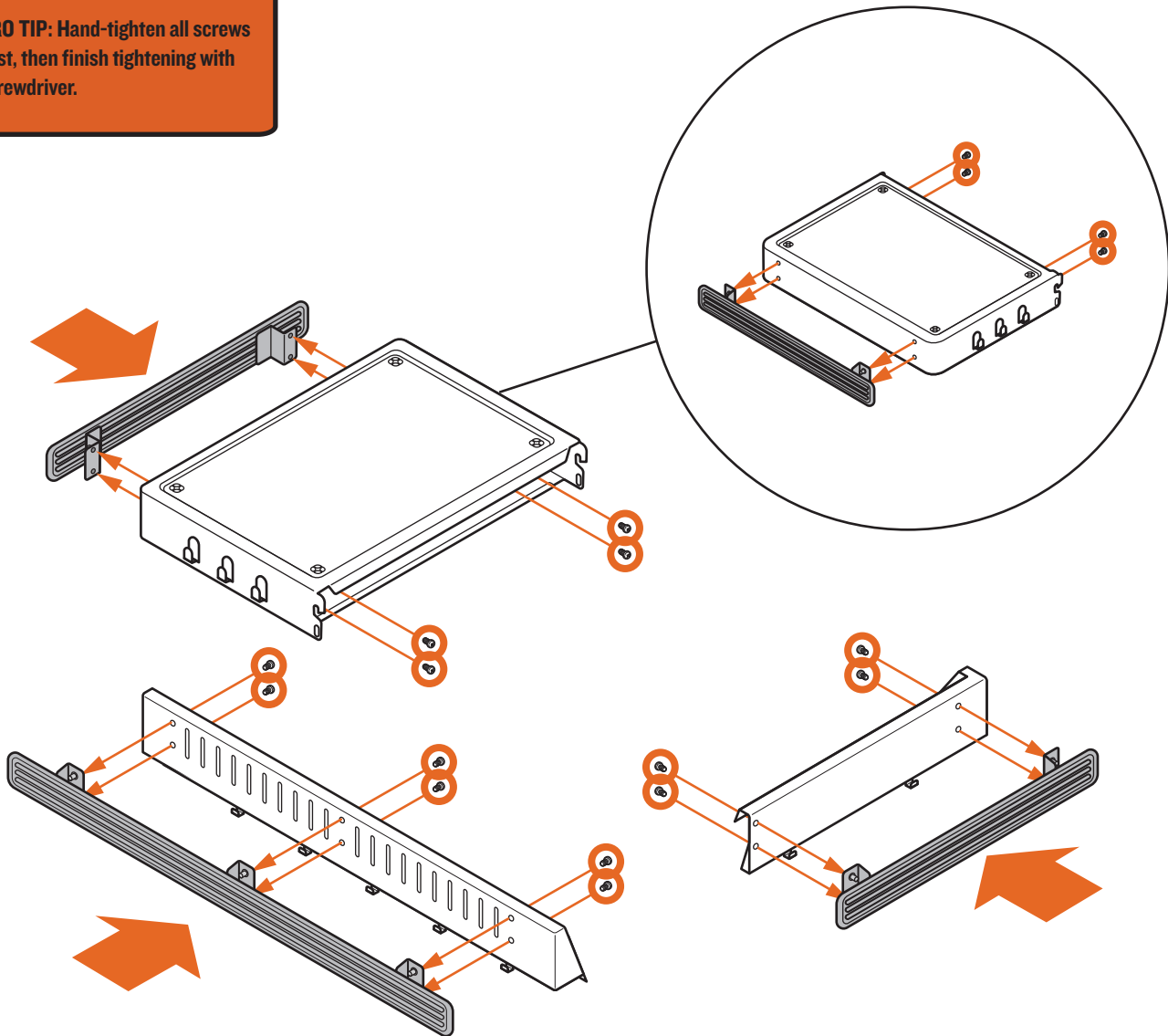



PRO TIP: This step can be tricky. Scan our QR code to access video animations for assembly. Jump to Chapter 3, Step 2 for a video.



PRO TIP: To prevent hardware from falling into the auger box, lay this manual on top of the grate.

2 ATTACH P.A.L. TRIM

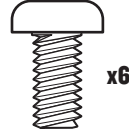
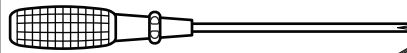

x6

B

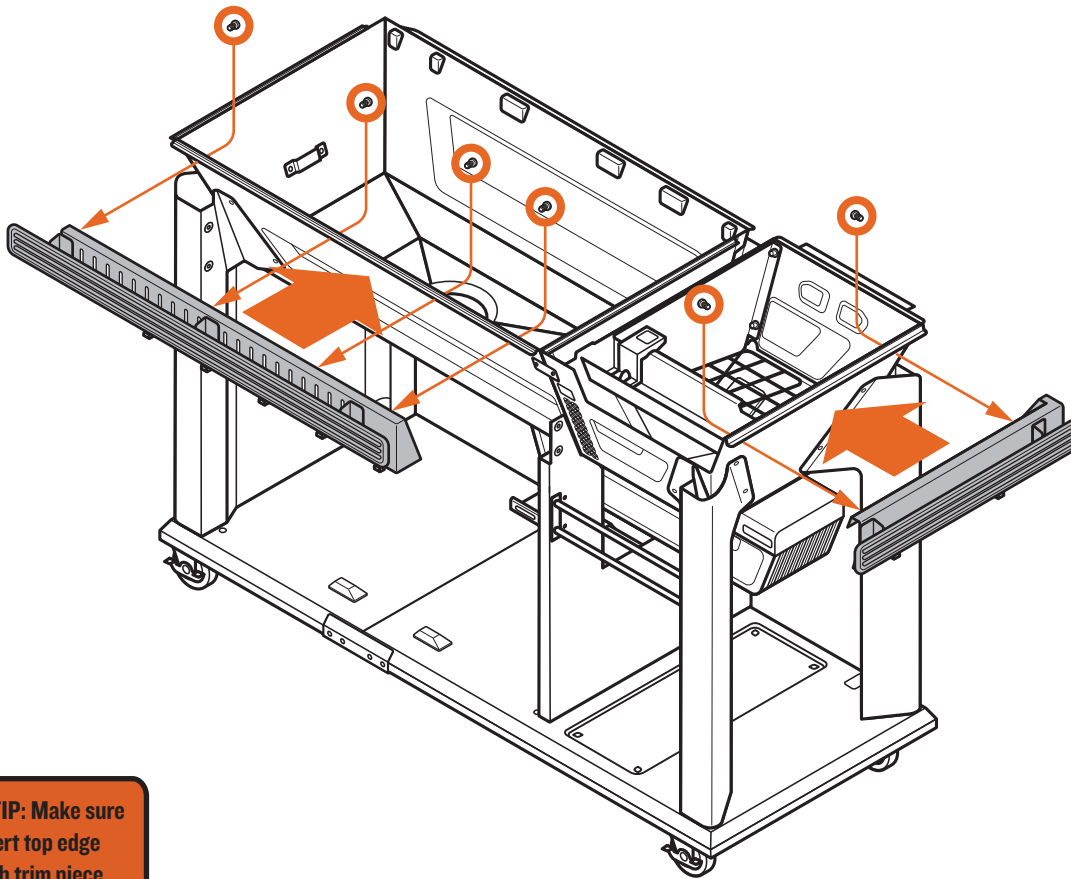
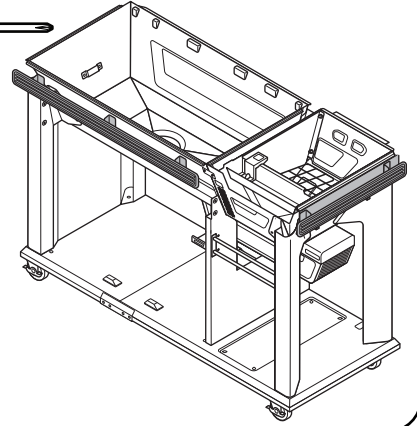

PRO TIP: Make sure to insert top edge of each trim piece under flange on grill.

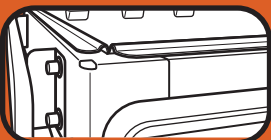



3 SECURE P.A.L. TRIM

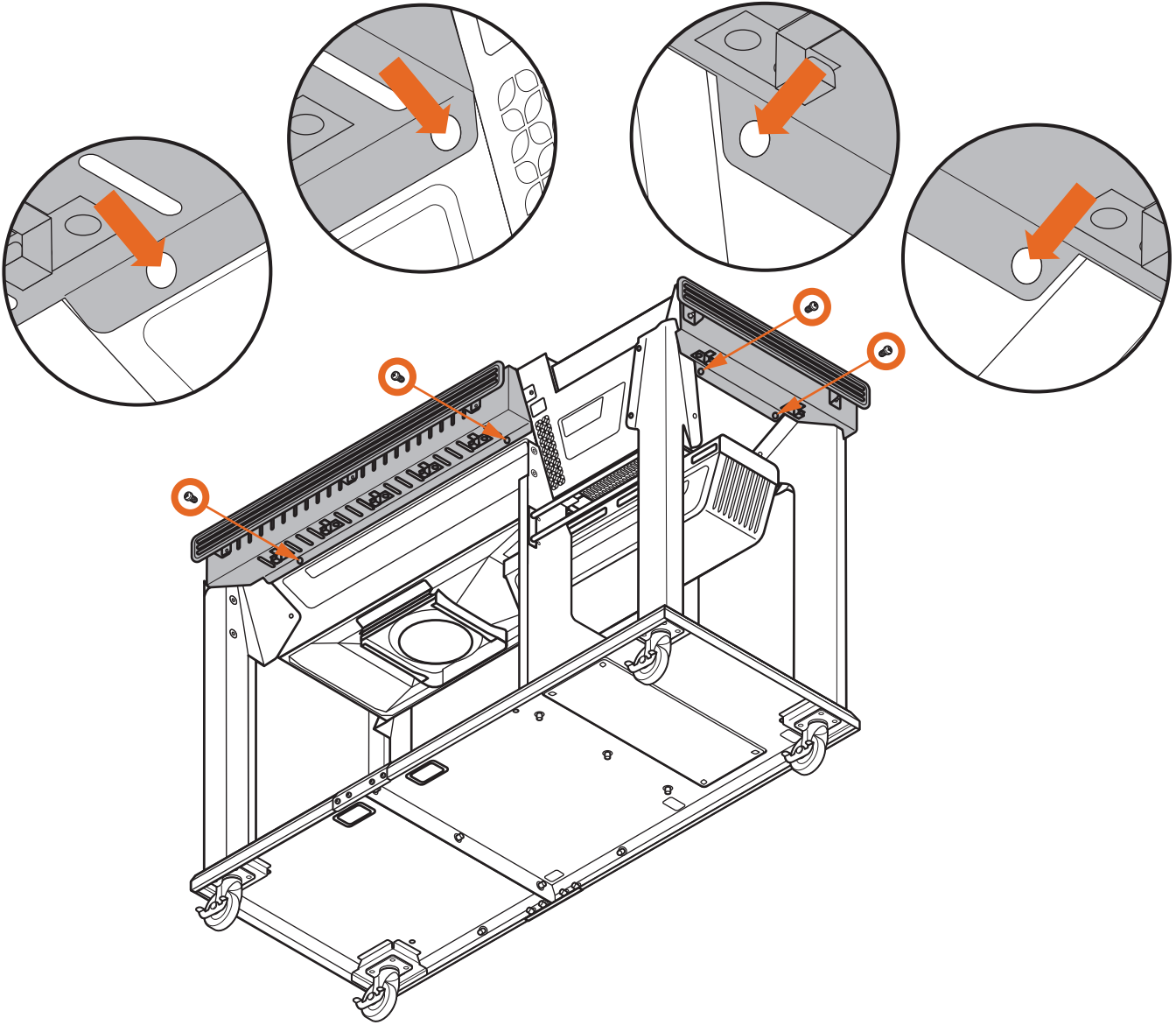
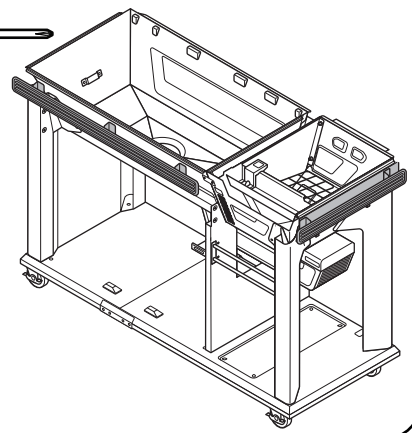
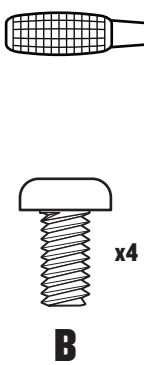



4A ATTACH FOLDING SIDE SHELF

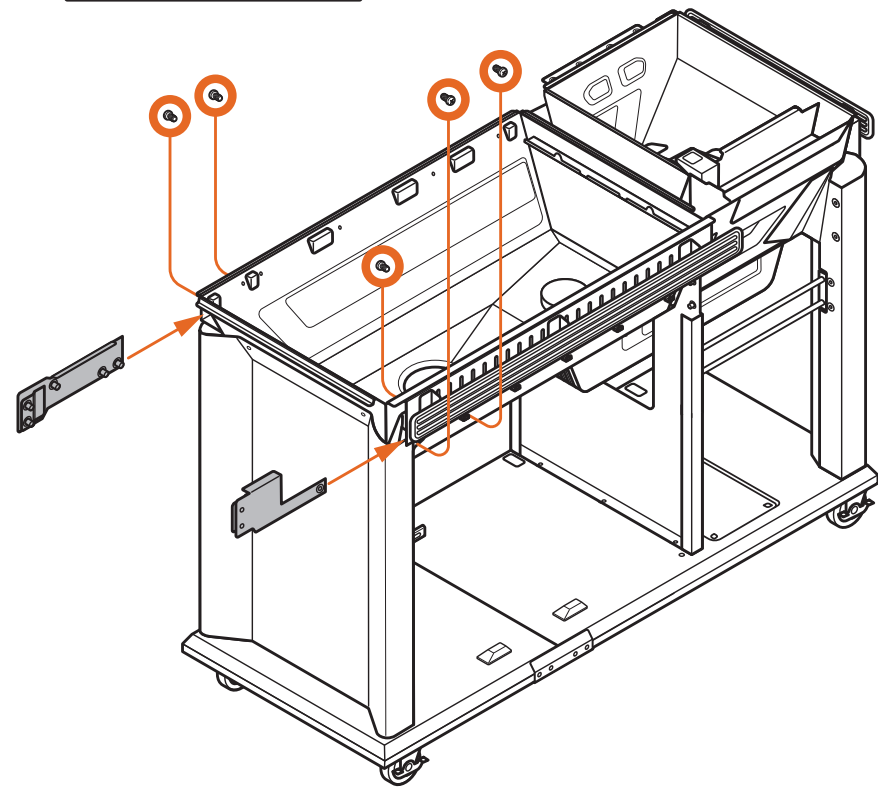
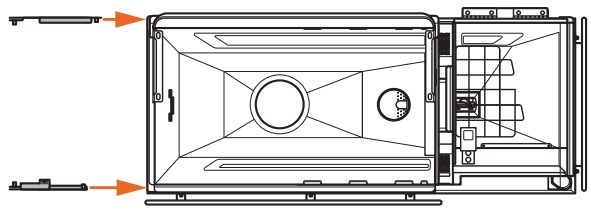
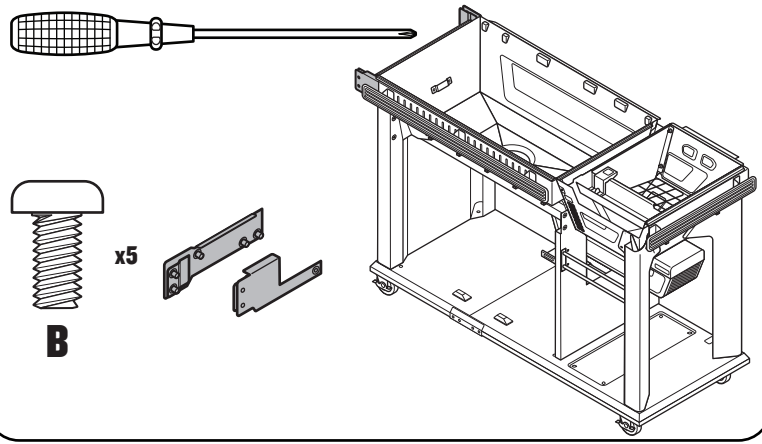



PRO TIP: Hand-tighten all screws first, then finish tightening with screwdriver.

4B ATTACH FOLDING SIDE SHELF

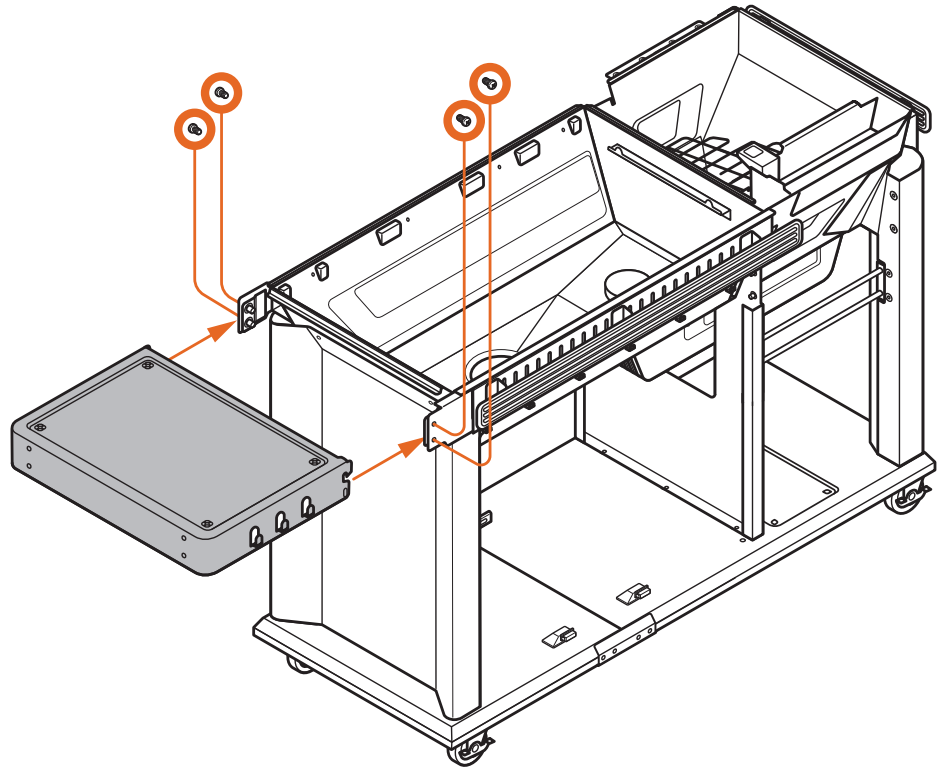
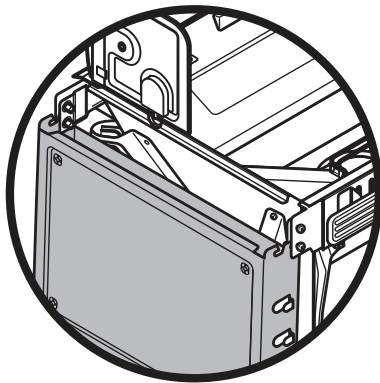
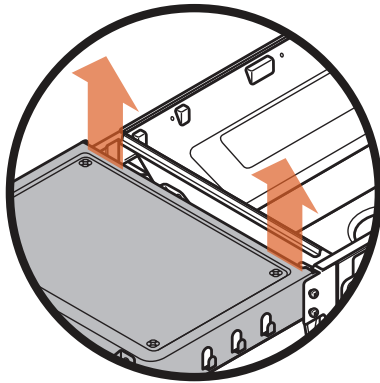
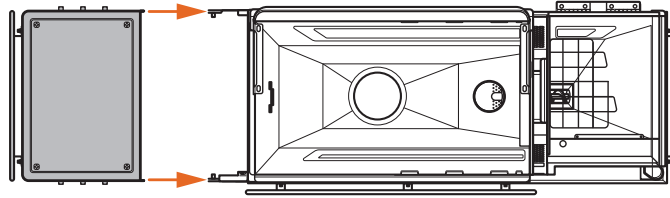
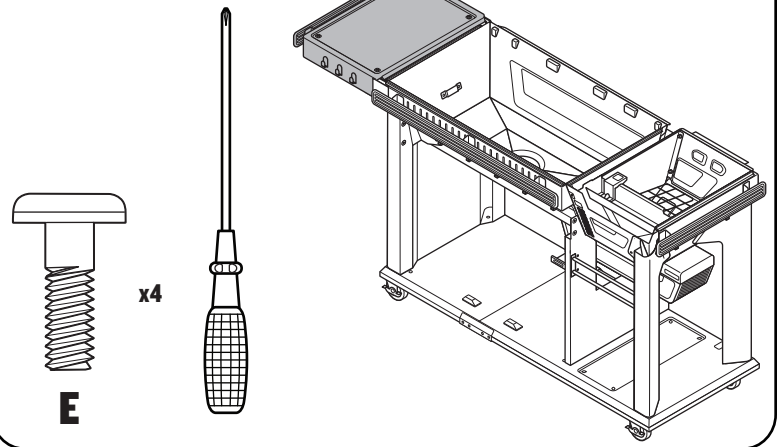

PRO TIP: Have a second person help position rear panels.

5 ASSEMBLE REAR PANELS AND TOP TRIM



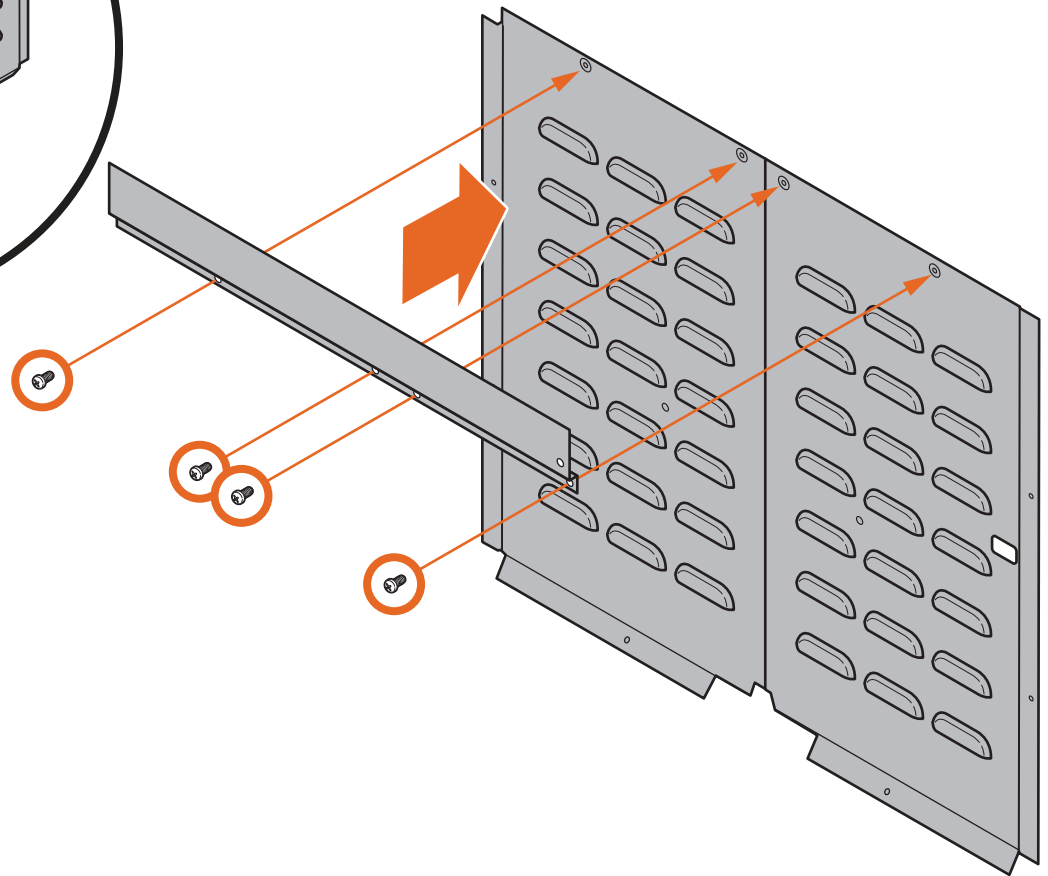
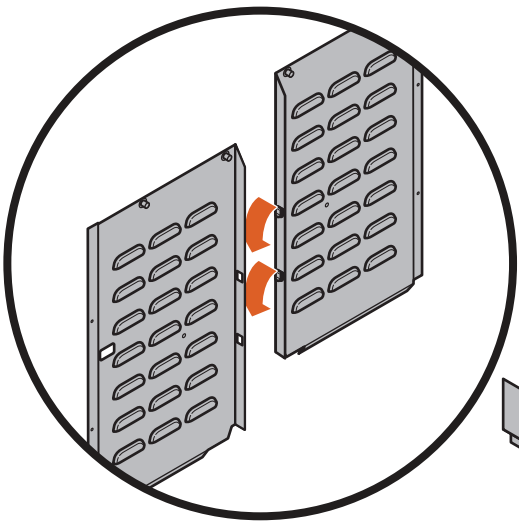
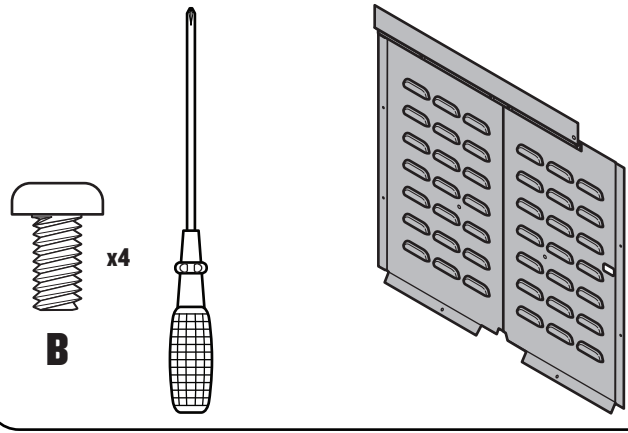

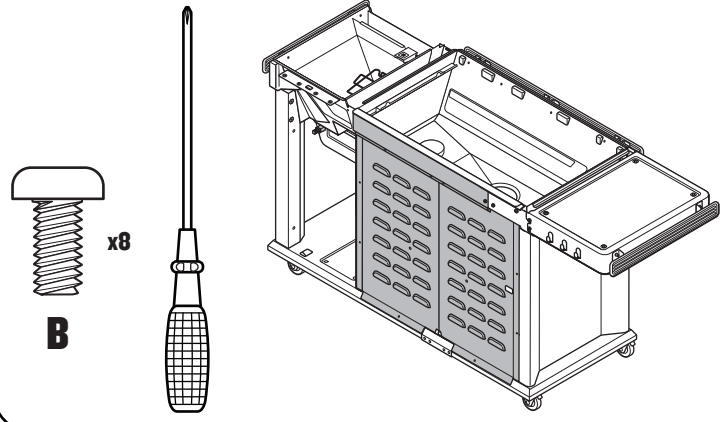

6 ATTACH REAR TOP TRIM/ REAR PANEL ASSEMBLY

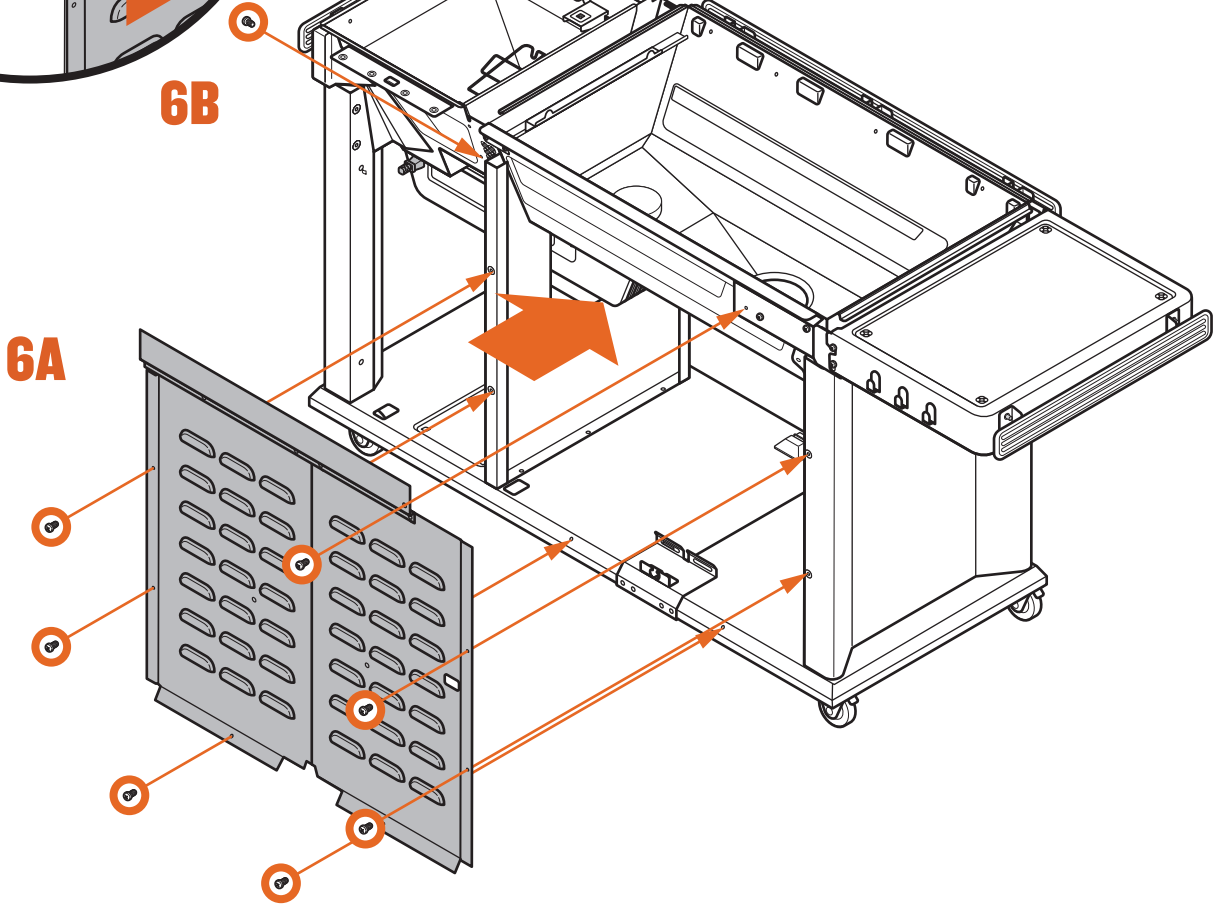

PRO TIP: Install the side screw last, pushing up on the rear panel while doing so.





 **PRO TIP:** This step requires no hardware.

7 ASSEMBLE BACKSPLASH

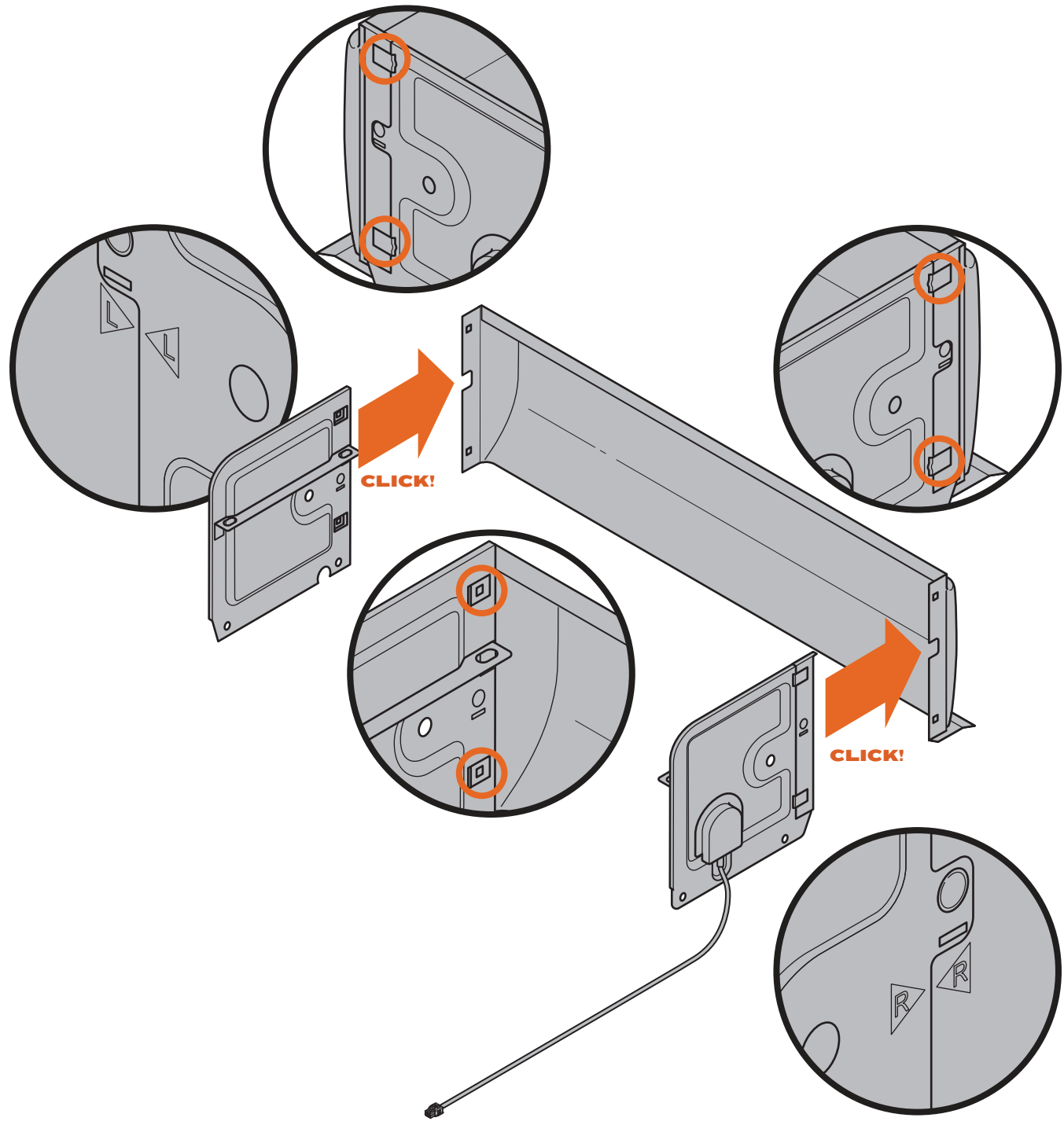
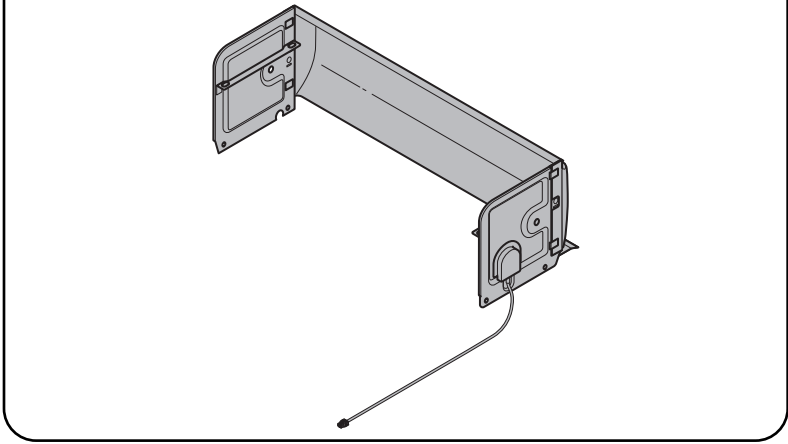



PRO TIP: Don't pinch the wire between the backsplash and the grill body! Also, slide the wire through the openings carefully to prevent damage!

8 ROUTE BACKSPLASH WIRING

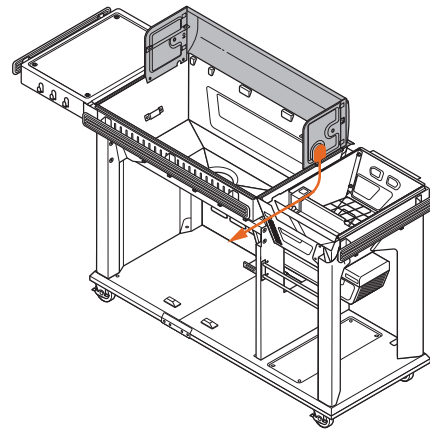

8A

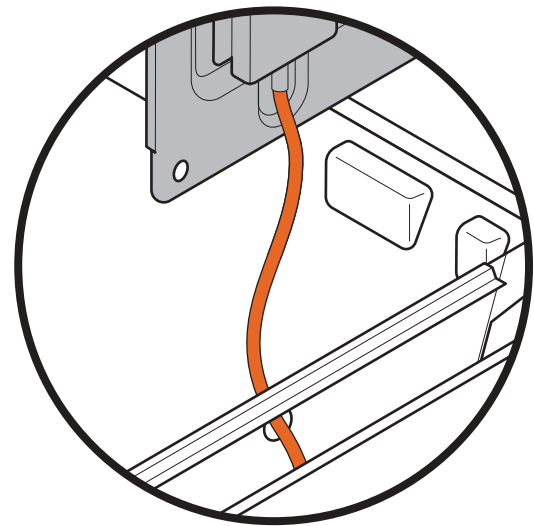
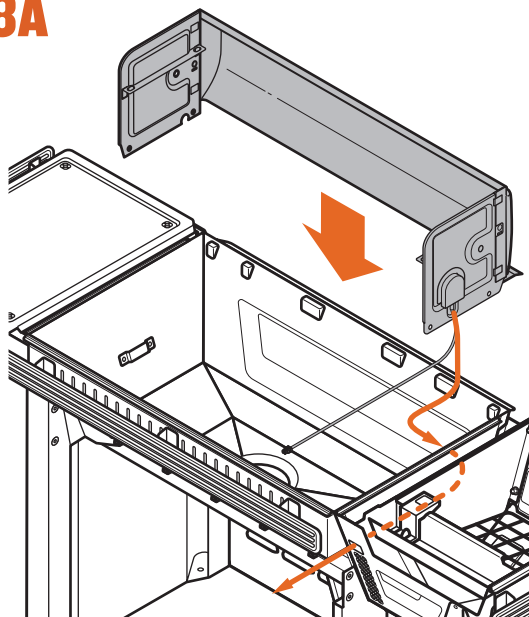

8B

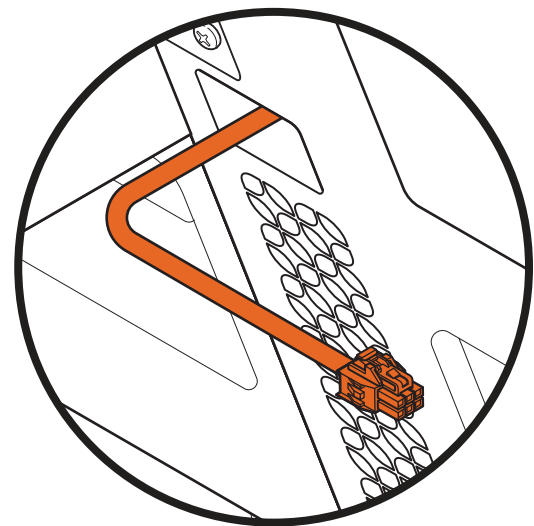
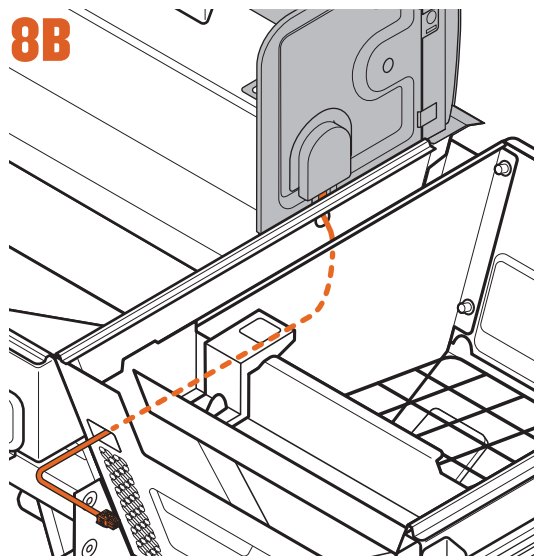



9 ATTACH BACKSPLASH

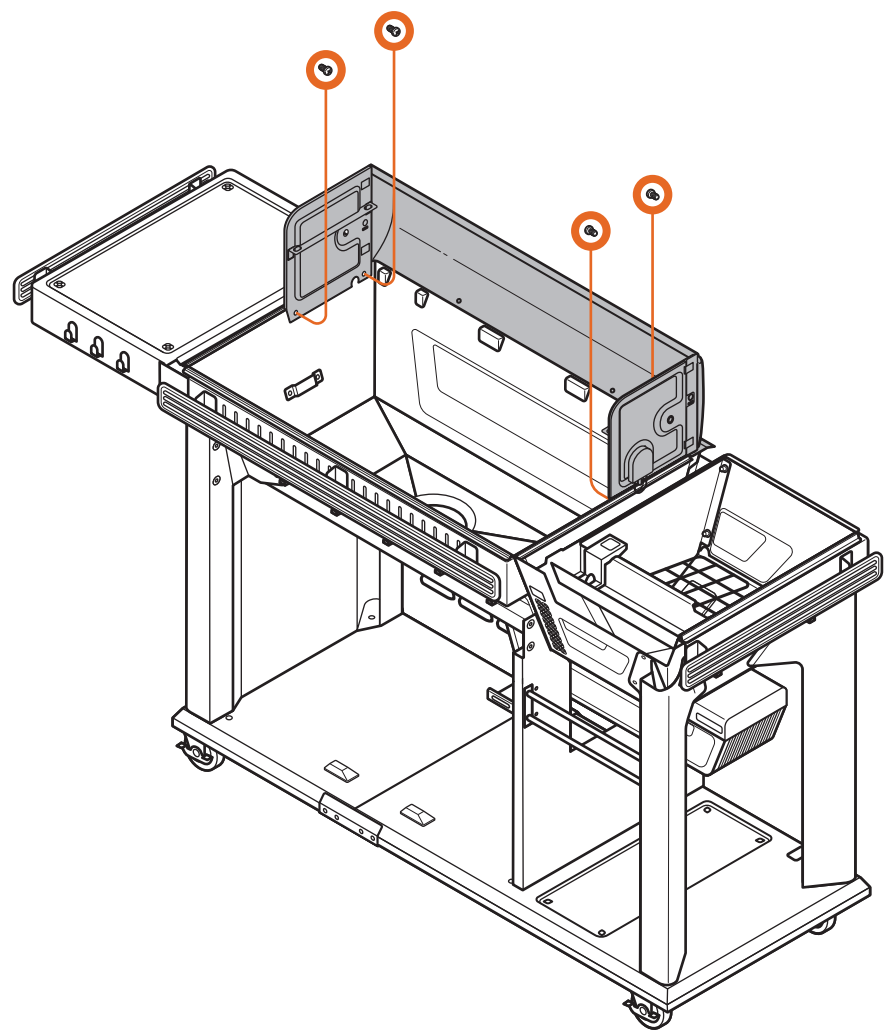
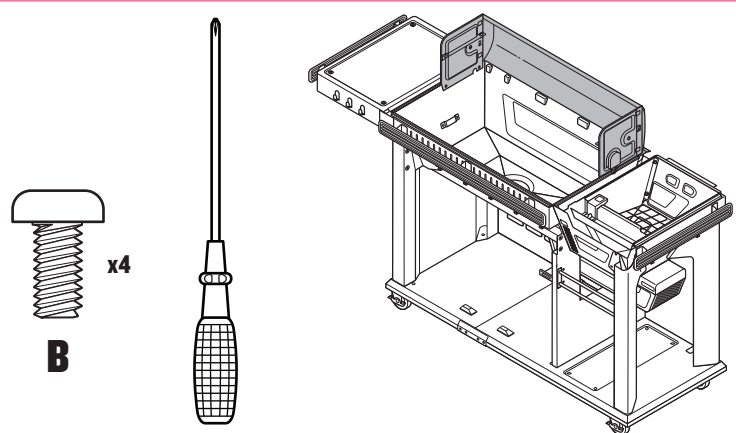



10 INSTALL REAR HOOKS

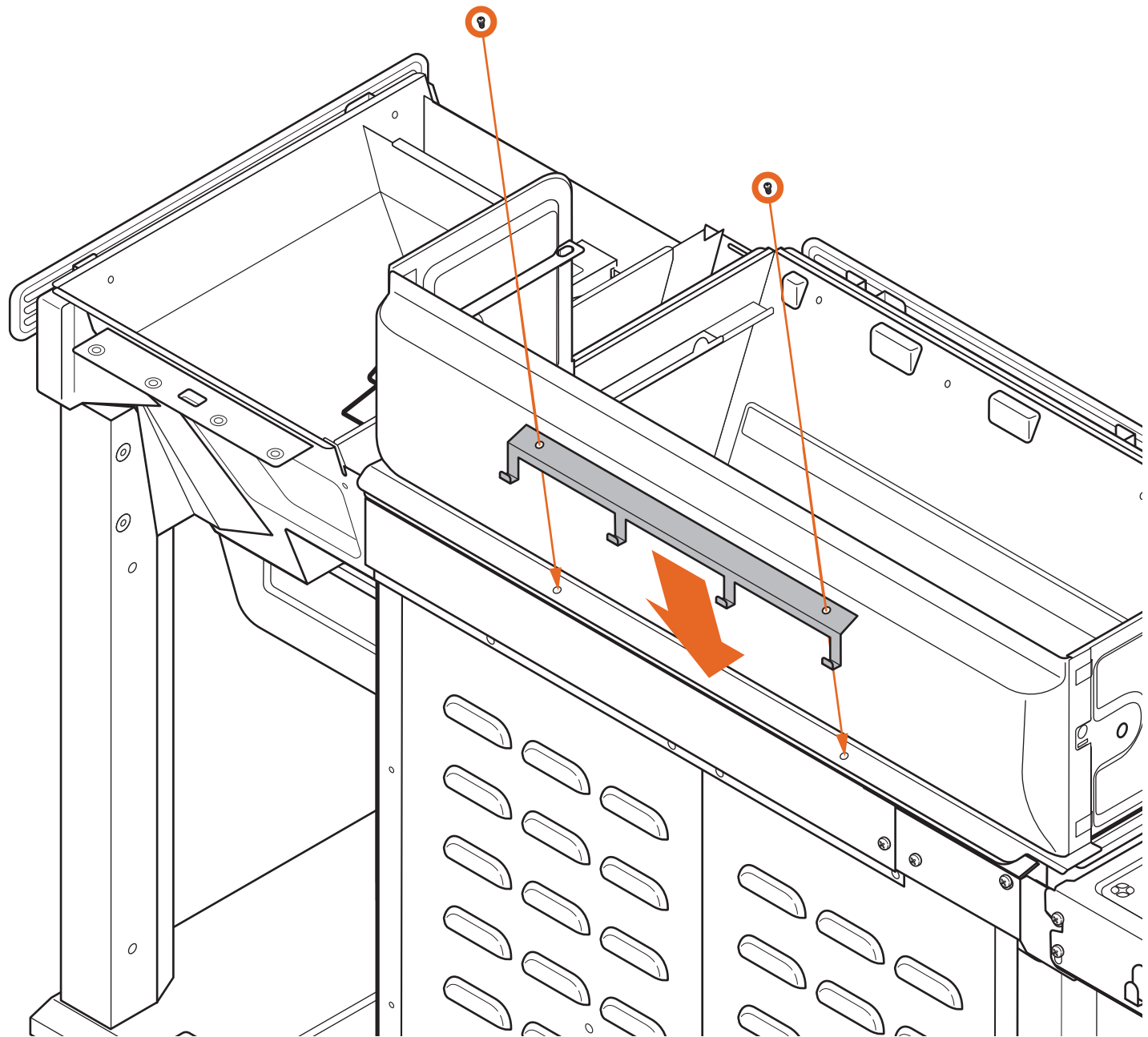
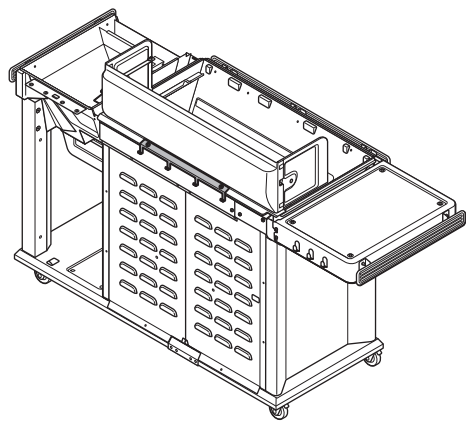
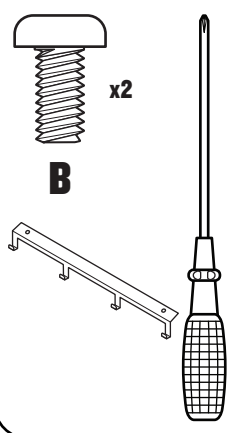



RTD SENSOR
4-PIN
CONNECTOR

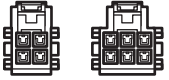

CONTROLLER
12-PIN
CONNECTOR



PELLET LEVEL
SENSOR 6-PIN
CONNECTOR

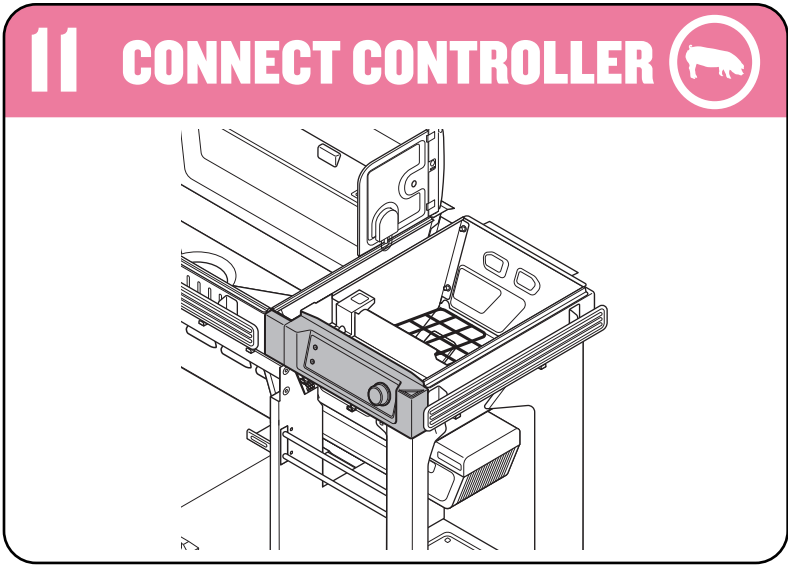
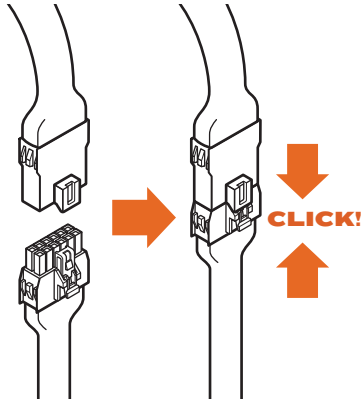

PRO TIP: For easier connecting, lay the controller on its back on the edge of the hopper.

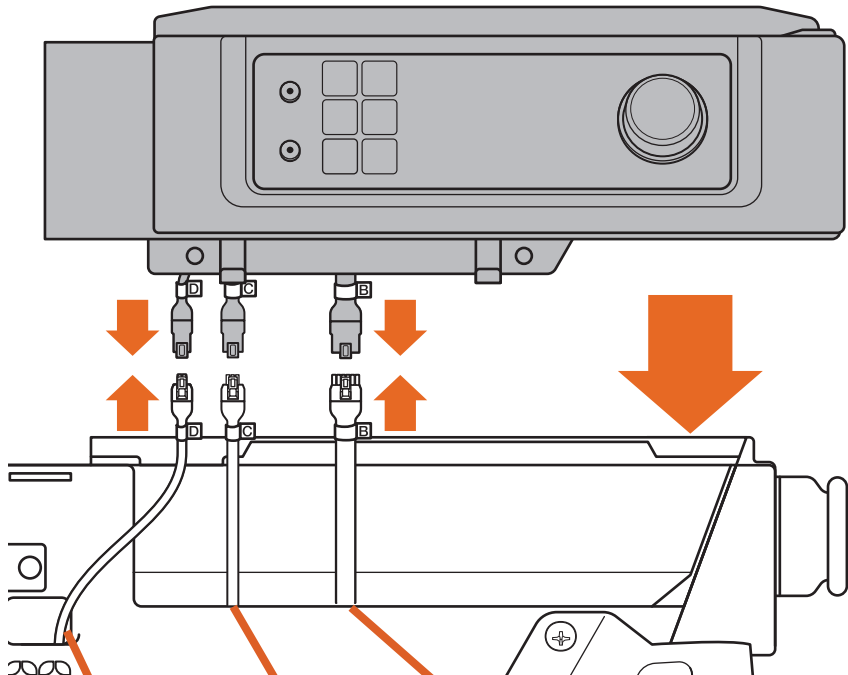
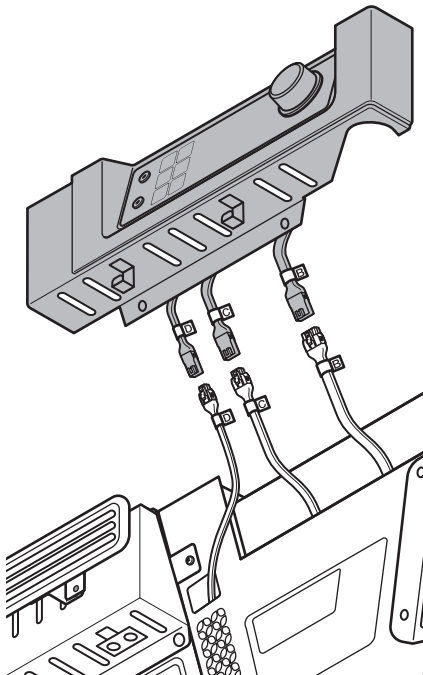

RTD SENSOR
4-PIN
CONNECTOR

PELLET LEVEL
SENSOR 6-PIN
CONNECTOR

CONTROLLER
12-PIN
CONNECTOR



PRO TIP: After connecting, tuck wires back into grill to prevent pinching them.



12A ATTACH CONTROLLER

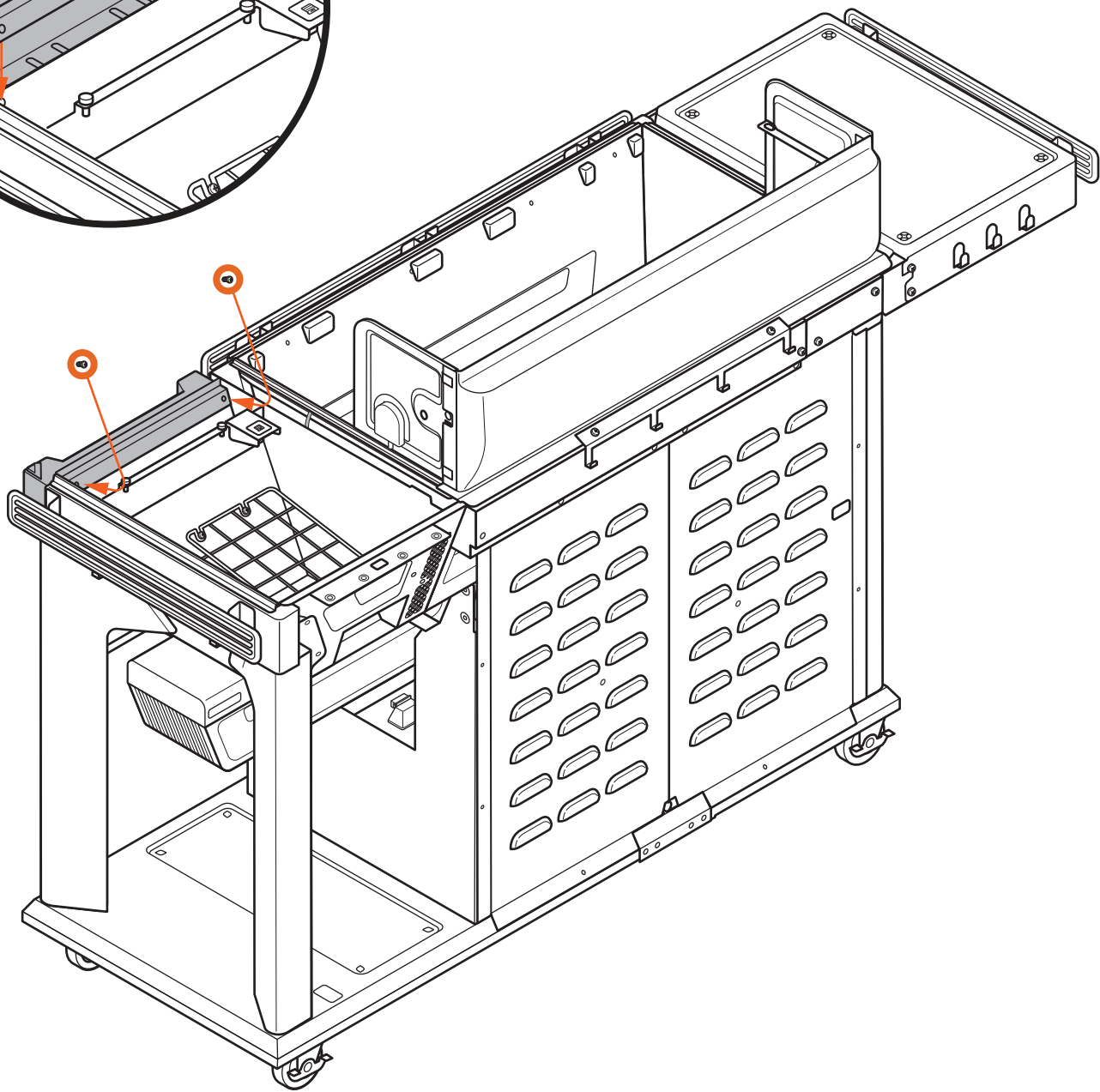
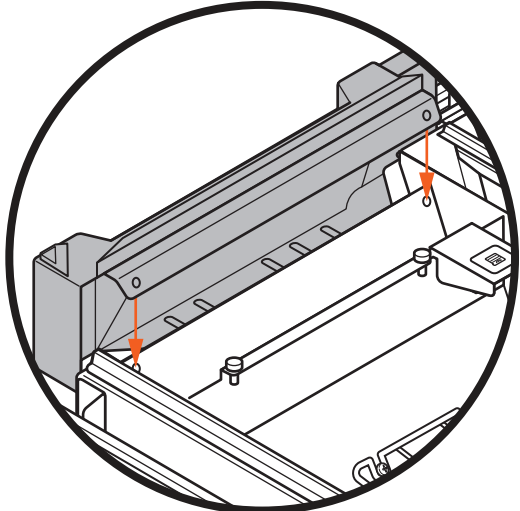
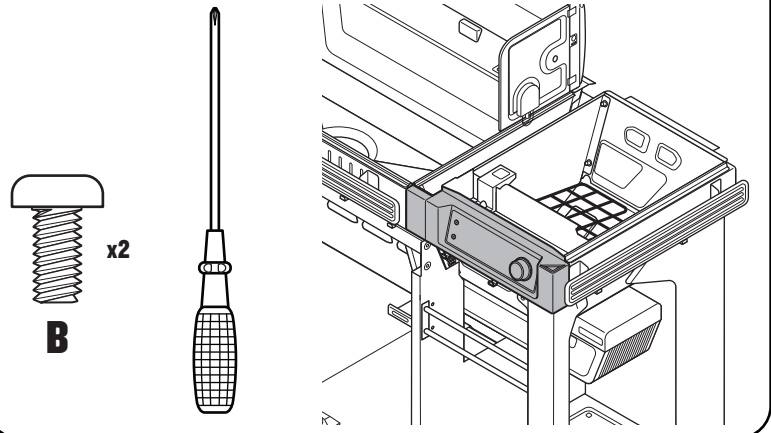

12B ATTACH CONTROLLER

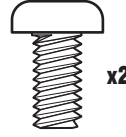

x2

B

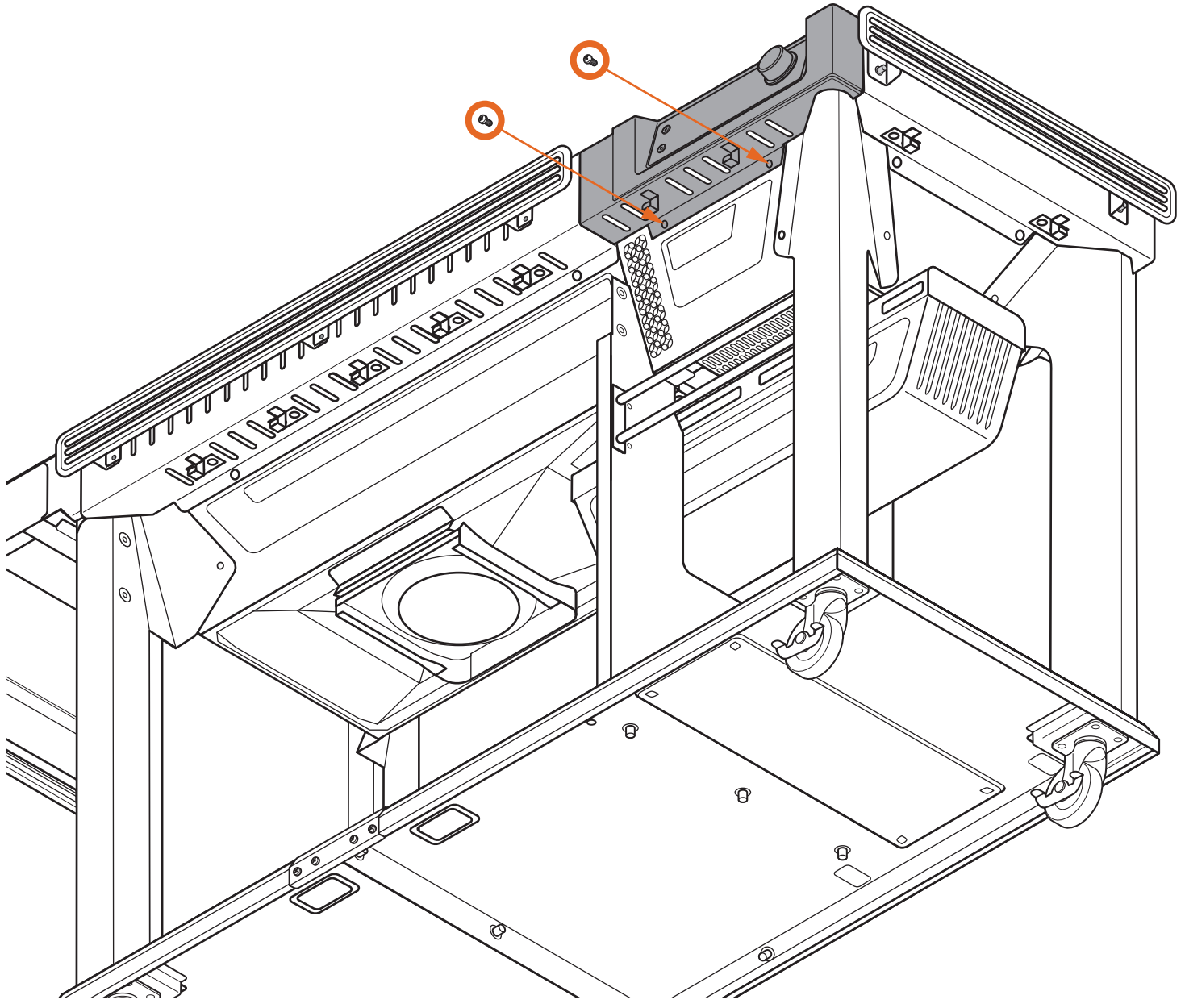
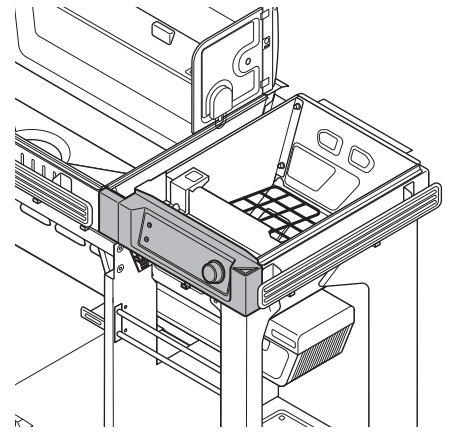



13 ATTACH FRONT TRIM

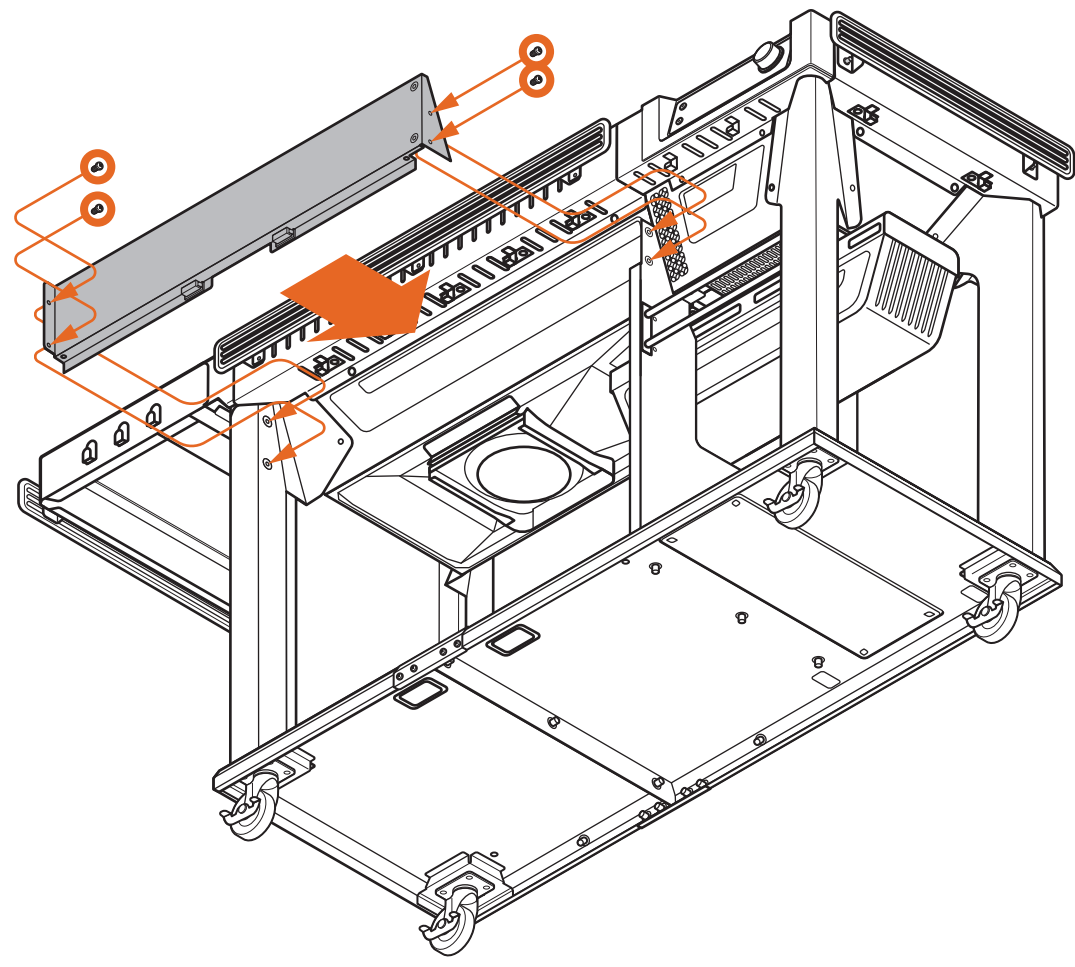
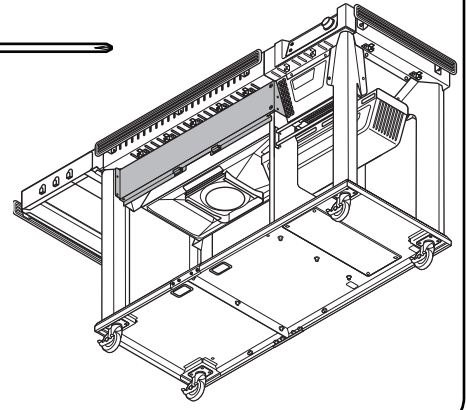
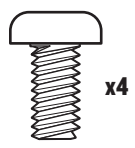
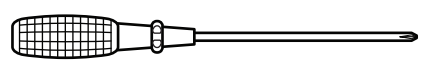



14 ATTACH FRONT RIGHT TRIM

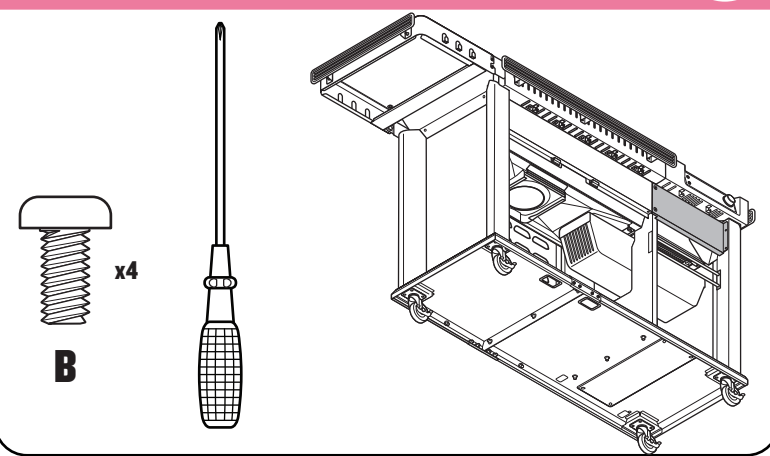

B x4

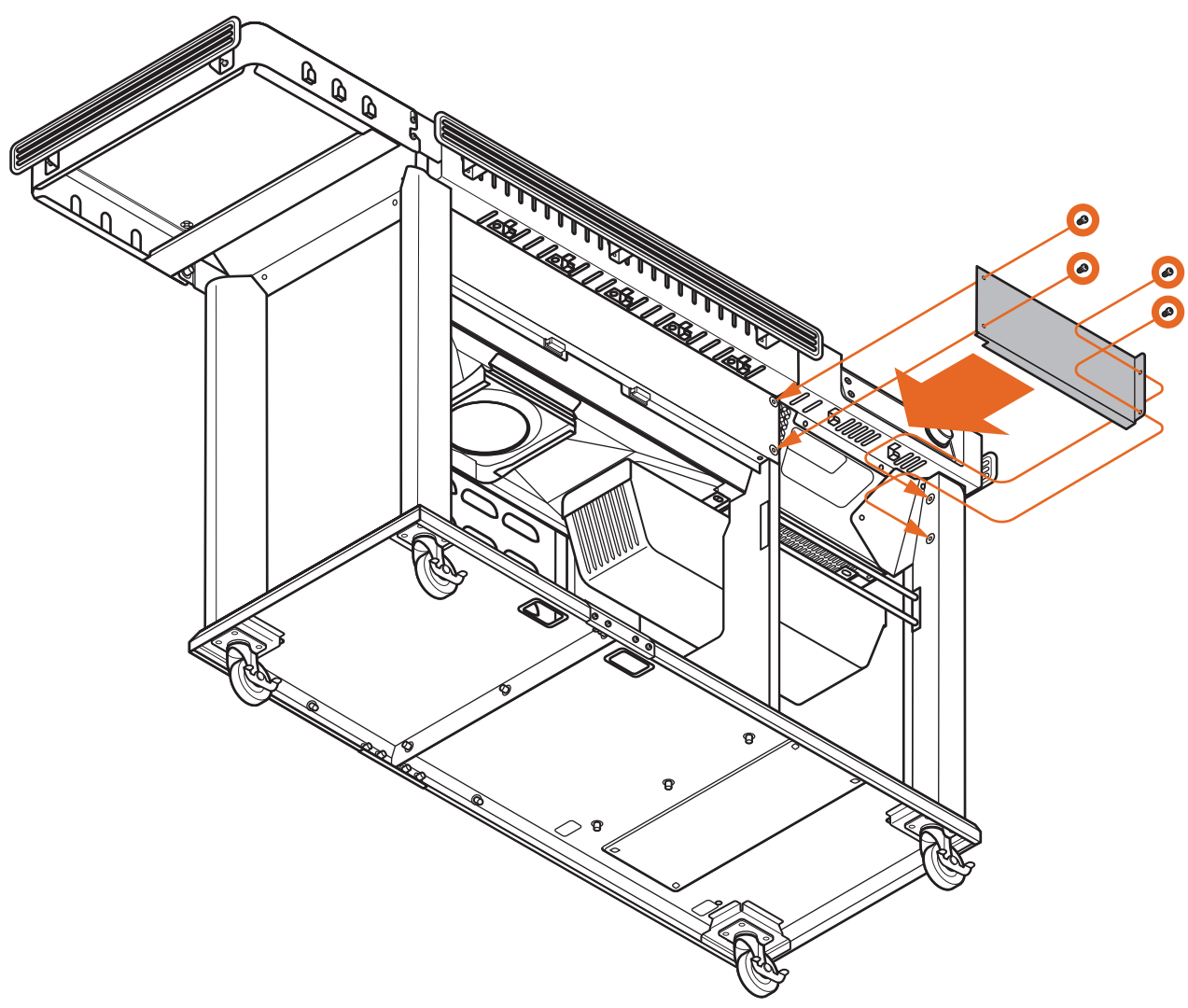



15 ATTACH DOORS

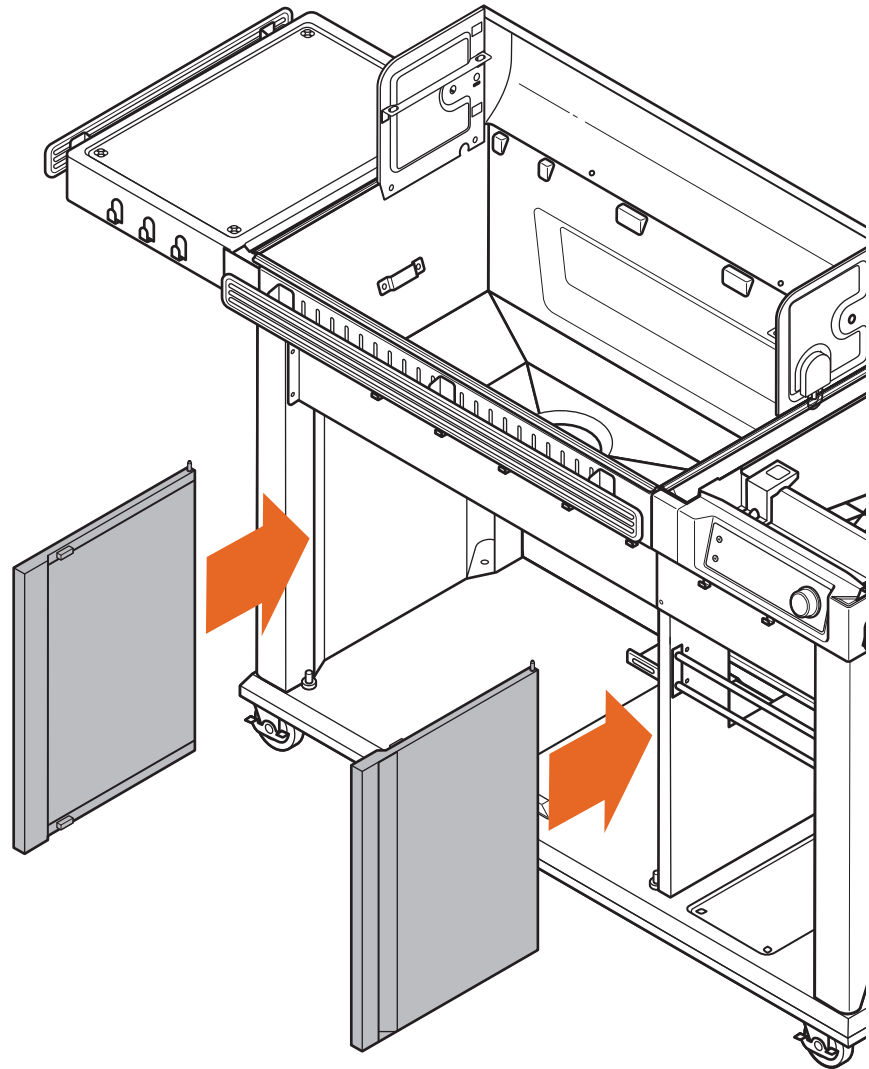
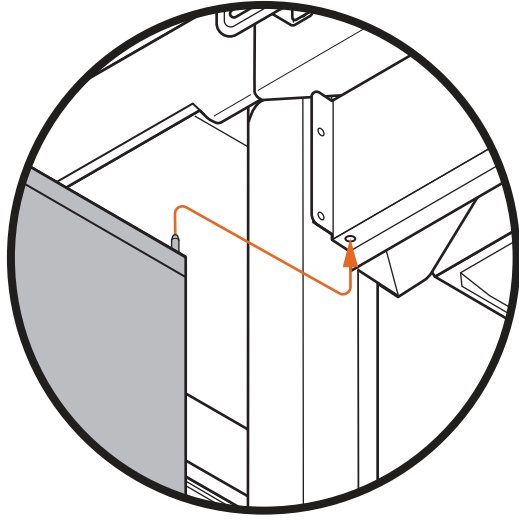
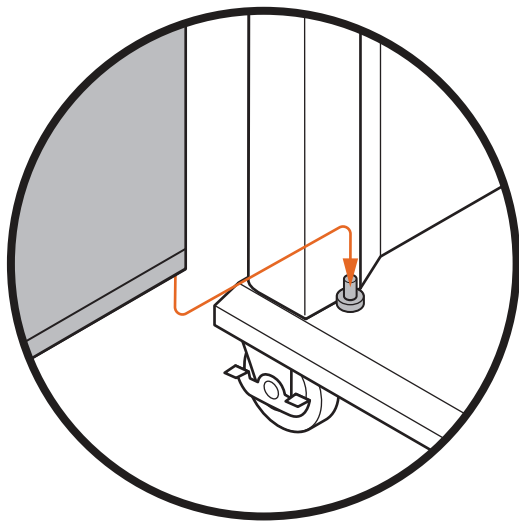
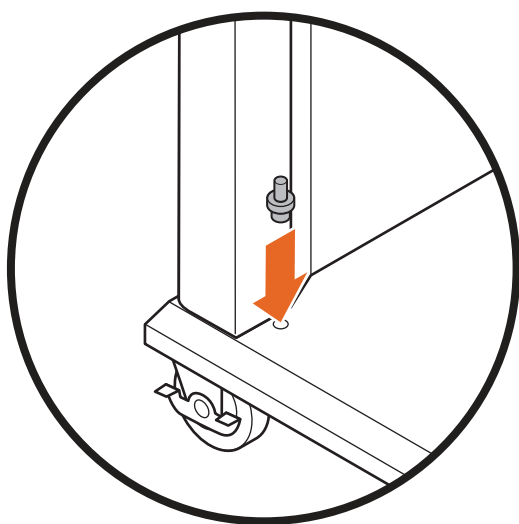
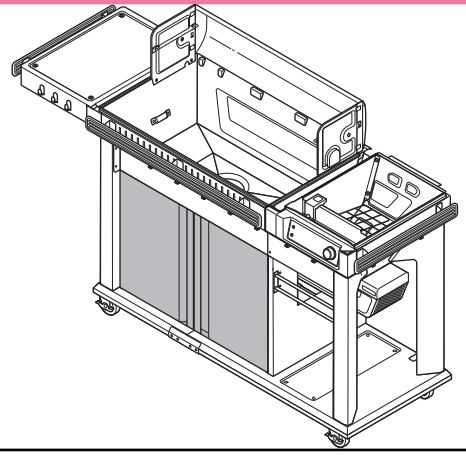
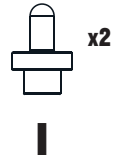



16 ATTACH TRIM BAND

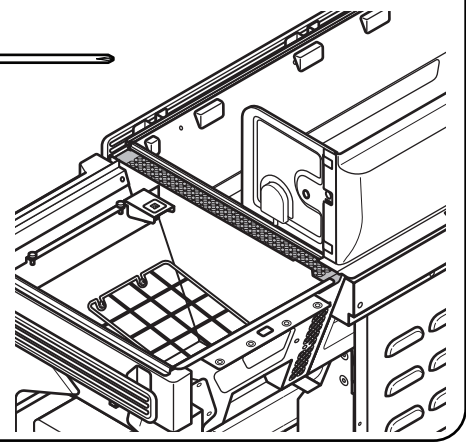
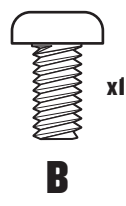
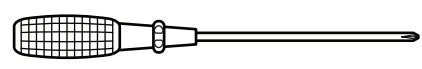

16A

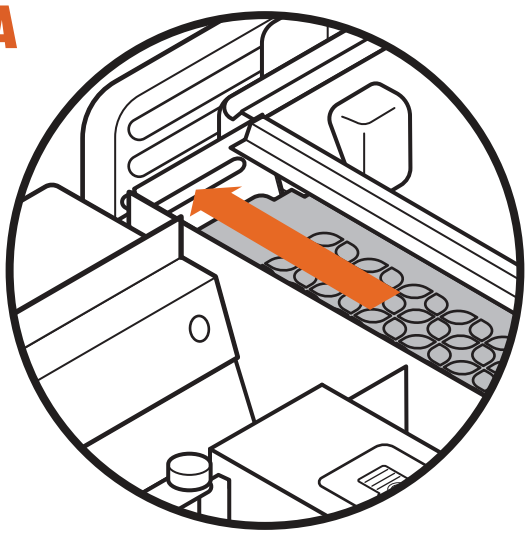

16B

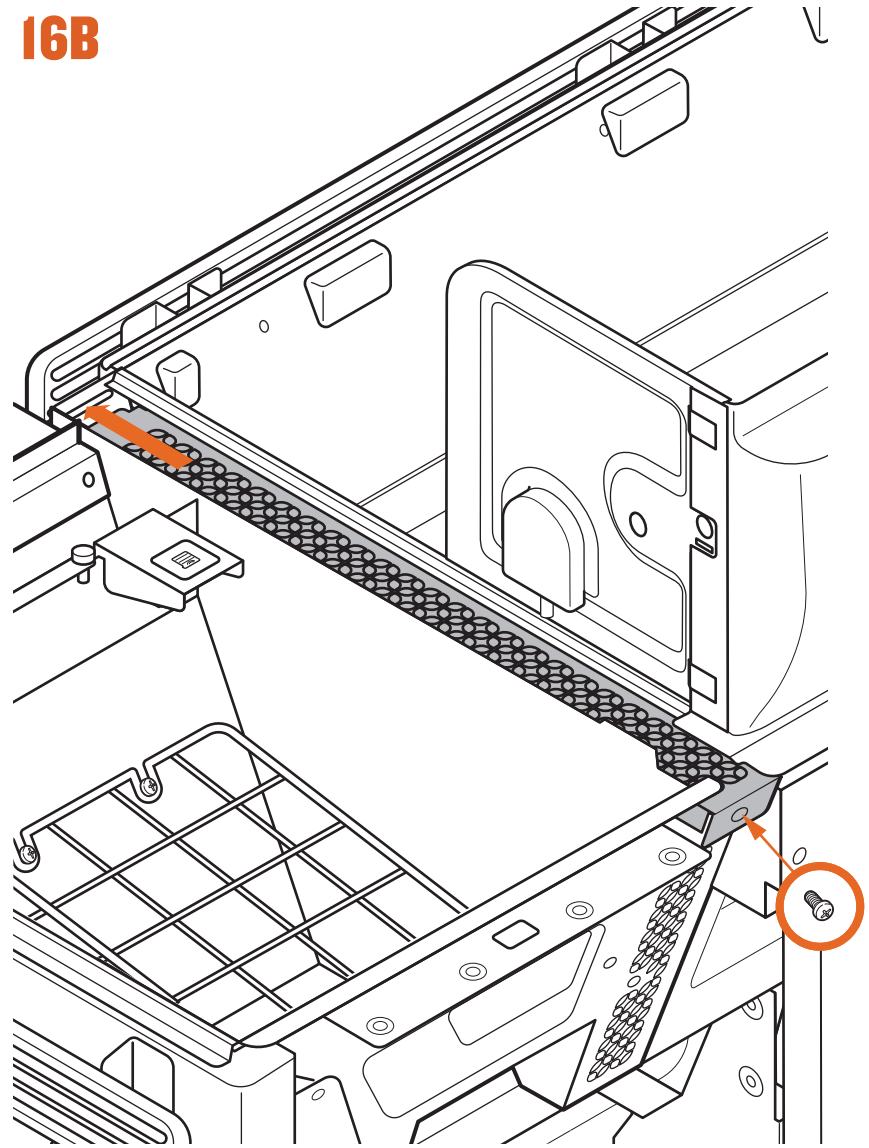

**NICE WORK!
CHAPTER 3 COMPLETE!**

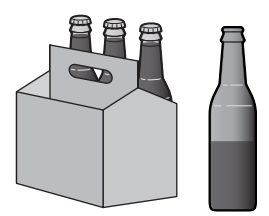

CHAPTER 4

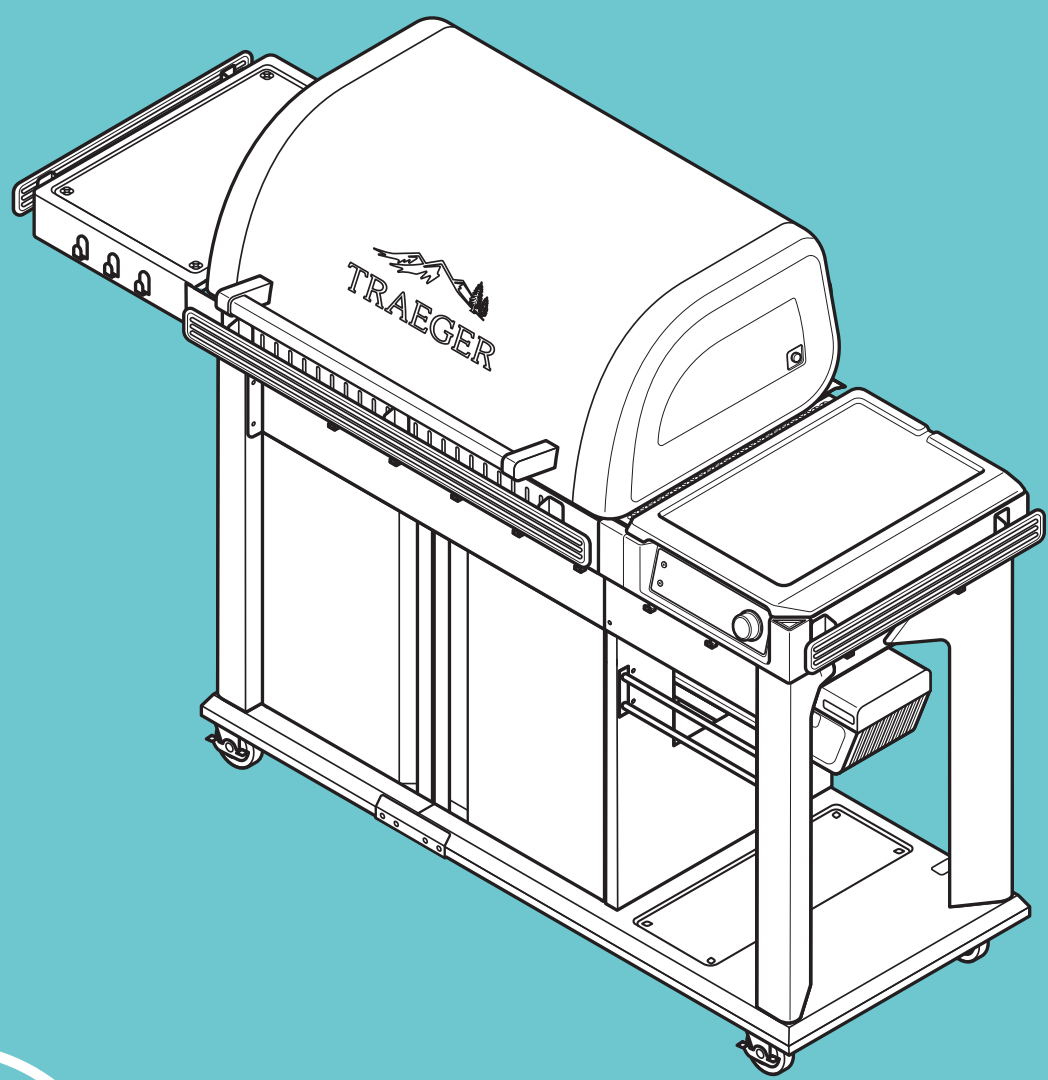

LID & GRILL INTERNALS

CHAPTER 4

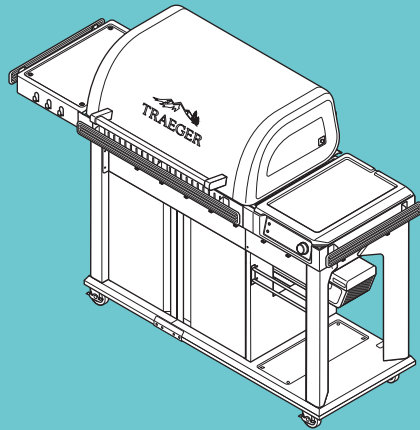

1 ATTACH HOPPER LID

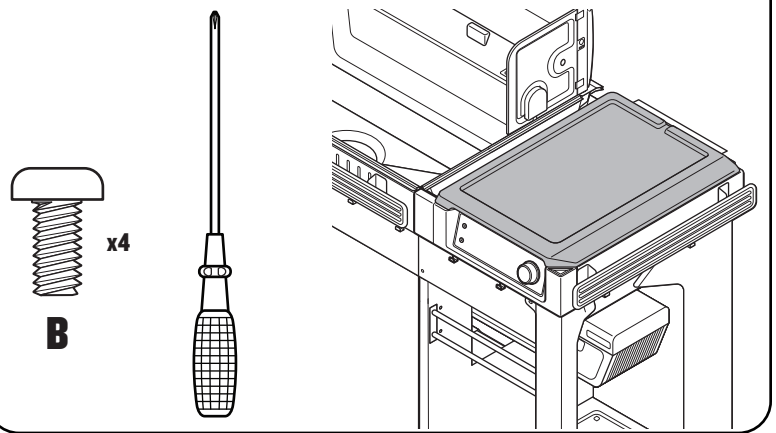

PRO TIP: Hand-tighten all screws first, then finish tightening with screwdriver.

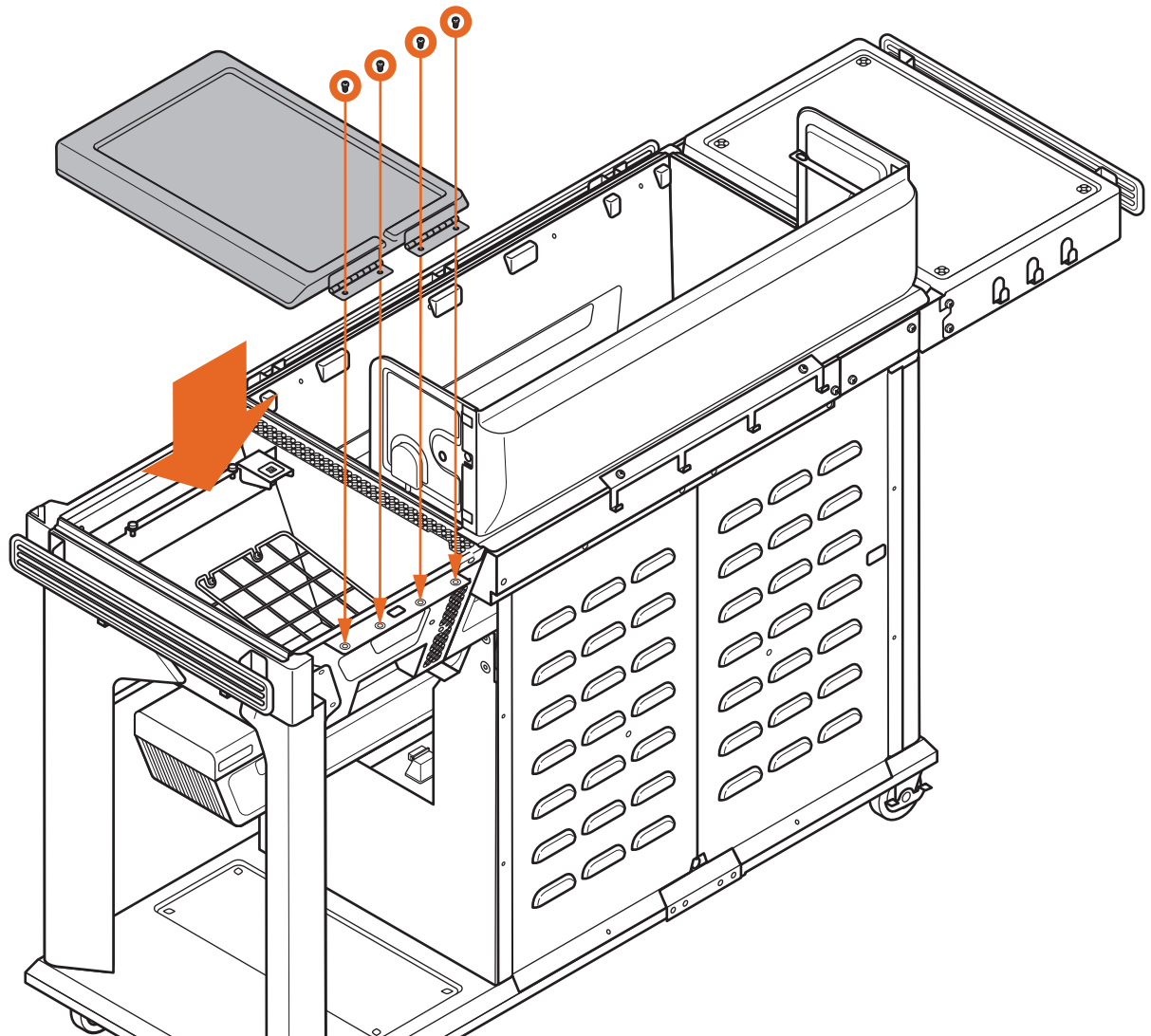



2 INSTALL CHUTE, SHIELD, AND BAFFLE

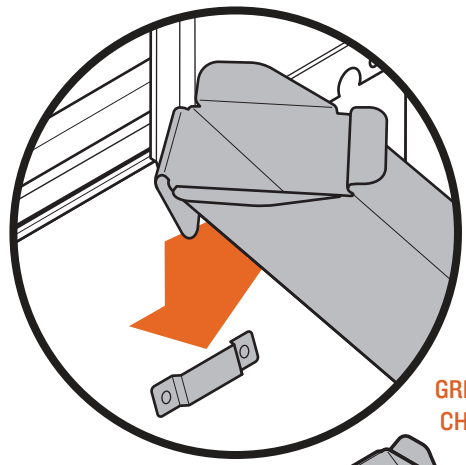
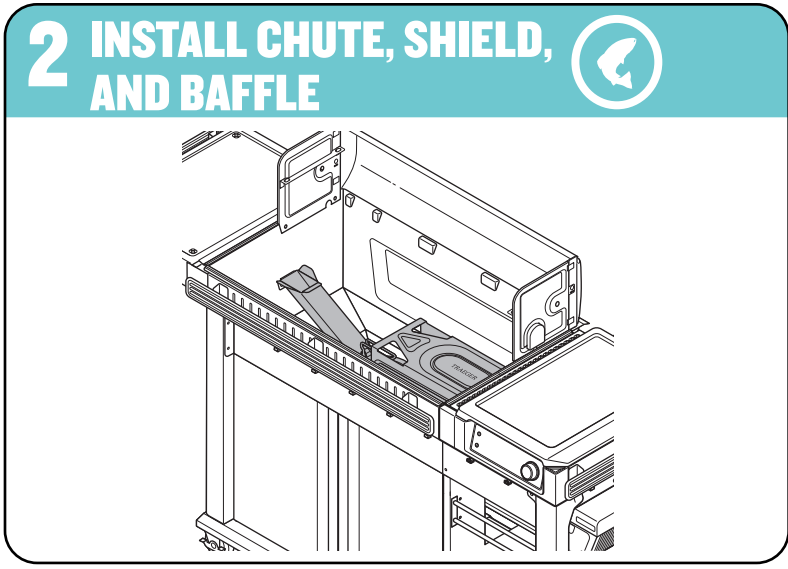
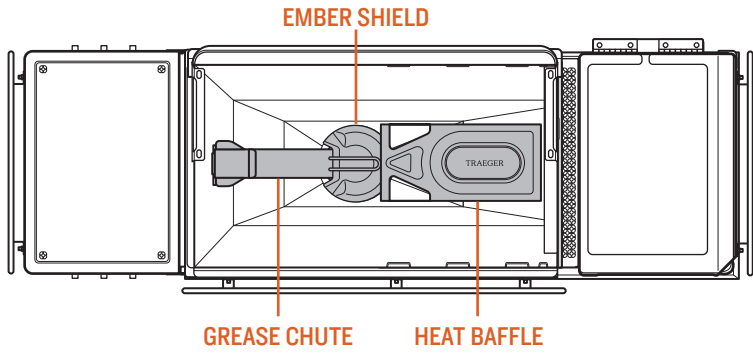

GREASE CHUTE

EMBER SHIELD

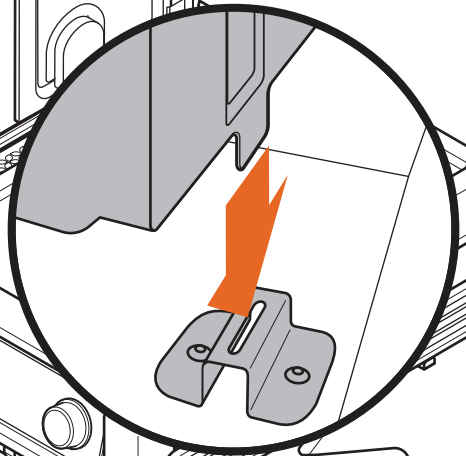
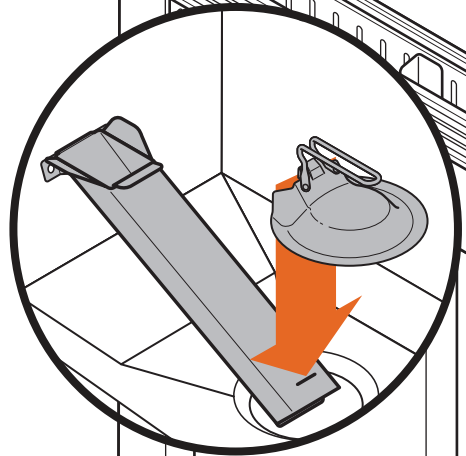
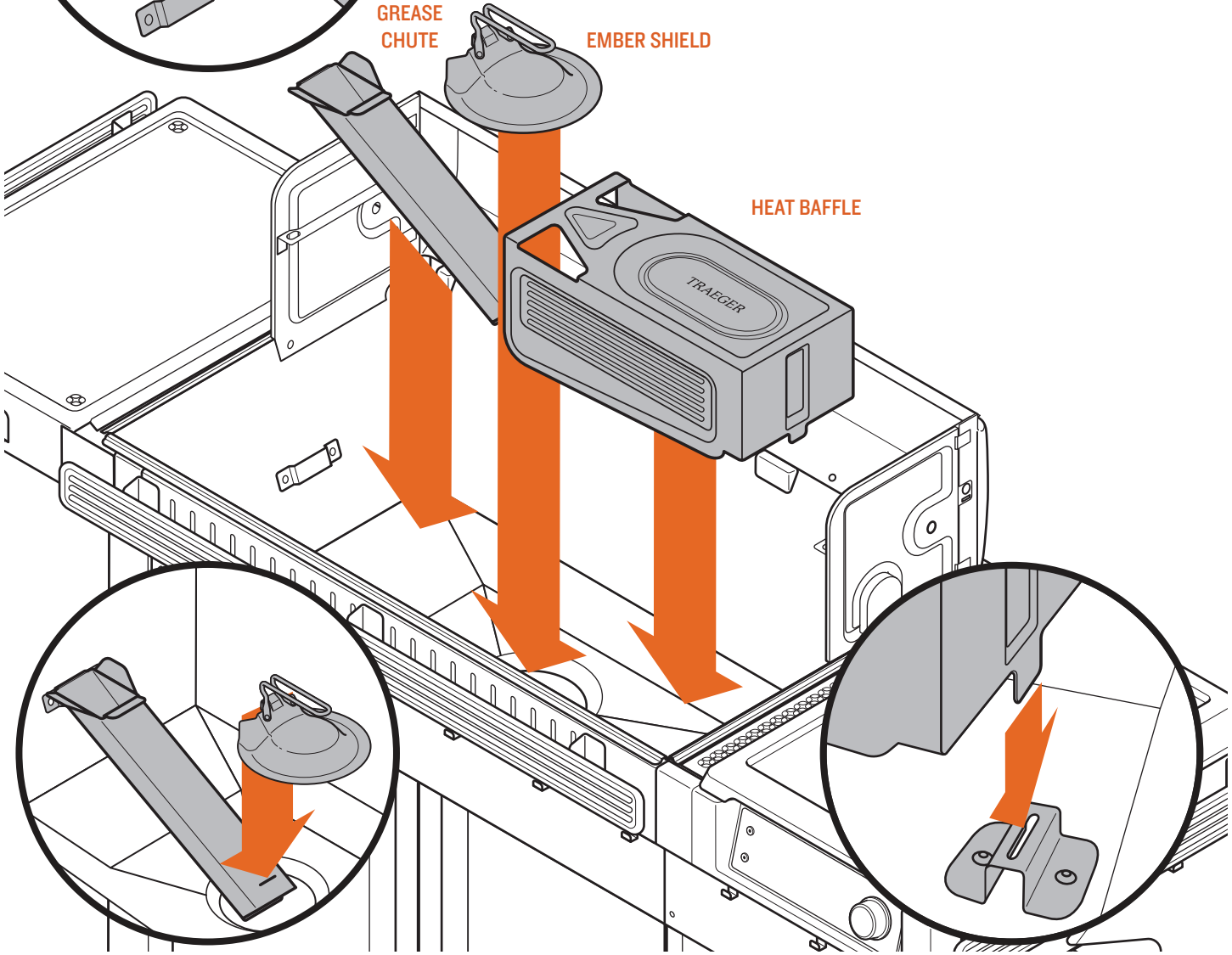



3 INSTALL DRIP TRAY

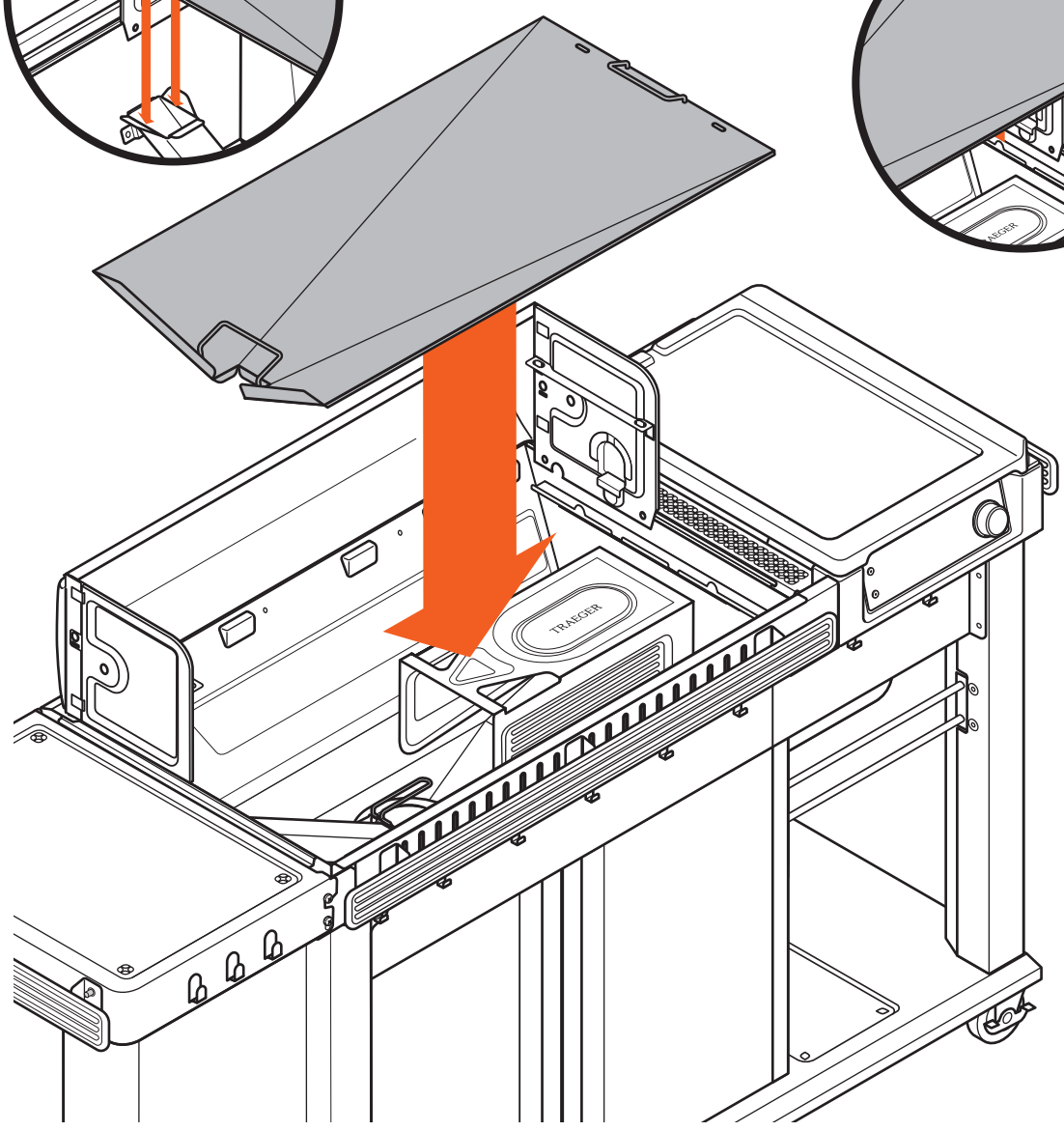
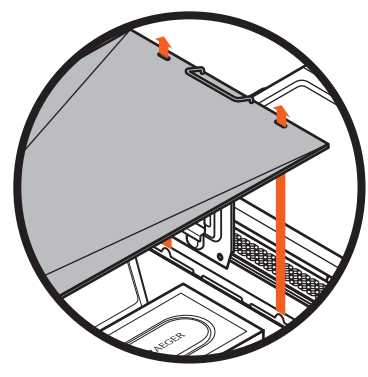
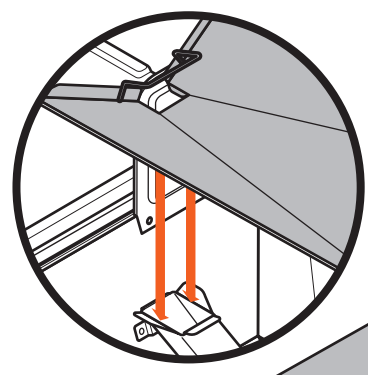
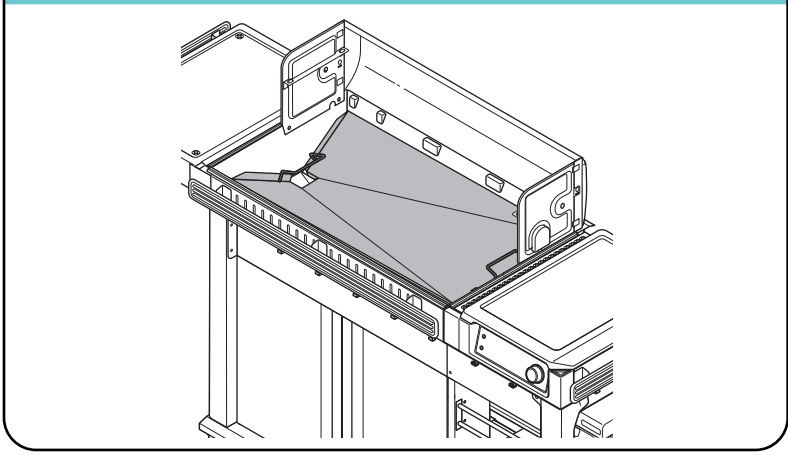



4A ATTACH LID HANDLE

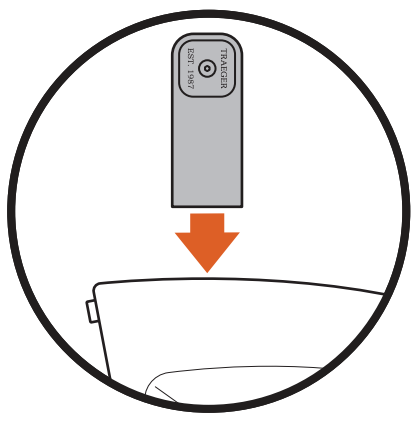
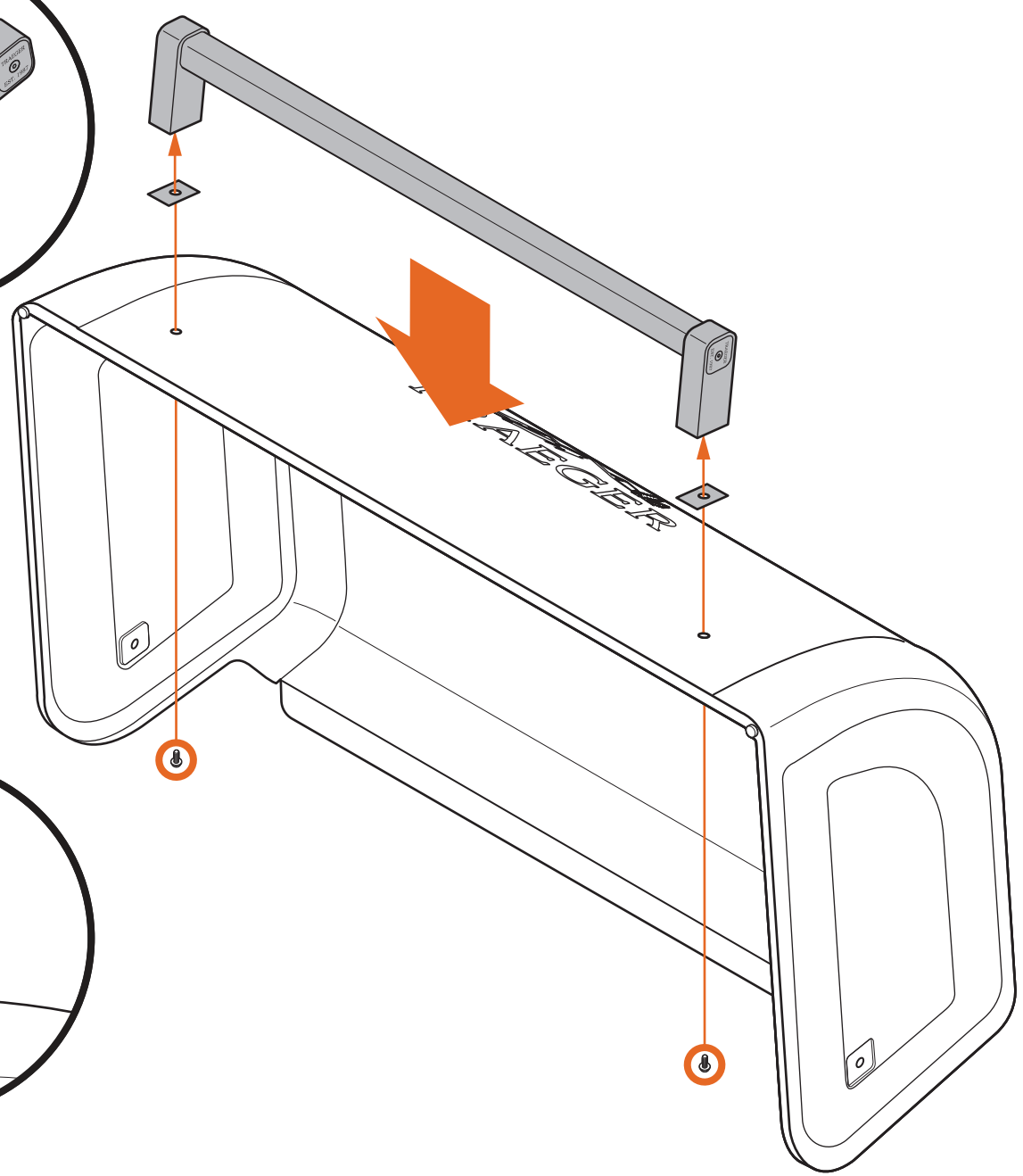
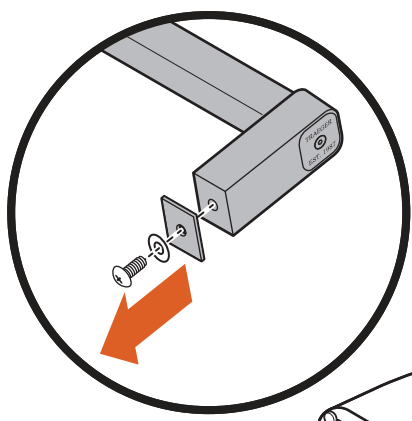
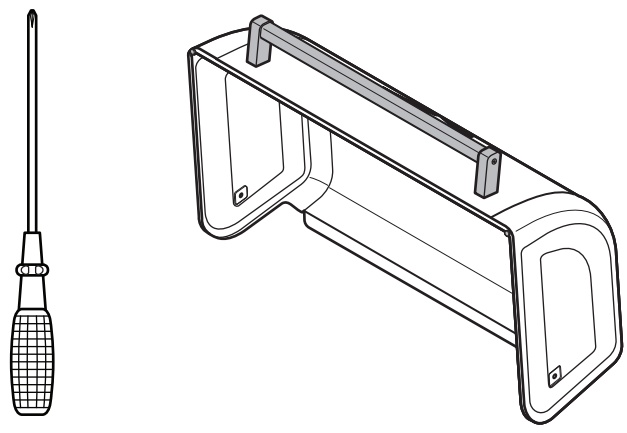



 **PRO TIP:** Use two people to attach the lid.

4B ATTACH LID

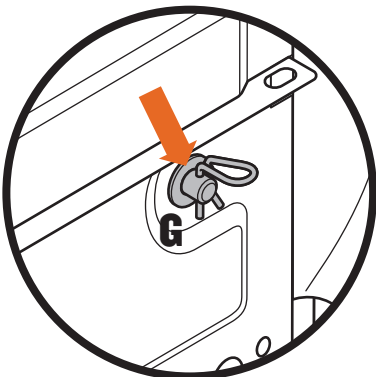
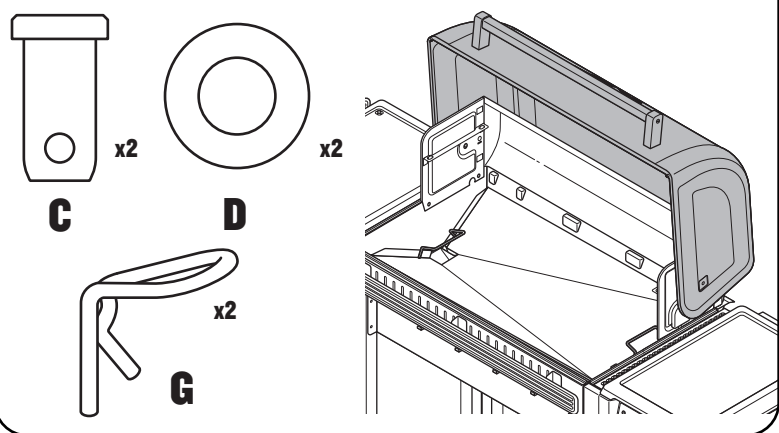

 **PRO TIP:** Attach clevis pins C with lid closed, then open lid to install G and D.

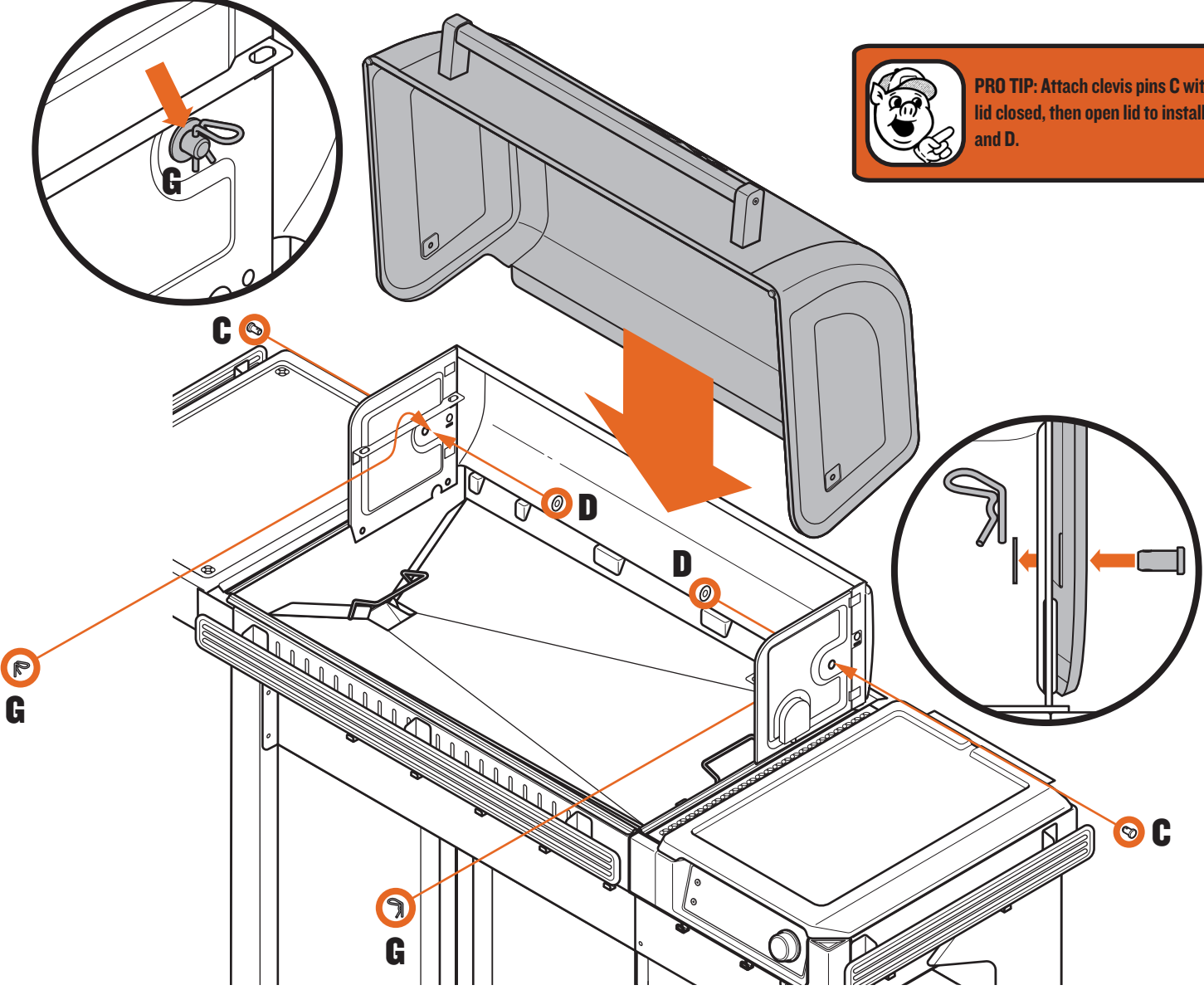



5 INSTALL GRATES

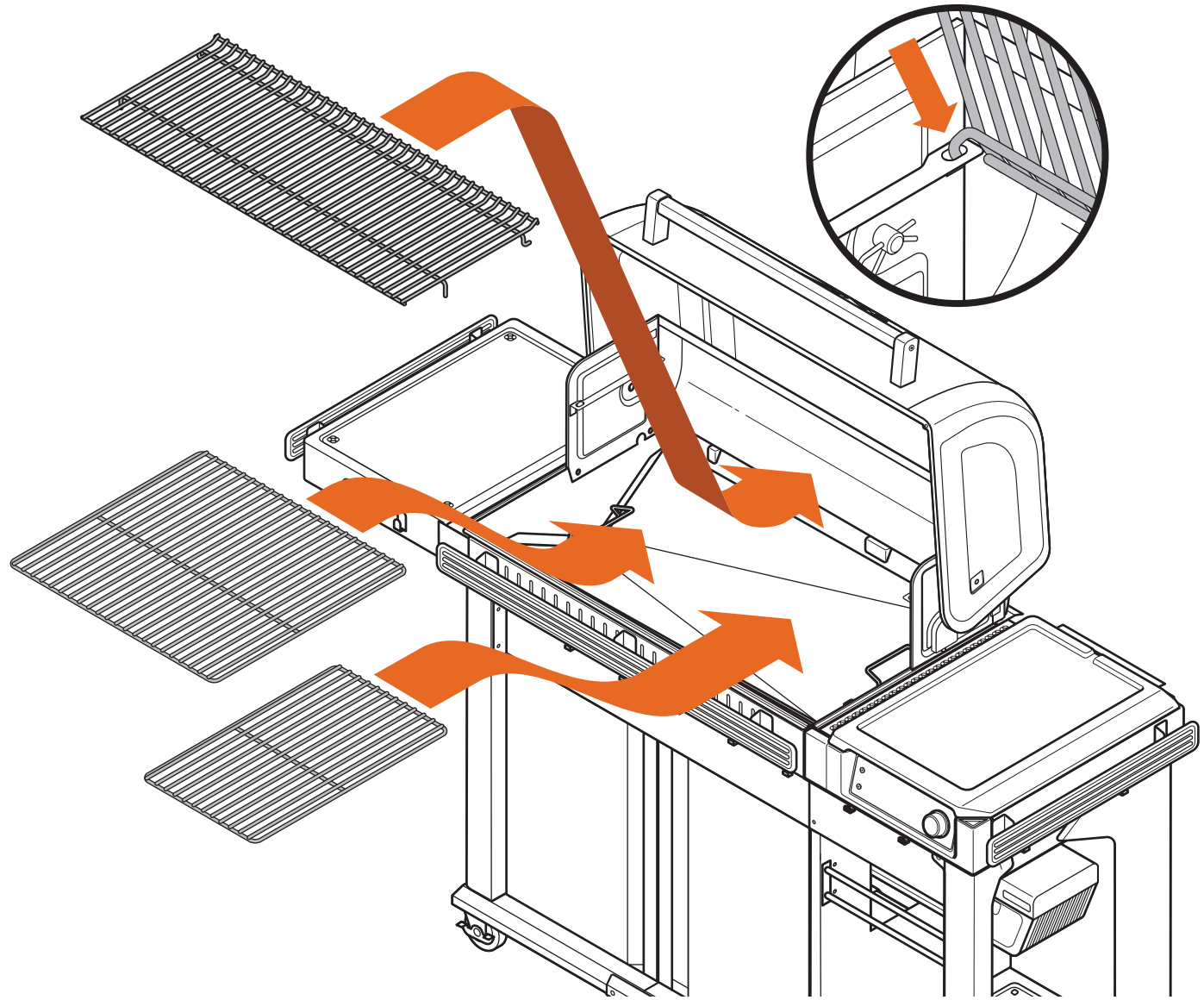
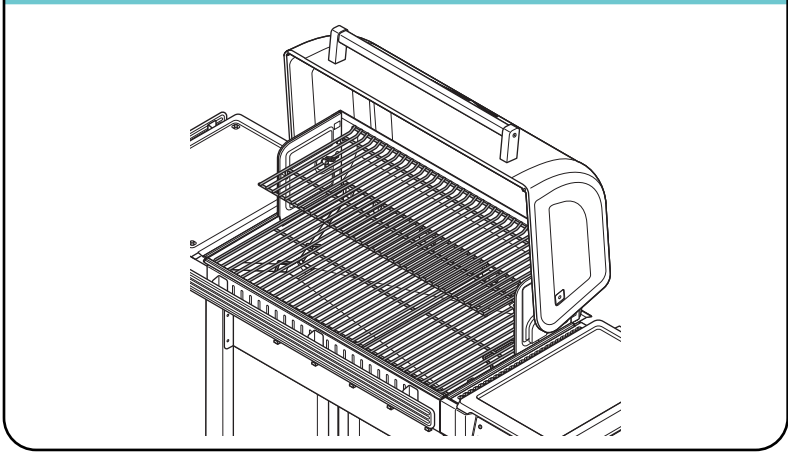



6 INSTALL GREASE & ASH KEG

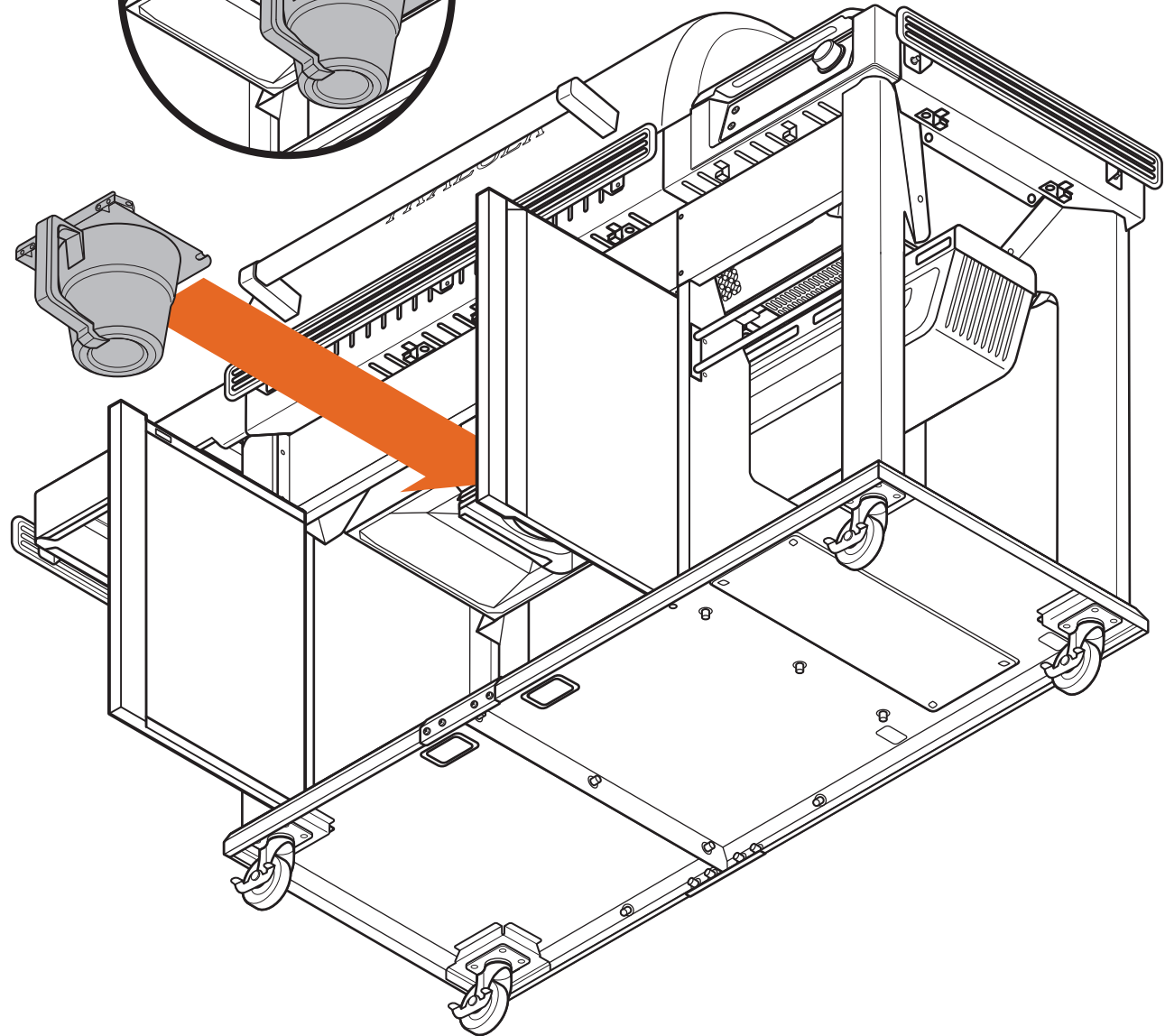
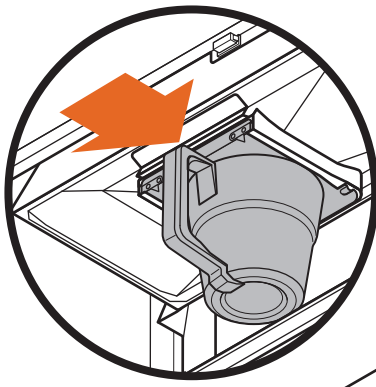
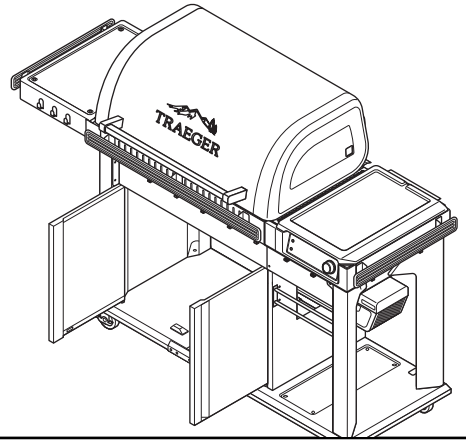

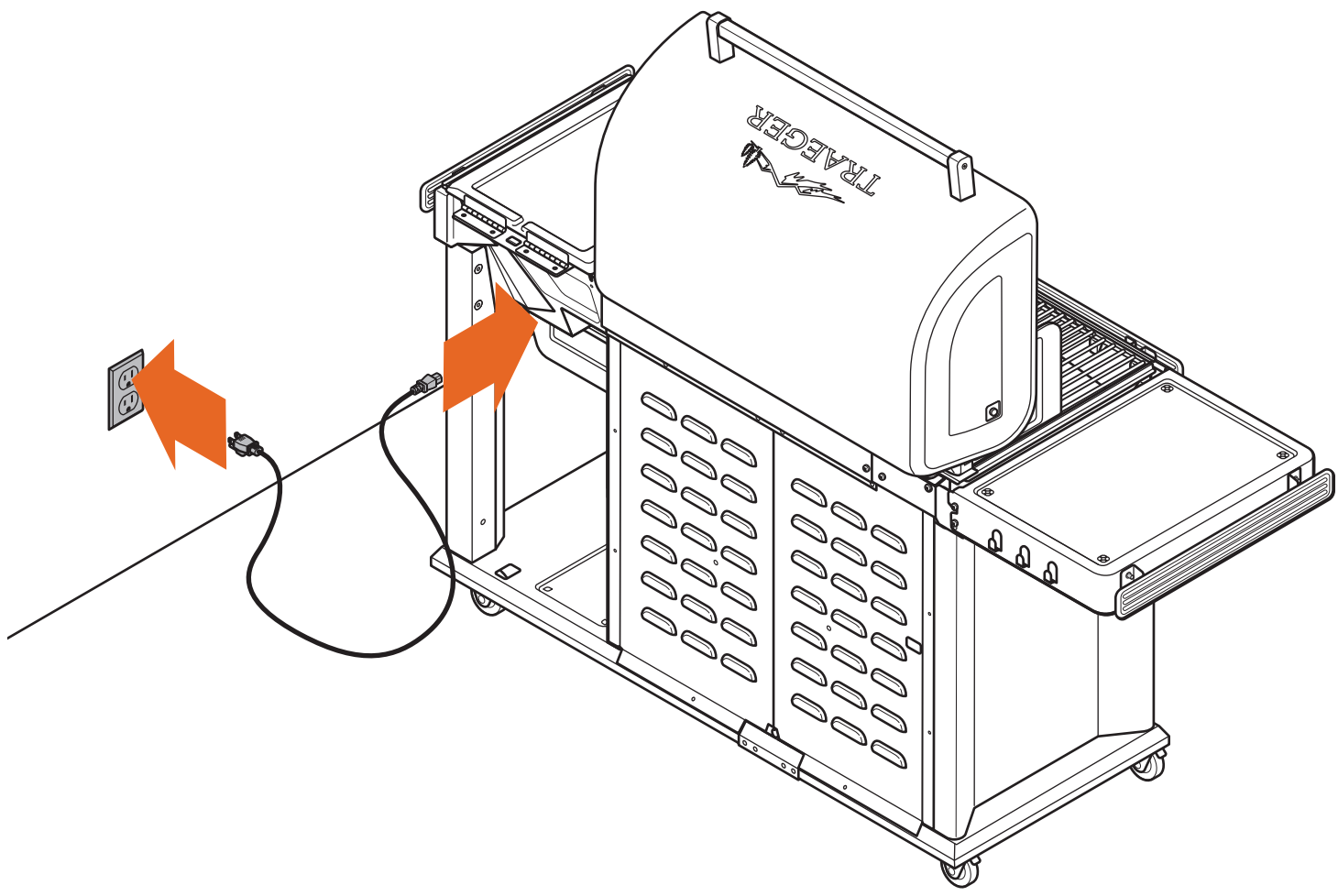
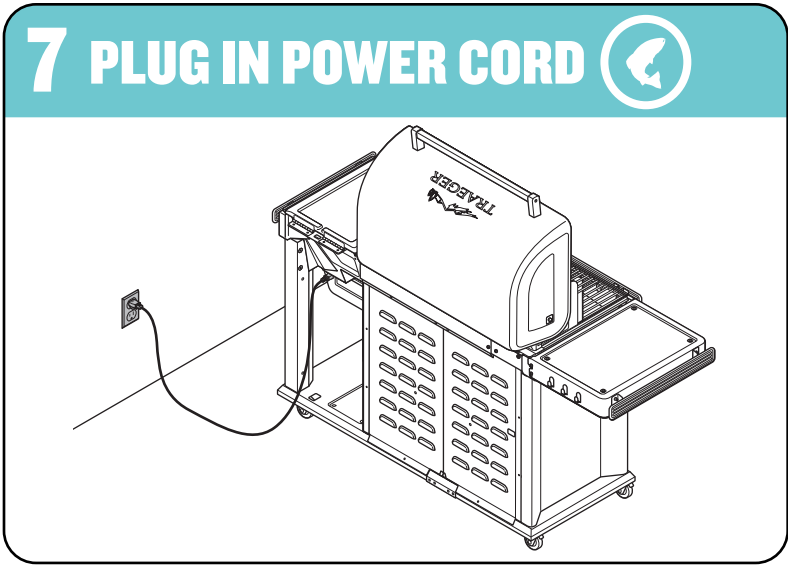

NICE WORK!
CHAPTER 4 COMPLETE!

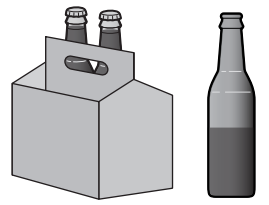

STORING PARTS AND ACCESSORIES



WARNING! DO NOT PUT A GRILL COVER OR ANYTHING FLAMMABLE IN THE STORAGE SPACE UNDER THE GRILL.

Wired Probe and Power Cord

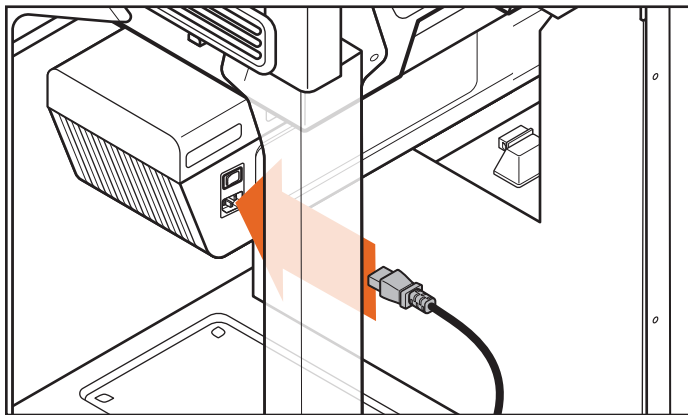
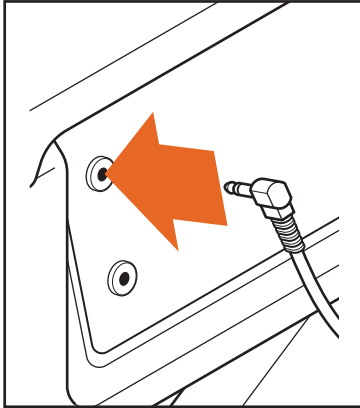

TO STORE (AFTER EVERY COOK):



Grill Grates, Drip Tray, Grease Chute, and Ember Shield

TO STORE DURING CLEANING:

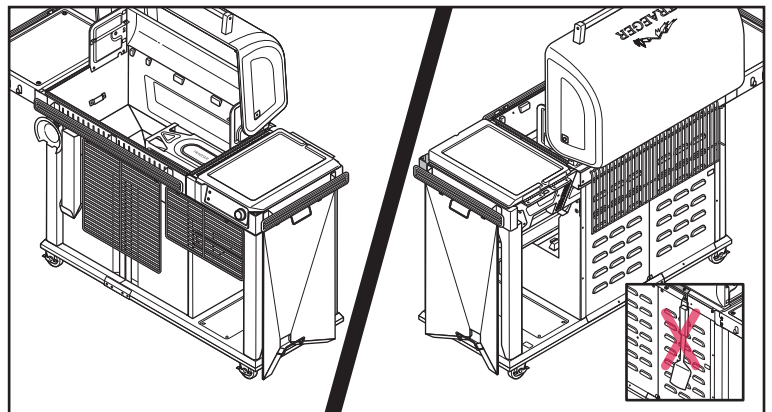
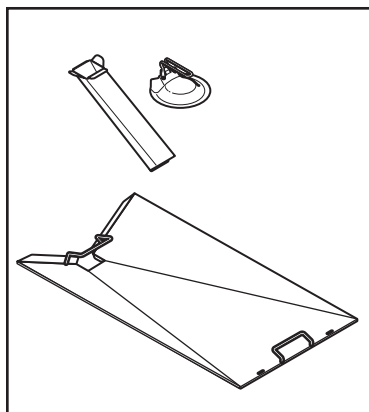
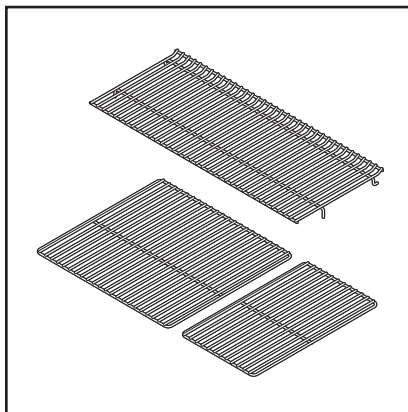

PRO TIP: Do not hang or store cooking utensils on grate hooks. Doing so could damage the utensils.

STORING PARTS AND ACCESSORIES (CONT.)

Hopper

If you will not be using your Traeger Woodridge Grill for an extended time, empty the pellets from the hopper.

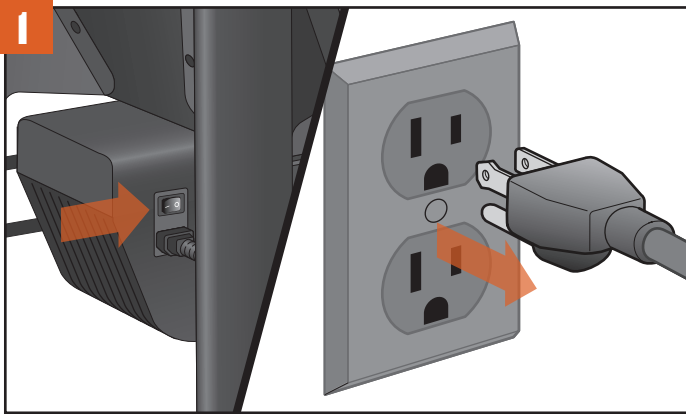

Press the main power switch to OFF (0) and disconnect the power cord. If the grill is still hot, allow it to cool completely.

NOTE: Plug appearance may vary by region.

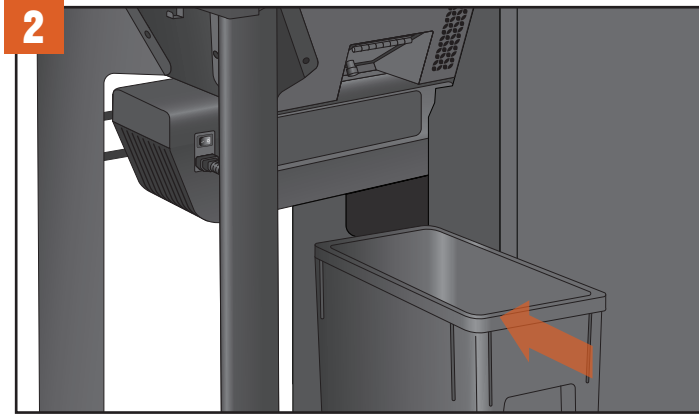

Before emptying the hopper, make sure that the Traeger StayDry Pellet Bin (sold separately) is placed directly underneath the pellet release door.

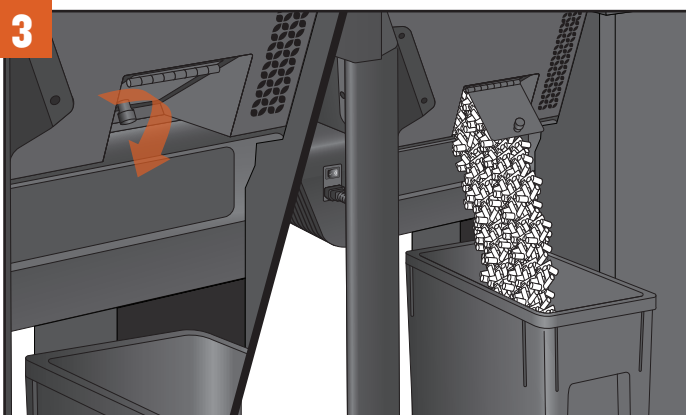

Unscrew the knob on the back of the auger box and open the pellet release door. Pellets will empty into the StayDry Pellet Bin. Vacuum out any remaining sawdust from the hopper and auger.



WARNING! DO NOT EMPTY OUT THE HOPPER UNTIL GRILL HAS COMPLETELY COOLED AND THE POWER IS OFF; OTHERWISE, PELLETS MAY BE VERY HOT.



WARNING! DO NOT PLACE YOUR HAND IN THE HOPPER PAST THE SAFETY GRATE.

CONNECTING YOUR GRILL

Our dedication to delivering world-class products and experiences means we are constantly working to improve grill performance and features. We highly recommend connecting your Traeger Woodridge Grill to WiFIRE by following the instructions below. When your grill is connected and on, updates will automatically download, ensuring your grill is always operating at peak performance.

IMPORTANT:

- Make sure your smart device is running on the latest operating system and that Bluetooth is turned ON.
- If using an Android device, turn on location services.
- To connect your grill to your home Wi-Fi, your grill must be powered on. Make sure the main power switch is pressed to ON and lit up.
- Your home Wi-Fi router signal must be 2.4 GHz (a dual band router should also work). The 2.4 GHz band is currently industry standard for connected appliances. It has better range and penetrates walls/ceilings/obstacles better than 5 GHz, which your grill cannot recognize.

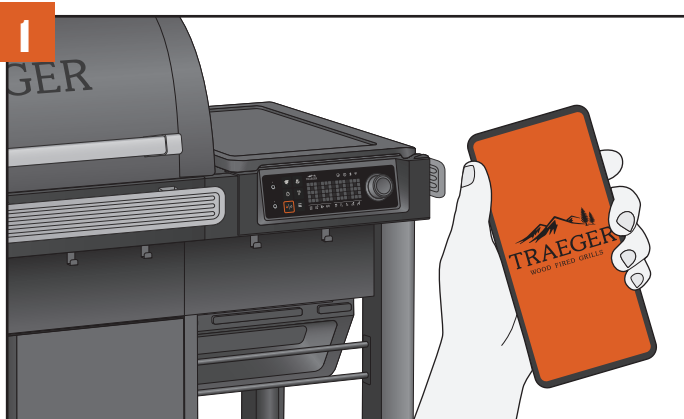
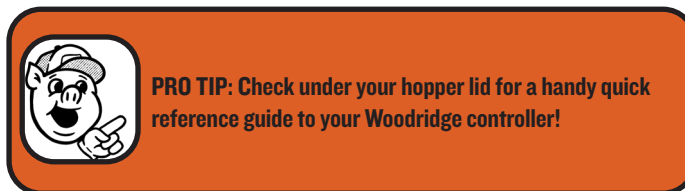
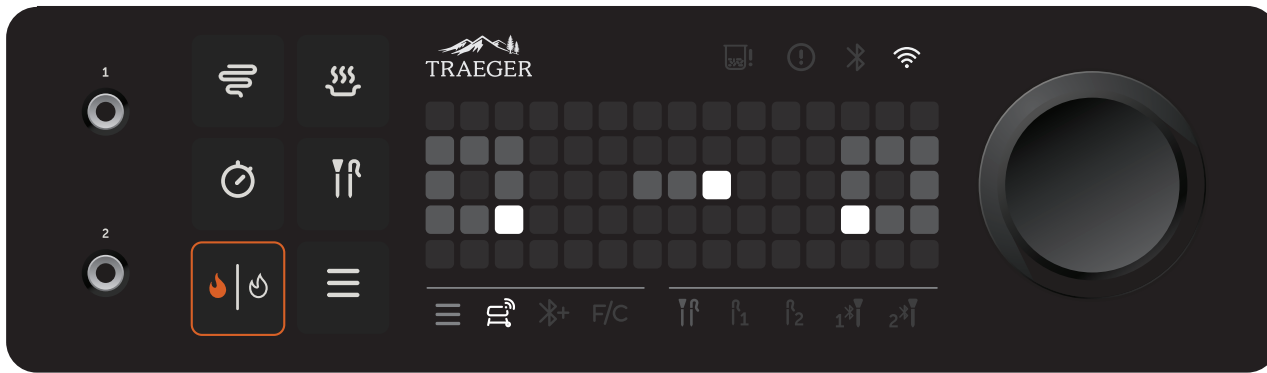

Go to the Apple App Store or Android Google Play Store to download the latest version of the Traeger App.

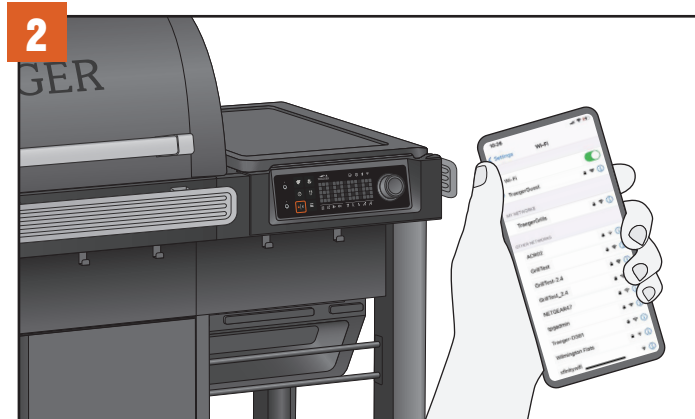

Ensure your smart device is connected to the Wi-Fi network to which you want your grill connected. The router signal must be 2.4 GHz, as the grill is not compatible with 5 GHz.

CONNECTING YOUR GRILL (CONT.)

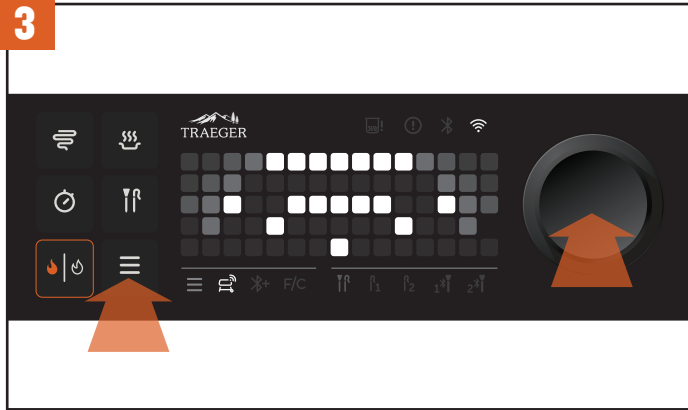

After powering on your grill, tap the menu button. You will see the Wi-Fi grill icon light up in the menu bar below the dot matrix, and an animation of a Wi-Fi signal with a question mark will be displayed. Press the selection dial to select this option and begin the connection process.

NOTE: You can navigate menu options by turning the selection dial after tapping the menu button. As you turn the dial, the menu bar icons below the dot matrix display will light up to indicate your selection.

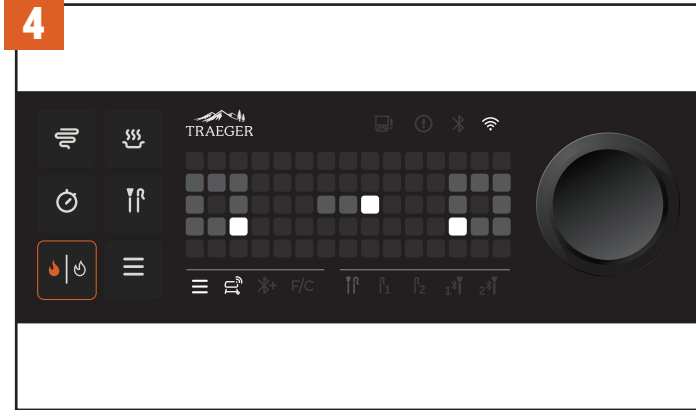

After selecting WiFIRE, the pairing animation above will display on screen, indicating that your grill is broadcasting its Bluetooth signal and is ready to pair. Open your smart device to the Traeger App and sign in to your account. On the home screen of the Traeger App, tap the grill icon in the lower centre of the screen to start connecting.

Follow the instructions on the Traeger App to (1) pair your phone to your grill (via temporary Bluetooth connection), (2) connect your grill to your desired 2.4 GHz home Wi-Fi network, and (3) complete the grill setup process.

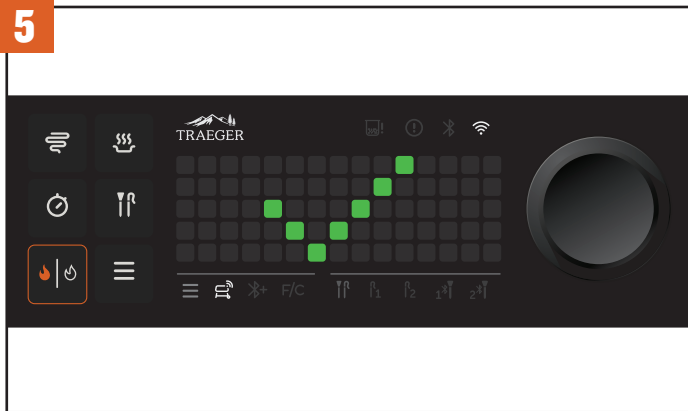

A green checkmark will display on your controller to indicate that you have successfully connected to WiFIRE. The Wi-Fi icon in the top right above the dot matrix display will stay lit up when the grill is connected.

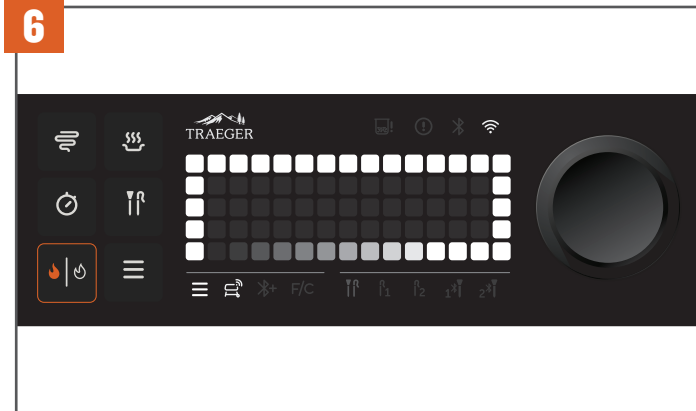

Once connected to WiFIRE, you might see this animation on your screen. Don't turn off your grill until you see a green checkmark. This means that your grill is downloading and applying an update. Just like your smartphone, these updates keep your grill running smoothly, securely, and at peak performance. Once the update is done, you'll see a green checkmark and the grill will return to the idle mode – let's cook!

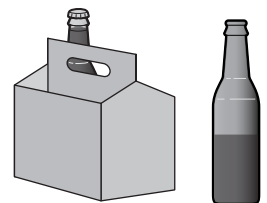

SEASONING YOUR GRILL

 **PRO TIP:** Seasoning must be completed before cooking food on your grill. For more information, scan here to access the Seasoning Guide.



Before you can cook on your grill, the grill must be seasoned. This is a hands-off process in which the empty grill gets heated to a very high temperature. This seasoning cycle ensures the grill is cleaned of any factory residue, primed, and ready for optimal performance.

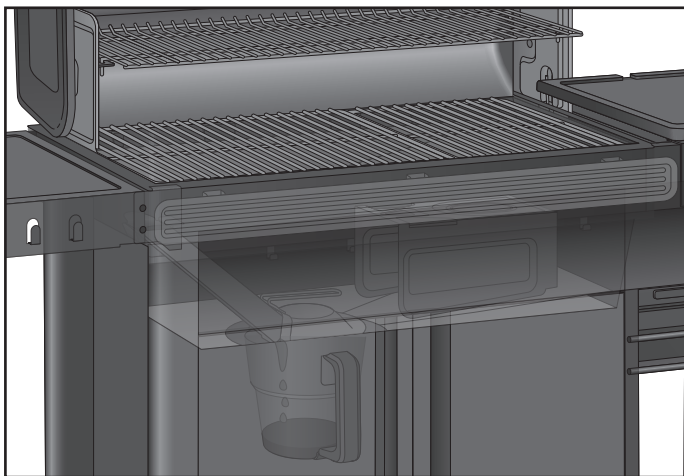

IMPORTANT:

- Make sure all components are properly installed in the grill and that all packaging/shipping materials are removed prior to seasoning.
- Do not wipe protective grease coating off of components before seasoning. This coating provides a more durable burn-in protective layer.

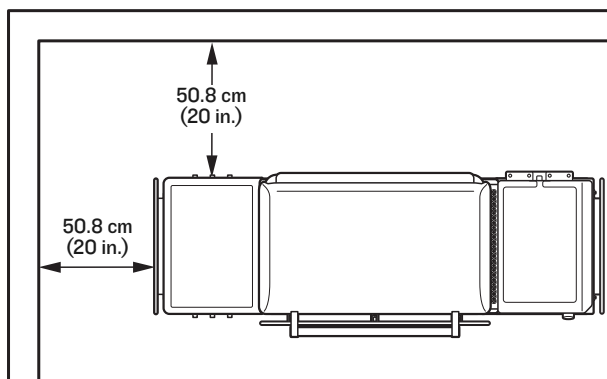

⚠ WARNING Fire Hazard

- When operating your Traeger Grill, maintain a **MINIMUM** distance of 50.8 cm (20 inches) from the grill to any nearby combustibles, including wooden railings, home siding, window frames, furniture, trees, trash receptacles, etc.

⚠ DANGER Carbon Monoxide Hazard

Burning wood pellets produces carbon monoxide which may lead to illness, serious injury, and/or death. Follow these guidelines to prevent this colorless, odorless gas from poisoning you, your family, your pets, or others:

- Only use your Traeger Grill outside in a well-ventilated area. This grill is intended for **OUTDOOR USE ONLY**.
- **Never** use your Traeger Grill in any enclosed area or any area without adequate ventilation.
- Know the symptoms of carbon monoxide poisoning: headache, dizziness, weakness, nausea, vomiting, sleepiness, and confusion. Carbon monoxide reduces the blood's ability to carry oxygen. Low blood oxygen levels can result in loss of consciousness and death.
- See a doctor if you or others develop cold- or flu-like symptoms while cooking or in the vicinity of this appliance. Carbon monoxide poisoning, which can easily be mistaken for a cold or flu, is often detected too late.
- Alcohol consumption and drug use increase the effects of carbon monoxide poisoning.
- Carbon monoxide is especially toxic to mother and child during pregnancy, infants, the elderly, smokers, and people with blood or circulatory system problems, such as anemia or heart disease.

⚠ WARNING Fire Hazard

- **Never** use gasoline, lantern fuel, kerosene, lighter fluid, or other flammable materials to start or "freshen up" a fire.
- **Never** use or store flammable liquids or other combustible materials near the grill.

⚠ WARNING Burn Hazard

Ashes should always be completely cool before handling. Ashes should be placed in a metal container with a tight-fitting lid. The closed container of ashes should be placed on a noncombustible floor or on the ground, well away from all combustible materials, pending final disposal. Ashes should be retained in the closed container until they are disposed.

⚠ WARNING Do Not Use Fuel Pellets

Never use heating fuel pellets in the grill because they may contain hazardous contaminants and additives and may damage the grill.

SEASONING YOUR GRILL (CONT.)

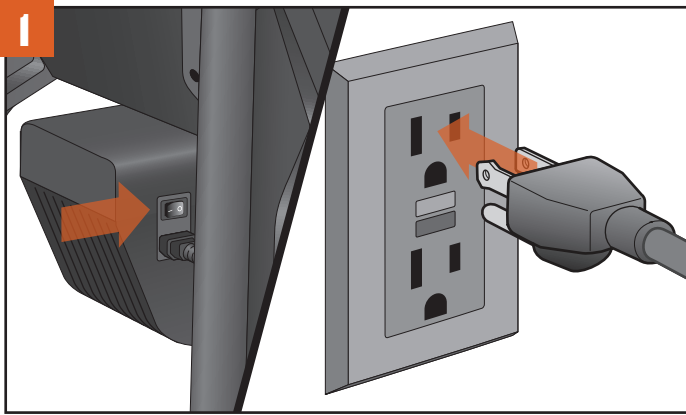

With the main power switch set to OFF (0), connect the power cord to your grill. Then plug the power cord into a properly grounded/earthed electrical outlet protected by a Ground Fault Circuit Interrupter (GFCI).

NOTE: Plug appearance may vary by region.

 **WARNING! ELECTRICAL SHOCK HAZARD**
HAZARDOUS VOLTAGE IS PRESENT, WHICH CAN SHOCK, BURN, OR CAUSE DEATH.

- GROUND FAULT CIRCUIT INTERRUPTER (GFCI) PROTECTION MUST BE PROVIDED ON THE CIRCUIT(S) OR OUTLET(S) TO BE USED FOR THE OPERATION OF THIS TRAEGER GRILL.



To add pellets, open the hopper lid and inspect for any foreign objects in the auger. Fill the hopper with pellets at least to the safety grate and close the lid.

USE ONLY TRAEGER HARDWOOD PELLETS. This product is developed and tuned using only Traeger pellets. Traeger pellets are crafted to meet strict quality and performance standards. Using pellets not manufactured by Traeger may result in inconsistent performance, poor flavour, and temperature inconsistency.



Press the main power switch, located on the back of the auger box, to ON (I). Press the selection dial to wake up the controller. "TRAEGER" will scroll across the screen, indicating the grill is on.



Turn the selection dial to set the grill's temperature to 350°F (177°C), then press the dial. Press the ignite/shutdown button.



PRO TIP: This seasoning process is important to ensure proper grill performance. Make sure that all internal components have been properly installed prior to this seasoning cycle and that there is no food on the grill grates during this cycle.



The grill temperature will display as it increases to the set temperature.

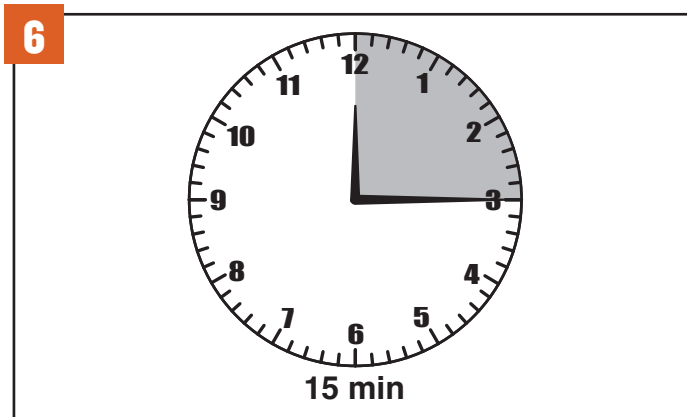

Once the grill has reached 350°F (177°C), let it run for 15 minutes. While the grill is seasoning, you may see dark or excessive smoke and ash; this is normal and will be less on future startups.



After 15 minutes at 350°F (177°C), increase the temperature to 500°F (260°C).

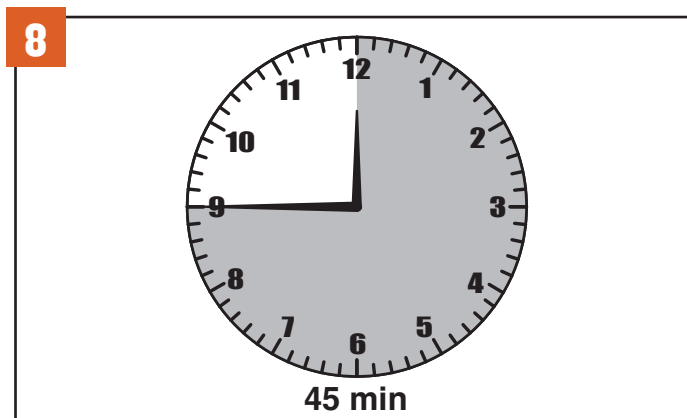

Once the grill has reached 500°F (260°C), let it run for another 45 minutes to ensure seasoning is completed properly.

NOTE: Getting to first-time seasoning temperature may take up to an hour.



SEASONING YOUR GRILL (CONT.)

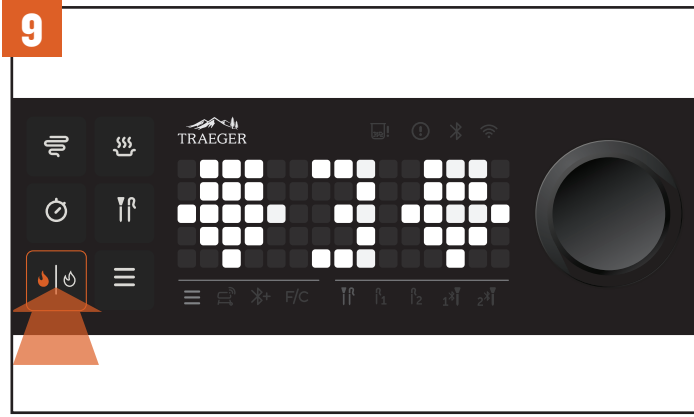

After 45 minutes at 500°F (260°C), shut down the grill and let the shutdown cycle complete. To shut down your grill, press and hold the ignite/shutdown button or the selection dial for three seconds until the display shows the shutdown animation.

NOTE: Always initiate a shutdown cycle after each and every cook.

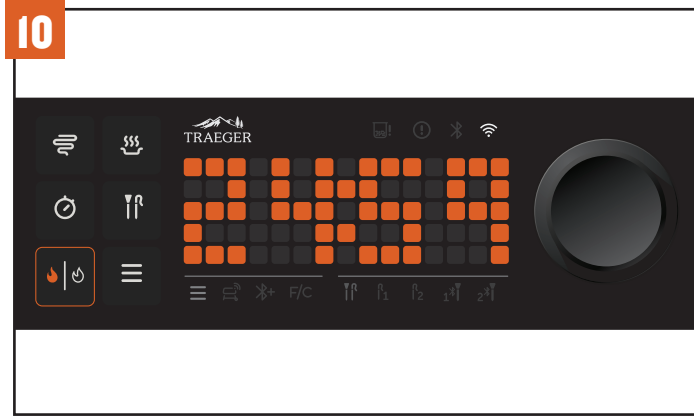

A countdown timer begins while the grill is shutting down. You will hear the fan continue to run.

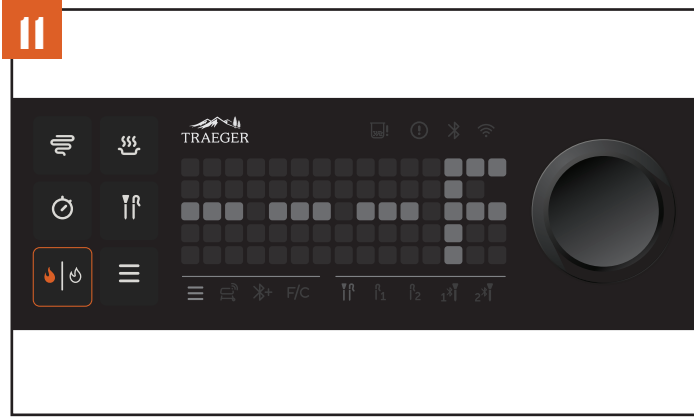

Once this countdown is complete, the shutdown cycle is complete.

NOTE: It is normal to observe ash on the drip tray and/or grill grates after seasoning. Simply wipe away ash on grill grates prior to your first cook.

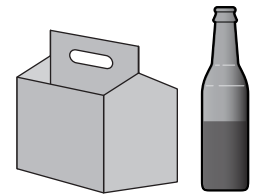

HOW TO COOK ON YOUR TRAEGER

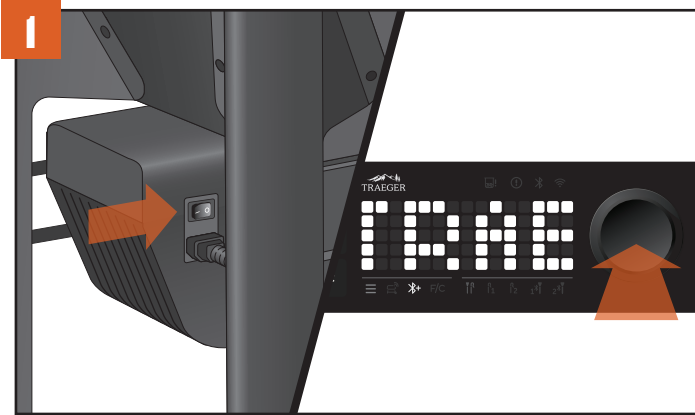

With the lid closed, press the main power switch located on the back of the auger box to **ON (I)**. Press the selection dial or tap the ignite/shutdown button to wake the grill. A splash screen will appear after a few seconds as the grill powers on.

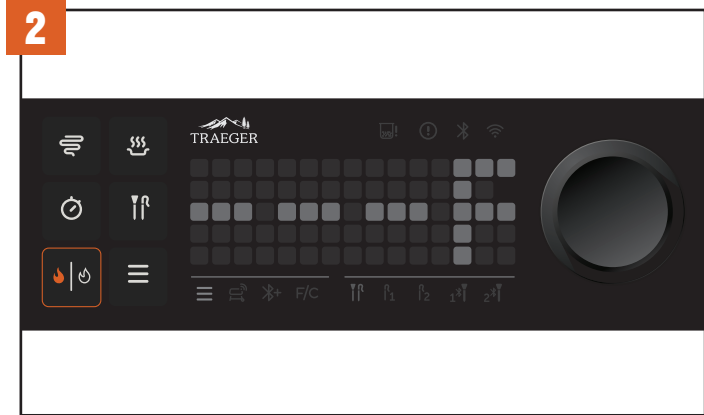

The dot matrix displays three dashes and F or C. This is the home screen when your grill is idle. You can set a grill temperature directly from this screen.

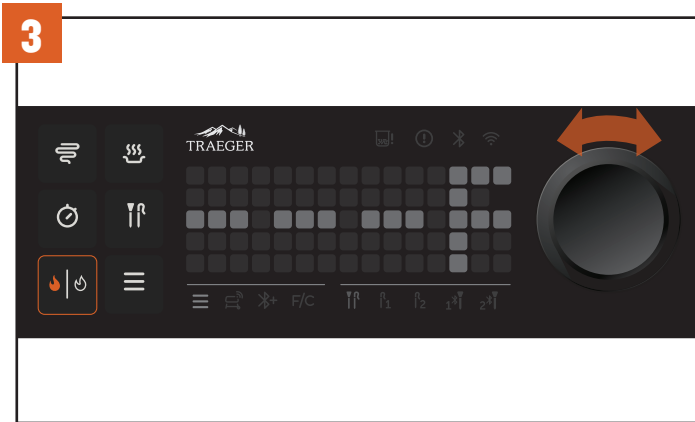

To select a temperature, rotate the selection dial to the right to increase the temperature, or to the left to lower the temperature.

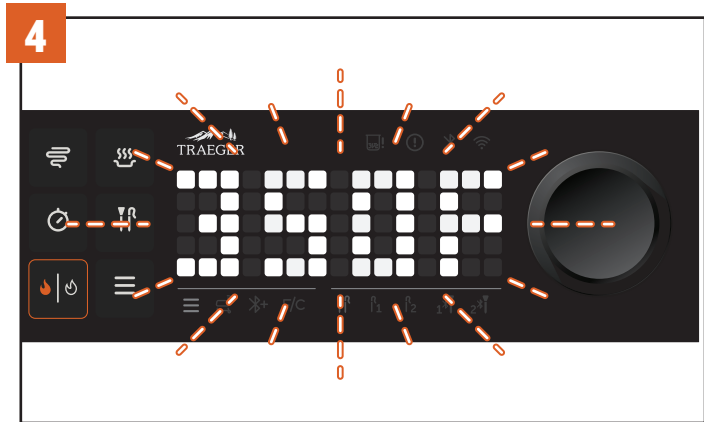

The selected temperature will blink on and off.

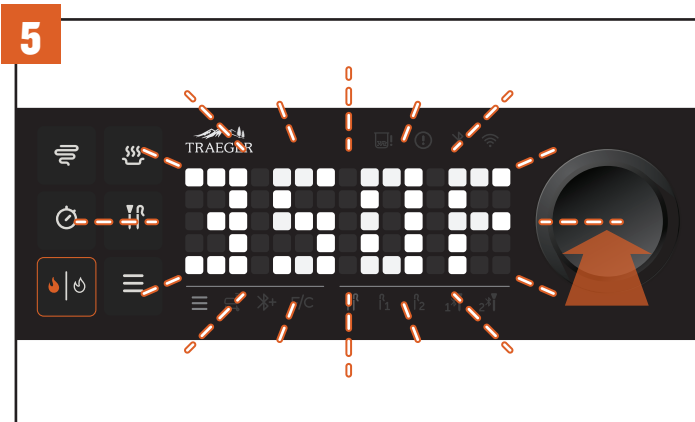

While the temperature is blinking, press the centre of the selection dial to select your desired temperature.

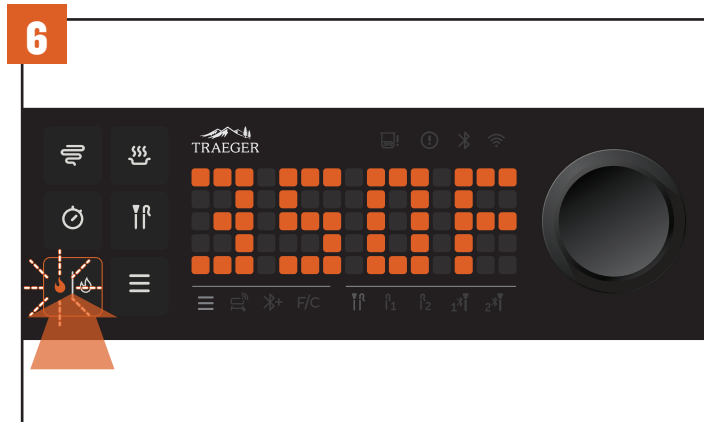

Once your temperature is selected, the temperature will change from white to orange, indicating that your set temperature is locked in. The ignite/shutdown button will now blink. Tap this button to start ignition. The grill will now ignite and preheat automatically to reach the temperature you set.

HOW TO COOK ON YOUR TRAEGER (CONT.)

7



While the grill is preheating, the controller will display an animated flame next to the temperature, indicating preheating mode. The current temperature will climb in 5-degree increments as the grill heats up.

8



Once the grill has reached the set temperature, the controller will no longer display the preheating arrow animation, and the current temperature will continue to hover within +/- 25°F (+/- 4°C) of the set temperature. These small temperature swings are completely normal for daily wood pellet grill use and are the natural result of fanning and monitoring the flame. Do not open the lid or adjust the set temperature before it is reached.

9

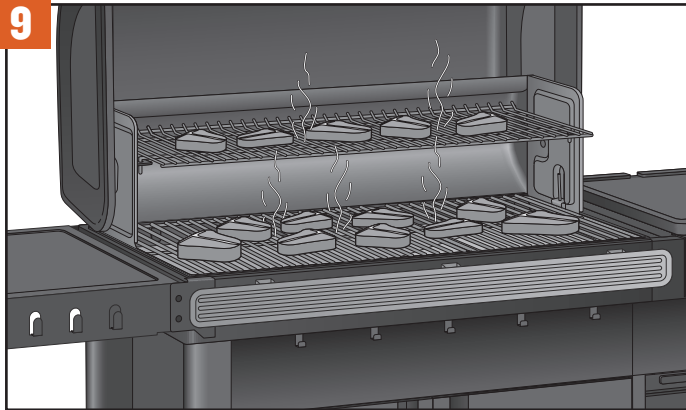

You are now ready to load up your grill with food and get cooking.

TIPS:

- Keep the grill closed during the preheat cycle so that the grill can reach the desired set temperature.
- Wait until the preheat cycle is complete before you begin cooking your food. Opening the lid before the desired temperature is reached can prevent you from getting the best cooking results.
- Adding food too early can result in the grill taking longer than usual to achieve your desired set temperature.
- **Traeger Woodridge Grills provide real-time temperature readings in five-degree increments, and you should expect to see fluctuations in temperature.**



PRO TIP: Cooking to a desired internal food temperature is the best-kept secret for getting great results.



NOTES







GUIDE DE MONTAGE

BARBECUE À GRANULES À BOIS WOODRIDGE ELITE



**SCANNEZ
POUR OBTENIR
DES INSTRUCTIONS
ANIMÉES
ÉTAPE PAR ÉTAPE**

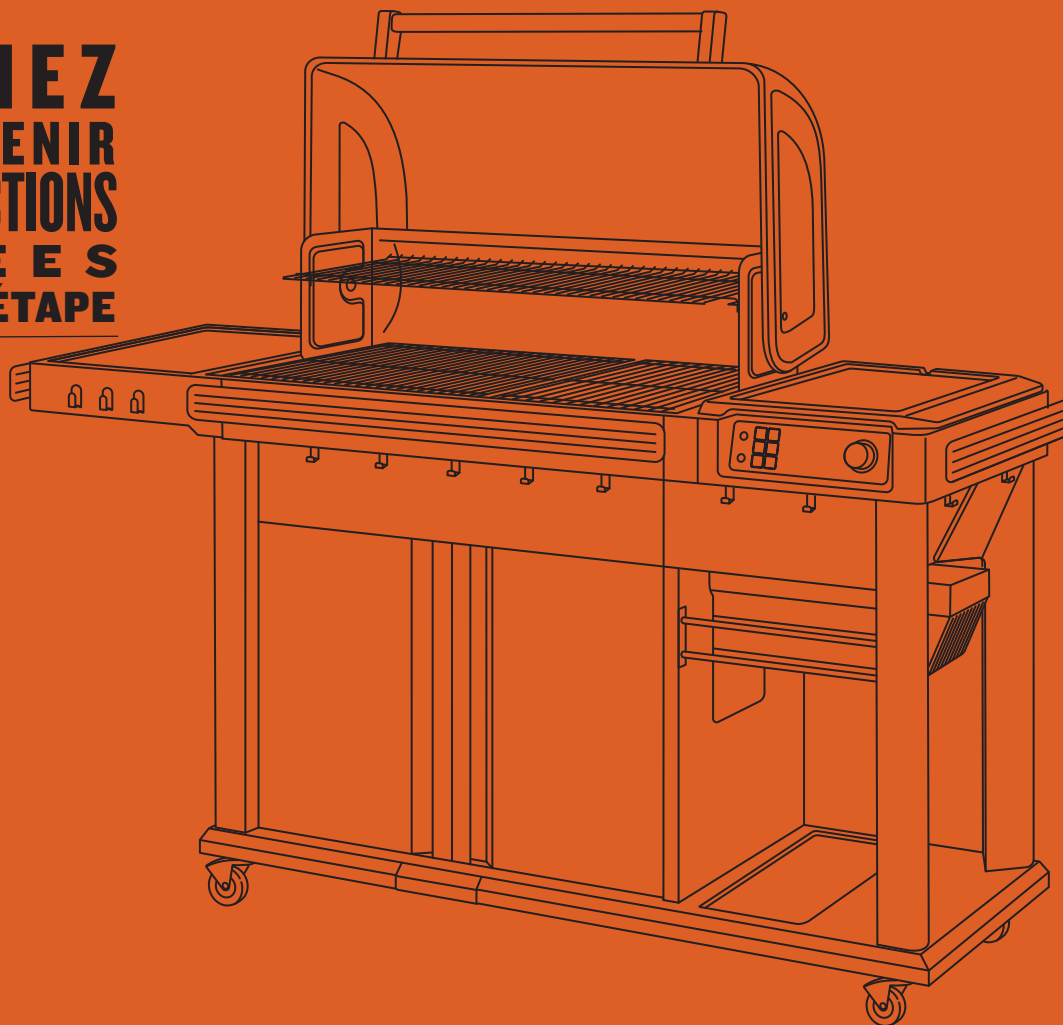

L'UNE DES PRINCIPALES CAUSES D'INCENDIE EST LE NON-RESPECT DES ESPACES REQUIS (ESPACES D'AIR) AVEC LES MATÉRIAUX COMBUSTIBLES. IL EST EXTRÊMEMENT IMPORTANT QUE CE PRODUIT SOIT INSTALLÉ CONFORMÉMENT À CES INSTRUCTIONS.

IMPORTANT : À CONSERVER POUR DE FUTURS BESOINS DE RÉFÉRENCE. LIRE ATTENTIVEMENT.

T18985

©2025 TRAERER PELLETT GRILLS LLC.
TOUS DROITS RÉSERVÉS.

TRAERER PELLETT GRILLS LLC

533 SOUTH 400 WEST
SALT LAKE CITY, UT 84101

[TRAERER.COM](https://www.traeger.com)



AVANT DE COMMENCER LE MONTAGE

VEUILLEZ LIRE CE GUIDE DE MONTAGE ET VOTRE MANUEL D'UTILISATION AVANT L'INSTALLATION ET L'UTILISATION DE VOTRE BARBECUE TRAEGER. LE NON-RESPECT DES INSTRUCTIONS DE CE GUIDE DE MONTAGE ET DE VOTRE MANUEL DU PROPRIÉTAIRE PEUT ENTRAÎNER DES DOMMAGES MATÉRIELS, DES BLESSURES CORPORELLES, VOIRE LA MORT.

Lorsque vous utilisez votre barbecue, maintenez une distance MINIMALE de 50,8 cm (20 po) entre le barbecue et tout matériau combustible à proximité, notamment les rampes en bois, le revêtement extérieur de la maison, les cadres de fenêtres, les meubles, les arbres, les poubelles, etc. N'installez pas et n'utilisez pas ce barbecue sur des sols ou des surfaces combustibles, à l'intérieur, ni sous un plafond ou un surplomb combustible. Lisez le manuel d'utilisation pour obtenir des instructions et des avertissements supplémentaires.

ESPACE D'INSTALLATION



CONSEIL DE PRO : construisez sur le plateau inférieur de la boîte d'expédition pour éviter les rayures.

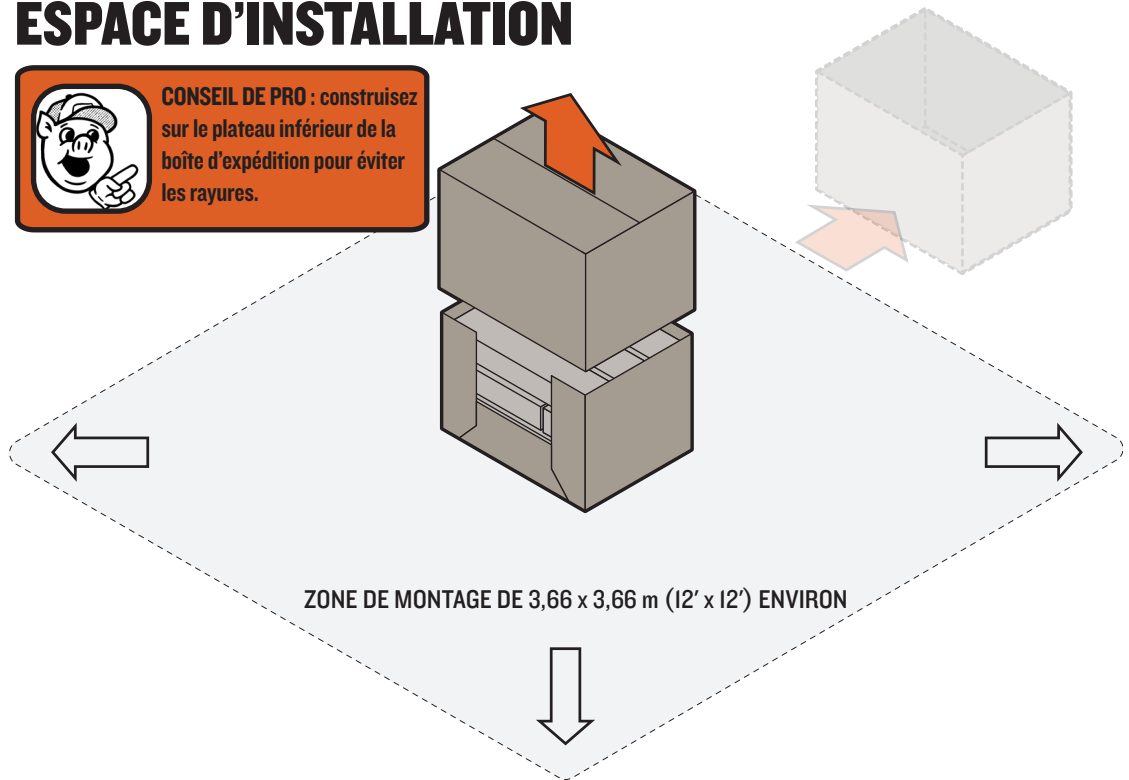

CONSEIL DE PRO : nous vous recommandons de monter votre barbecue avec deux personnes.

INSTALLATION

Une fois tous les composants déballés, disposez les pièces sur le plateau inférieur de la boîte d'expédition.

REGROUPEZ LES BOÎTES EN FONCTION DE LEURS SYMBOLES D'IDENTIFICATION, COMME INDIQUÉ CI-DESSOUS :



COMPARTIMENTS ET PIEDS



ARMOIRE ET ROULETTES



ÉTAGÈRE LATÉRALE PLIANTE, BASE ET PANNEAU DE COMMANDE



COUVERCLE ET COMPOSANTS INTERNES DU BARBECUE

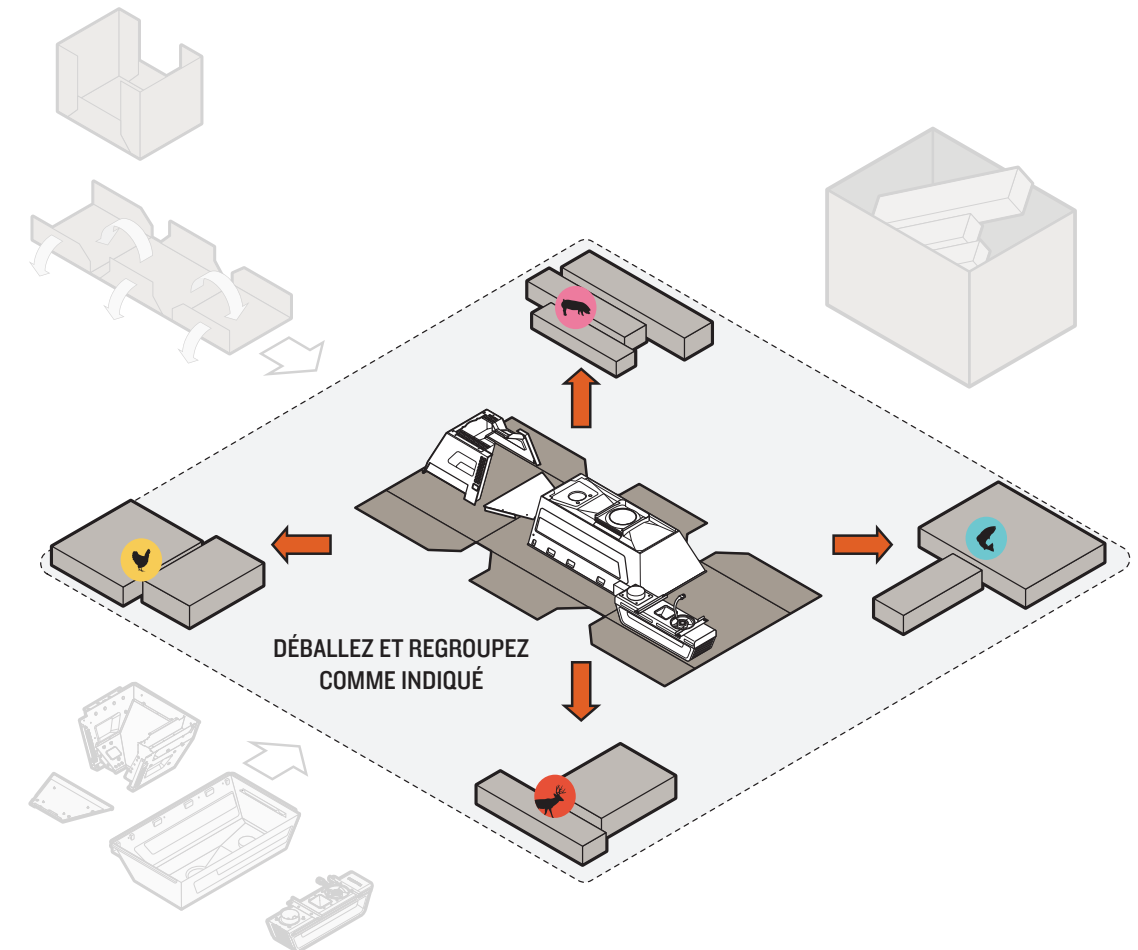



MATÉRIEL (QUANTITÉS TOTALES)

ÉCHELLE 1:1

A

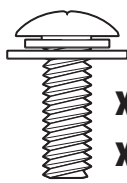

x42
x2 extra

1/4
20
0,75 po

B

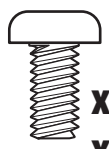

x101
x6 extra

1/4
20
0,5 po

C

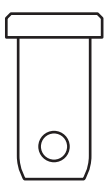

x2

0,375
GOUPILLE À
ÉPAULEMENT

D

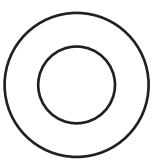

x2

0,375
RONDELLE

E

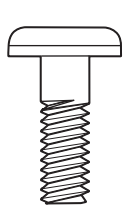

x4

1/4
20
0,38 po

F



x4

PLAQUE DE
MONTAGE

G

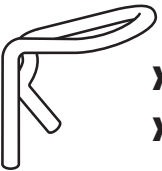

x2
x1 extra

120°
GOUPILLE
FENDUE

H



x2 extra

PARE-CHOCS
EN SILICONE

I



x2

GOUPILLE INFÉRIEURE,
PORTE D'ARMOIRE





CHAPITRES

CHAPITRE 1 – PAGE 5

COMPARTIMENTS ET PIEDS

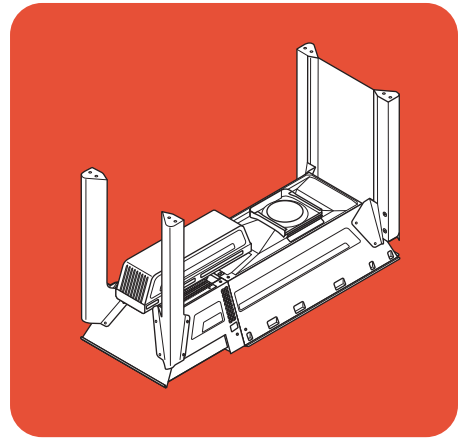

CHAPITRE 2 – PAGE 13

ARMOIRE ET ROULETTES

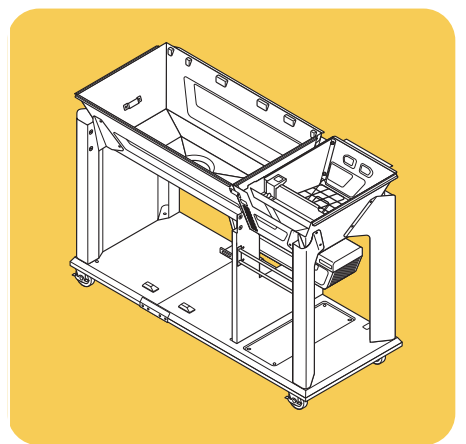

CHAPITRE 3 – PAGE 21

ÉTAGÈRE LATÉRALE PLIANTE, BASE ET PANNEAU DE COMMANDE

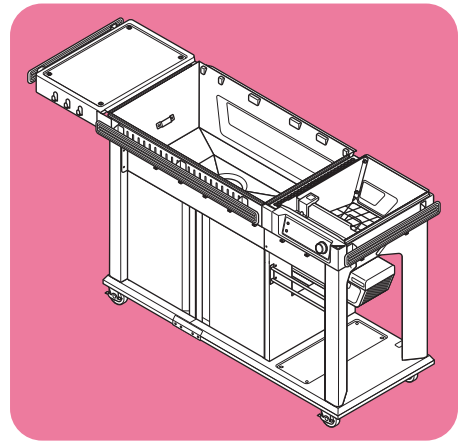

CHAPITRE 4 – PAGE 40

COUVERCLE ET COMPOSANTS INTERNES DU BARBECUE

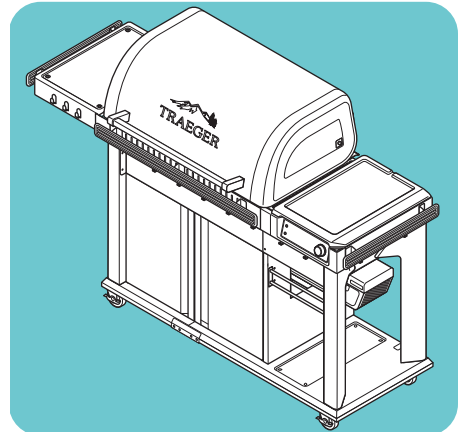

CHAPITRE 1

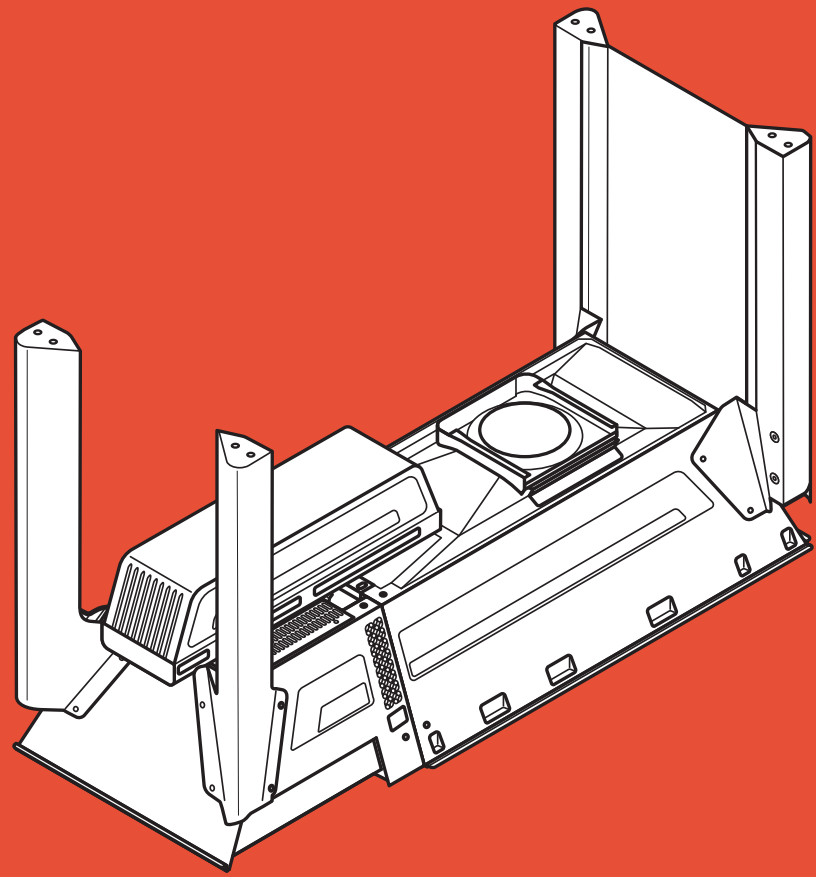

COMPARTIMENTS ET PIEDS

CHAPITRE 1

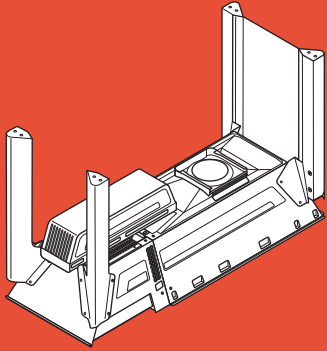

1 INSTALLER LA GRILLE DE SÉCURITÉ

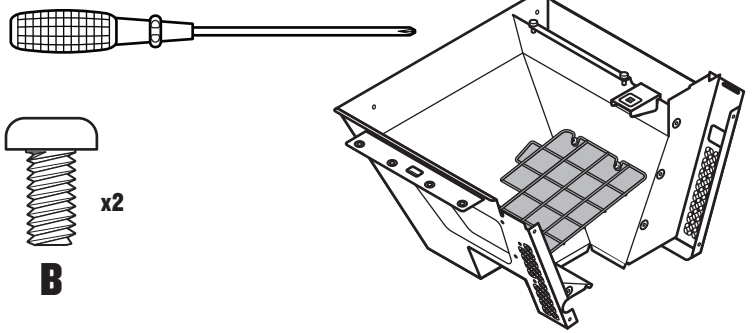

CONSEIL DE PRO : serrez d'abord toutes les vis à la main, puis terminez le serrage avec un tournevis.

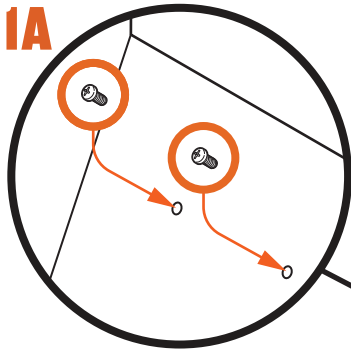

IB

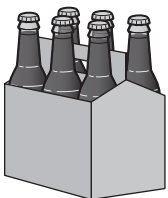
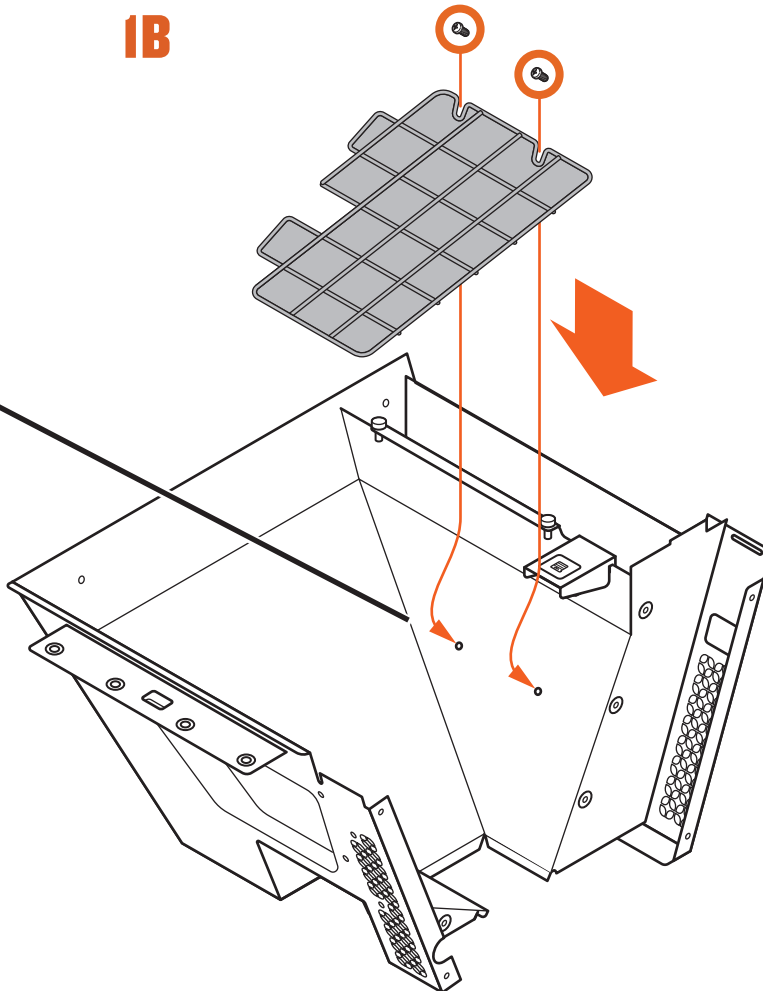

6



2 MONTER LA TRÉMIE

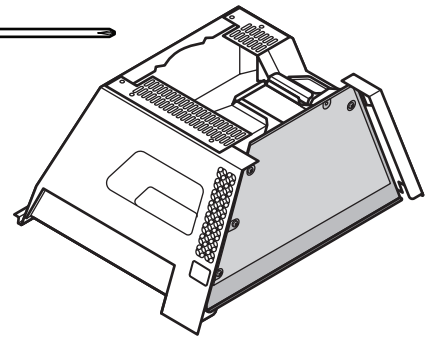
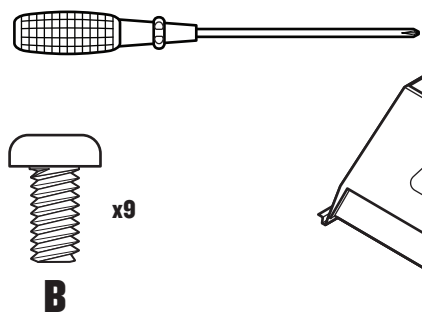

2A

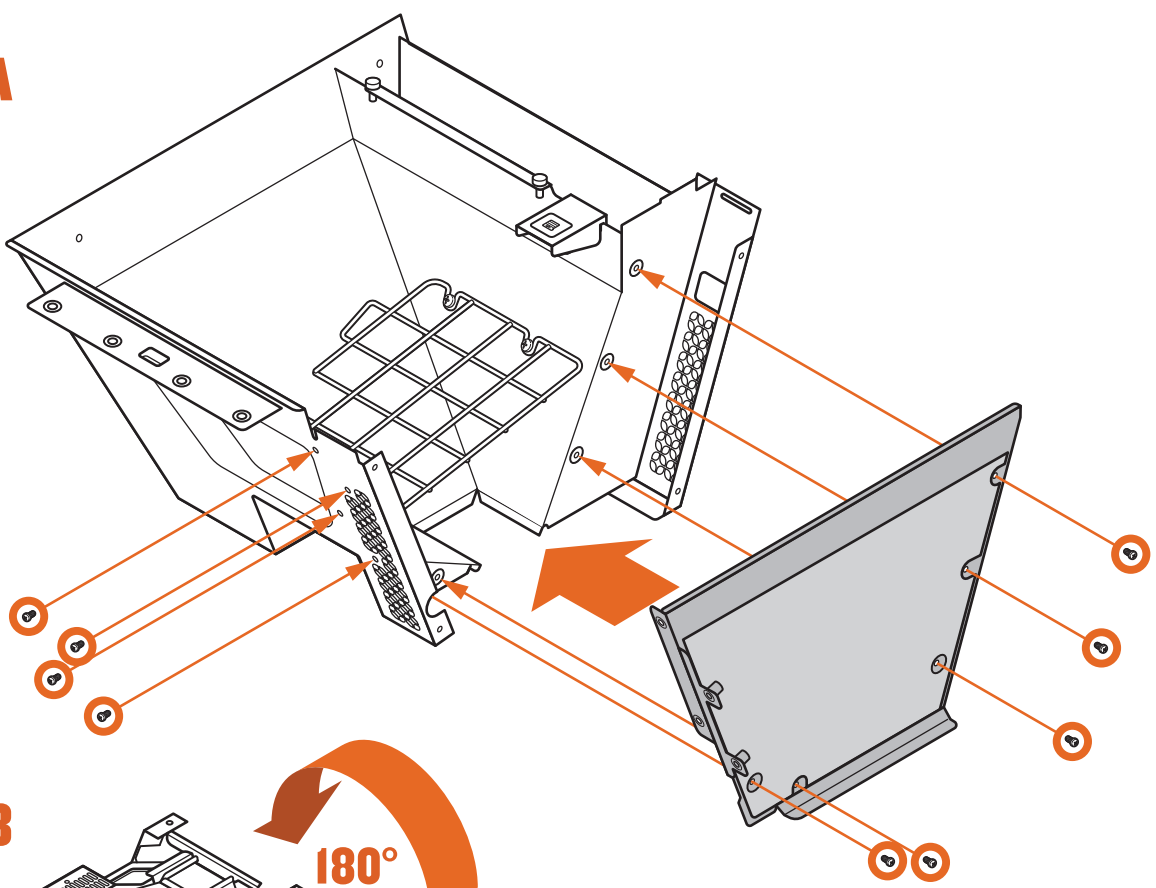

2B

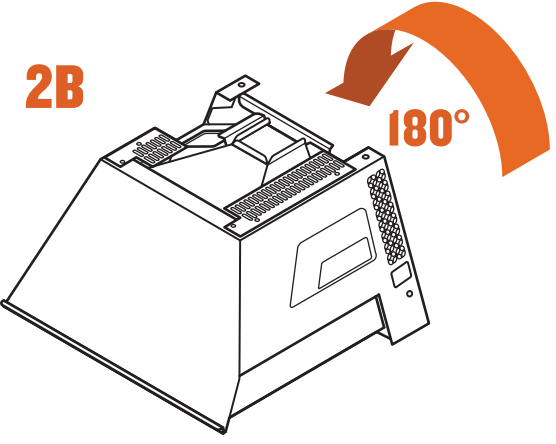



3A FIXER LA TRÉMIE AU CORPS

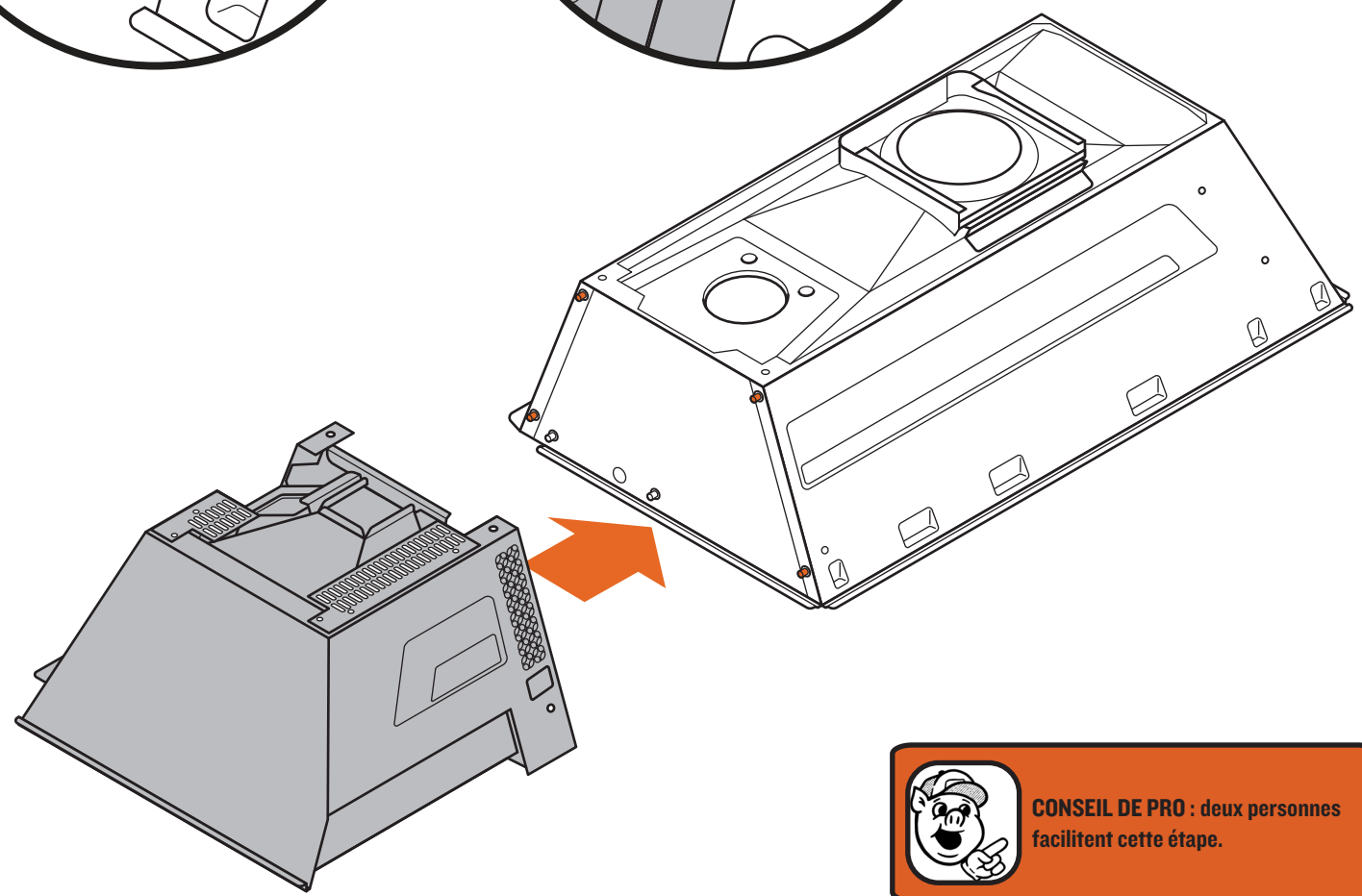
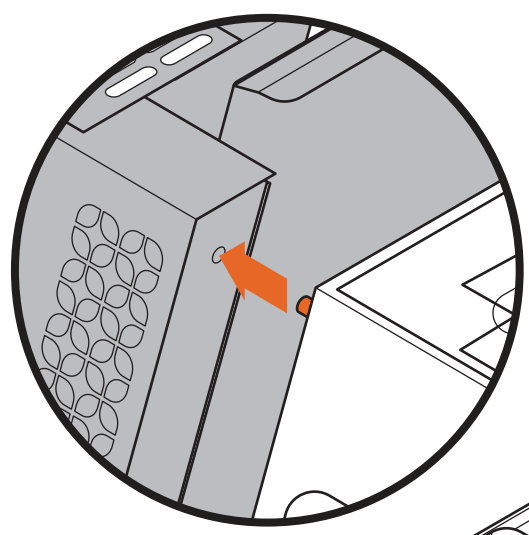
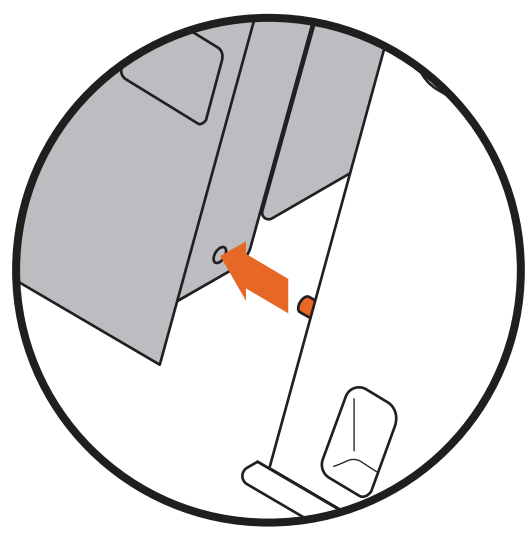
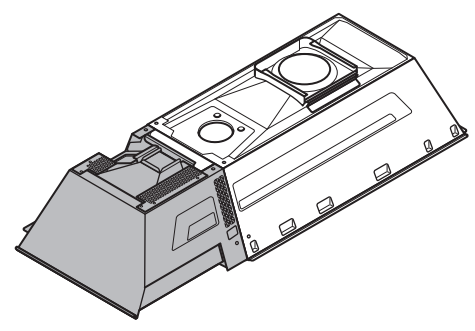

 **CONSEIL DE PRO : deux personnes facilitent cette étape.**





3B FIXER LA TRÉMIE AU CORPS

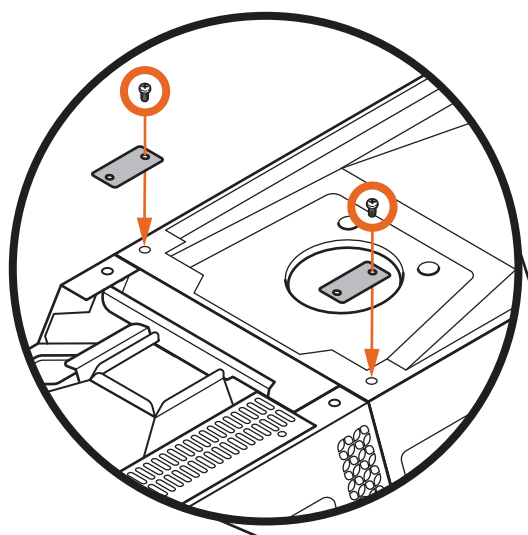
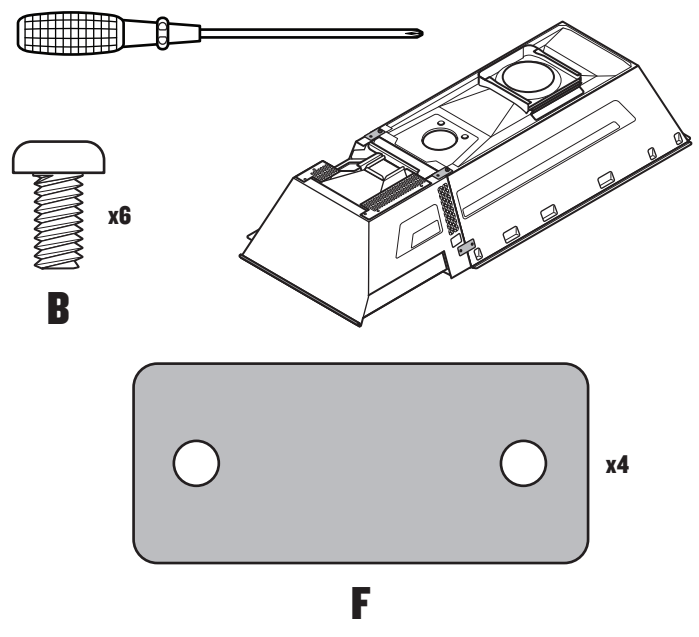

 **CONSEIL DE PRO :** installez une seule vis dans chaque support supérieur.

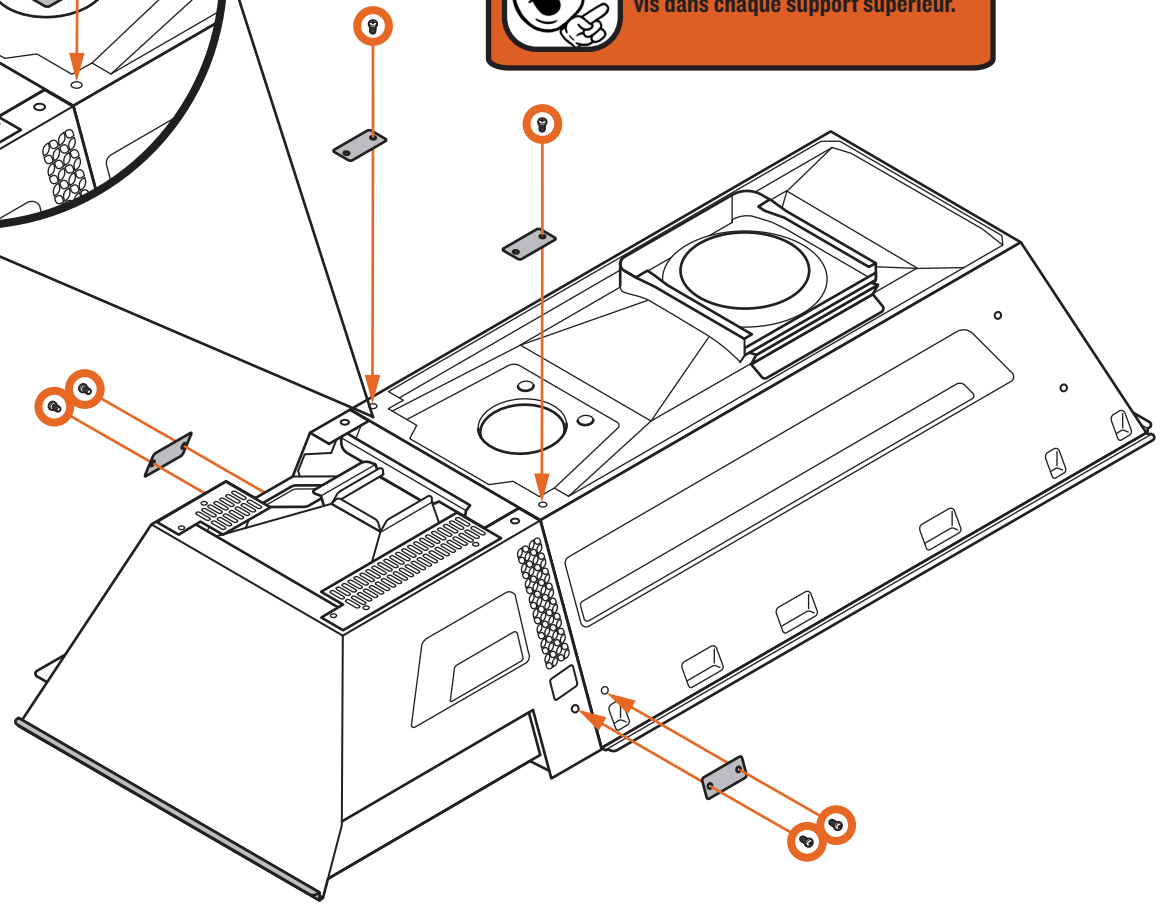



CONNECTEUR
À 12 BROCHES

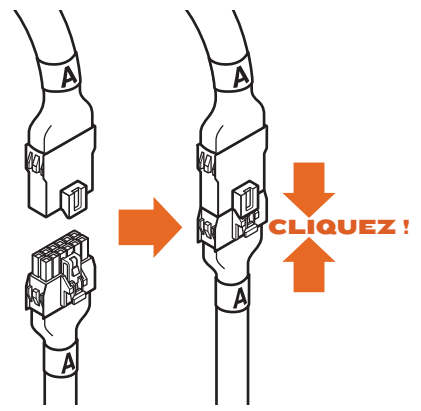
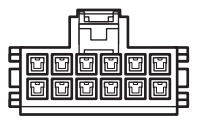

4 CONNECTER LE BOÎTIER DE LA VIS SANS FIN

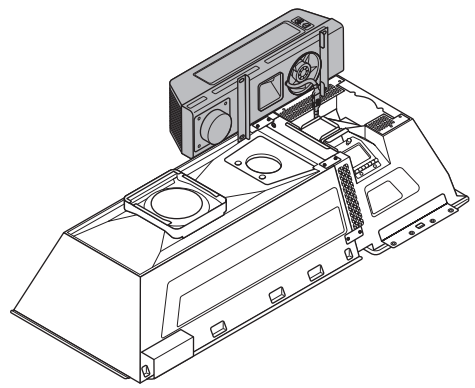

CONSEIL DE PRO : demandez à une deuxième personne de tenir le boîtier de la vis sans fin pendant que vous branchez le cordon.



CONSEIL DE PRO : n'oubliez pas de retirer le lien torsadé et le ruban adhésif qui maintiennent le cordon.

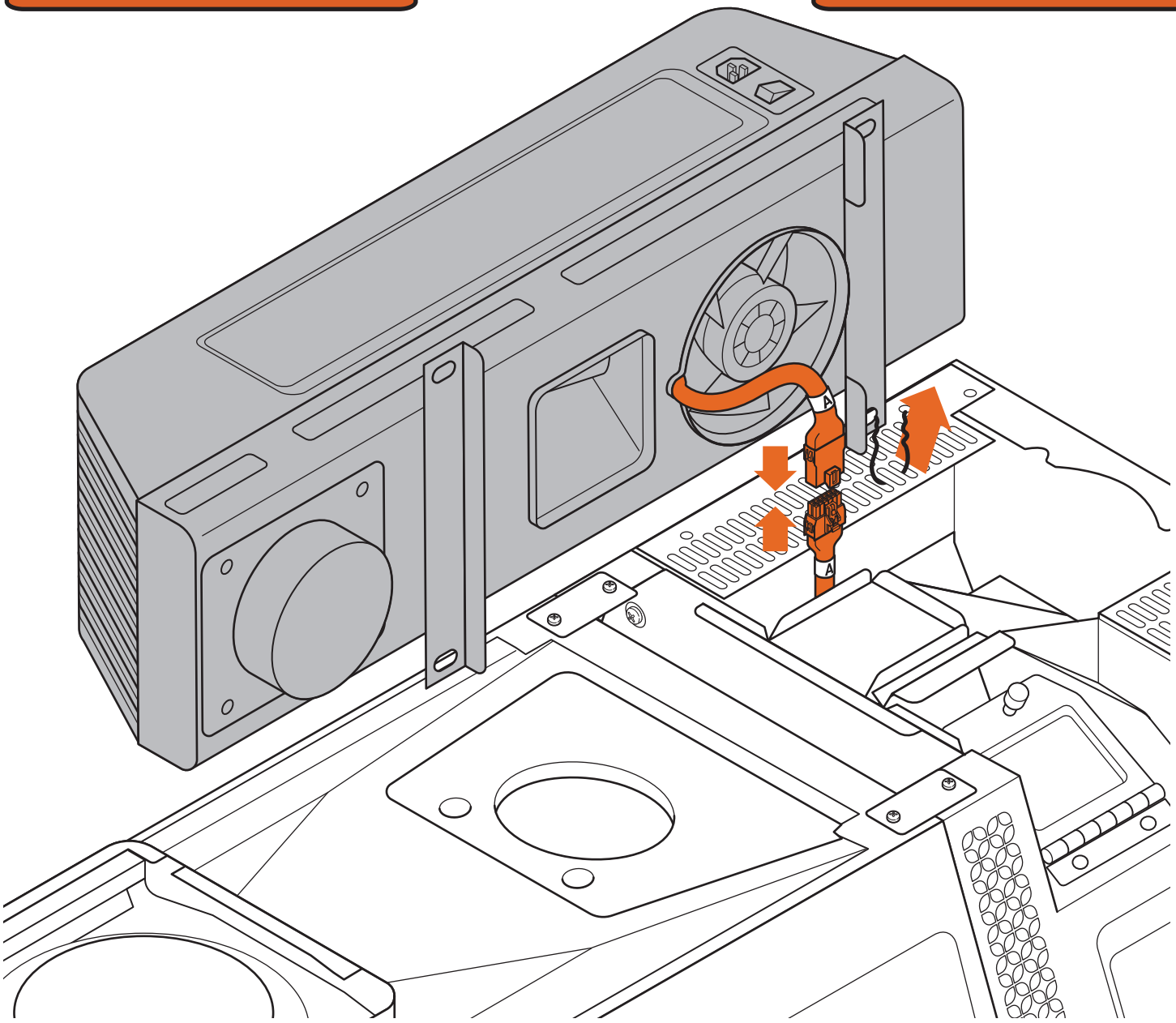



5 FIXER LE BOÎTIER DE LA VIS SANS FIN DE LA VIS SANS FIN

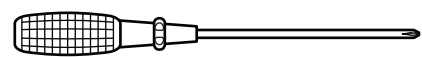

Utilisez CETTE vis maintenant !

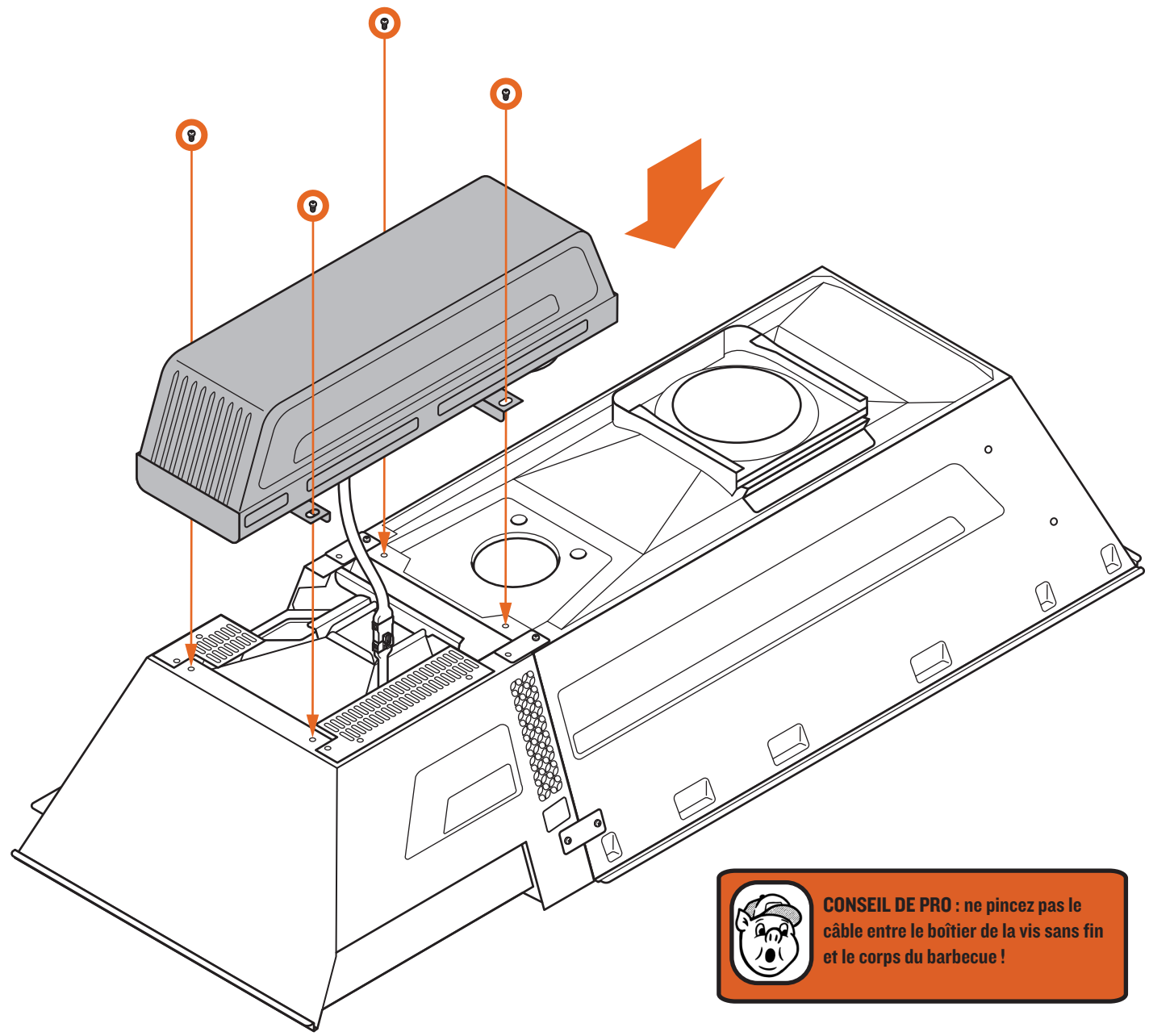
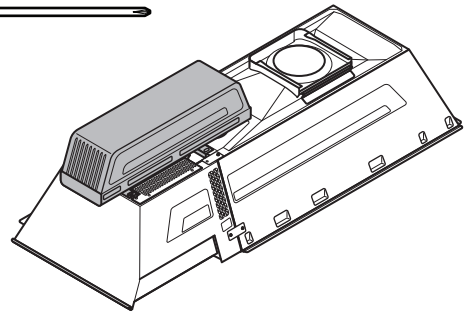
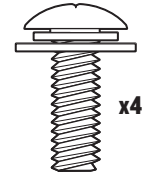

 **CONSEIL DE PRO :** ne pincez pas le câble entre le boîtier de la vis sans fin et le corps du barbecue !





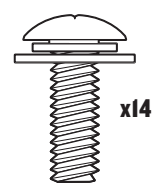
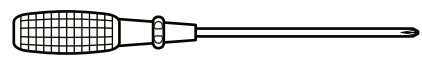

6 FIXER LES PIEDS

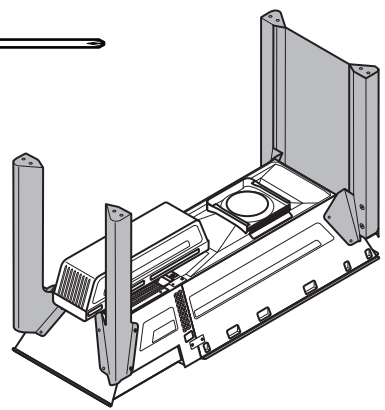

A



 **CONSEIL DE PRO :** alignez les trous de vis dans les pieds avec les trous de vis dans le corps du barbecue et la trémie.

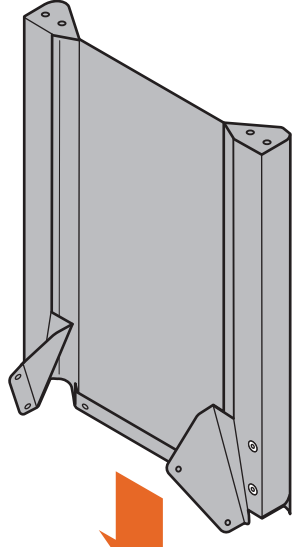

 **CONSEIL DE PRO :** vous pouvez presser doucement les pieds pour aligner les vis avant de terminer le serrage avec un tournevis.

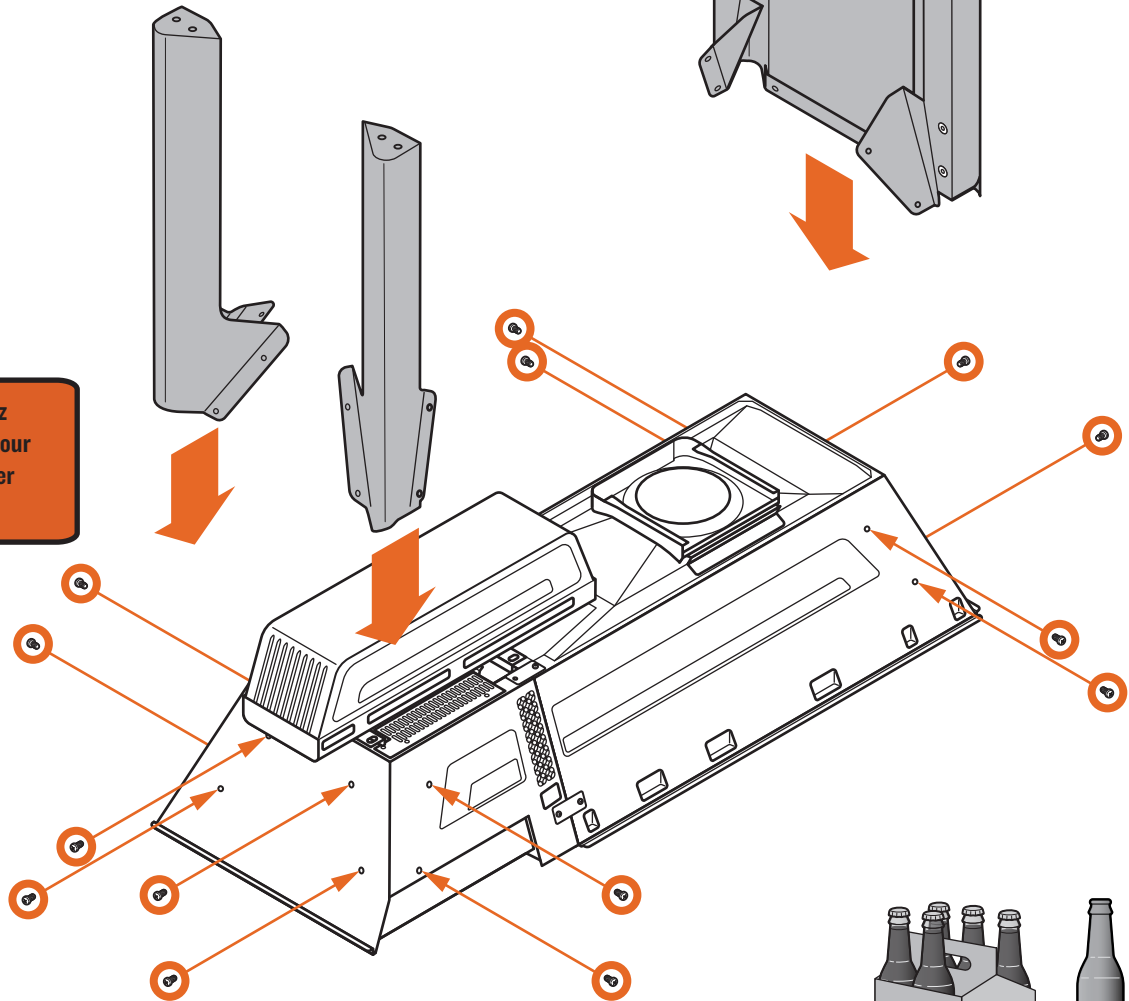

**BEAU TRAVAIL !
CHAPITRE I TERMINÉ !**

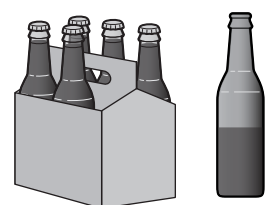

CHAPITRE 2

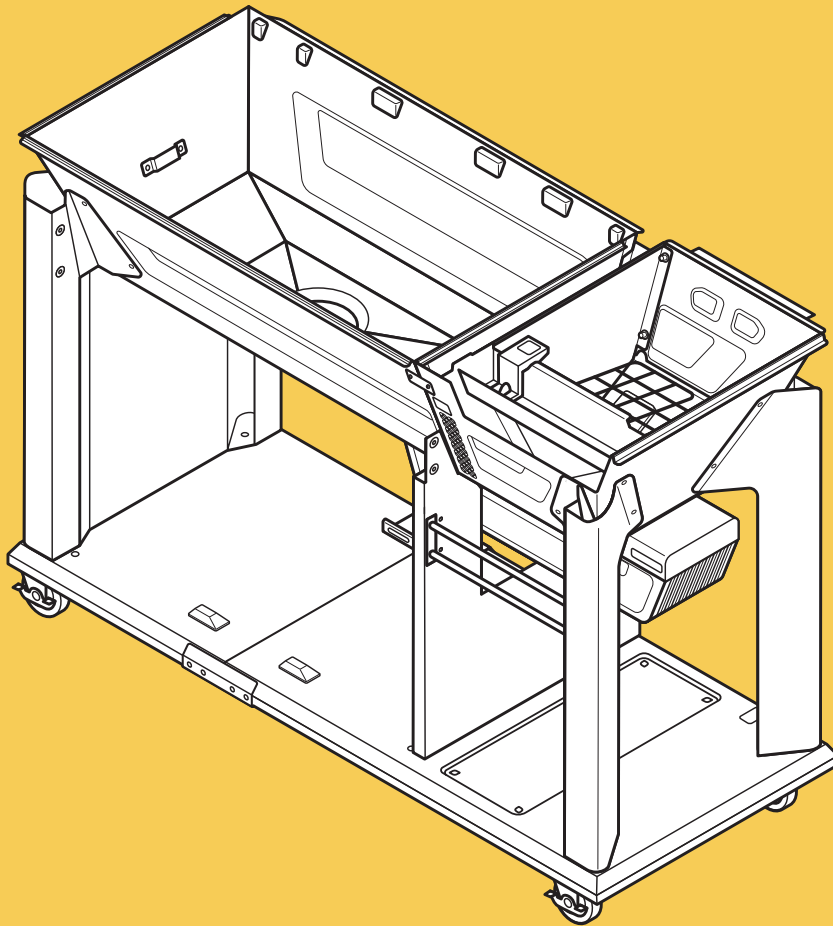

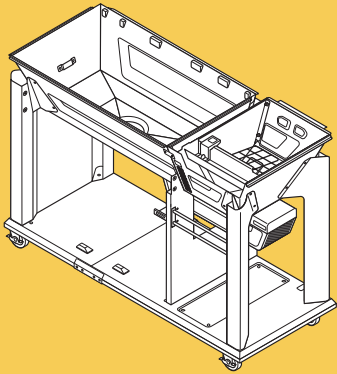

ARMOIRE ET ROULETTES

CHAPITRE 2

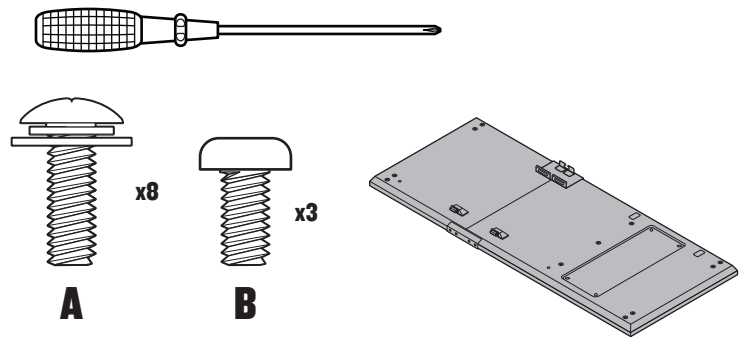

1 MONTER LA BASE



 **CONSEIL DE PRO :** serrez d'abord toutes les vis à la main, puis terminez le serrage avec un tournevis.

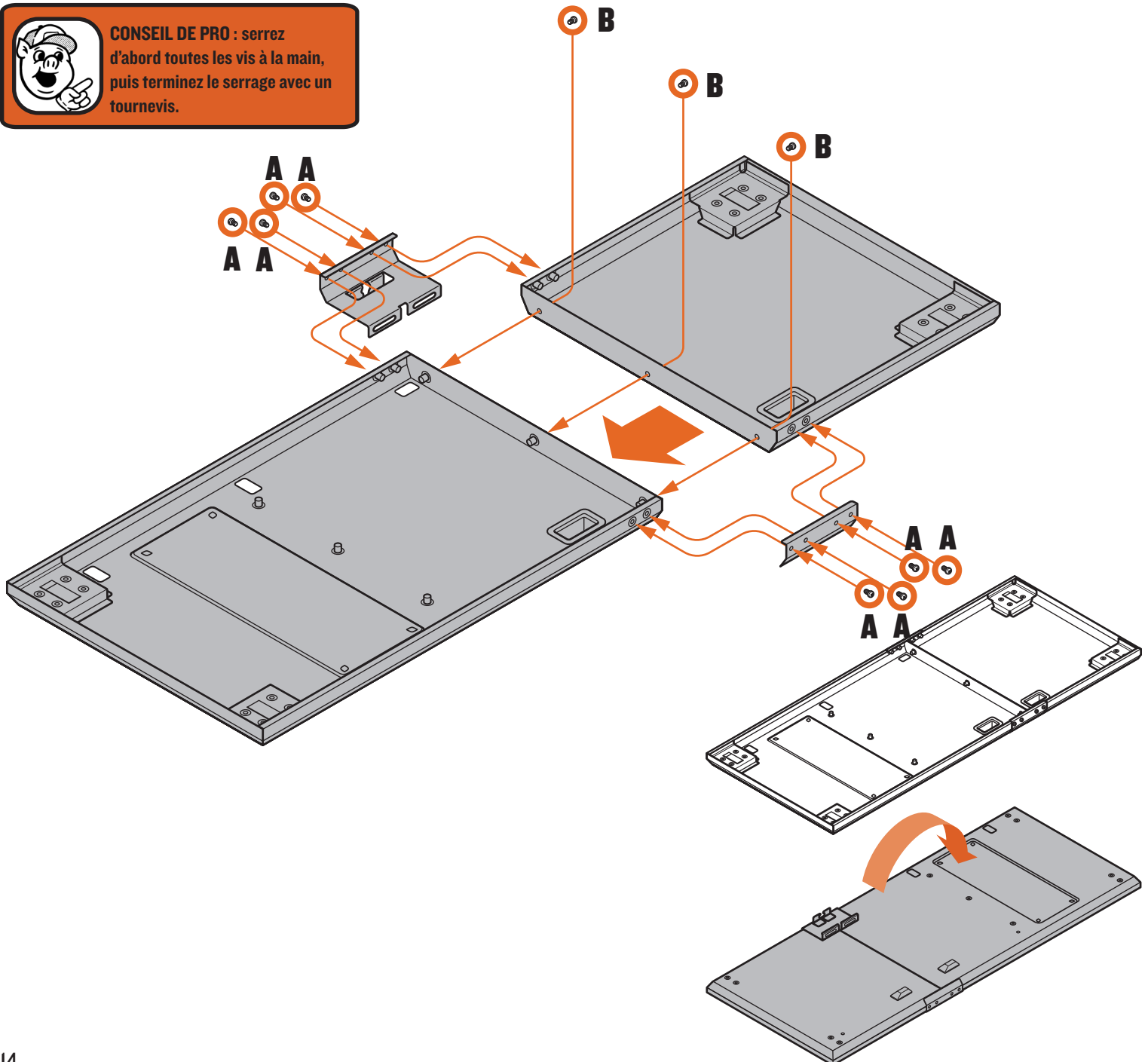



2 FIXER LA PAROI CENTRALE

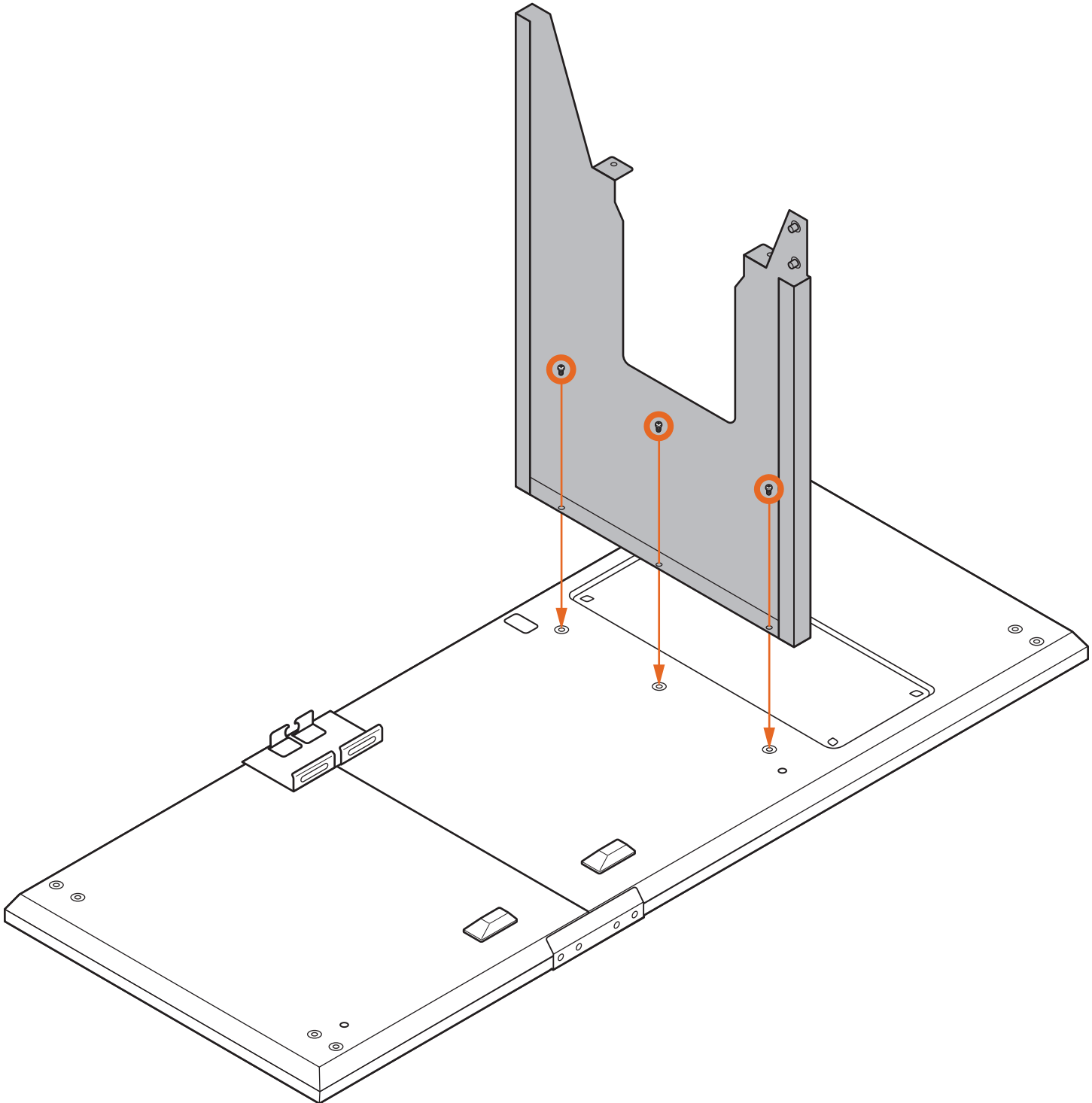
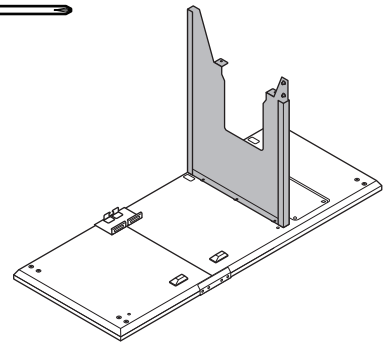
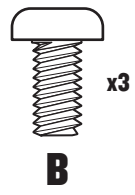
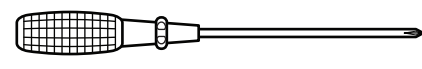



 **CONSEIL DE PRO :** Demandez à une deuxième personne de vous aider à soulever et à faire pivoter la base.

3A FIXER LA BASE AU CORPS DU BARBECUE

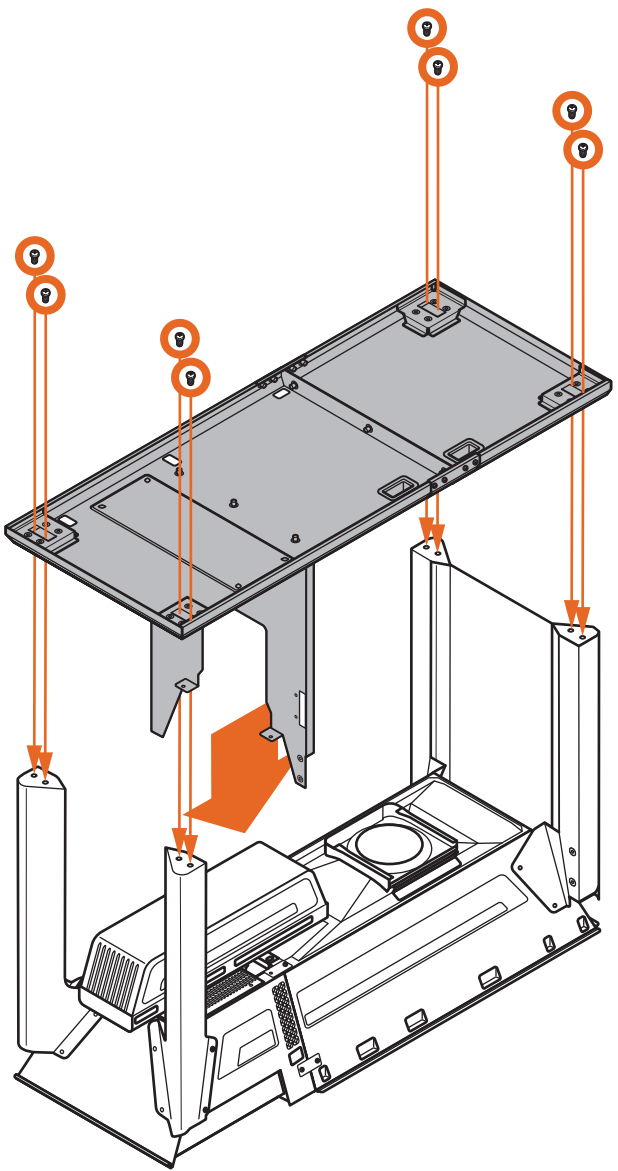
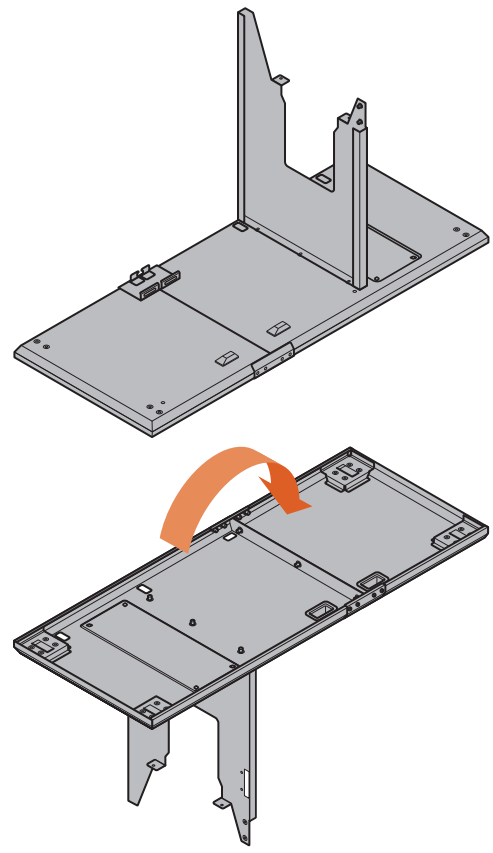
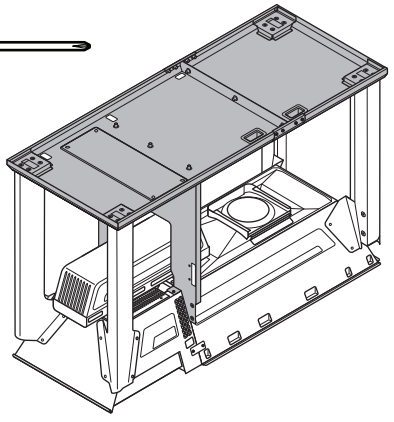
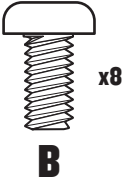
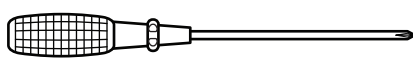



3B FIXER LA BASE AU CORPS DU BARBECUE

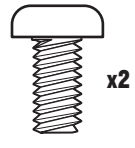
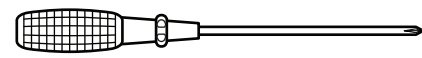

B

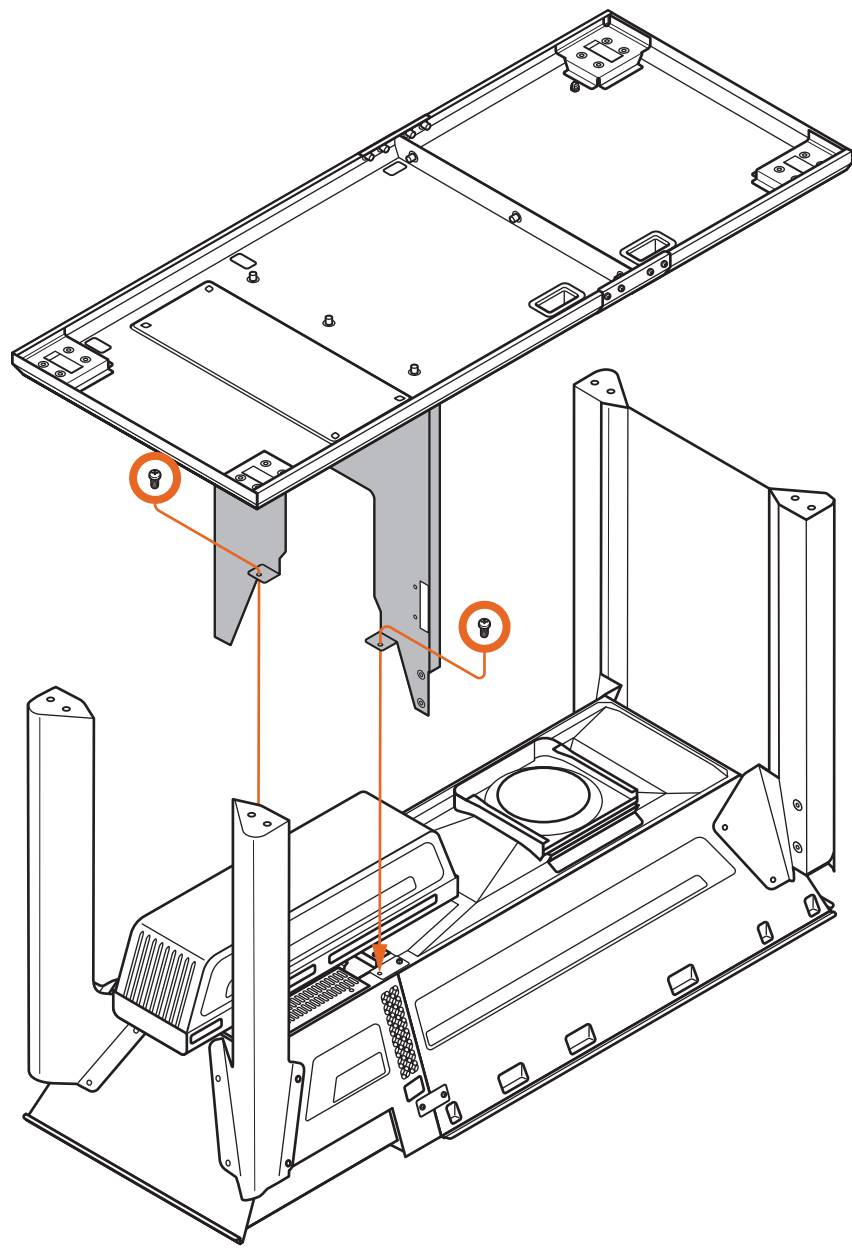
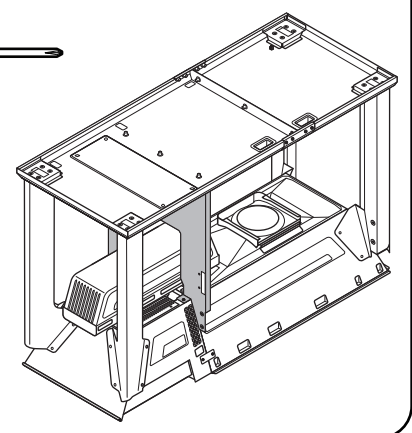



CONSEIL DE PRO : demandez à une deuxième personne de vous aider à soulever et à faire pivoter le barbecue.

4 FIXER LES ROULETTES

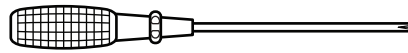

Utilisez **CETTE** vis encore une fois !

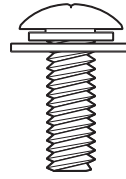

x16

A

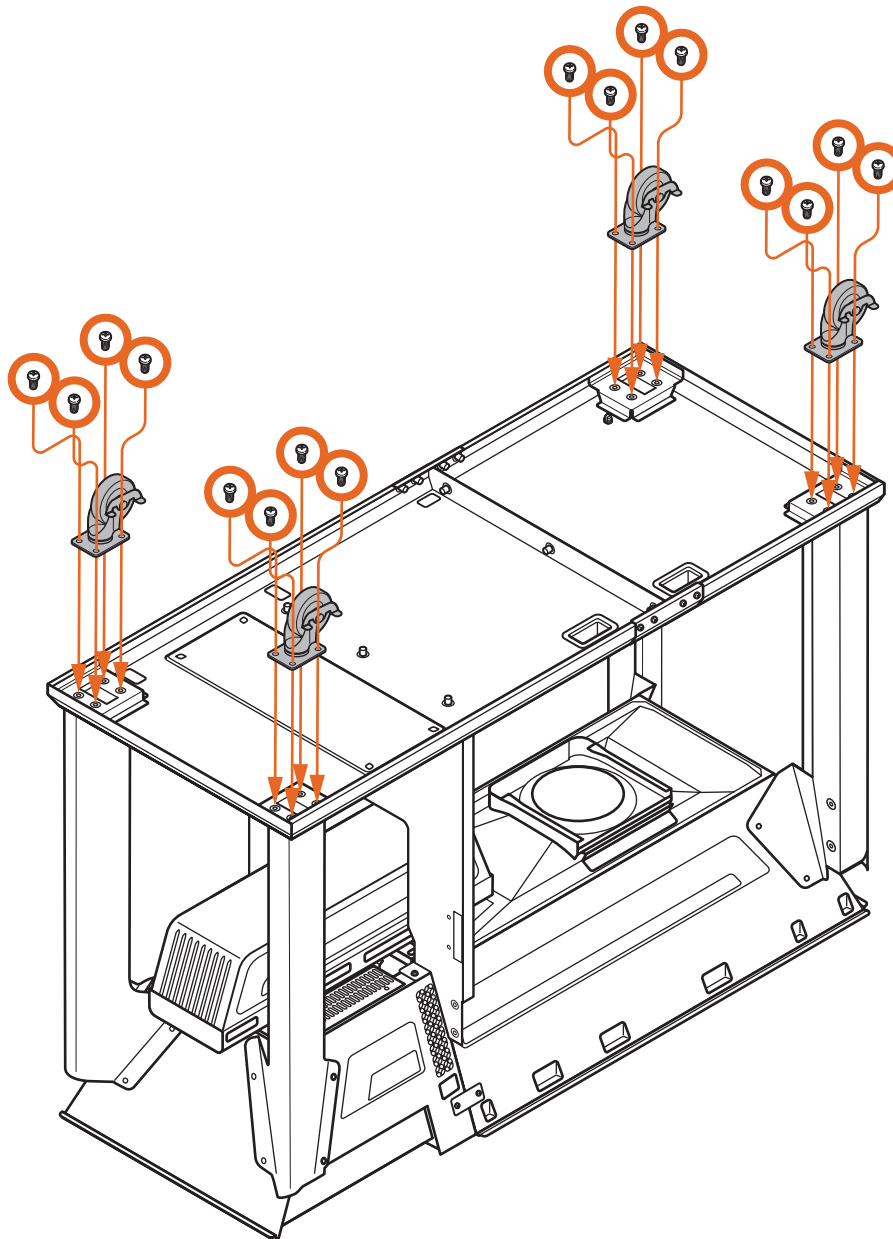
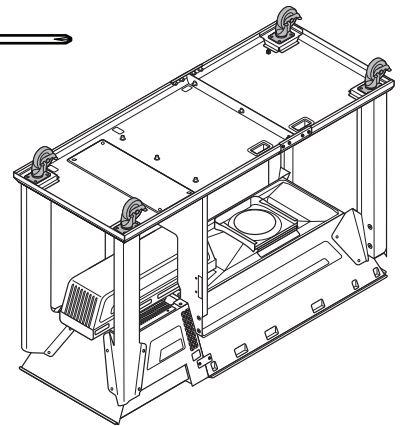



 **CONSEIL DE PRO :** demandez à une deuxième personne de vous aider à soulever et à faire pivoter le barbecue.

5 RETOURNER LE BARBECUE

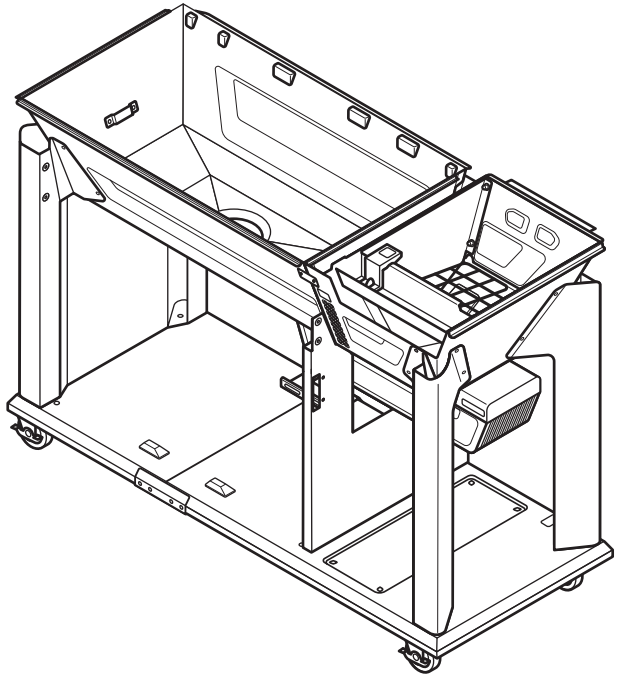
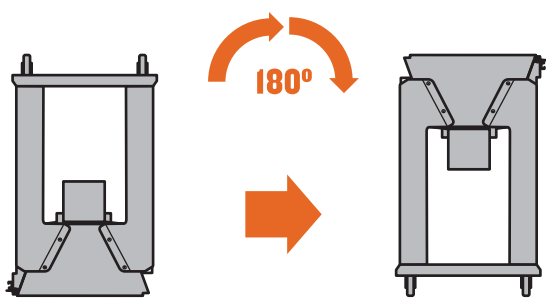
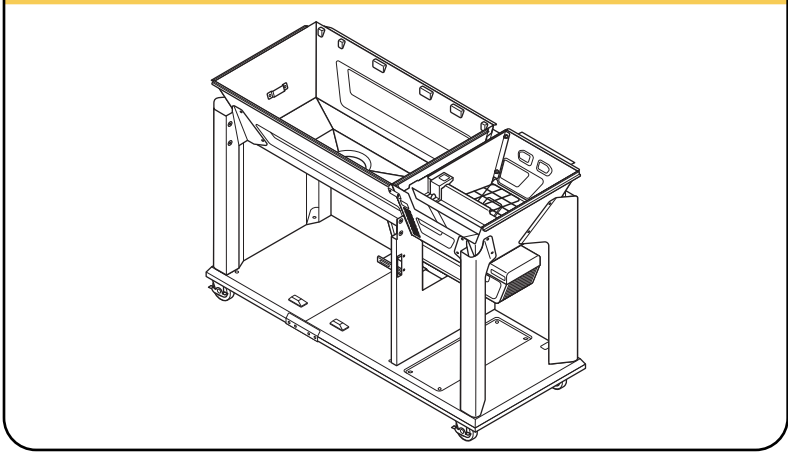

 **CONSEIL DE PRO :** verrouillez les roulettes pour empêcher le barbecue de rouler.



CONSEIL DE PRO :
si vous avez besoin
d'aide pour cette
étape, scannez ce code
QR pour obtenir nos
instructions animées.



6 FIXER LE SUPPORT MULTIFONCTION P.A.L.

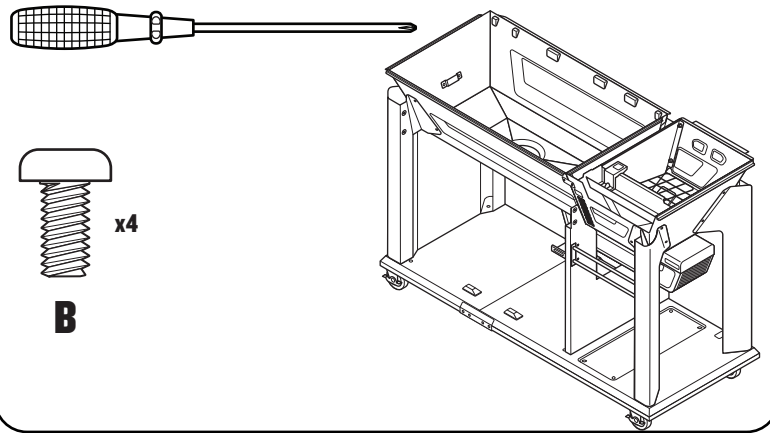

6A

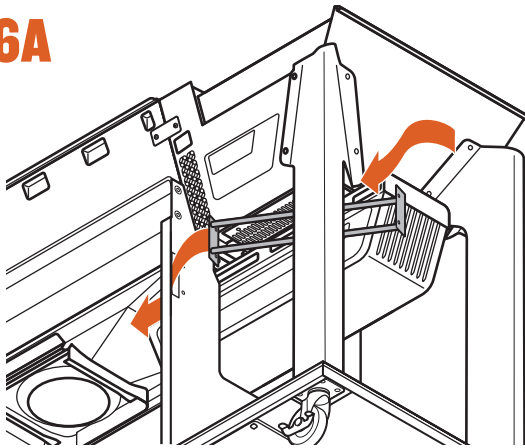

6B

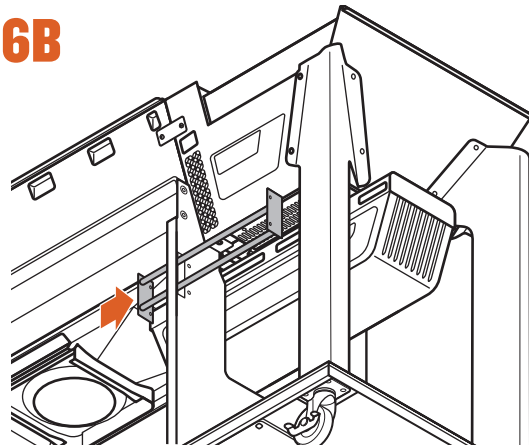

6C

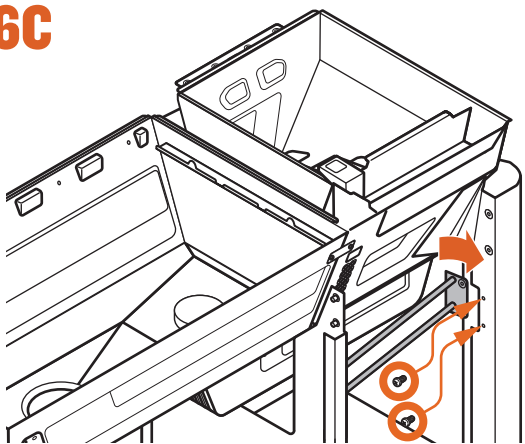

6D

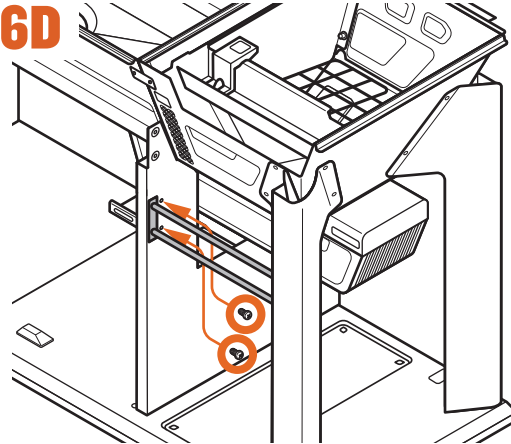

**BEAU TRAVAIL !
CHAPITRE 2 TERMINÉ !**

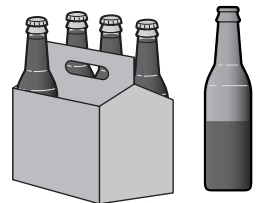

CHAPITRE 3

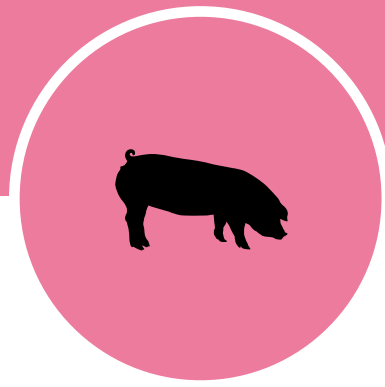
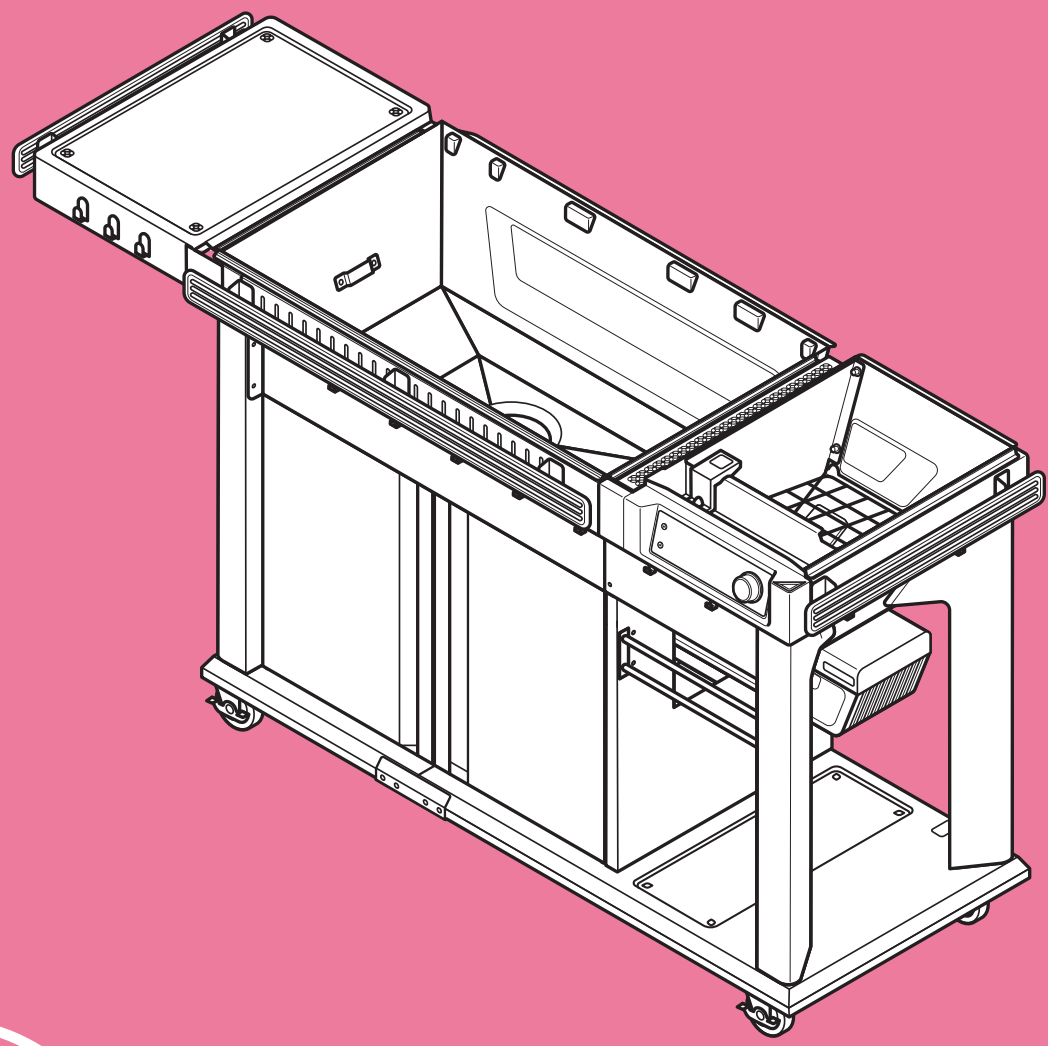

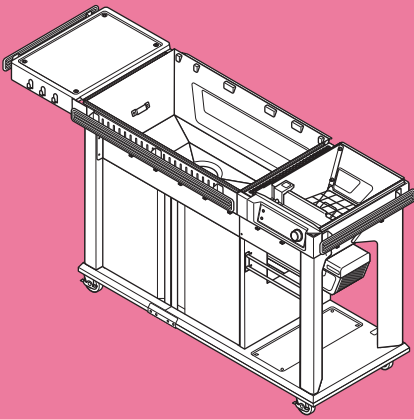

ÉTAGÈRE LATÉRALE PLIANTE, BASE ET PANNEAU DE COMMANDE

CHAPITRE 3

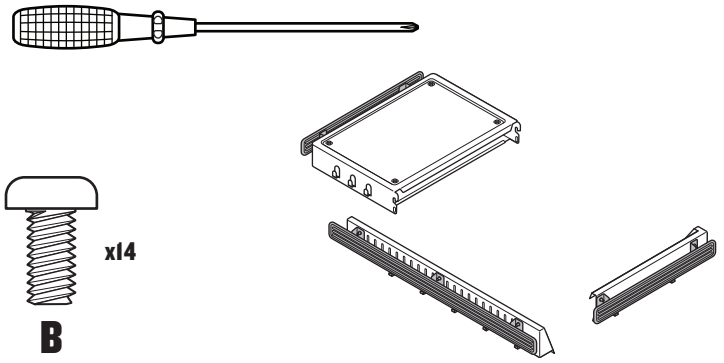

I MONTER LES RAILS P.A.L.



 **CONSEIL DE PRO :** serrez d'abord toutes les vis à la main, puis terminez le serrage avec un tournevis.

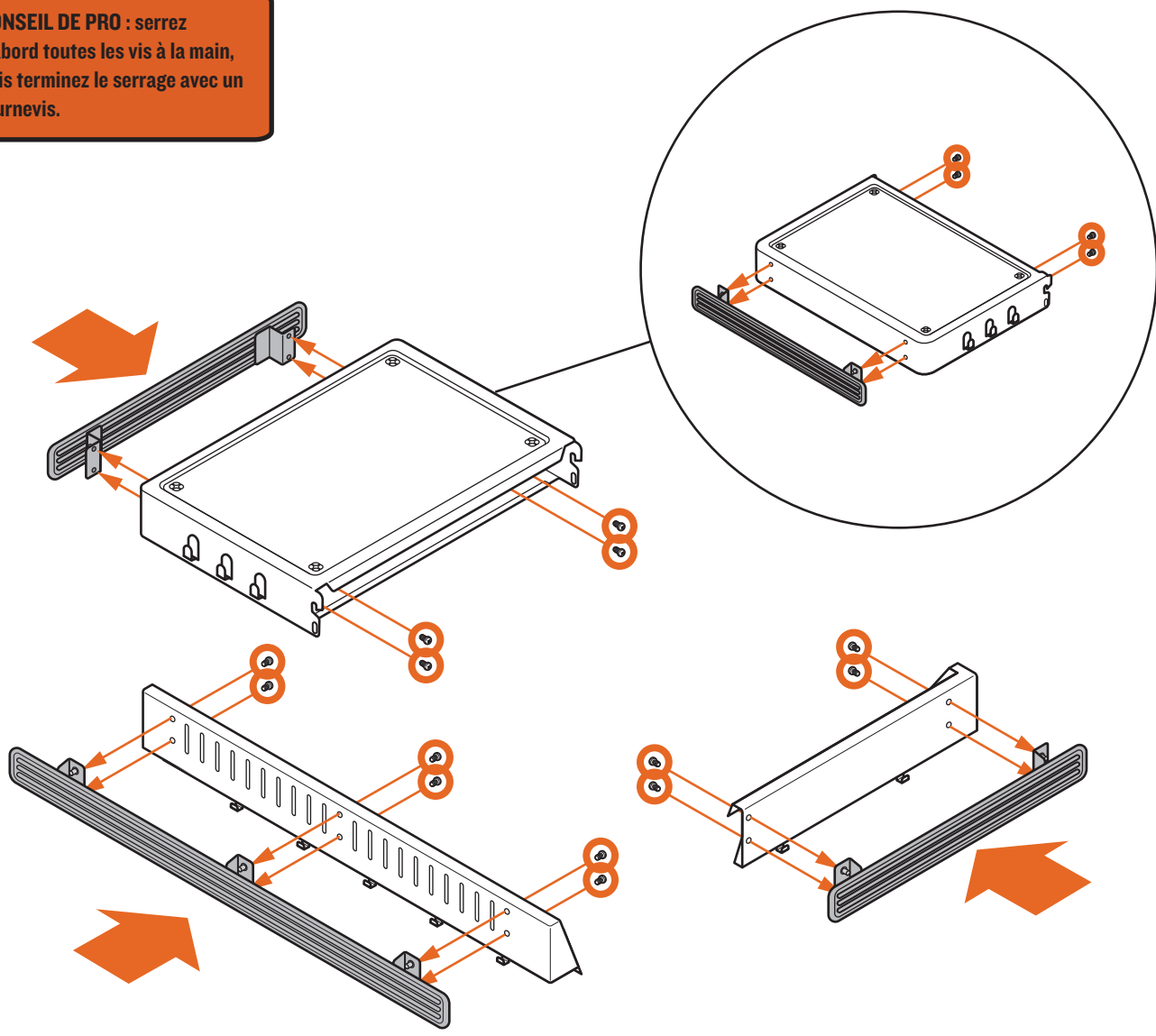



CONSEIL DE PRO : cette étape peut être délicate. Scannez notre code QR pour accéder aux animations vidéo de montage. Passez au chapitre 3, Étape 2 pour voir une vidéo.





CONSEIL DE PRO : Pour éviter que le matériel ne tombe dans le boîtier de la vis sans fin, posez ce manuel sur la grille.

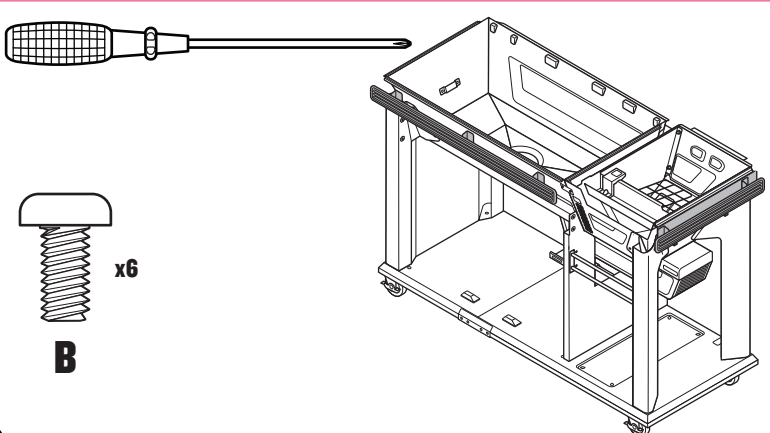
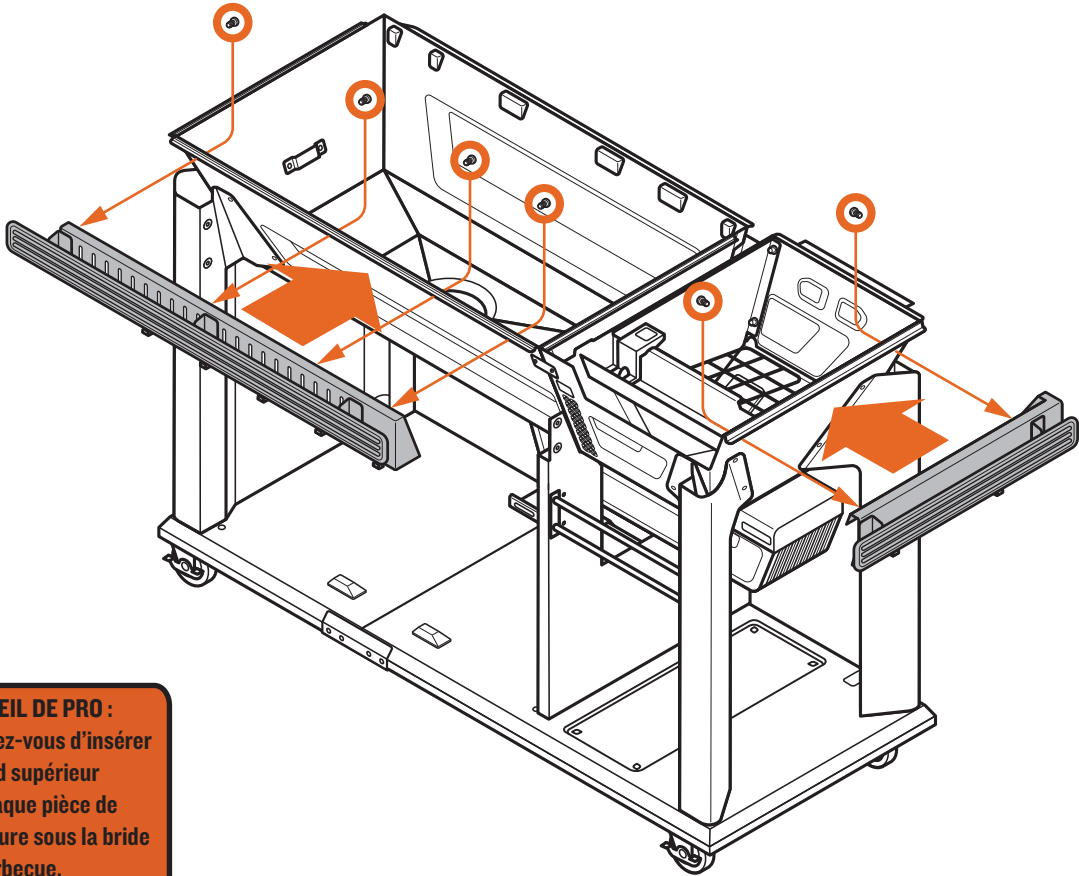

2 FIXER LA GARNITURE DU P.A.L.

CONSEIL DE PRO : assurez-vous d'insérer le bord supérieur de chaque pièce de garniture sous la bride du barbecue.

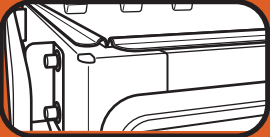



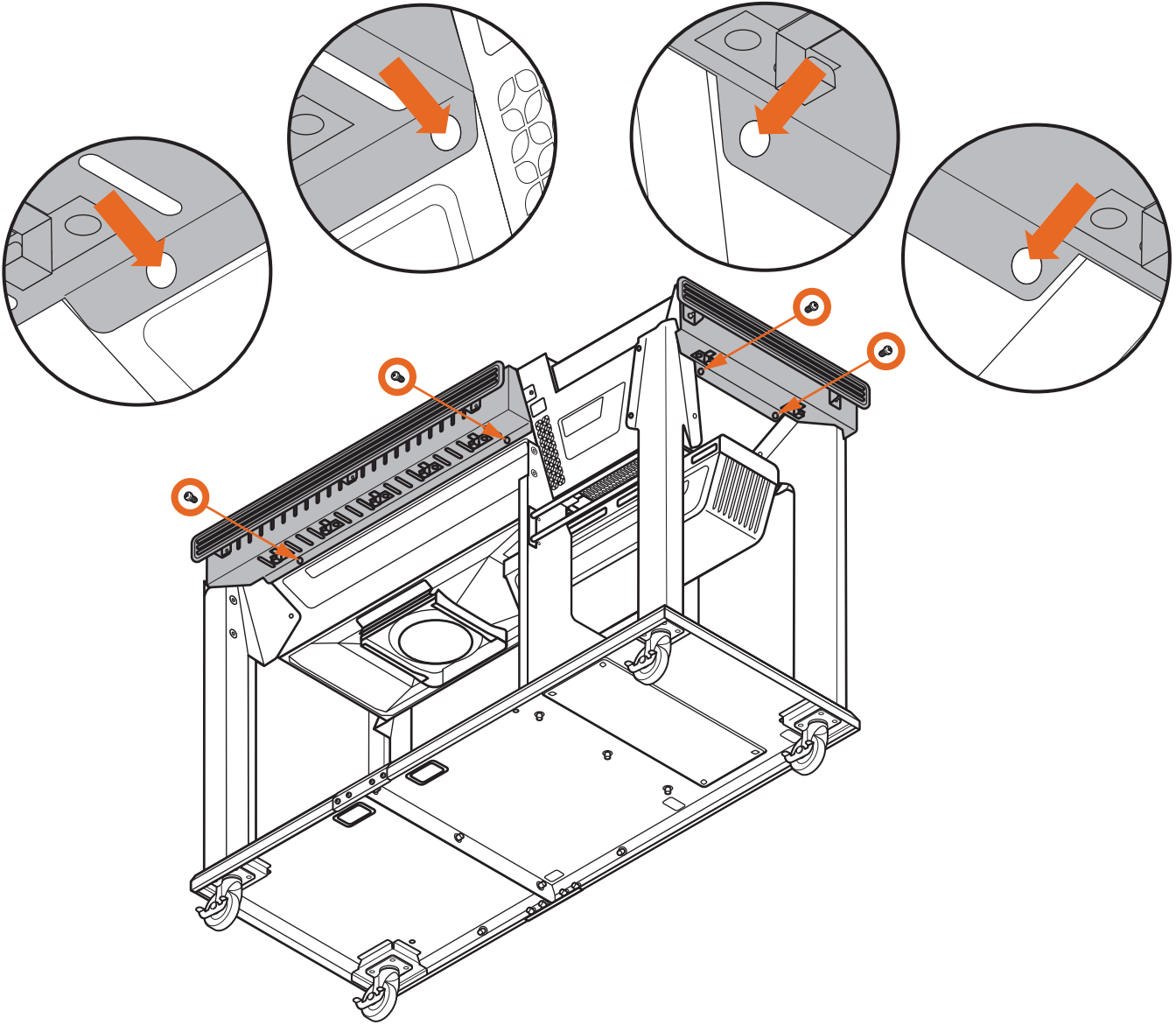

3 SÉCURISER LA GARNITURE P.A.L.

B x4



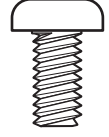
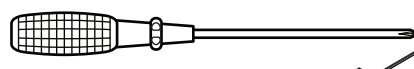

4A FIXER L'ÉTAGÈRE LATÉRALE PLIANTE



B

x5

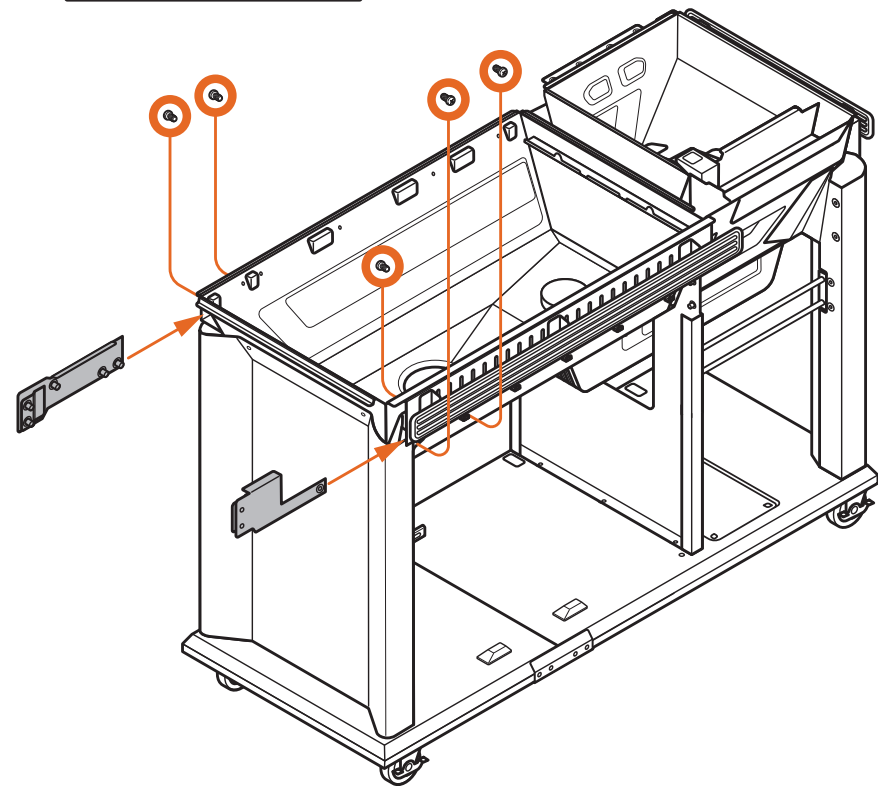
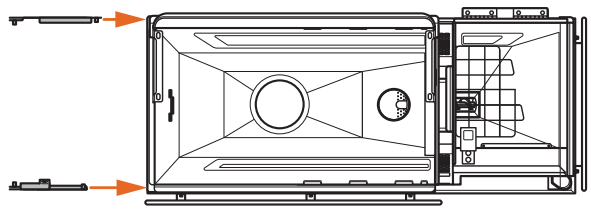
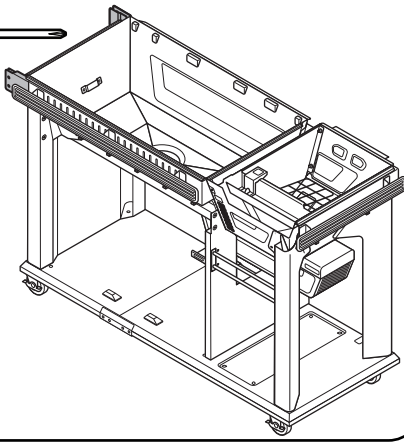
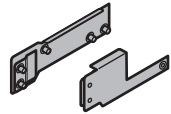



CONSEIL DE PRO : serrez
d'abord toutes les vis à la main,
puis terminez le serrage avec
un tournevis.

4B FIXER L'ÉTAGÈRE LATÉRALE PLIANTE

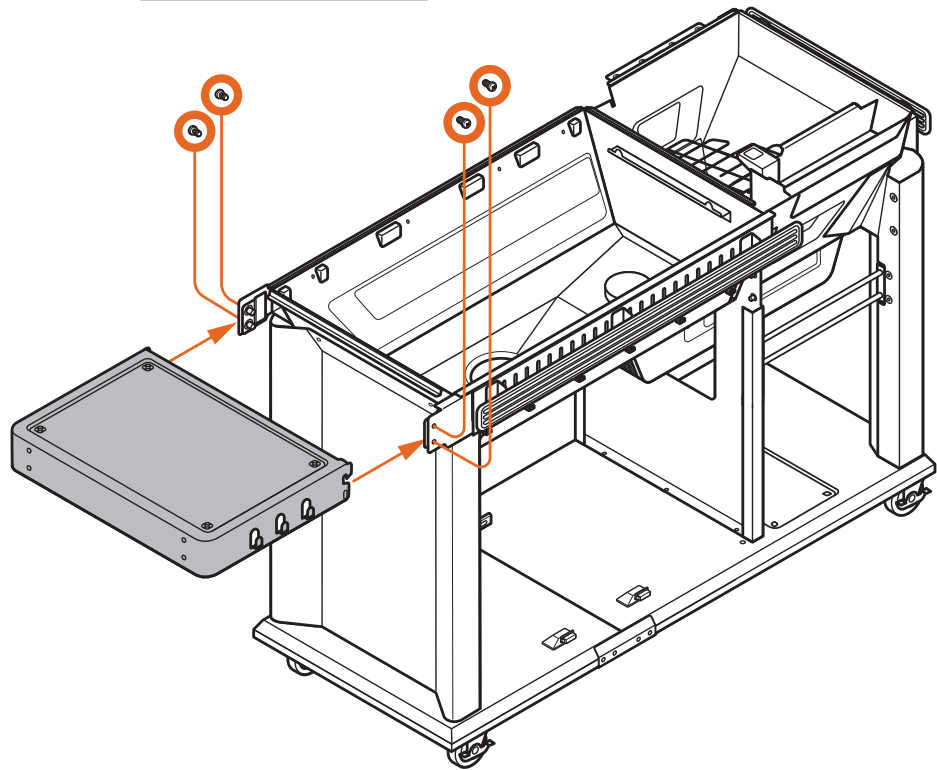
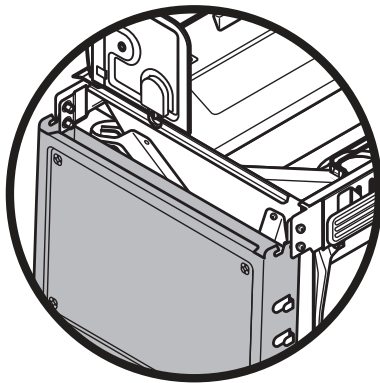
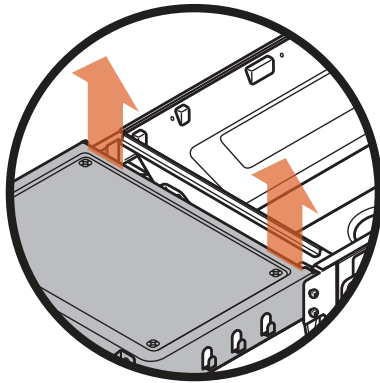
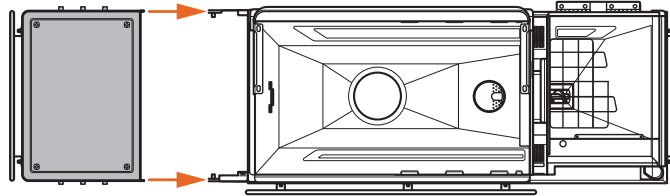
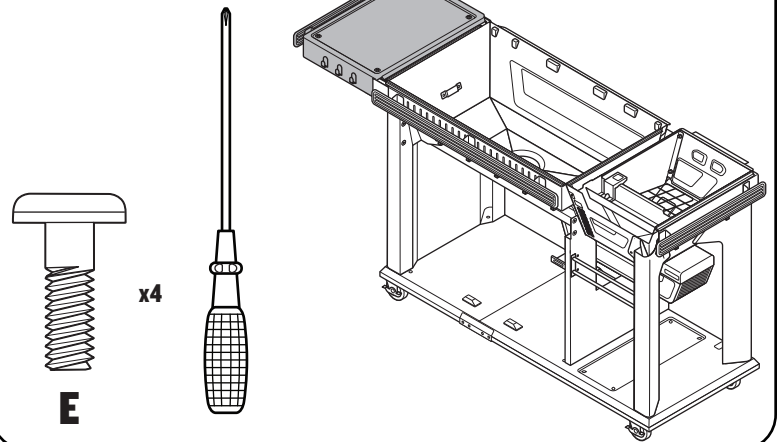



 **CONSEIL DE PRO :** demandez à une deuxième personne de vous aider à positionner les panneaux arrière.

5 MONTER LES PANNEAUX ARRIÈRE ET LA GARNITURE SUPÉRIÈRE

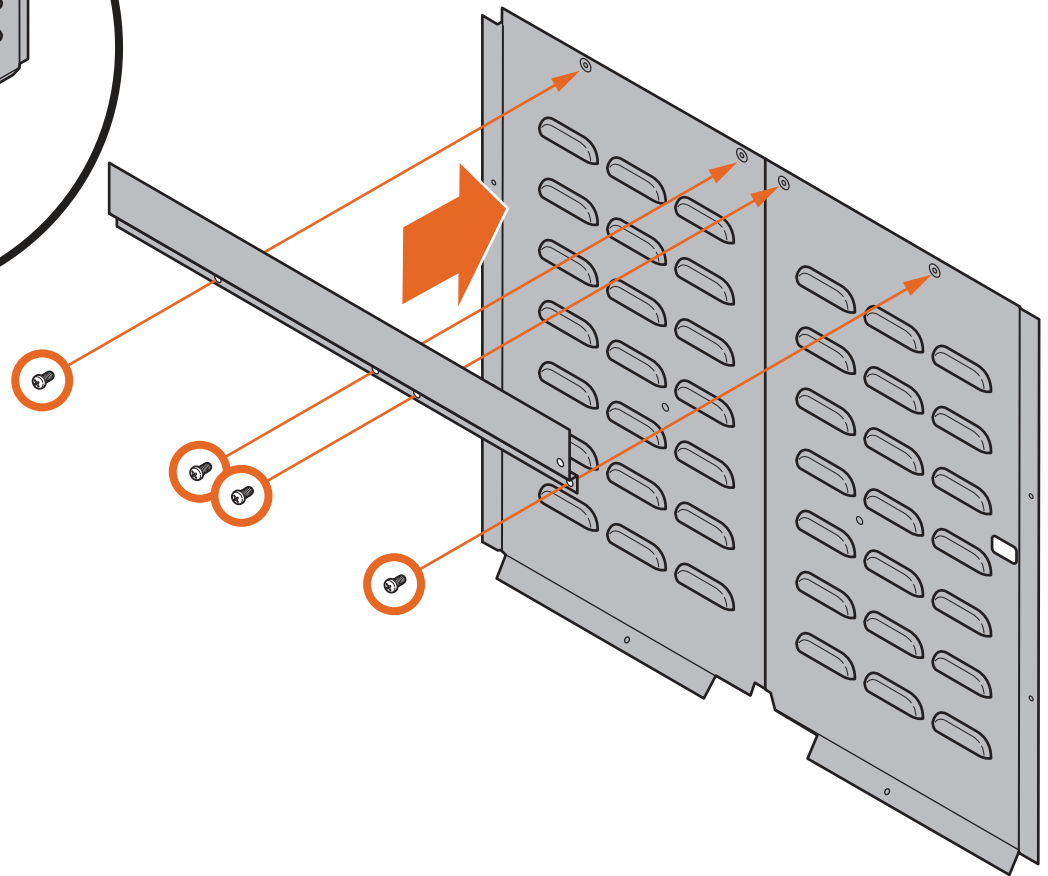
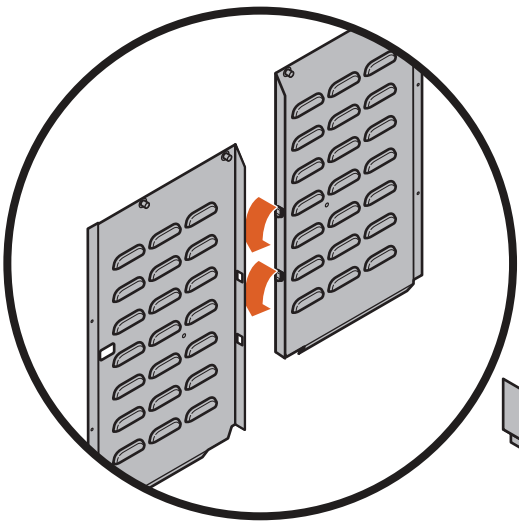
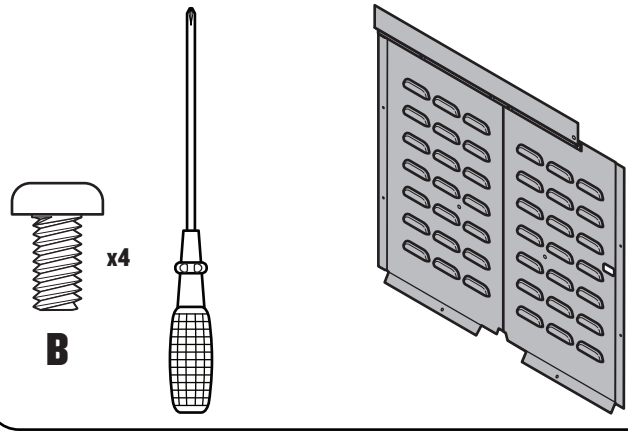



6 FIXER LA GARNITURE SUPÉRIEURE ARRIÈRE/MONTAGE DU PANNEAU ARRIÈRE

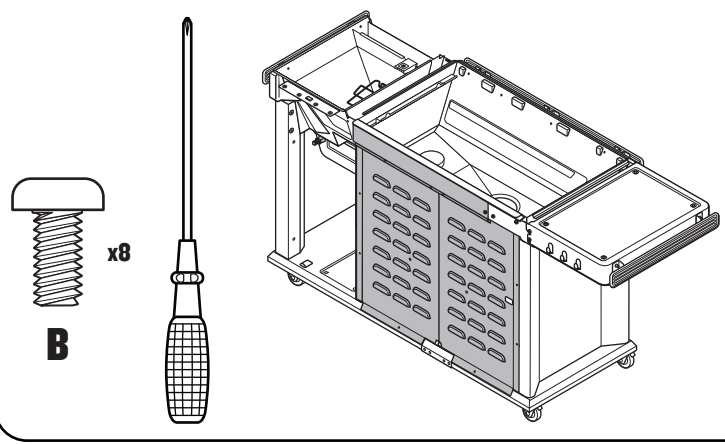

CONSEIL DE PRO : installez la vis latérale en dernier, ce faisant, poussez vers le haut sur le panneau arrière.

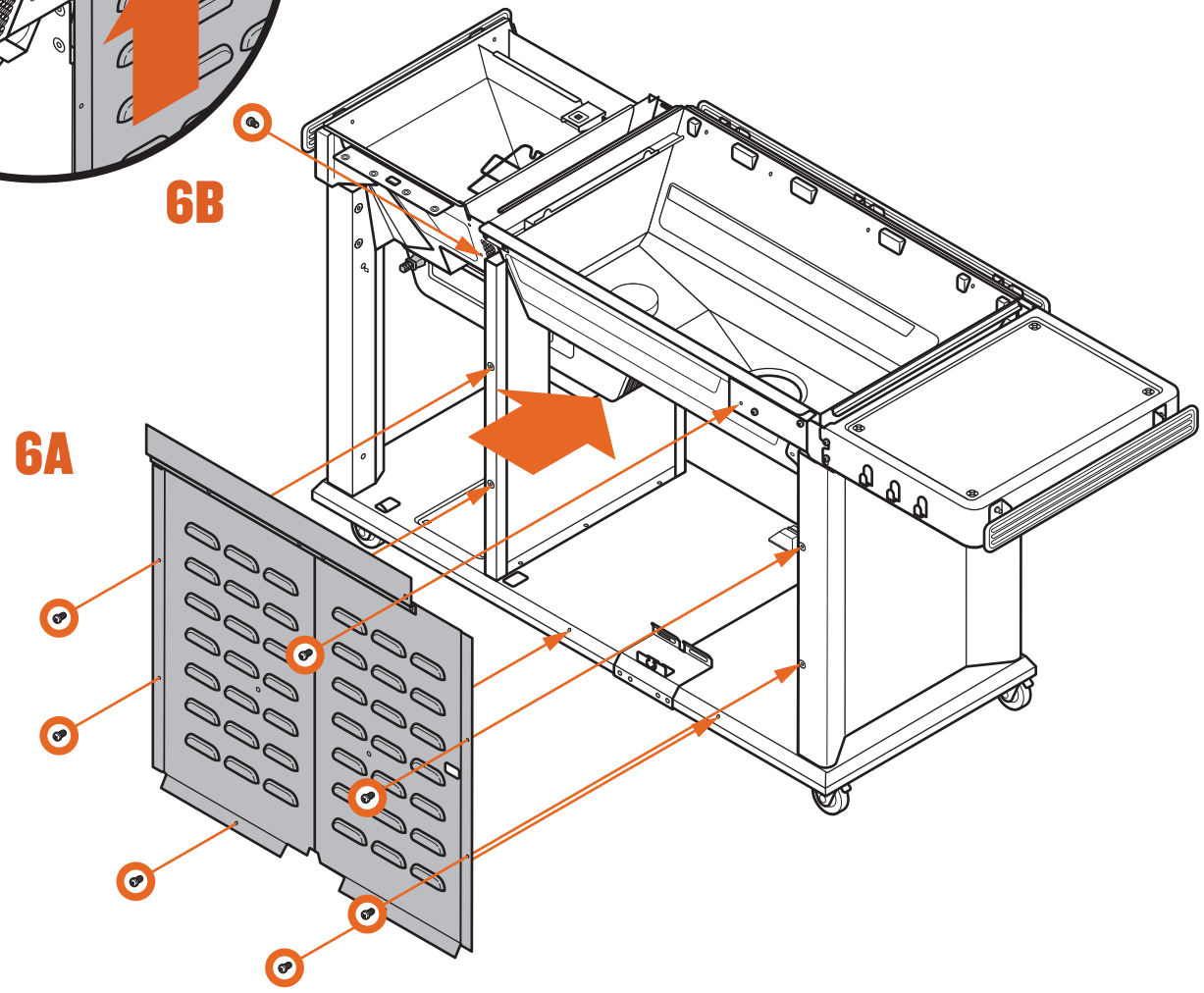



CONSEIL DE PRO : cette étape ne nécessite aucun matériel.

7 MONTER LE DOSSERET

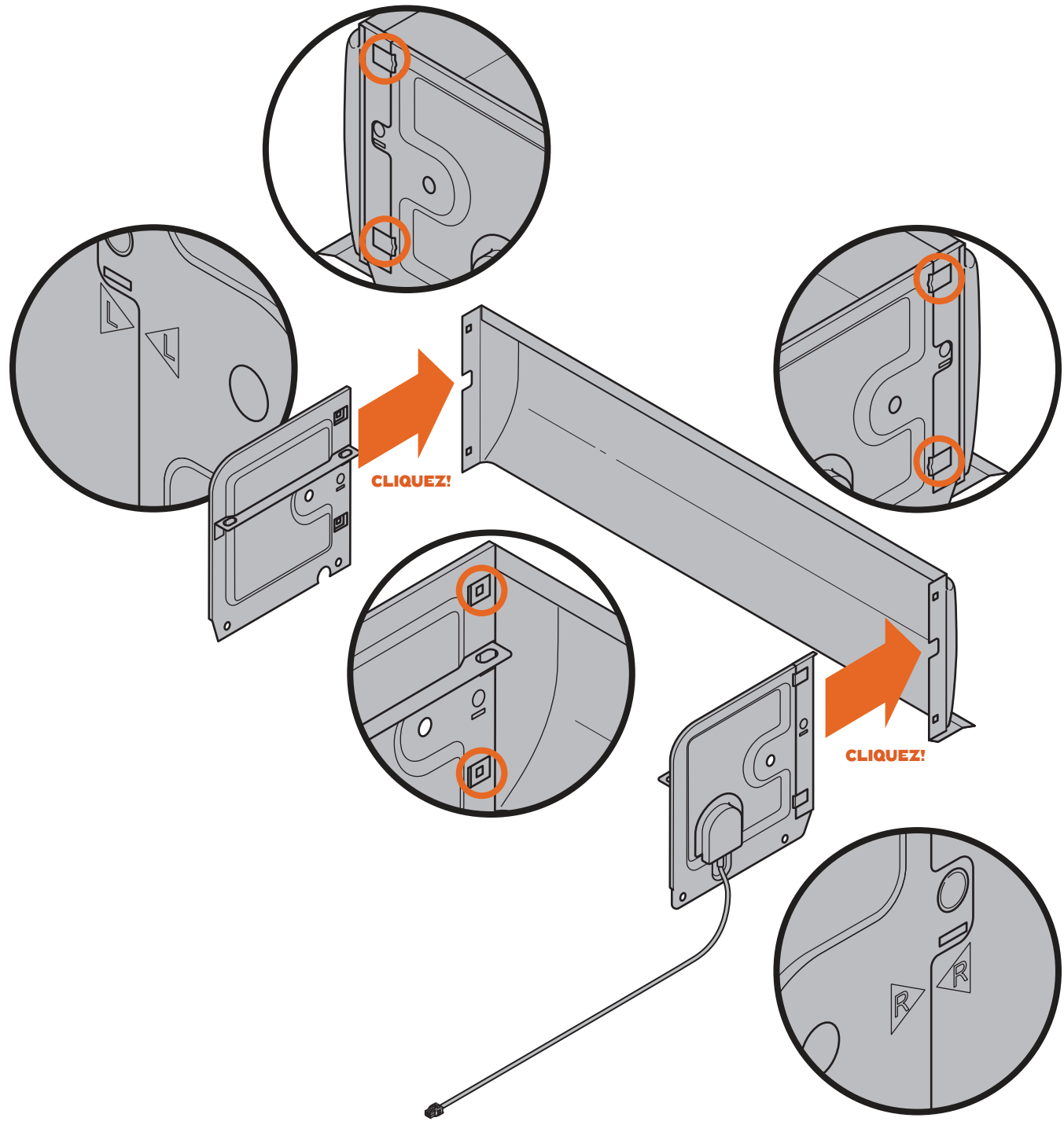
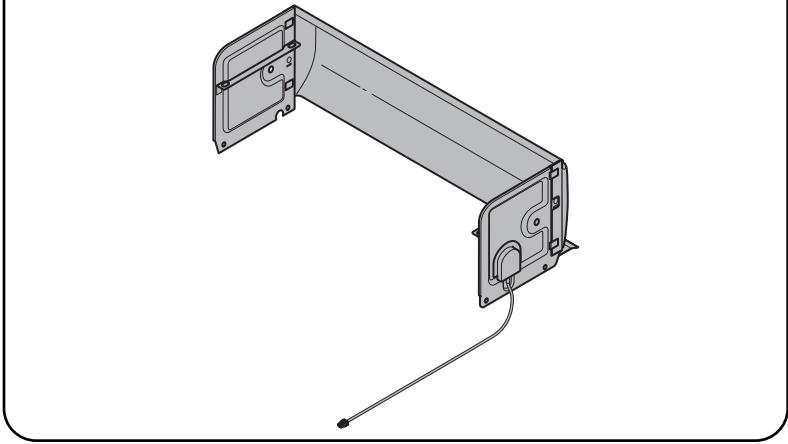



CONSEIL DE PRO : ne pincez pas le câble entre le dossieret et le corps du barbecue ! Faites également glisser le câble à travers les ouvertures avec précaution pour éviter tout dommage !

8 ACHEMINER LE CÂBLAGE DU DOSSERET

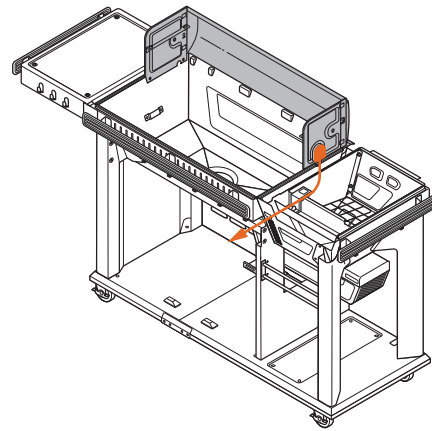

8A

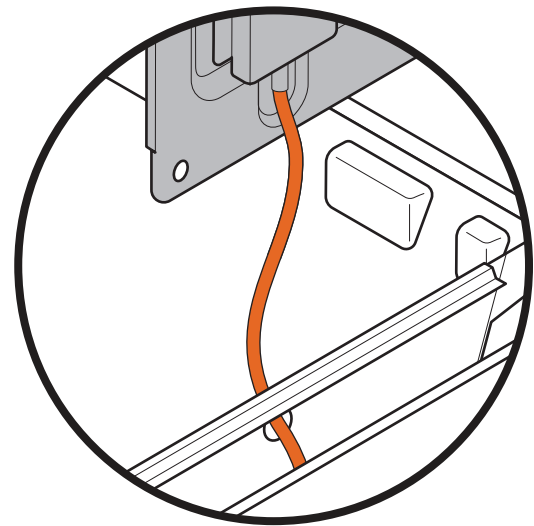
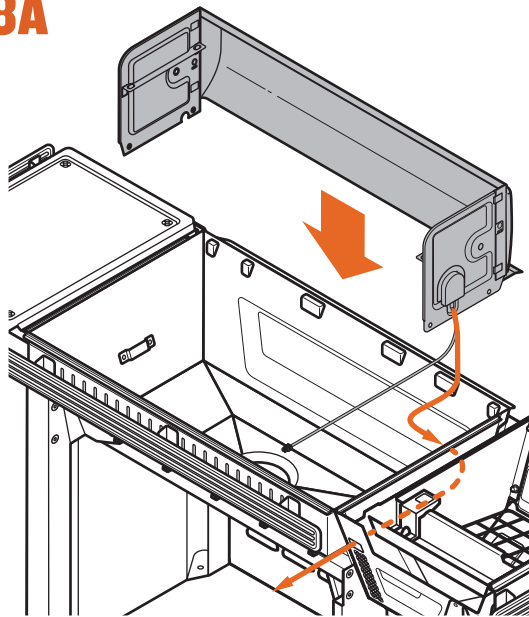

8B

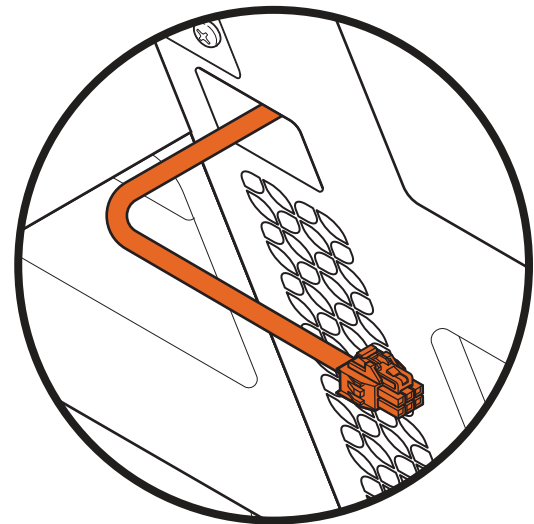
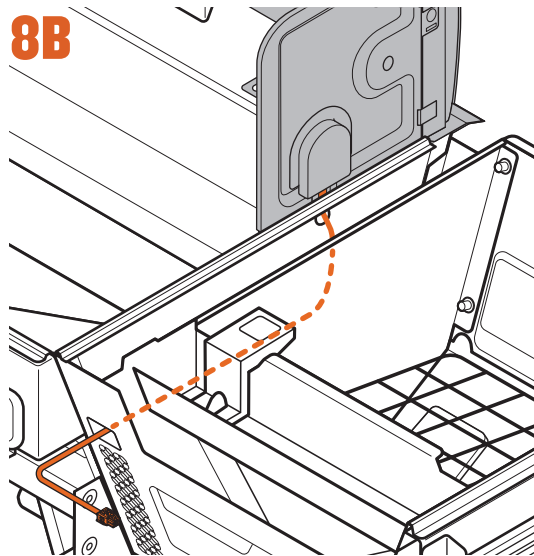



9 FIXER LE DOSSERET

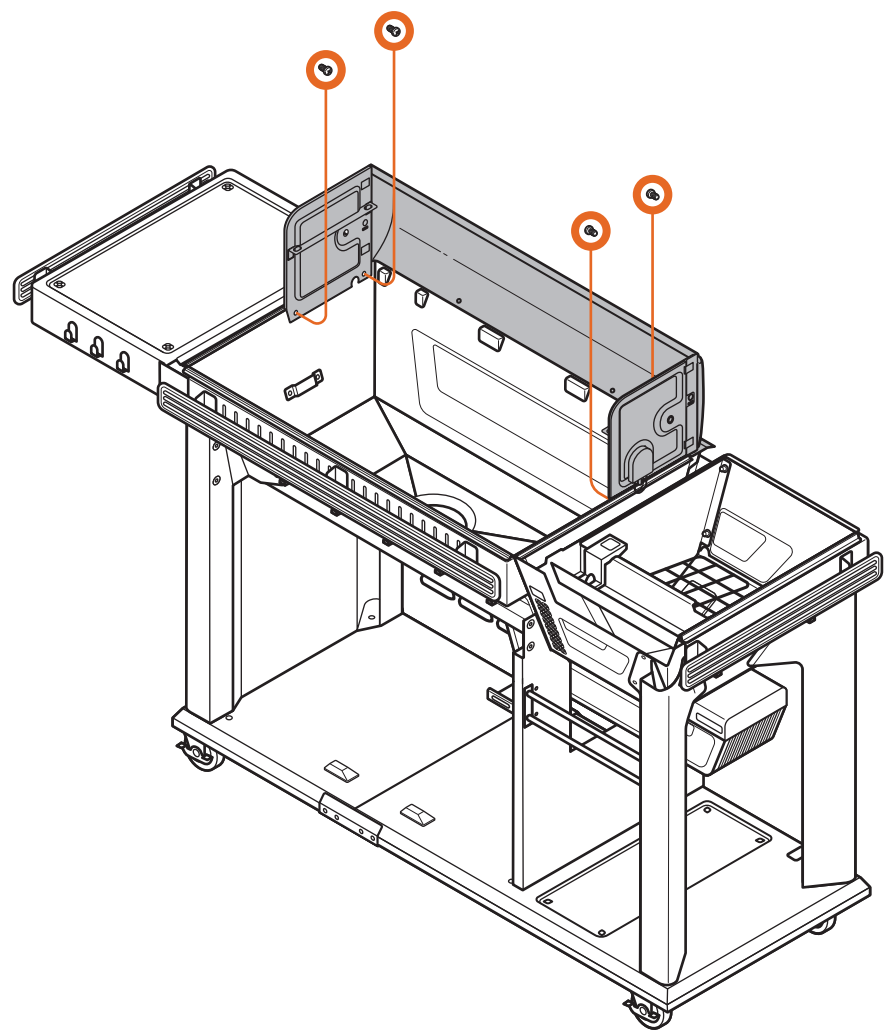
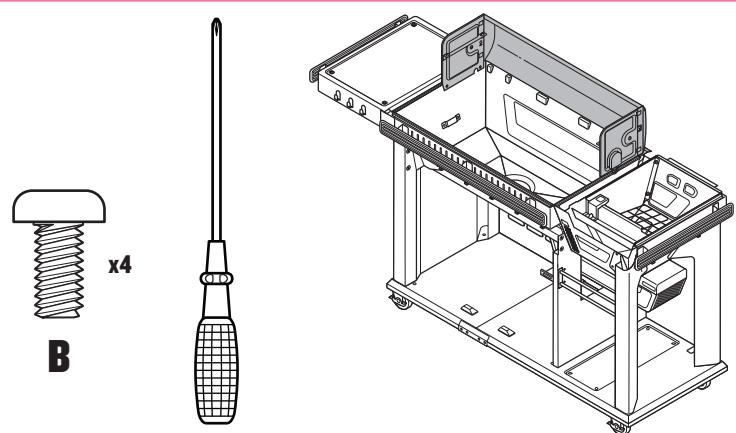



10 INSTALLER LES CROCHETS ARRIÈRE

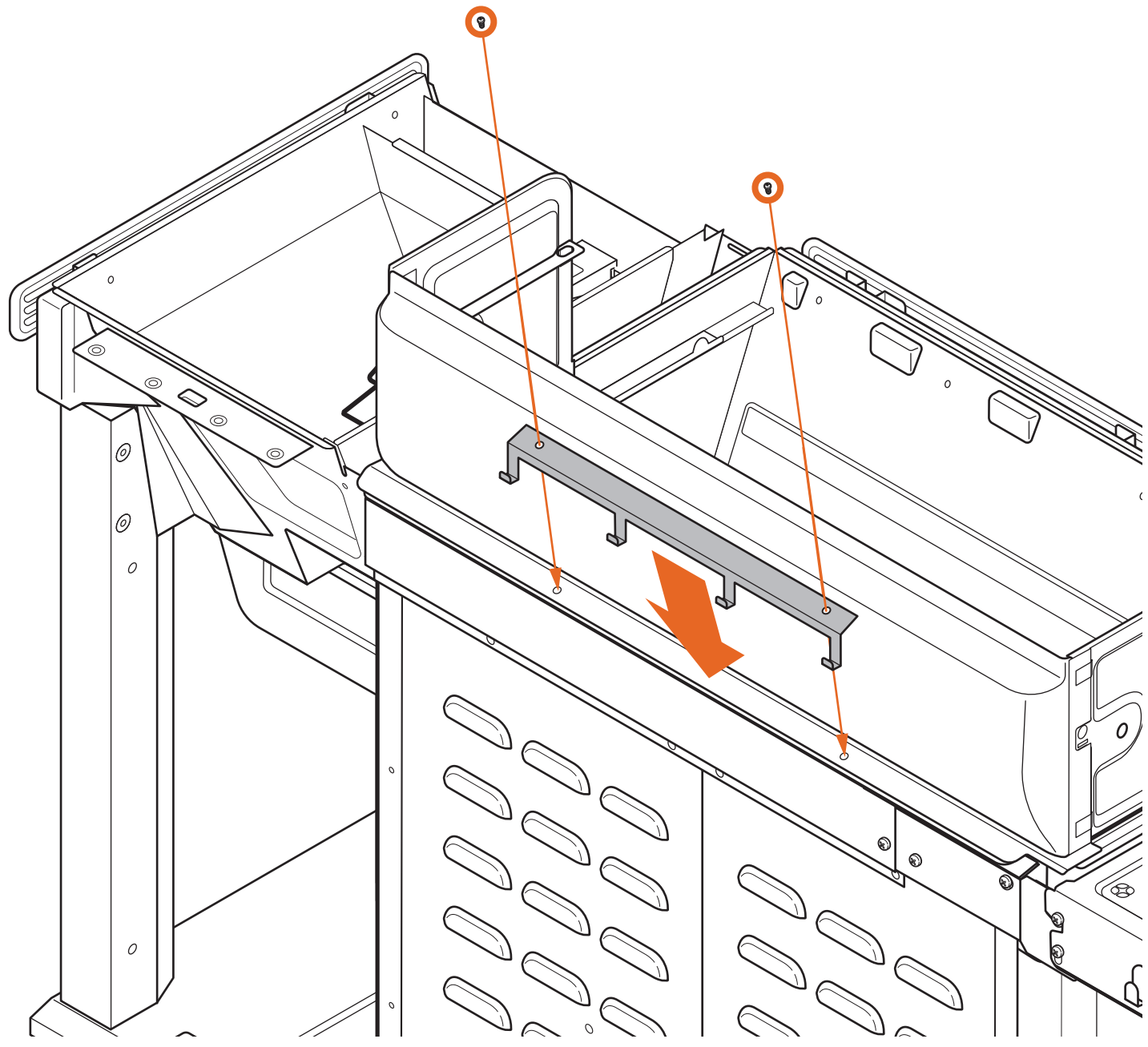
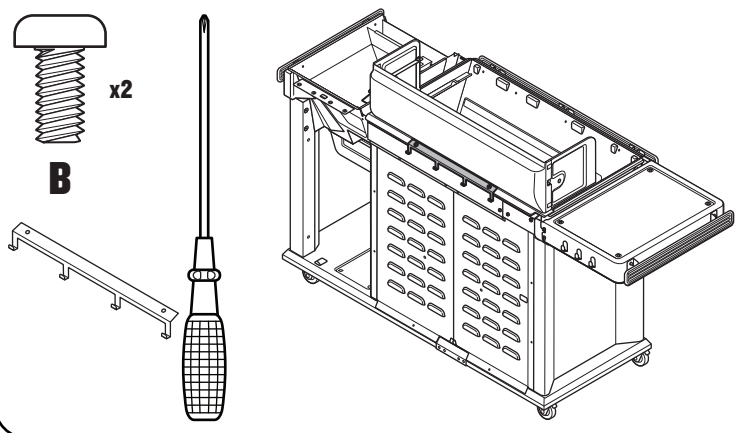



11 CONNECTER LE PANNEAU DE COMMANDE



CONNECTEUR À 4 BROCHES DU CAPTEUR RTD

CONNECTEUR À 12 BROCHES DU PANNEAU DE COMMANDE

CONNECTEUR À 6 BROCHES DU CAPTEUR DE NIVEAU DE GRANULES

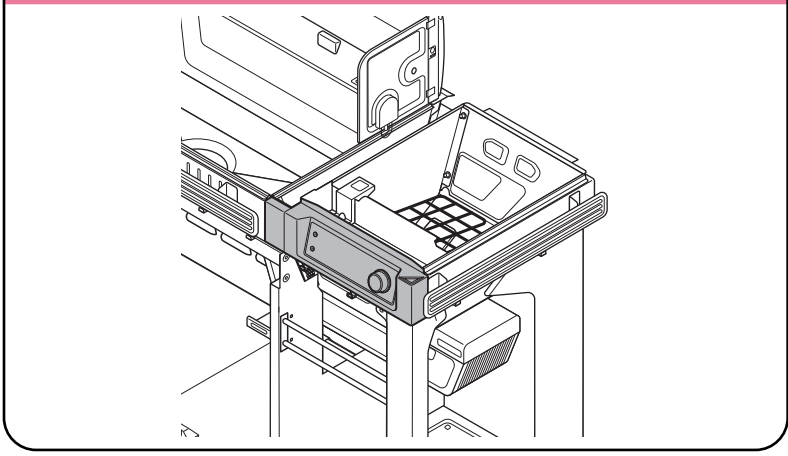
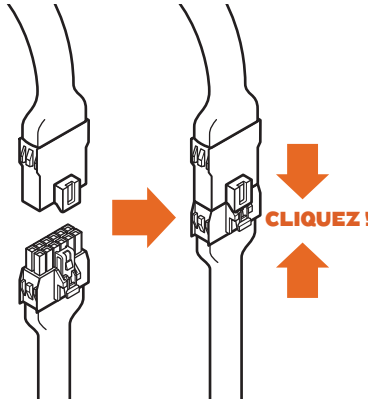

CONSEIL DE PRO : pour une connexion plus facile, posez le panneau de commande sur le dos, sur le bord de la trémie.

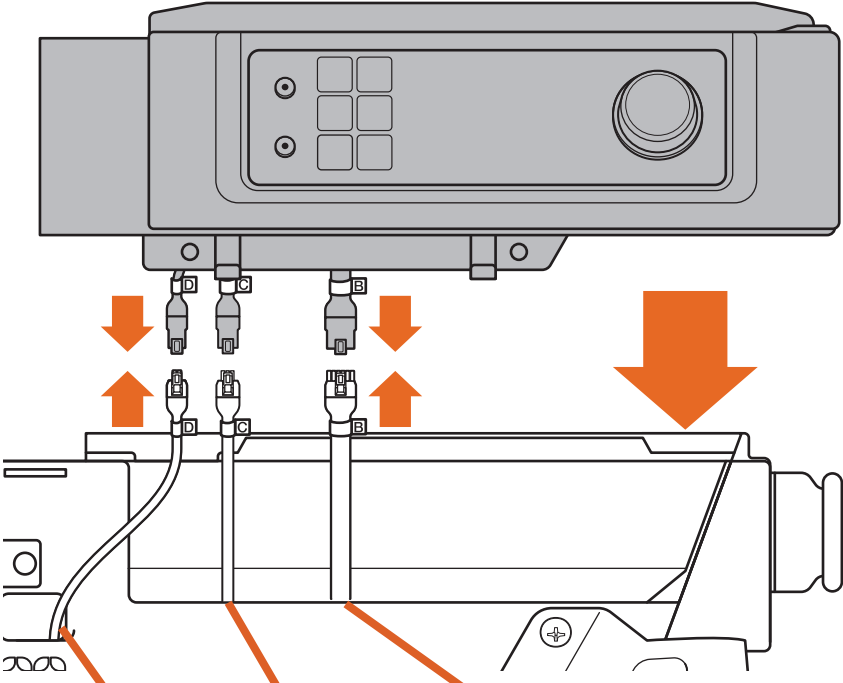
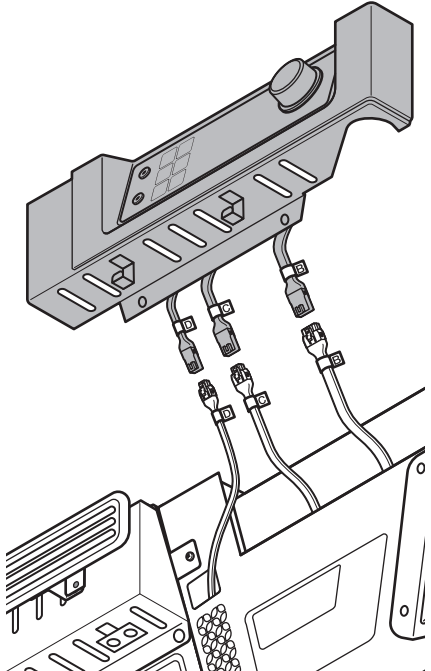

CONNECTEUR À 4 BROCHES DU CAPTEUR RTD

CONNECTEUR À 6 BROCHES DU CAPTEUR DE NIVEAU DE GRANULES

CONNECTEUR À 12 BROCHES DU PANNEAU DE COMMANDE



CONSEIL DE PRO : après la connexion, remplacez les câbles dans le barbecue pour éviter de les pincer.



12A FIXER LE PANNEAU DE COMMANDE

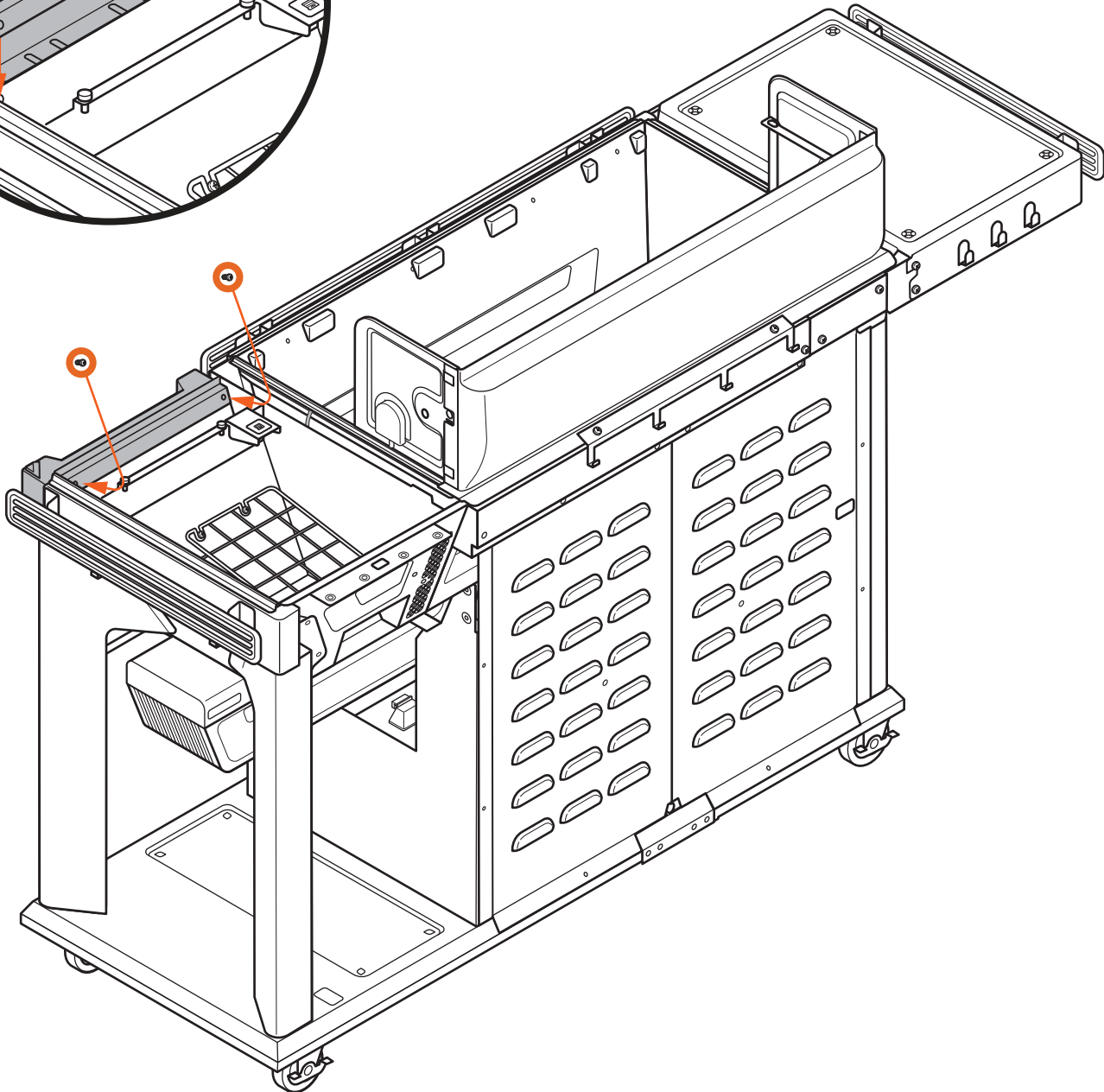
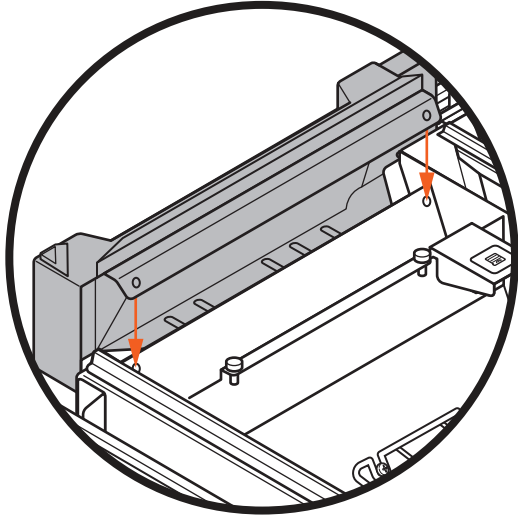
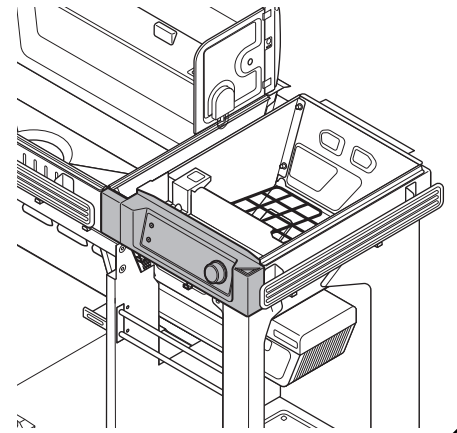
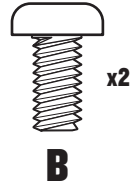

12B FIXER LE PANNEAU DE COMMANDE

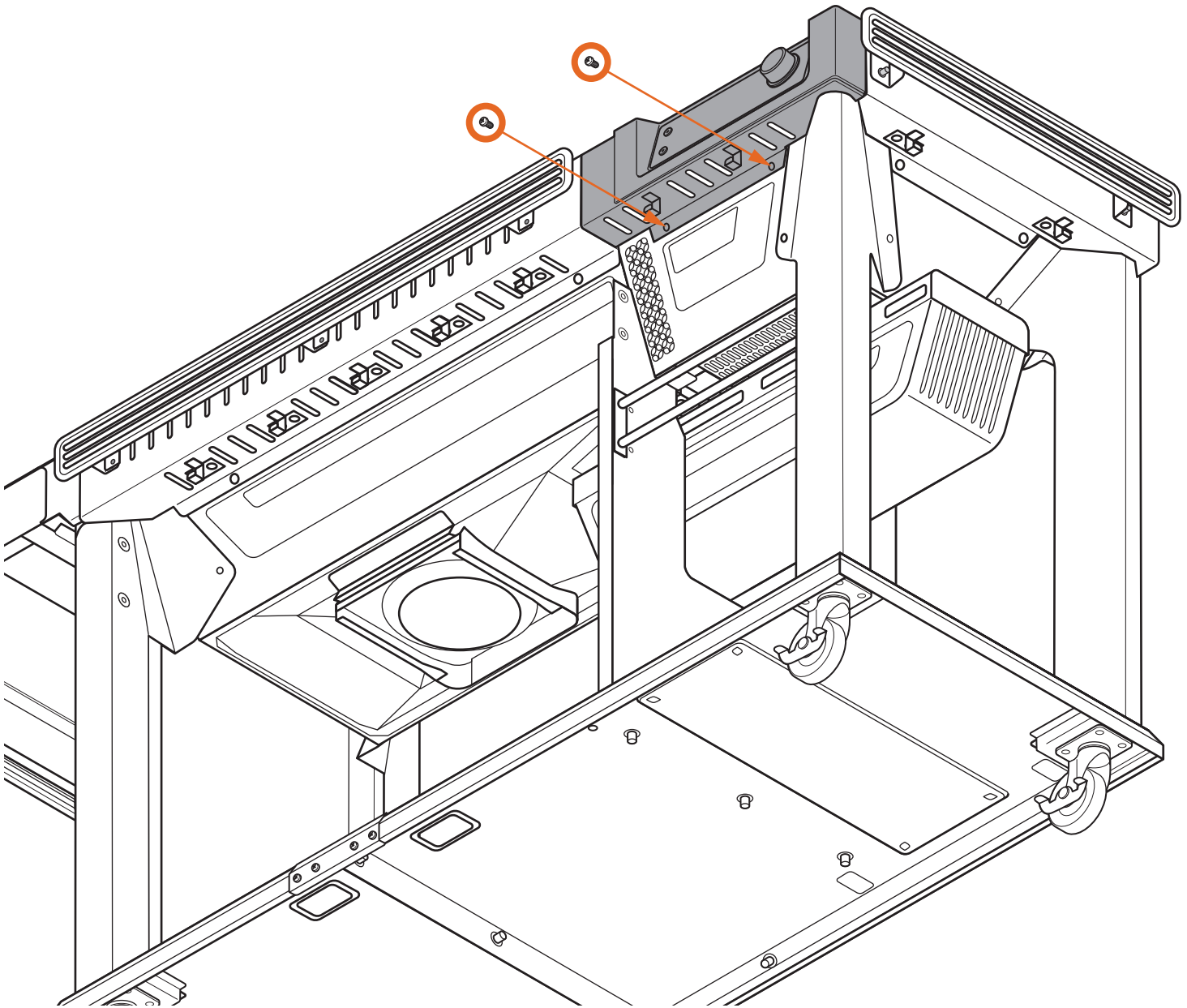
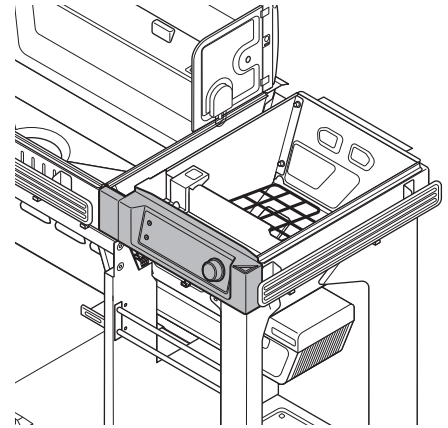
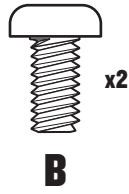



13 FIXER LA GARNITURE AVANT

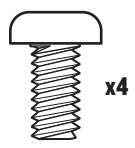
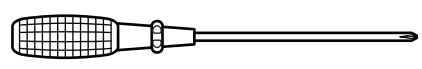

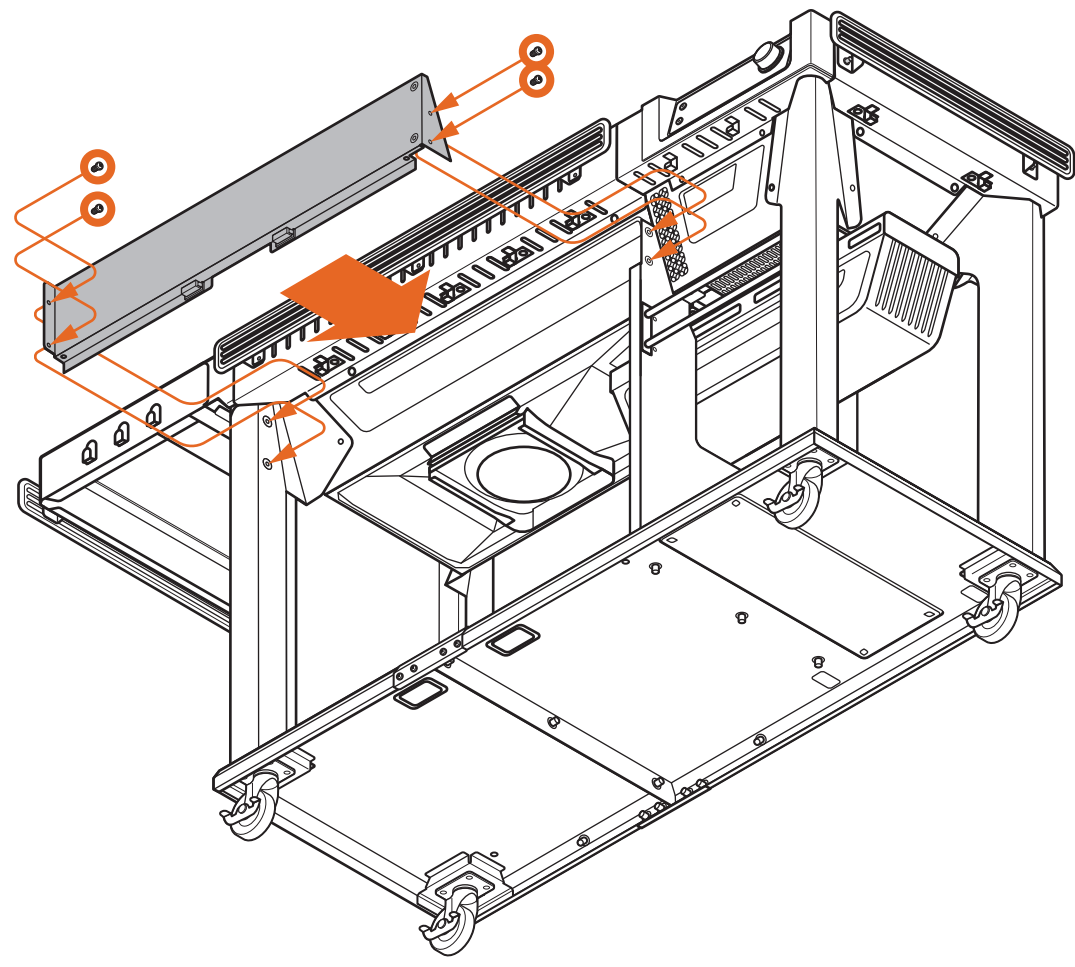
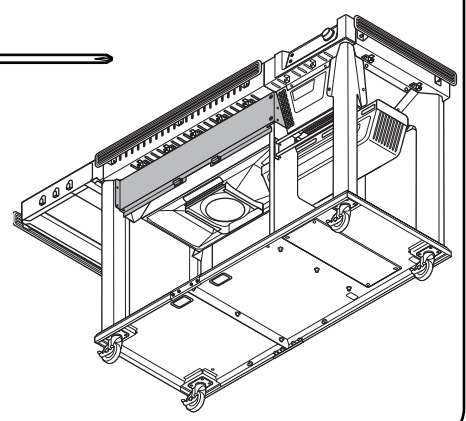

B



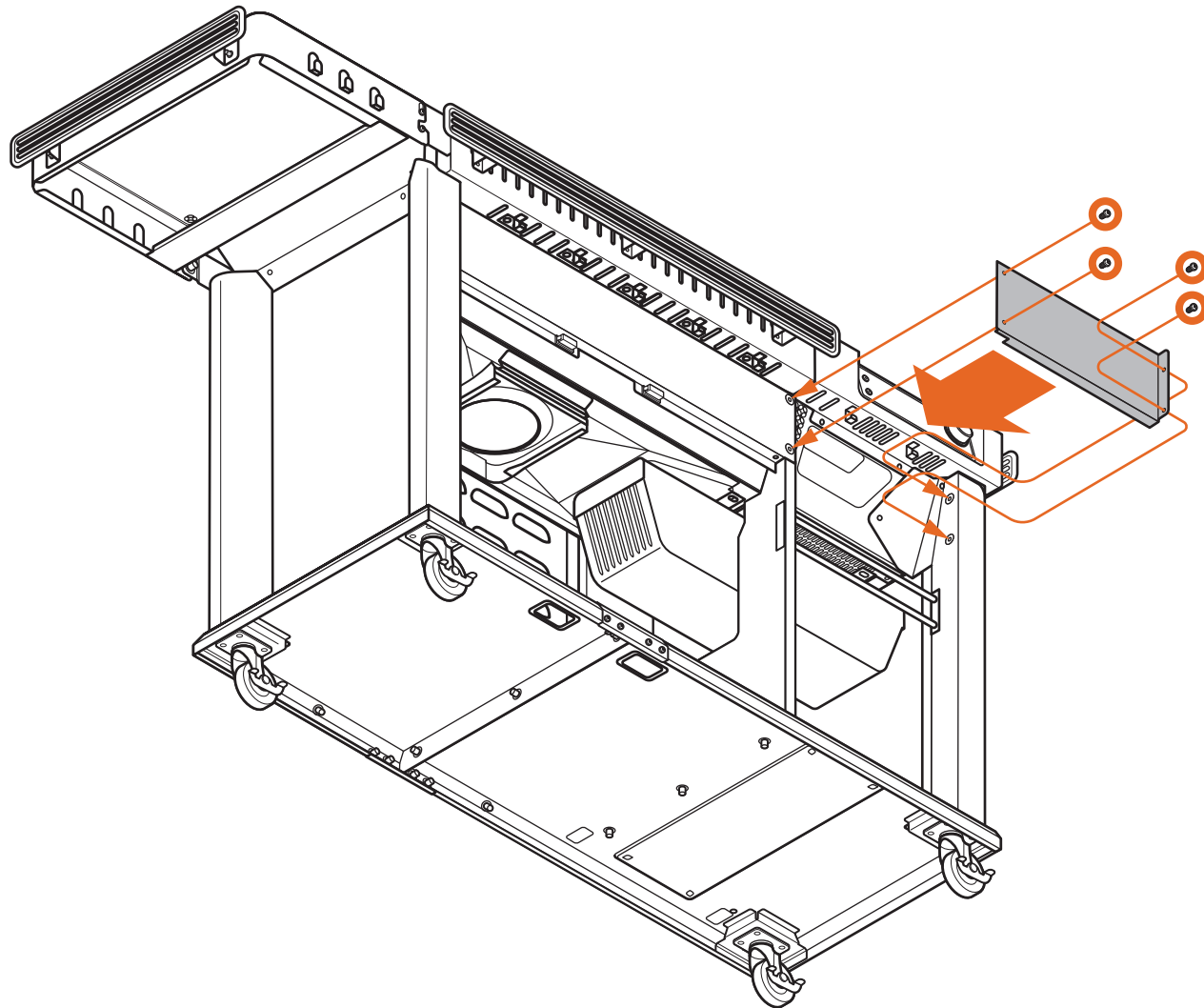
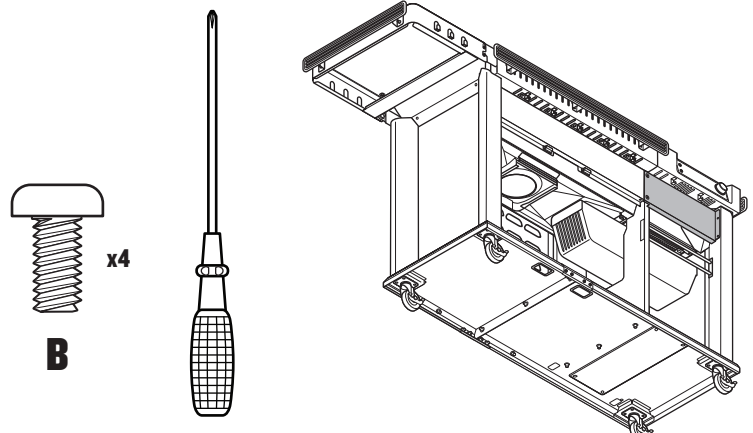

14 FIXER LA GARNITURE AVANT DROITE





15 FIXER LES PORTES

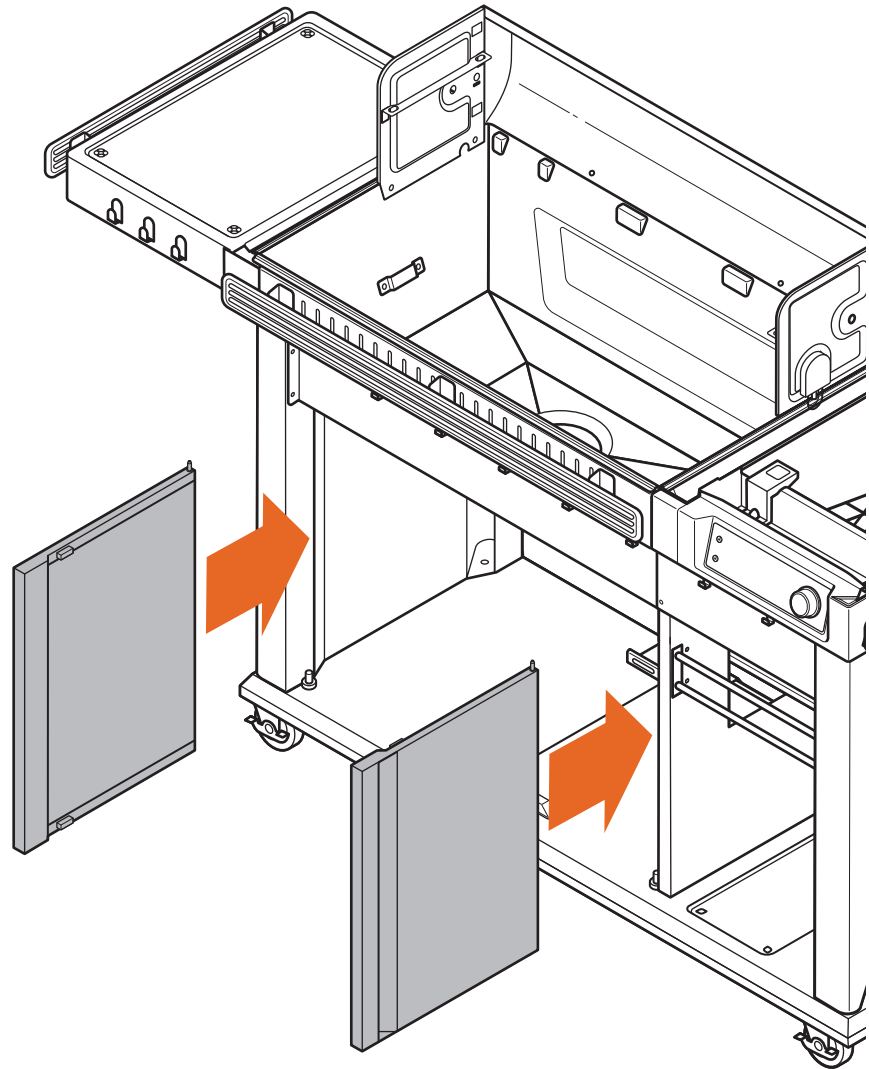
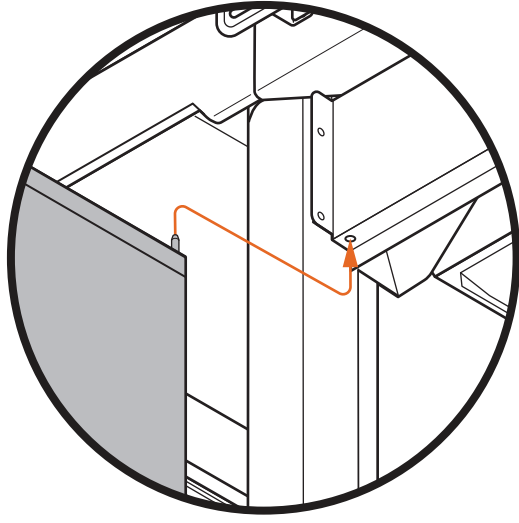
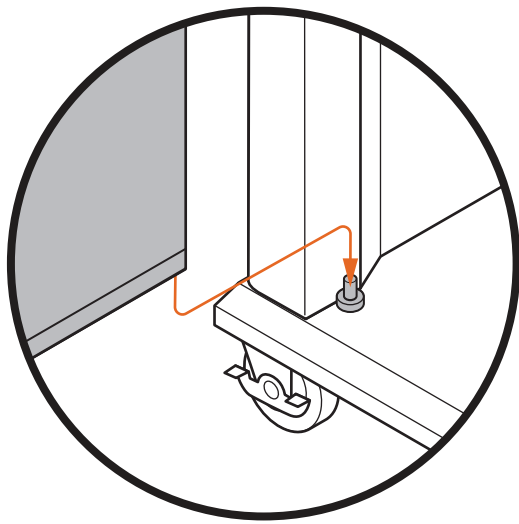
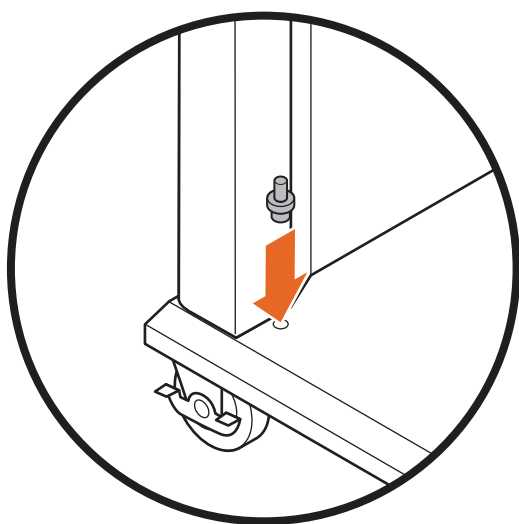
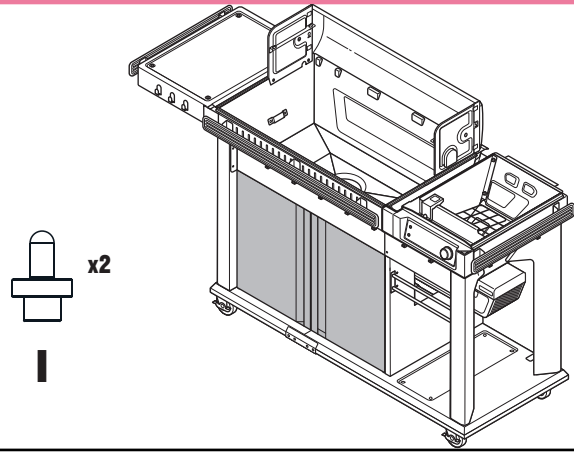



16 FIXER LA BANDE DE GARNITURE

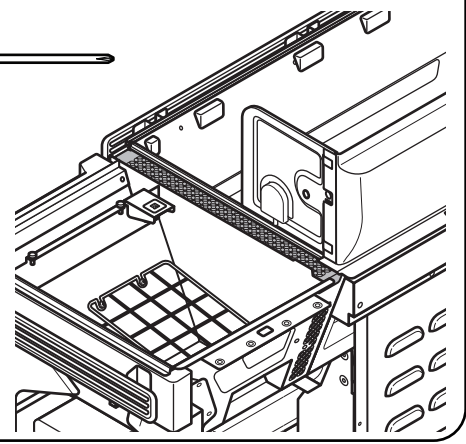
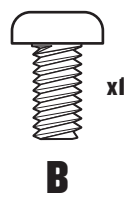
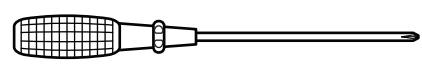

16A

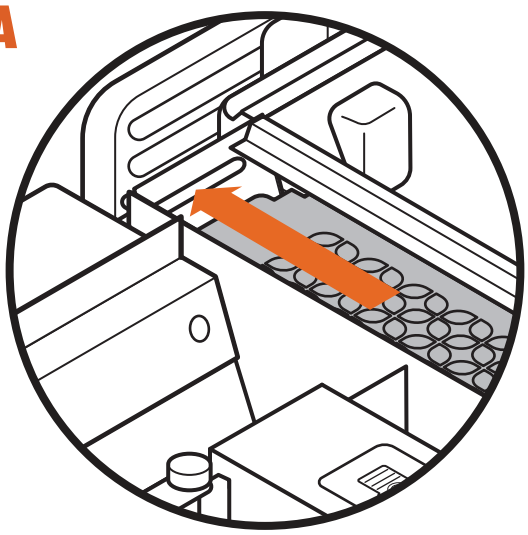

16B

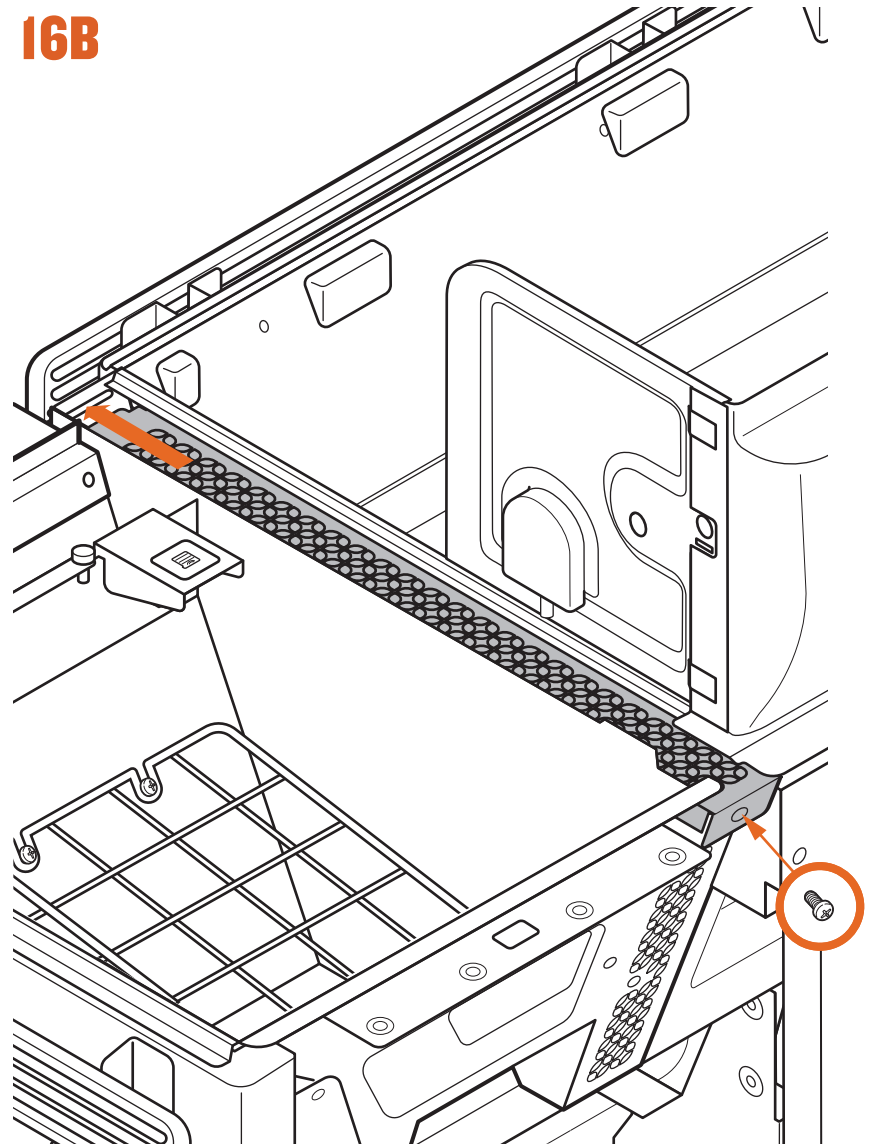

**BEAU TRAVAIL !
CHAPITRE 3 TERMINÉ !**

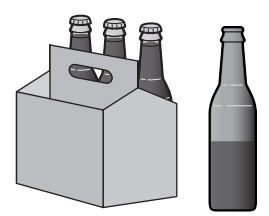

CHAPITRE 4

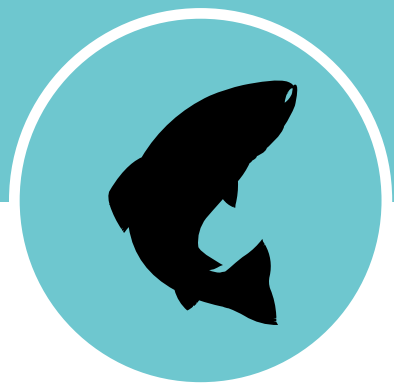
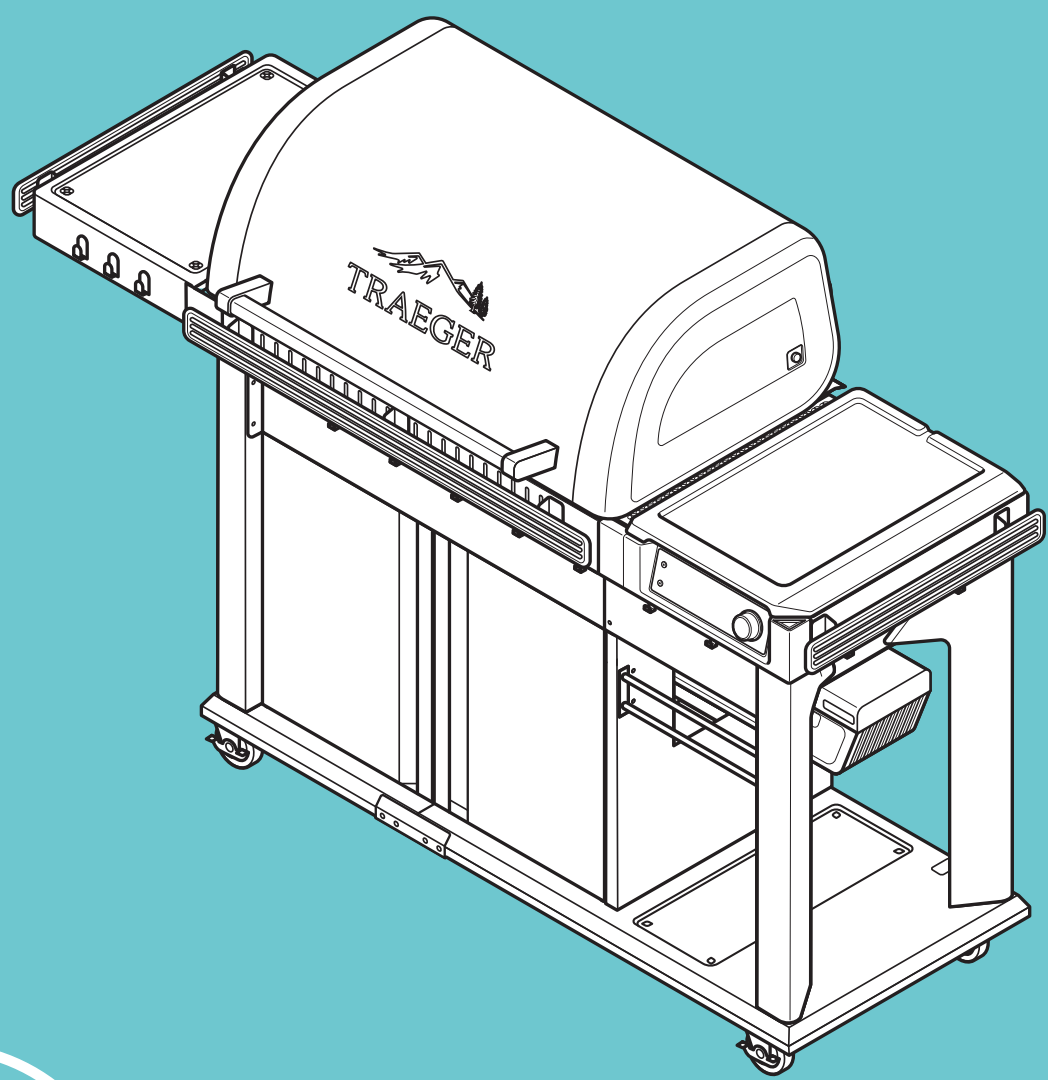

COUVERCLE ET COMPOSANTS INTERNES DU BARBECUE

CHAPITRE 4

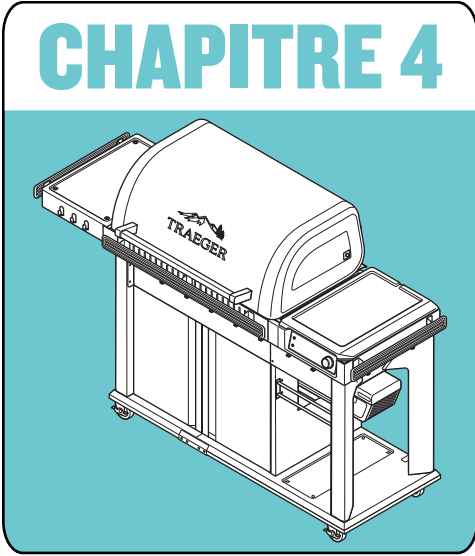

1 FIXER LE COUVERCLE DE LA TRÉMIE

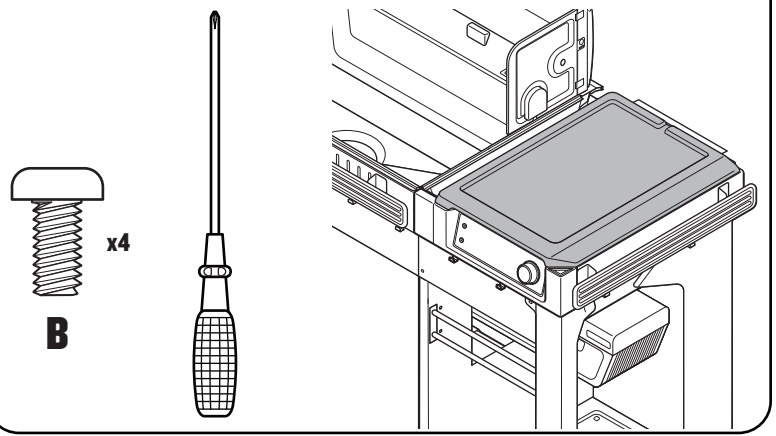

CONSEIL DE PRO : serrez d'abord toutes les vis à la main, puis terminez le serrage avec un tournevis.

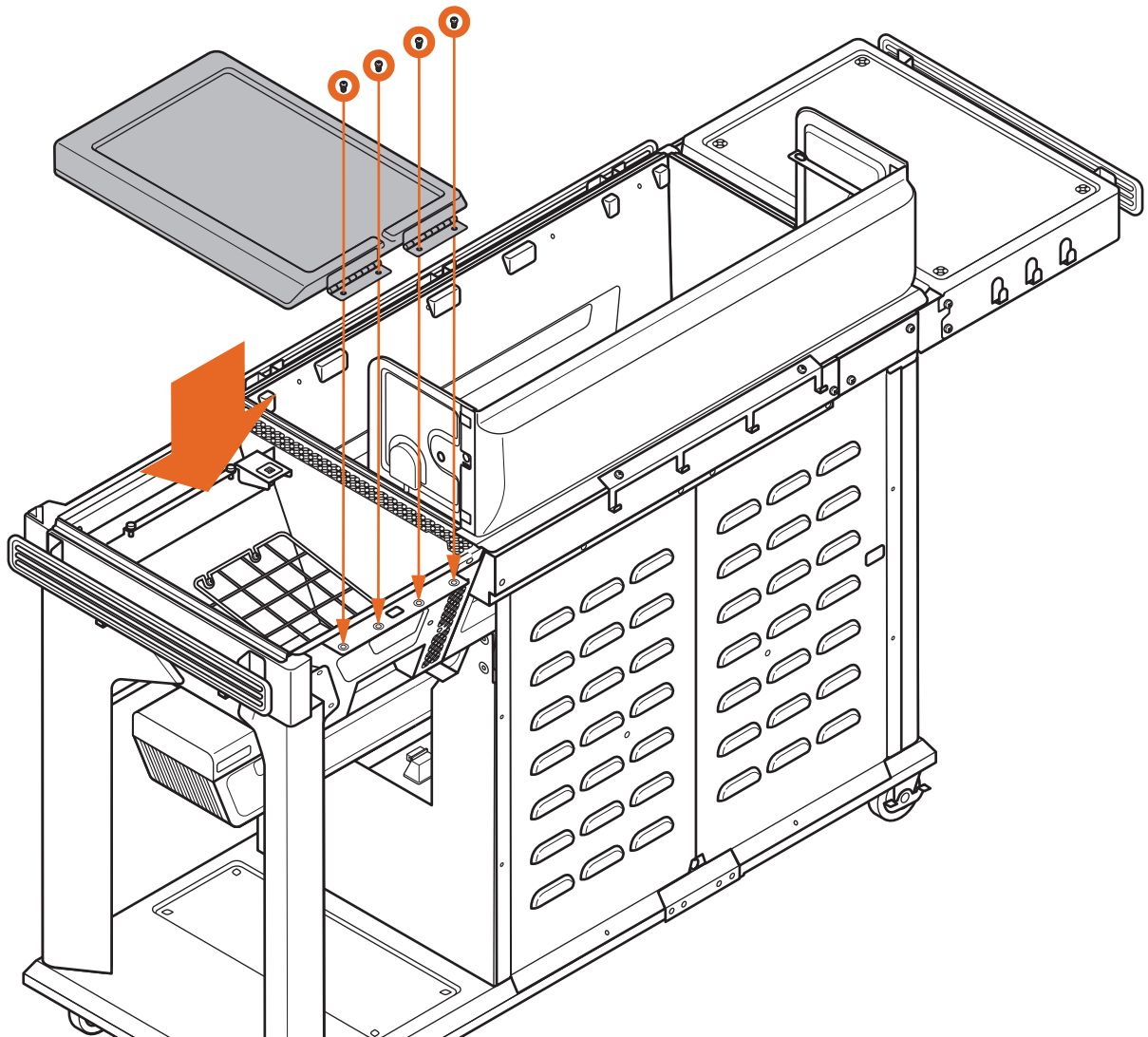



2 INSTALLER LA GOULOTTE, LE PARE-BRAISES ET LE DÉFLECTEUR

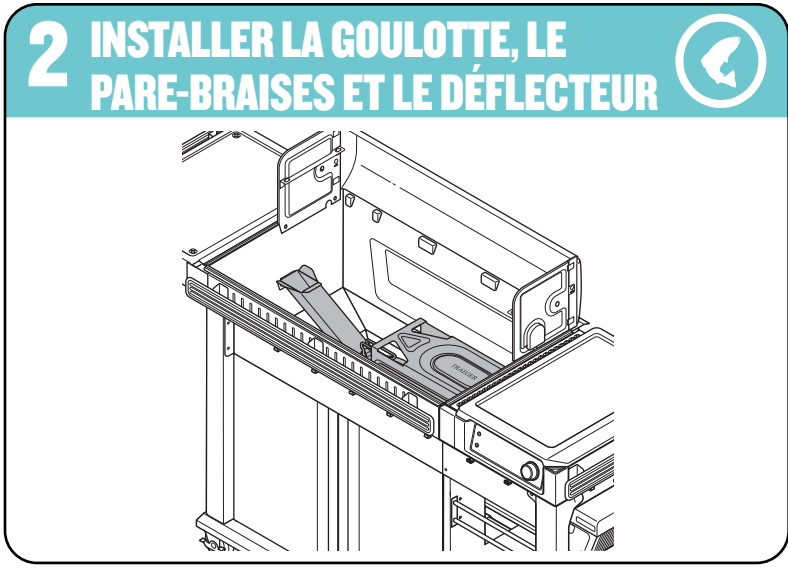
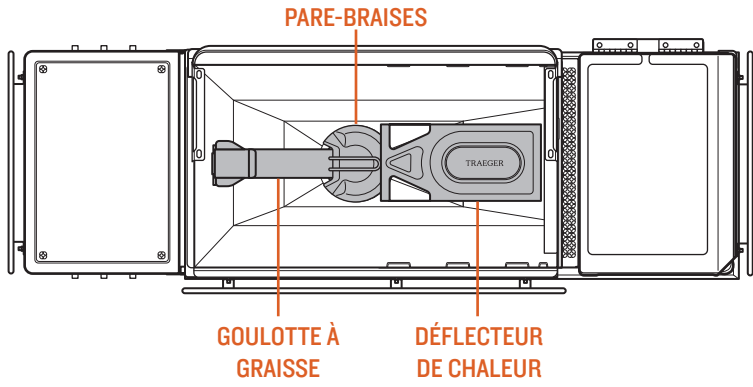

GOULOTTE À GRAISSE

PARE-BRAISES

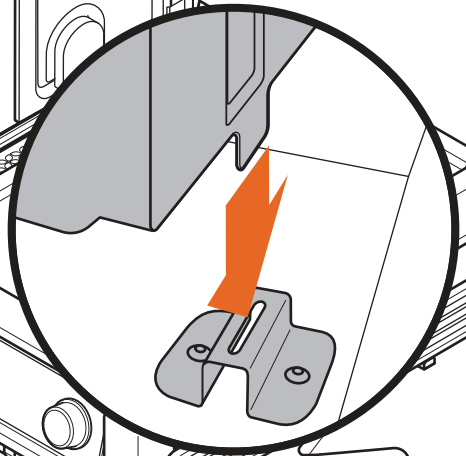
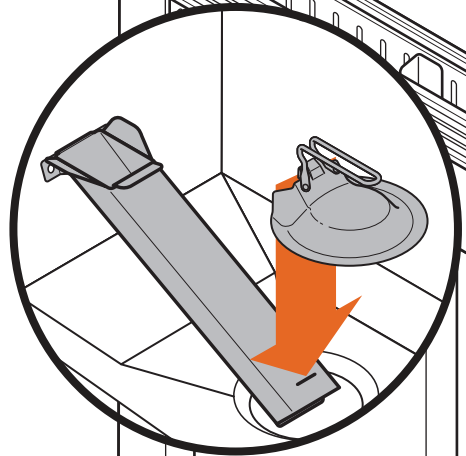
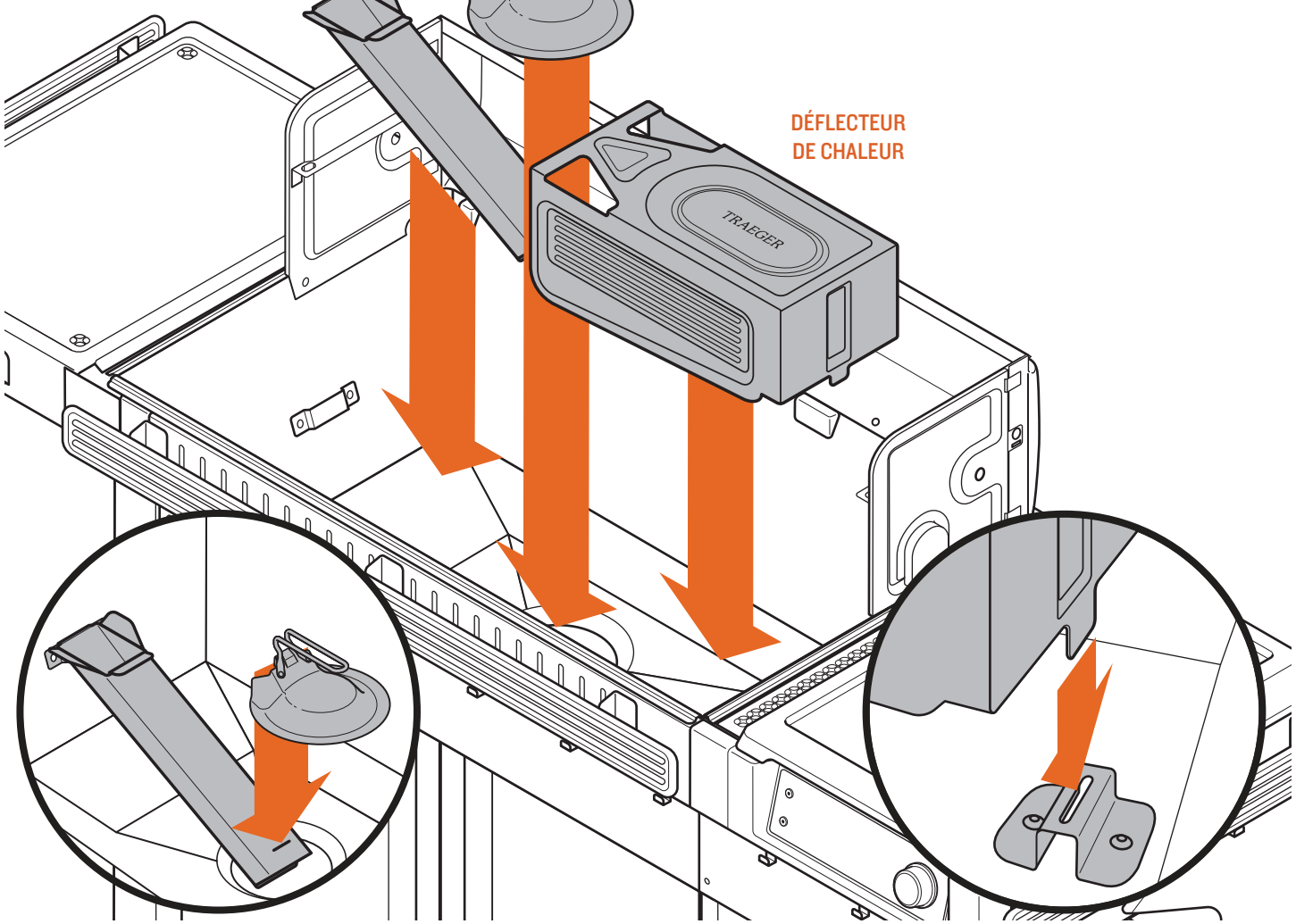



3 INSTALLER LE PLATEAU D'EGOUTTEMENT

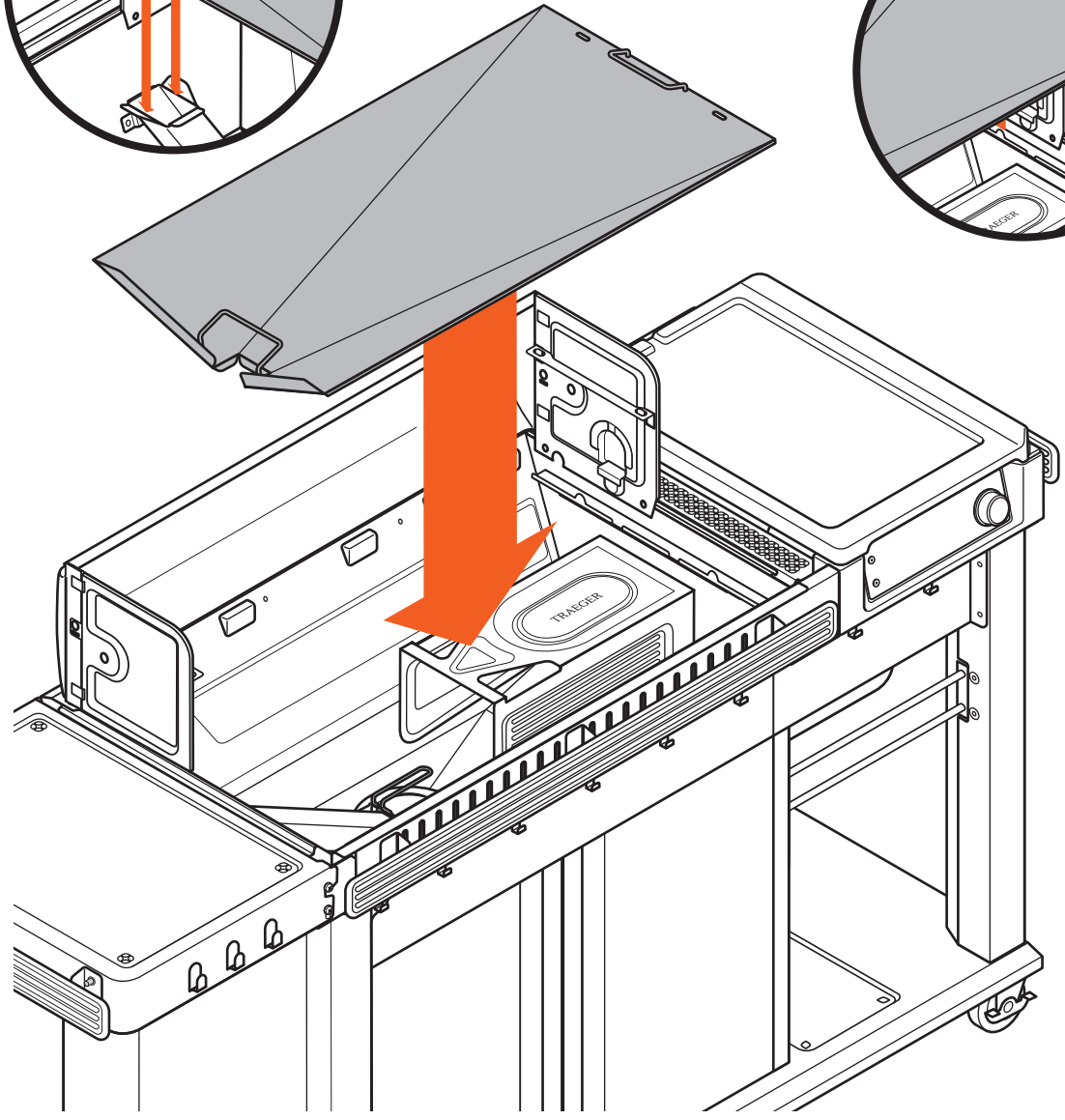
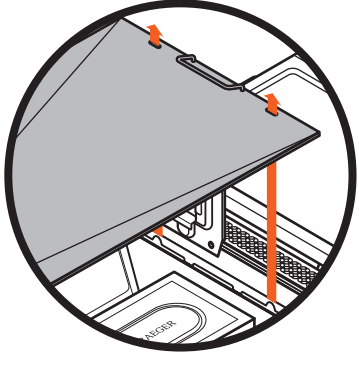
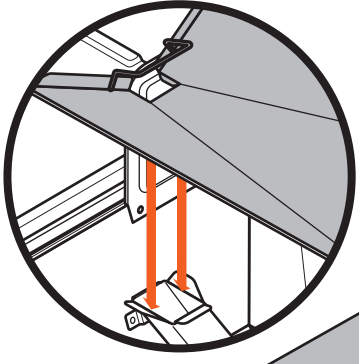
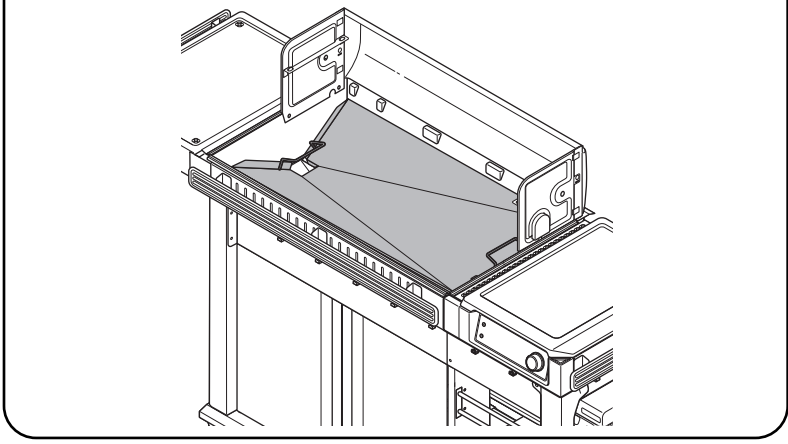



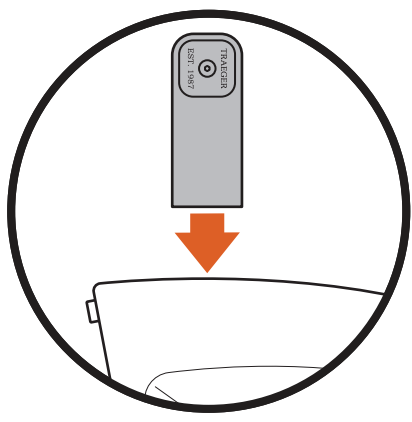
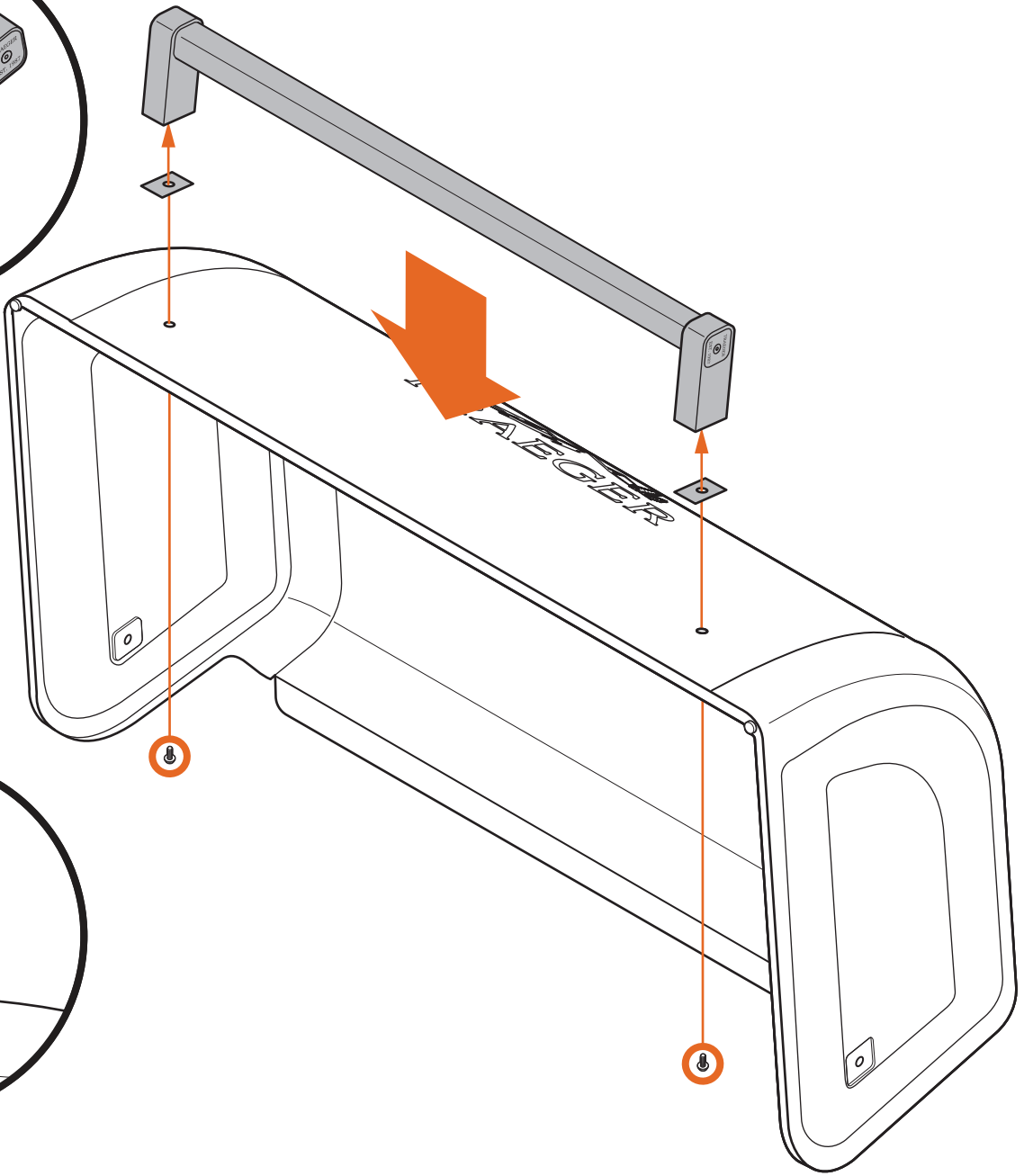
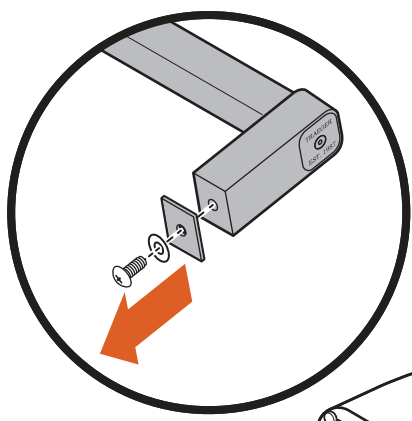
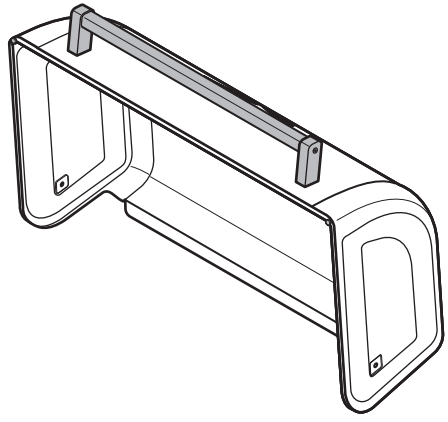
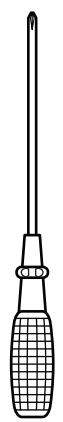

4A FIXER LA POIGNÉE DU COUVERCLE





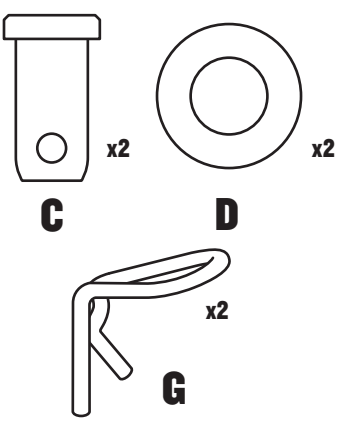
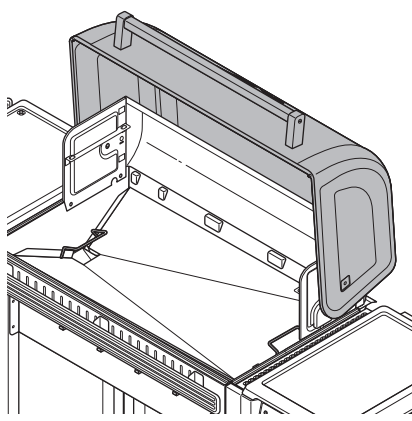

CONSEIL DE PRO : utilisez deux personnes pour fixer le couvercle.

4B FIXER LE COUVERCLE



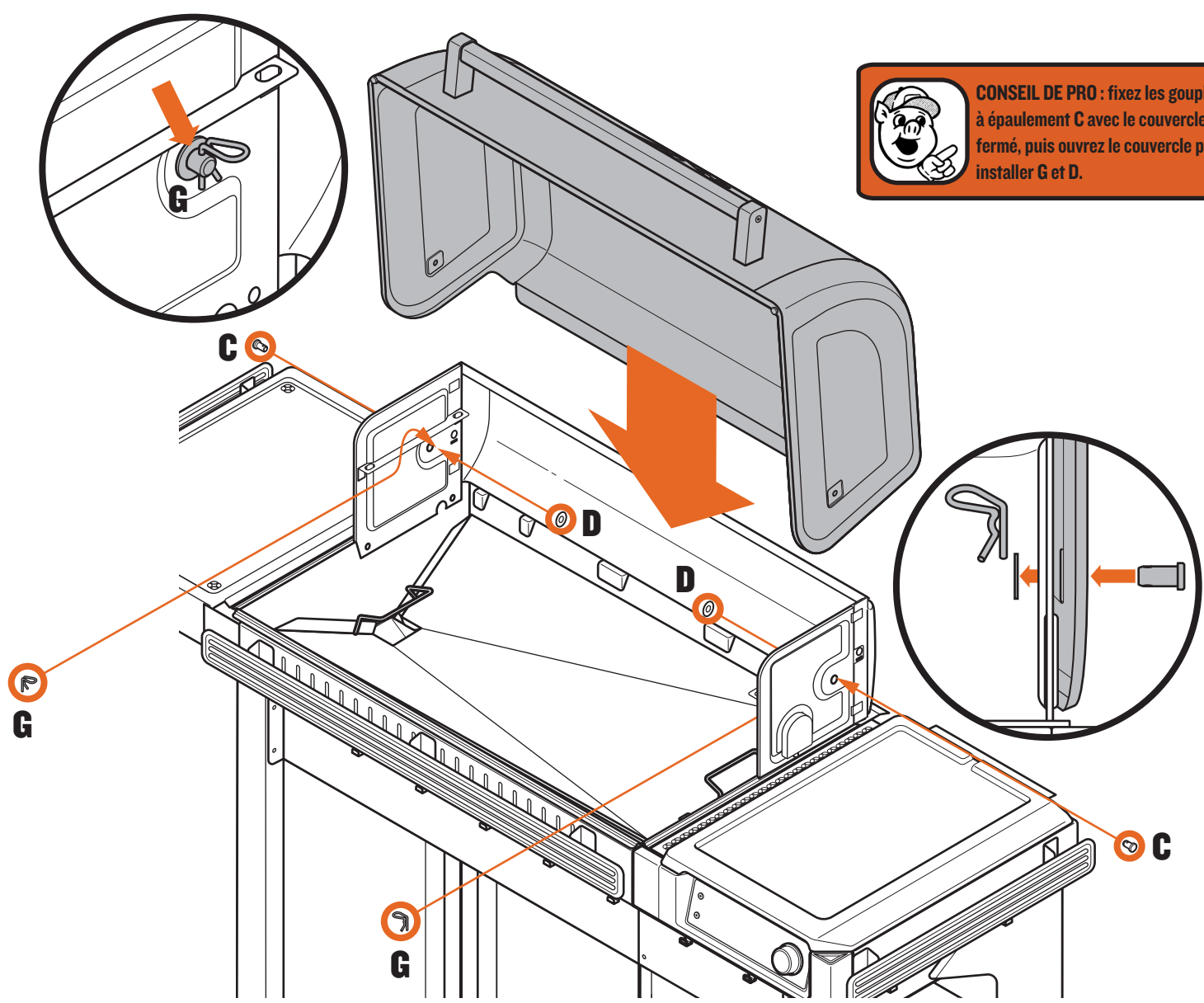

CONSEIL DE PRO : fixez les goupilles à épaulement C avec le couvercle fermé, puis ouvrez le couvercle pour installer G et D.



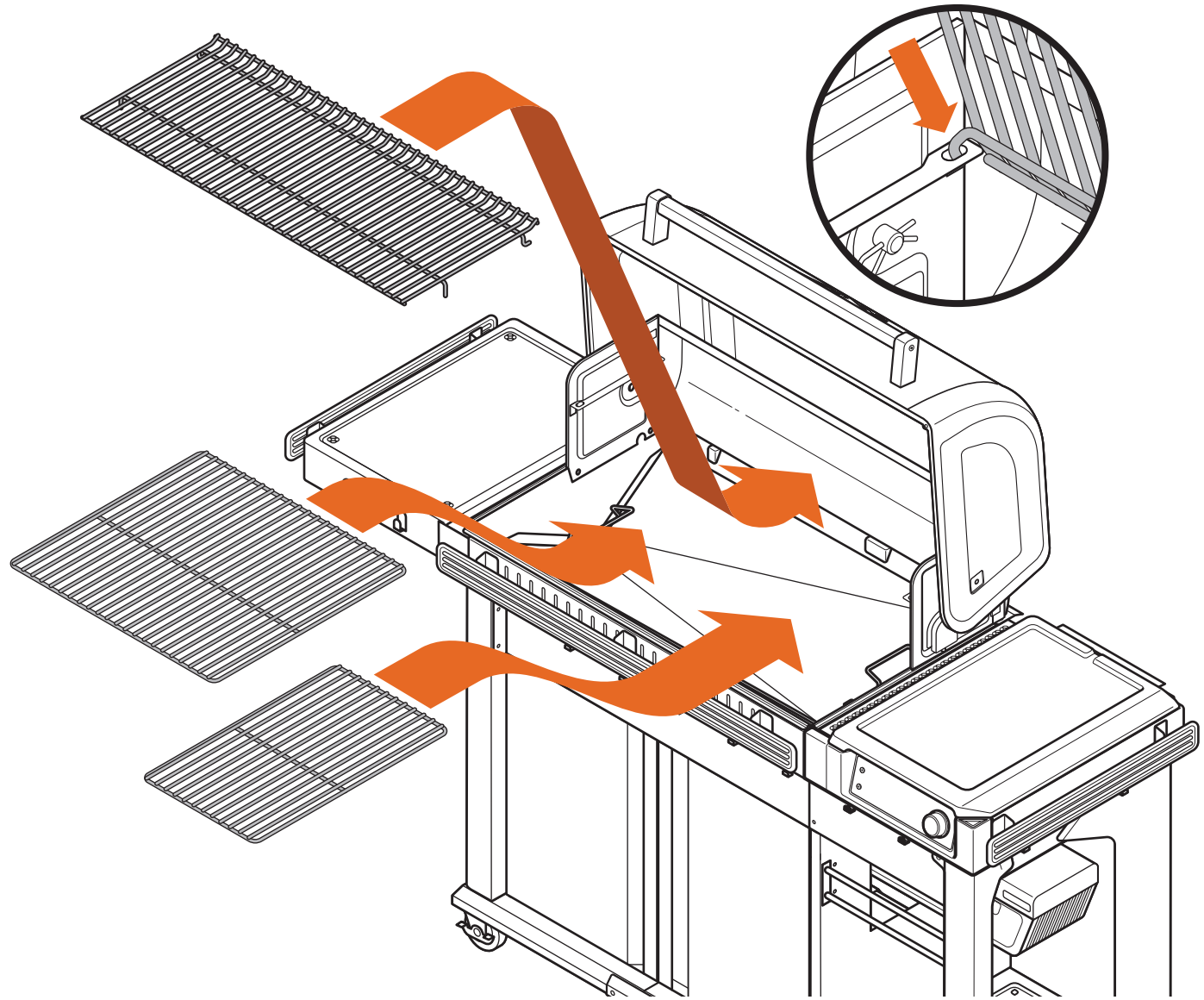
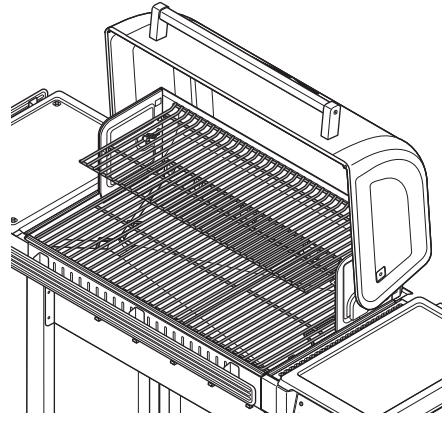

5 INSTALLER LES GRILLES





6 INSTALLER LE SEAU À GRAISSE ET À CENDRES

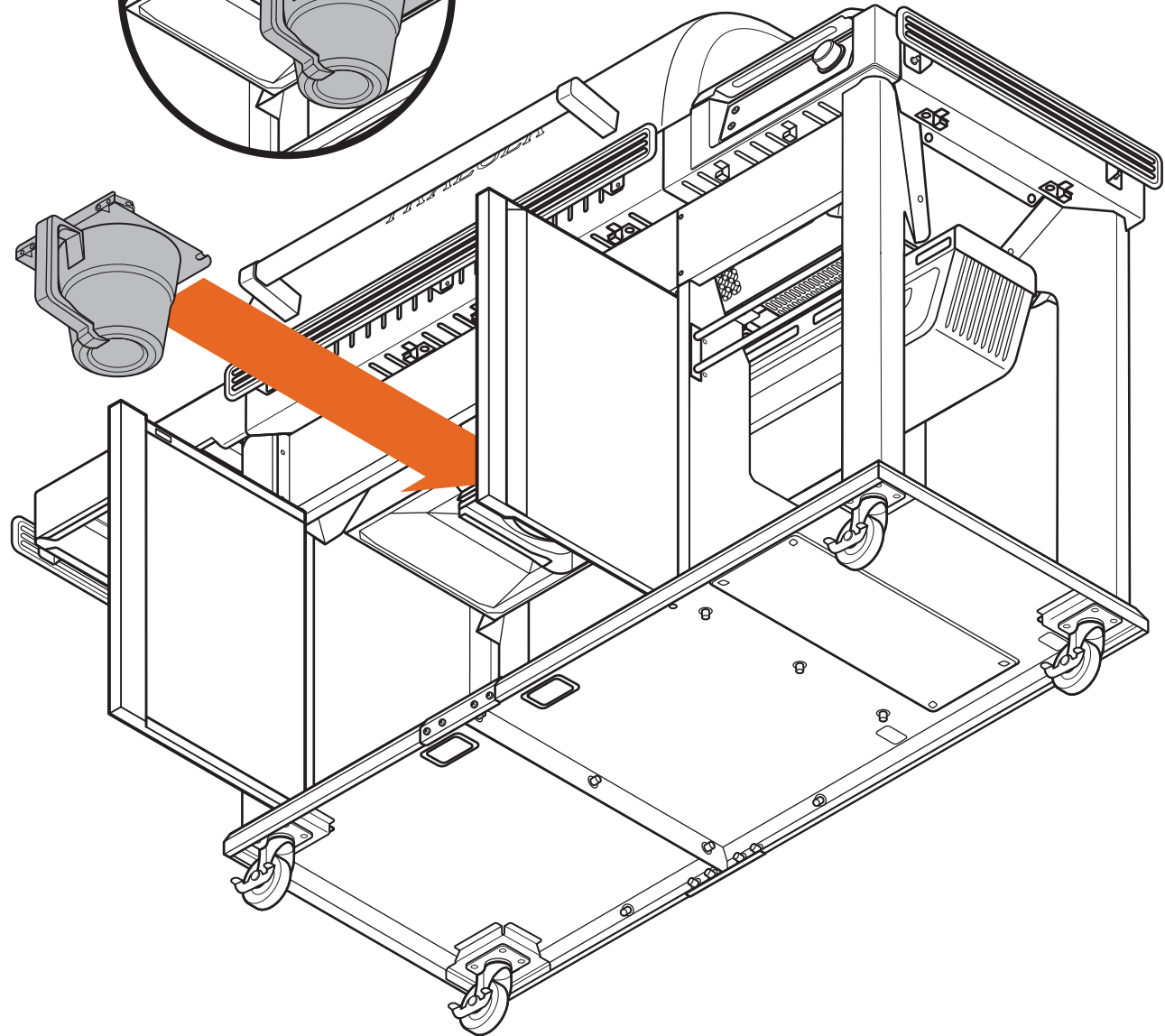
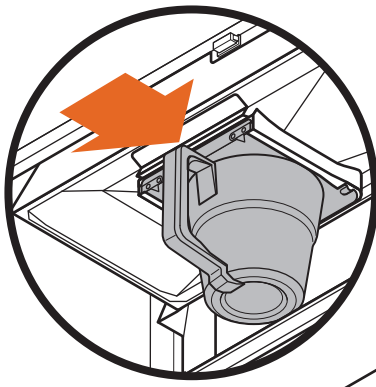
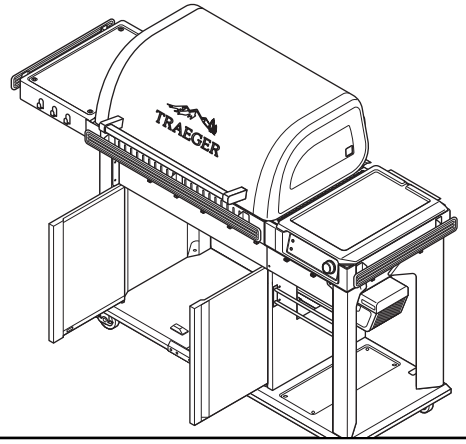



7 BRANCHER LE CORDON D'ALIMENTATION

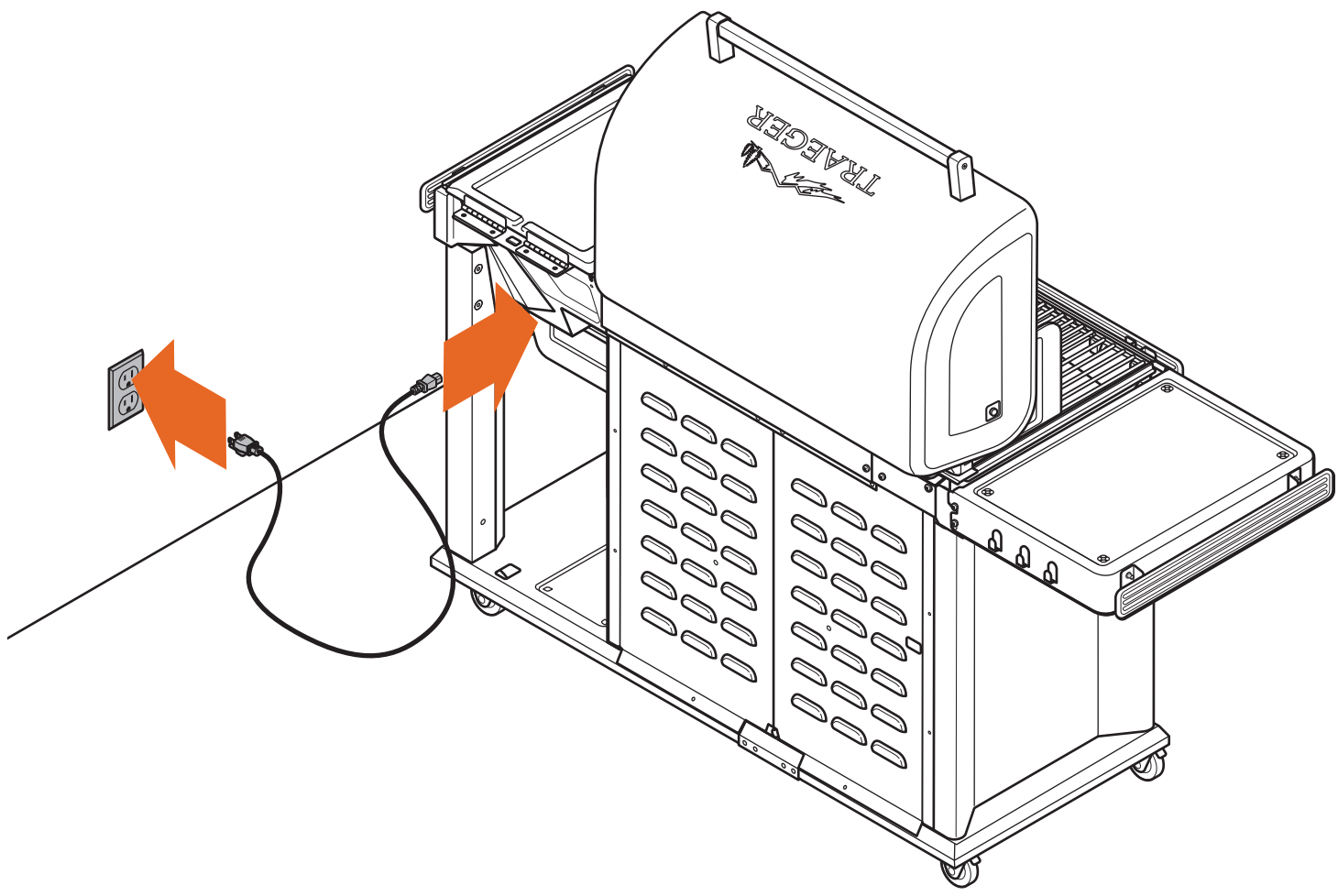
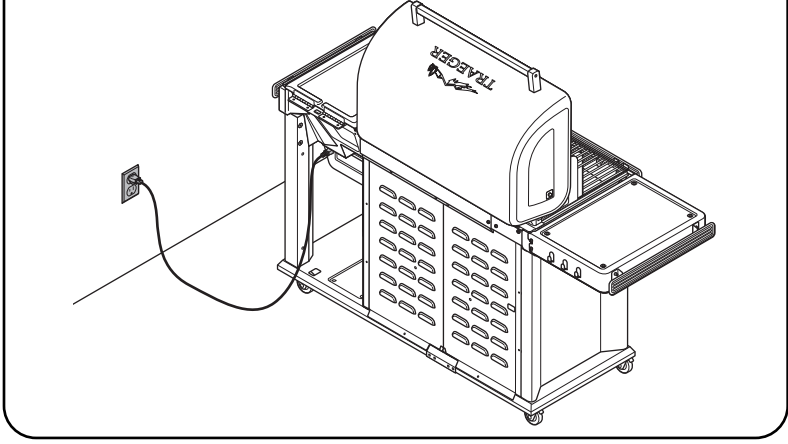

**BEAU TRAVAIL !
CHAPITRE 4 TERMINÉ !**

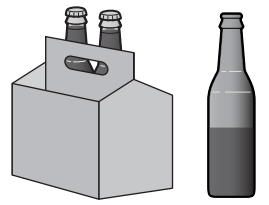

RANGEMENT DES PIÈCES ET ACCESSOIRES



AVERTISSEMENT ! NE PLACEZ PAS DE HOUSSE DE BARBECUE OU QUOI QUE CE SOIT D'INFLAMMABLE DANS L'ESPACE DE RANGEMENT SOUS LE BARBECUE.

Sonde filaire et cordon d'alimentation

À RANGER (APRÈS CHAQUE CUISSON) :

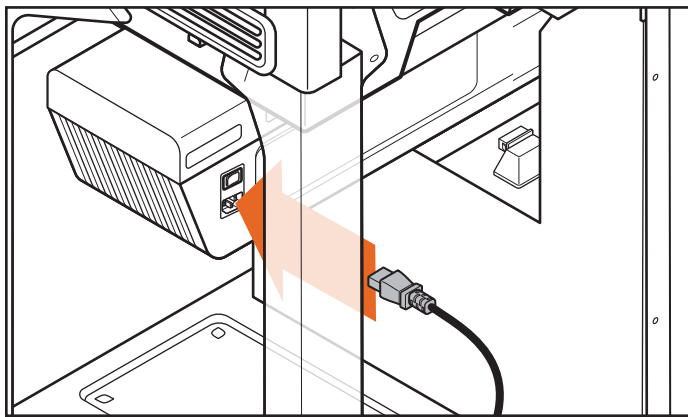
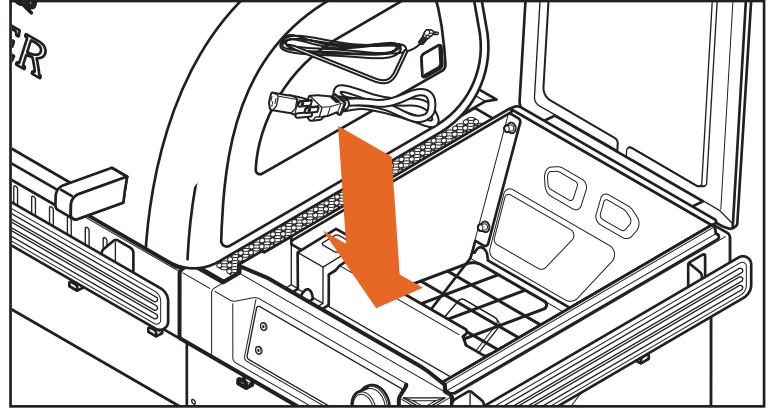
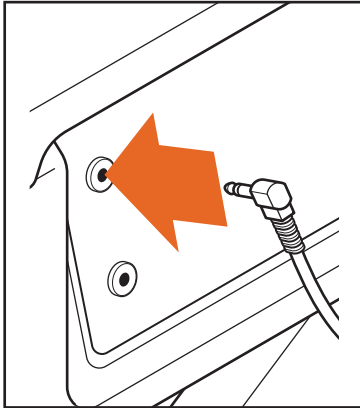

Grilles de barbecue, plateau d'égouttement, goutte à graisse et pare-braises

POUR RANGER PENDANT LE NETTOYAGE :

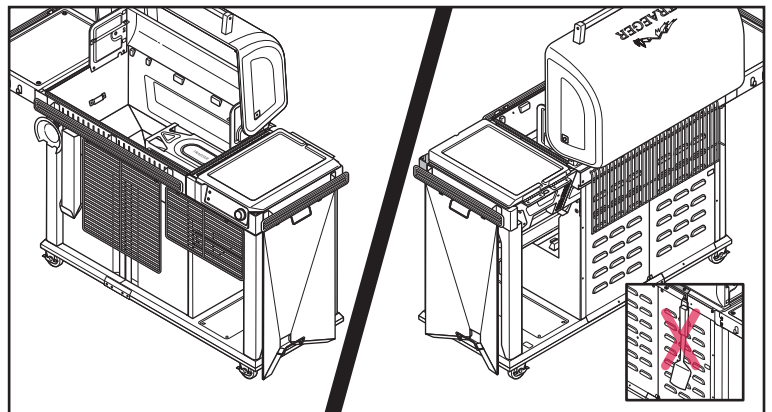
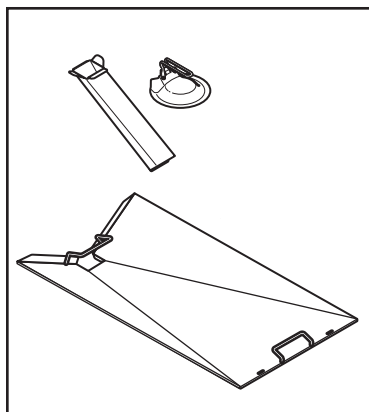
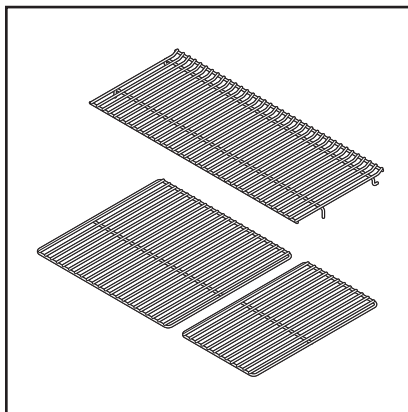

CONSEIL DE PRO : Ne suspendez pas et ne rangez pas les ustensiles de cuisines sur les crochets de la grille. Cela pourrait endommager les ustensiles.

RANGEMENT DES PIÈCES ET ACCESSOIRES SUITE

Trémie

Si vous n'utilisez pas votre barbecue Traeger Woodridge pendant une période prolongée, videz les granules de la trémie.

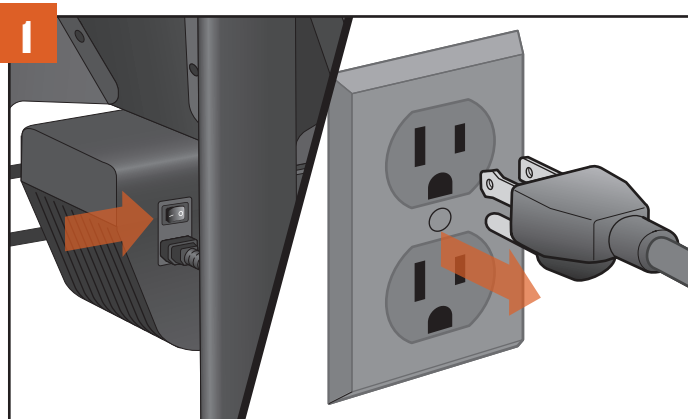

Mettez l'interrupteur principal en position **ARRÊT (0)** et débranchez le cordon d'alimentation. Si le barbecue est encore chaud, laissez-le refroidir complètement.

REMARQUE : l'aspect de la prise peut varier selon la région.

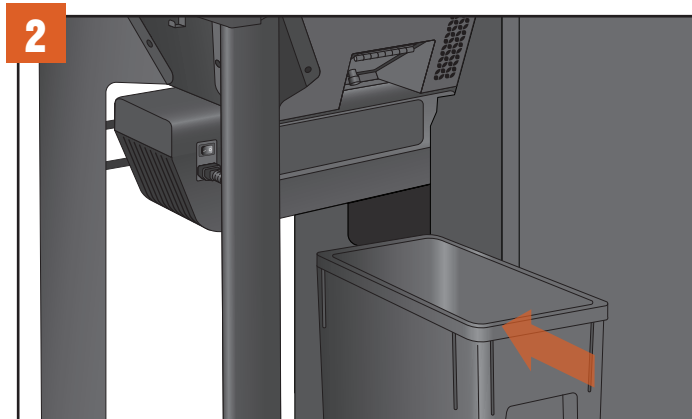

Avant de vider la trémie, assurez-vous que le bac à granules Traeger StayDry (vendu séparément) est placé directement sous la porte d'évacuation des granules.

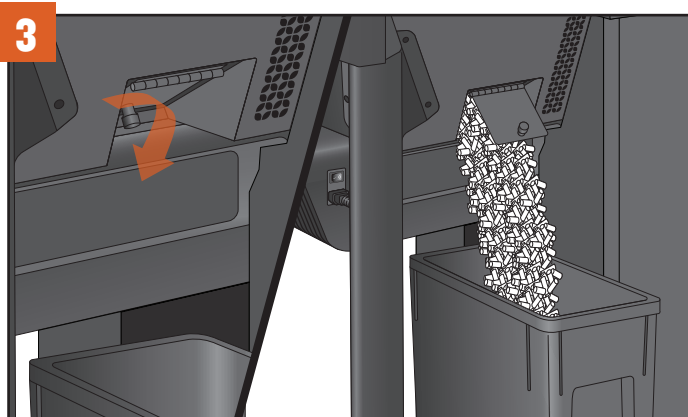

Dévissez le bouton situé à l'arrière du boîtier de la vis sans fin et ouvrez la porte d'évacuation des granules. Les granules se videront dans le bac à granules StayDry. Aspirez toute la sciure restante de la trémie et de la vis sans fin.



AVERTISSEMENT ! NE VIDEZ PAS LA TRÉMIE TANT QUE LE BARBECUE N'EST PAS COMPLÈTEMENT REFROIDI ET QUE L'ALIMENTATION ELECTRIQUE N'EST PAS COUPÉE ; SINON, LES GRANULES PEUVENT ÊTRE TRÈS CHAUDS.



AVERTISSEMENT ! NE PLACEZ PAS VOTRE MAIN DANS LA TRÉMIE AU-DELÀ DE LA GRILLE DE SÉCURITÉ.

CONNEXION DE VOTRE BARBECUE

Notre engagement à fournir des produits et des expériences de classe mondiale signifie que nous travaillons constamment à améliorer les performances et les fonctionnalités du barbecue. Nous vous recommandons vivement de connecter votre barbecue Traeger Woodridge à WiFIRE en suivant les instructions ci-dessous. Lorsque votre barbecue est connecté et allumé, les mises à jour sont automatiquement téléchargées, ce qui garantit que votre barbecue fonctionne toujours à des performances optimales.

IMPORTANT :

- Assurez-vous que votre appareil intelligent fonctionne avec la dernière version du système d'exploitation et que le Bluetooth est activé.
- Si vous utilisez un appareil Android, activez les services de localisation.
- Pour connecter votre barbecue à votre Wi-Fi domestique, votre barbecue doit être sous tension. Assurez-vous que l'interrupteur d'alimentation principal est en position **MARCHE (I)** et allumé.
- Le signal du routeur de votre Wi-Fi domestique doit être de 2,4 GHz (un routeur double bande devrait également fonctionner). La bande 2,4 GHz est actuellement la norme industrielle pour les appareils connectés. Elle a une meilleure portée et pénètre mieux les murs/plafonds/obstacles que celle de 5 GHz, que votre barbecue ne peut pas reconnaître.

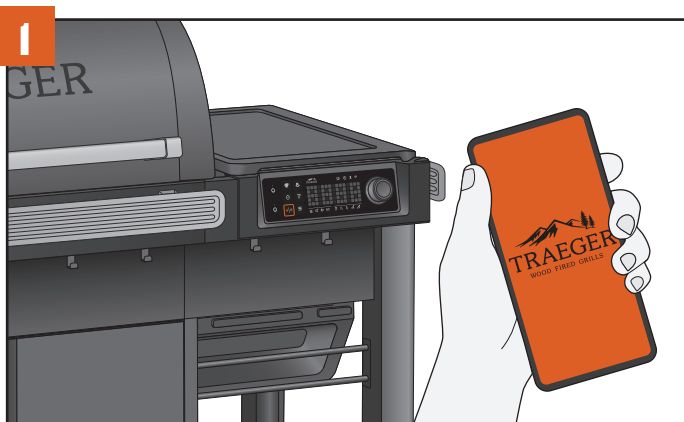
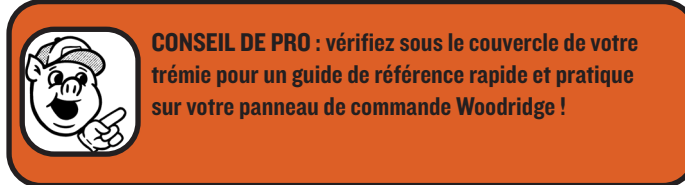
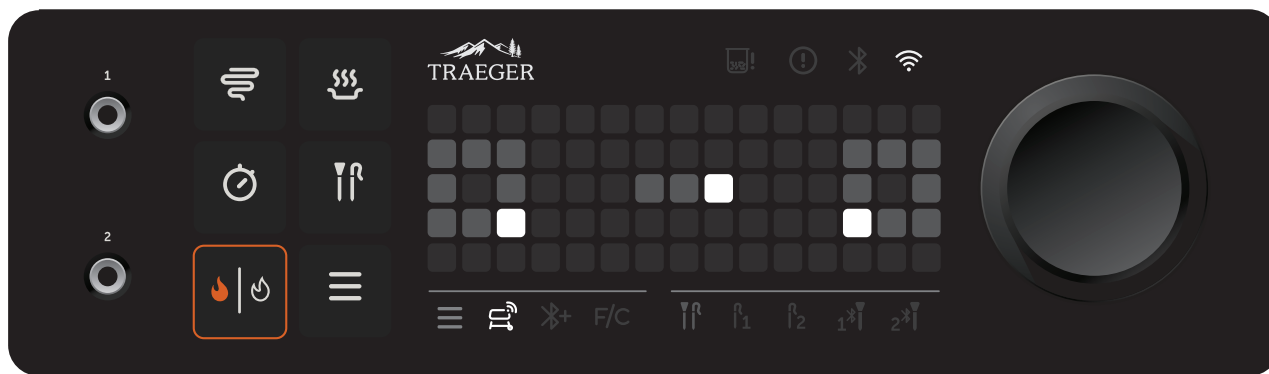

1
Allez sur l'App Store d'Apple ou sur le Google Play Store d'Android pour télécharger la dernière version de l'appli Traeger.

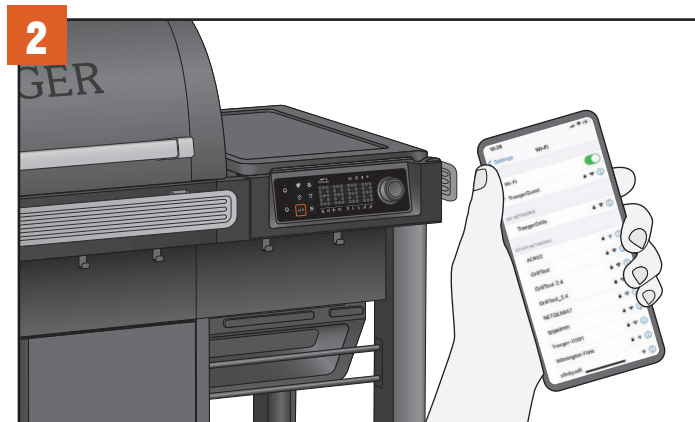

2
Assurez-vous que votre appareil intelligent est connecté au réseau Wi-Fi auquel vous voulez connecter votre barbecue. Le signal du routeur doit être de 2,4 GHz, car le barbecue n'est pas compatible avec 5 GHz.

CONNEXION DE VOTRE BARBECUE SUITE

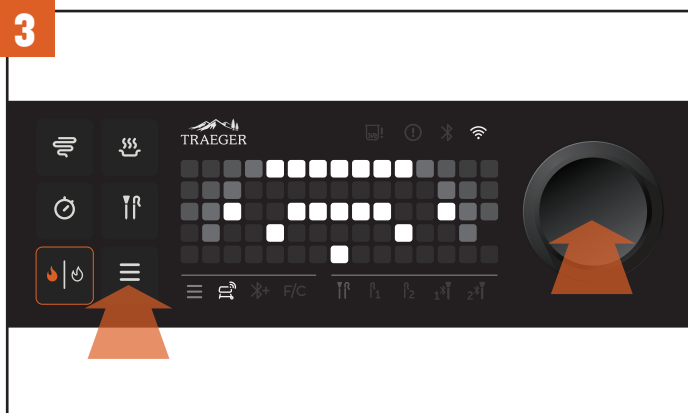

Après avoir allumé votre barbecue, appuyez sur le bouton de menu. Vous verrez l'icône Wi-Fi du barbecue s'allumer dans la barre de menu sous la matrice de points, et une animation d'un signal Wi-Fi avec un point d'interrogation s'affichera. Appuyez sur la molette de sélection pour sélectionner cette option et commencer le processus de connexion.

REMARQUE : vous pouvez parcourir les options du menu en tournant la molette de sélection après avoir appuyé sur le bouton de menu. Lorsque vous tournez la molette, les icônes de la barre de menu situées sous l'écran à matrice de points s'allument pour indiquer votre sélection.

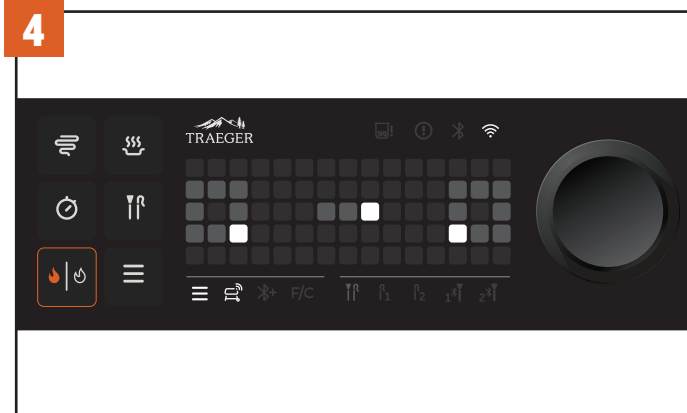

Après avoir sélectionné WiFIRE, l'animation d'appariement ci-dessus s'affichera à l'écran, indiquant que votre barbecue diffuse son signal Bluetooth et est prêt à être apparié. Ouvrez votre appareil intelligent sur l'appli Traeger et connectez-vous à votre compte. Sur l'écran d'accueil de l'appli Traeger, appuyez sur l'icône du barbecue en bas au centre de l'écran pour lancer la connexion.

Suivez les instructions de l'appli Traeger pour (1) appairier votre téléphone à votre barbecue (via une connexion Bluetooth temporaire), (2) connecter votre barbecue à votre réseau Wi-Fi domestique de 2,4 GHz souhaité et (3) terminer le processus de configuration du barbecue.

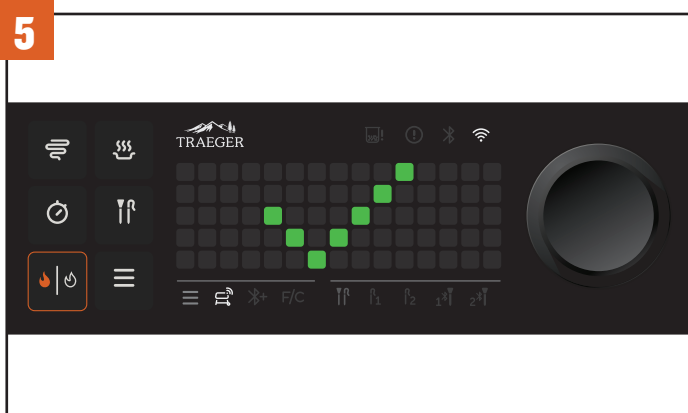

Une coche verte s'affichera sur votre panneau de commande pour indiquer que vous vous êtes connecté avec succès à WiFIRE. L'icône Wi-Fi en haut à droite au-dessus de l'écran à matrice restera allumée lorsque le barbecue est connecté.

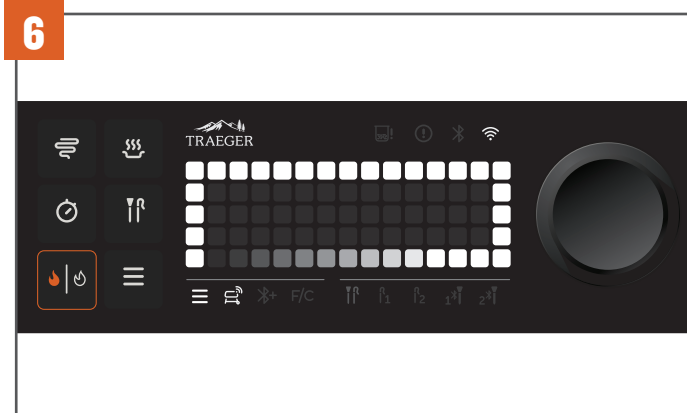

Une fois connecté à WiFIRE, vous pourriez voir cette animation sur votre écran. N'éteignez pas votre barbecue tant que vous ne voyez pas une coche verte. Cela signifie que votre barbecue télécharge et applique une mise à jour. Tout comme votre smartphone, ces mises à jour permettent à votre barbecue de fonctionner correctement, en toute sécurité et à des performances optimales. Une fois la mise à jour terminée, vous verrez une coche verte et le barbecue reviendra en mode veille – cuisinons !

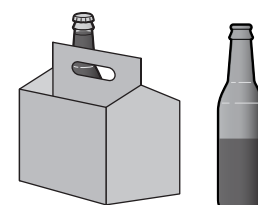

CULOTTAGE DE VOTRE BARBECUE



CONSEIL DE PRO : le culottage doit être effectué avant de cuisiner des aliments sur votre barbecue. Pour plus d'informations, scannez ici pour accéder au Guide de culottage.

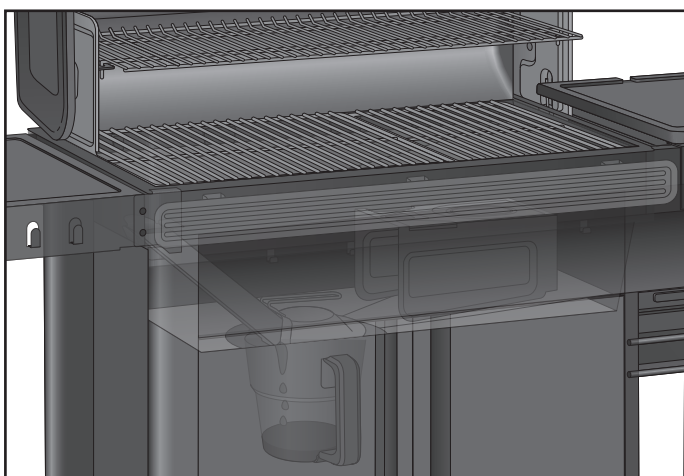

IMPORTANT :

- Assurez-vous que tous les composants sont correctement installés dans le barbecue et que tous les matériaux d'emballage/d'expédition sont retirés avant le culottage.
- N'essuyez pas le film de graisse protecteur sur les composants avant le culottage. Ce film offre une couche protectrice plus durable.

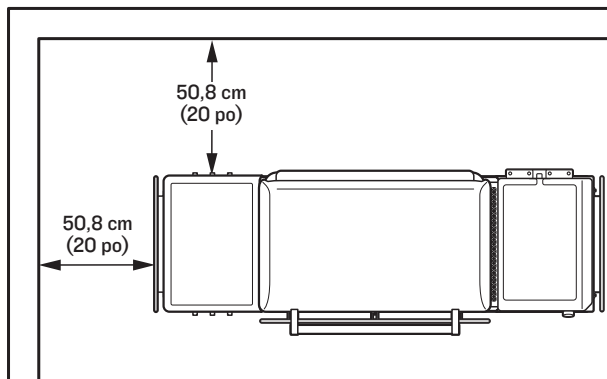

⚠ AVERTISSEMENT Risque d'incendie

- Lorsque le barbecue Traeger est utilisé, il faut maintenir une distance **MINIMUM** de 50,8 cm (20 po) entre le barbecue et tout autre matériau combustible à proximité, y compris les rampes en bois, le revêtement de la maison, les cadres de fenêtres, les meubles, les arbres, les poubelles, etc.

Avant de pouvoir cuisiner sur votre barbecue, celui-ci doit être culotté. Il s'agit d'un processus sans intervention manuelle dans lequel le barbecue vide est chauffé à une température très élevée. Ce cycle de culottage garantit que le barbecue est nettoyé de tout résidu d'usine, préparé et prêt pour des performances optimales.

⚠ DANGER Risque lié au monoxyde de carbone

La combustion de granules à bois génère du monoxyde de carbone qui peut entraîner des maladies, des blessures graves, voire la mort. Respectez ces directives pour éviter que ce gaz sans couleur ni odeur ne vous intoxique vous et votre famille, vos animaux de compagnie ou autres :

- N'utilisez votre barbecue Traeger qu'à l'extérieur, dans un endroit bien ventilé. Ce barbecue est conçu **UNIQUEMENT POUR UN USAGE EN EXTÉRIEUR**.
- N'utilisez **jamais** le barbecue Traeger dans un endroit clos ou sans aération adéquate.
- Il faut connaître les symptômes d'une intoxication au monoxyde de carbone : maux de tête, étourdissements, faiblesse, nausées, vomissements, somnolence et confusion. Le monoxyde de carbone réduit la capacité du sang à transporter l'oxygène. De faibles niveaux d'oxygène dans le sang entraînent une perte de conscience et la mort.
- Consultez un médecin si vous ou quelqu'un d'autre présente des symptômes de type rhume ou grippe lorsque vous cuisinez ou que vous êtes à proximité de cet appareil. Une intoxication au monoxyde de carbone, facilement confondue avec un rhume ou une grippe, est souvent détectée trop tard.
- La consommation d'alcool ou de médicaments augmente les effets de l'intoxication au monoxyde de carbone.
- Le monoxyde de carbone est particulièrement toxique pour les mères et leur bébé pendant la grossesse, pour les nouveau-nés, les personnes âgées, les fumeurs, et les personnes présentant des problèmes du sang ou de circulation sanguine, comme l'anémie ou les affections cardiaques.

⚠ AVERTISSEMENT Risque d'incendie

- N'utilisez **jamais** d'essence, de combustible de lanterne de type essence, de kérosène, de l'essence pour briquet, ou d'autres matériaux inflammables pour allumer ou « raviver » un feu.
- N'utilisez ou ne stockez **jamais** de liquides ou d'autres matériaux inflammables à proximité du barbecue.

⚠ AVERTISSEMENT Risque de brûlures

Les cendres doivent toujours être complètement refroidies avant d'être manipulées. Les cendres doivent être placées dans un récipient en métal avec un couvercle hermétique. Le récipient à cendres fermé doit être placé sur une surface non combustible ou par terre, à distance de tout matériau combustible, avant l'élimination finale. Les cendres doivent être conservées dans le récipient fermé jusqu'à leur élimination.

⚠ AVERTISSEMENT N'utilisez pas de granules de combustible

N'utilisez jamais de granules de combustible dans le barbecue, car ils peuvent contenir des contaminants et des additifs dangereux et endommager le barbecue.

CULOTTAGE DE VOTRE BARBECUE SUITE

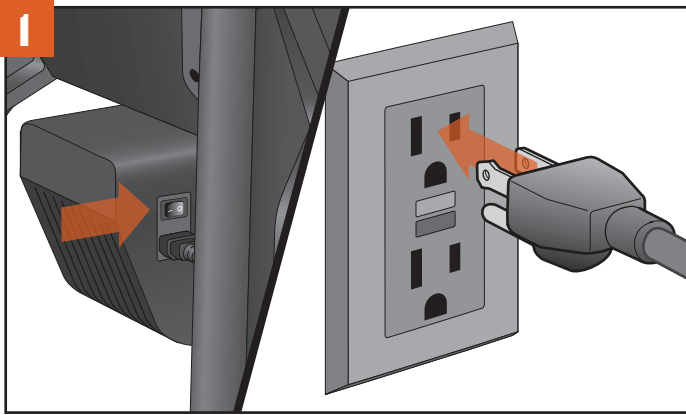

Avec l'interrupteur d'alimentation principal en position ARRÊT (0), connectez le cordon d'alimentation à votre barbecue. Branchez ensuite le cordon d'alimentation sur une prise électrique correctement mise à la terre et protégée par un disjoncteur de fuite à la terre (GFCI).

REMARQUE : l'aspect de la prise peut varier selon la région.



AVERTISSEMENT ! RISQUE DE CHOC ÉLECTRIQUE
UNE TENSION DANGEREUSE EST PRÉSENTE ET ELLE PEUT PROVOQUER UN CHOC, UNE BRÛLURE OU LA MORT.

- UNE PROTECTION PAR DISJONCTEUR DE FUITE À LA TERRE (GFCI) DOIT ÊTRE FOURNIE SUR LES CIRCUITS OU LES PRISES À UTILISER POUR LE FONCTIONNEMENT DE CE BARBECUE TRAEGER.



Pour ajouter des granules, ouvrez le couvercle de la trémie et vérifiez s'il y a des corps étrangers dans la vis sans fin. Remplissez la trémie de granules au moins jusqu'à la grille de sécurité et fermez le couvercle.

UTILISEZ UNIQUEMENT DES GRANULES À BOIS DUR TRAEGER. Ce produit est développé et réglé en utilisant uniquement des granules Traeger. Les granules Traeger sont fabriqués pour répondre à des normes strictes de qualité et de performance. L'utilisation de granules non fabriqués par Traeger peut entraîner des performances irrégulières, une saveur médiocre et des écarts de température.



Appuyez sur l'interrupteur d'alimentation principal, situé à l'arrière du boîtier de la vis sans fin, pour mettre en MARCHÉ (I). Appuyez sur la molette de sélection pour réveiller le panneau de commande. « TRAEGER » défilera sur l'écran, indiquant que le barbecue est allumé.

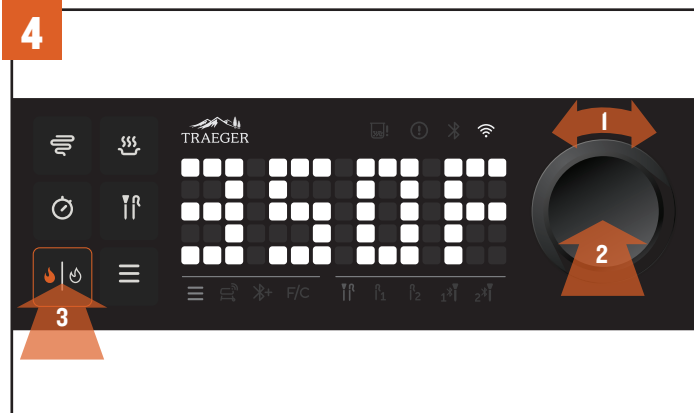

Tournez la molette de sélection pour régler la température du barbecue à 350 °F (177 °C), puis appuyez sur la molette. Appuyez sur le bouton d'allumage/extinction.



CONSEIL DE PRO : ce processus de culottage est important pour garantir le bon fonctionnement du barbecue. Assurez-vous que tous les composants internes ont été correctement installés avant ce cycle de culottage et qu'aucun aliment ne se trouve sur les grilles du barbecue pendant ce processus.

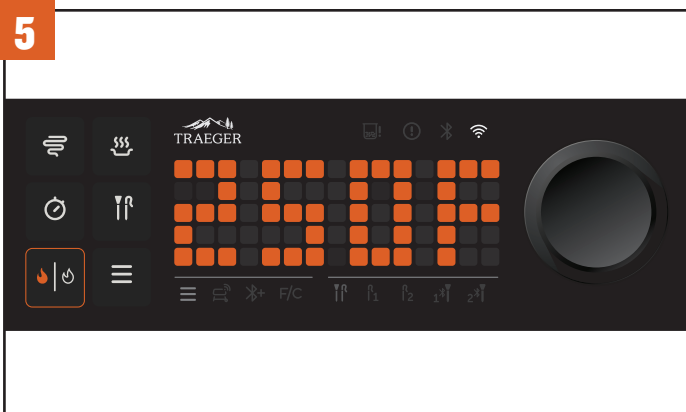

5 La température du barbecue s'affichera à mesure qu'elle augmentera jusqu'à la température réglée.

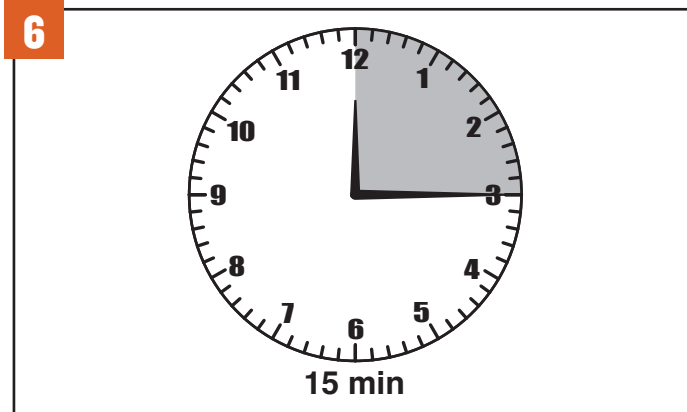

6 Une fois que le barbecue a atteint 350 °F (177 °C), laissez-le fonctionner pendant 15 minutes. Pendant le culottage du barbecue, vous pouvez observer une fumée et des cendres foncées ou excessives ; cela est normal et sera moins important lors des prochains démarrages.

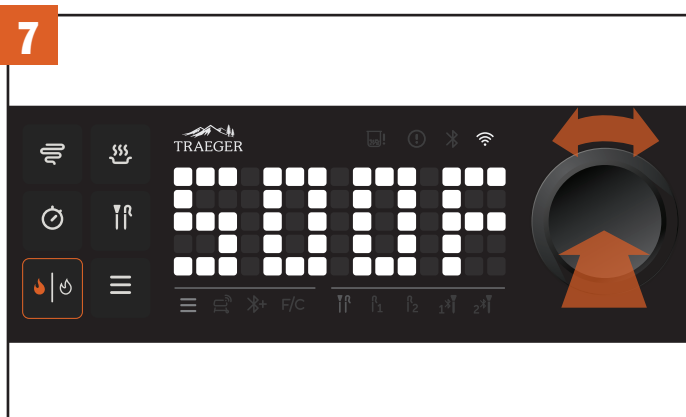

7 Après 15 minutes à 350 °F (177 °C), augmentez la température à 500 °F (260 °C).

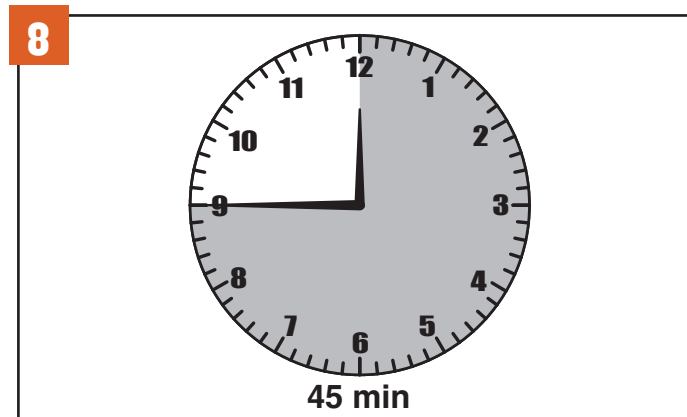

8 Une fois que le barbecue a atteint 500 °F (260 °C), laissez-le fonctionner pendant 45 minutes supplémentaires pour vous assurer que le culottage est terminé correctement.
REMARQUE : atteindre la température de culottage pour la première fois peut prendre jusqu'à une heure.



CULOTTAGE DE VOTRE BARBECUE SUITE

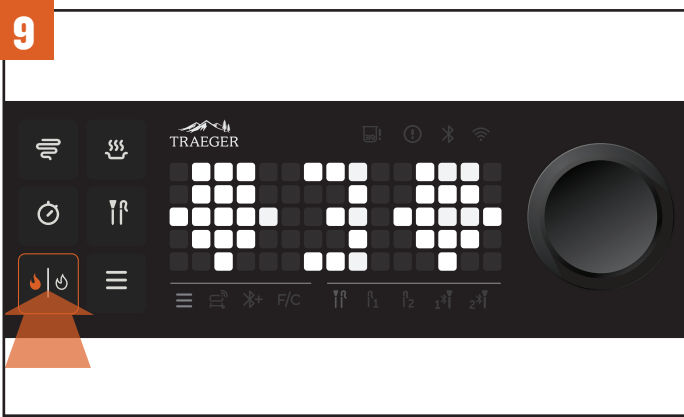

Après 45 minutes à 500 °F (260 °C), éteignez le barbecue et laissez le cycle d'extinction se terminer. Pour éteindre votre barbecue, appuyez sur le bouton d'allumage/extinction ou sur la molette de sélection maintenez enfoncé pendant trois secondes jusqu'à ce que l'écran affiche l'animation d'extinction.

REMARQUE : lancez toujours un cycle d'extinction après chaque cuisson.

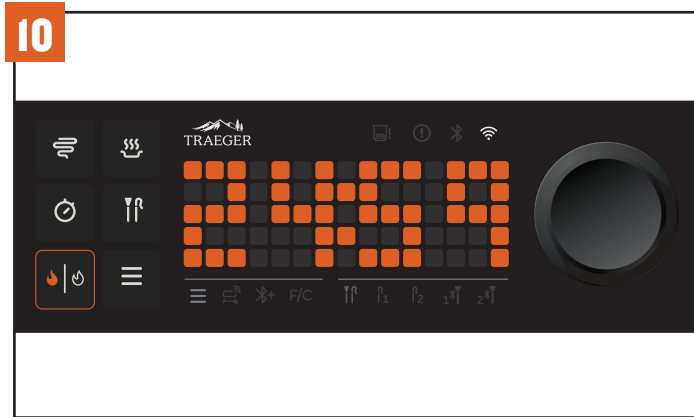

Un compte à rebours démarre pendant que le barbecue s'éteint. Vous entendrez le ventilateur continuer à fonctionner.

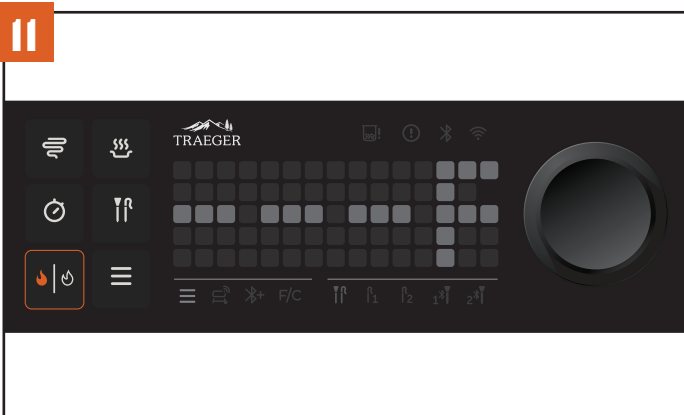

Une fois ce compte à rebours terminé, le cycle d'extinction est terminé.

REMARQUE : il est normal d'observer des cendres sur le plateau d'égouttement et/ou les grilles du barbecue après le culottage. Essayez simplement les cendres sur les grilles du barbecue avant votre première cuisson.

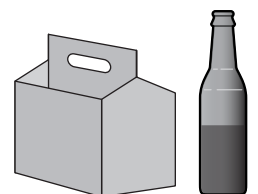

COMMENT CUISINER SUR VOTRE TRAEGER

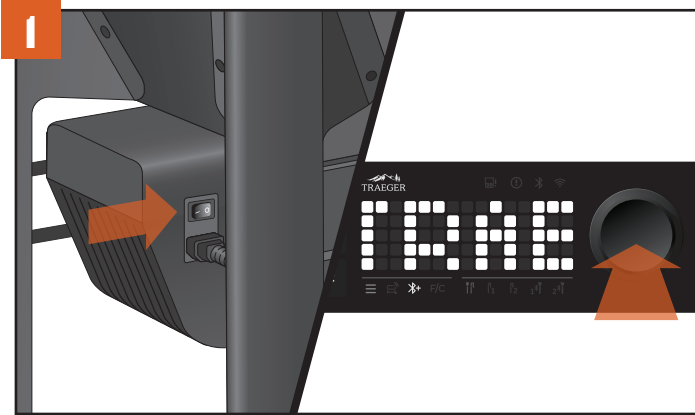

Avec le couvercle fermé, appuyez sur l'interrupteur d'alimentation principal situé à l'arrière du boîtier de la vis sans fin pour le mettre en position **MARCHE (I)**. Appuyez sur la molette de sélection ou appuyez sur le bouton d'allumage/ extinction pour sortir le barbecue de veille. Un écran de démarrage apparaîtra après quelques secondes lorsque le barbecue s'allumera.

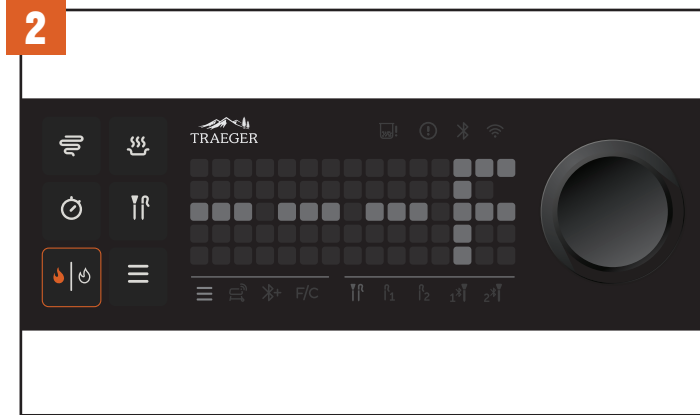

La matrice de points affiche trois tirets et F ou C. Il s'agit de l'écran d'accueil lorsque votre barbecue est inactif. Vous pouvez régler une température de barbecue directement depuis cet écran.

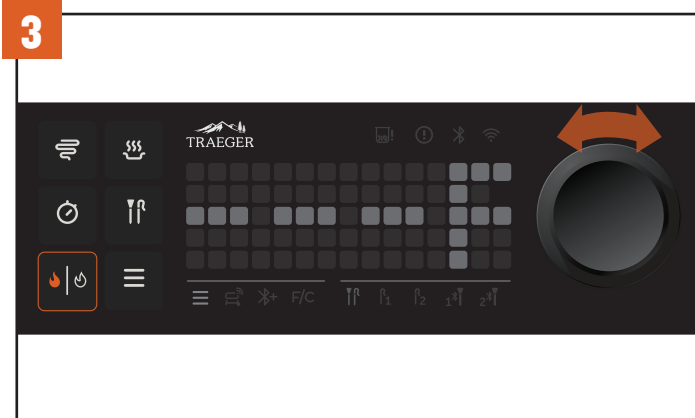

Pour sélectionner une température, tournez la molette de sélection vers la droite pour augmenter la température ou vers la gauche pour la diminuer.

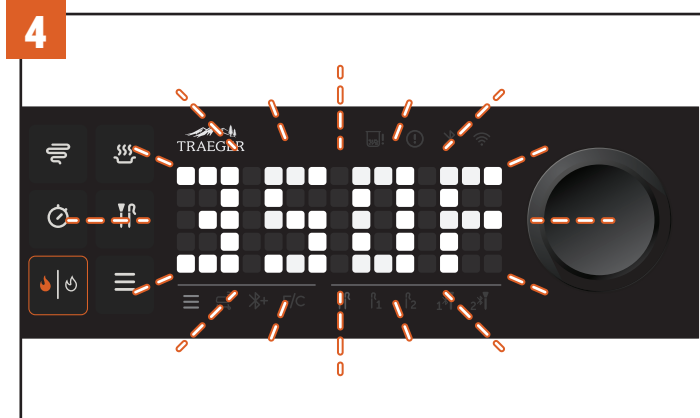

La température sélectionnée clignotera.

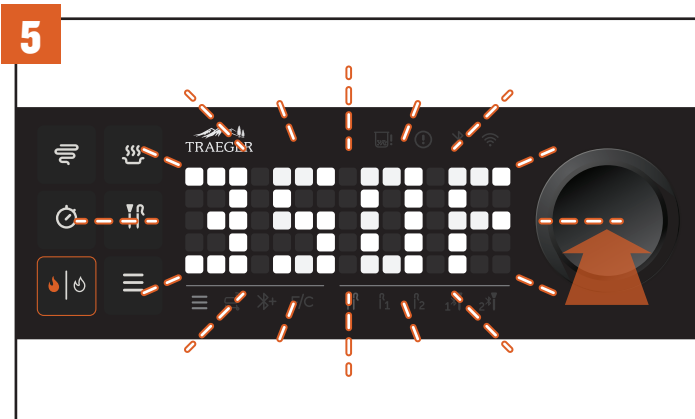

Pendant que la température clignote, appuyez sur le centre de la molette de sélection pour sélectionner la température souhaitée.

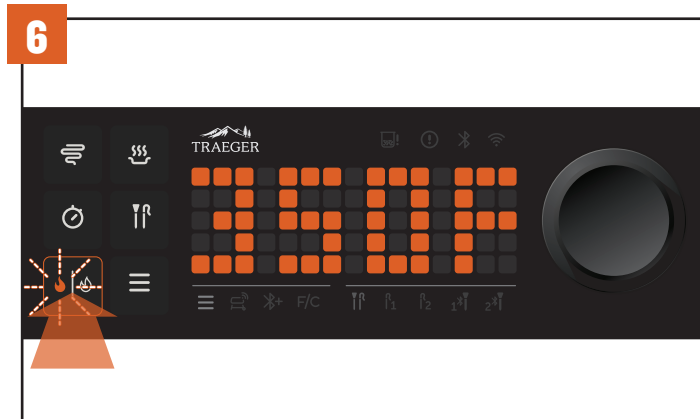

Une fois votre température sélectionnée, la température passera du blanc à l'orange, indiquant que votre température définie est verrouillée. Le bouton d'allumage/extinction clignotera maintenant. Appuyez sur ce bouton pour démarrer l'allumage. Le barbecue va maintenant s'allumer et préchauffer automatiquement pour atteindre la température que vous avez définie.

COMMENT CUISINER SUR VOTRE TRAEGER (SUITE)

7



Pendant que le barbecue préchauffe, le panneau de commande affichera une flèche animée à côté de la température, indiquant le mode de préchauffage. La température actuelle augmentera par incréments de 5 degrés à mesure que le barbecue chauffe.

8

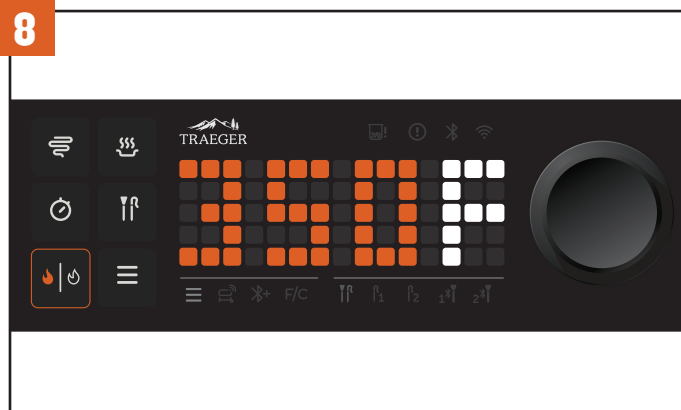

Une fois que le barbecue a atteint la température définie, le panneau de commande n'affichera plus l'animation de la flèche de préchauffage et la température actuelle continuera de se situer à +/- 25 °F (+/- 4 °C) de la température définie. Ces petites variations de température sont tout à fait normales pour l'utilisation quotidienne d'un barbecue à granules à bois et sont le résultat naturel de l'aération et de la surveillance de la flamme. N'ouvrez pas le couvercle et ne réglez pas la température réglée avant qu'elle ne soit atteinte.

9

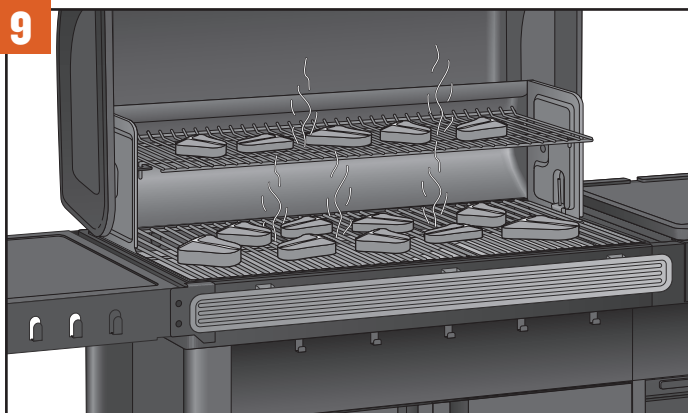

Vous pouvez maintenant charger votre barbecue d'aliments et commencer à cuisiner.

CONSEILS :

- Gardez le barbecue fermé pendant la phase de préchauffage afin qu'il atteigne la température réglée.
- Attendez que le cycle de préchauffage soit terminé avant de commencer la cuisson de vos aliments. Ouvrir le couvercle avant que la température souhaitée ne soit atteinte peut vous empêcher d'obtenir les meilleurs résultats de cuisson.
- Ajouter des aliments trop tôt peut faire en sorte que le barbecue prenne plus de temps que d'habitude pour atteindre la température souhaitée.
- **Les barbecues Traeger Woodridge fournissent des relevés de température en temps réel par incréments de cinq degrés, et vous devez vous attendre à voir des fluctuations de température.**



CONSEIL DE PRO : la cuisson des aliments à la température interne souhaitée est le secret le mieux gardé pour obtenir d'excellents résultats.



REMARQUES





MONTAGEANLEITUNG

WOODRIDGE ELITE HOLZPELLETGRILL



**HIER SCANNEN
FÜR EINE SCHRITTWEISE
ANIMIERTE
ANLEITUNG**

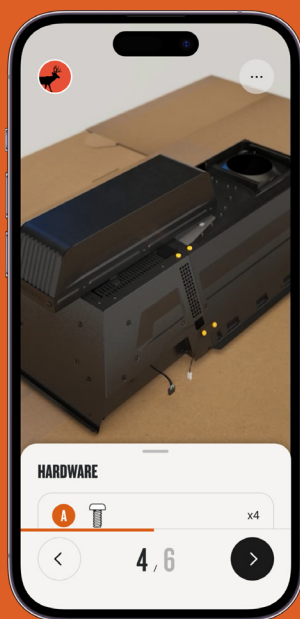

EINE DER HAUPTURSACHEN FÜR BRÄNDE IST DIE NICHT-EINHALTUNG DER ERFORDERLICHEN ABSTÄNDE (LUFTRÄUME) ZU BRENNBAREN MATERIALIEN. ES IST ÄUSSERST WICHTIG, DASS DIESES PRODUKT NUR GEMÄSS DIESER ANLEITUNG AUFGEBAUT WIRD.

WICHTIG: ANLEITUNG FÜR SPÄTERE VERWENDUNG AUFBEWAHREN. ANLEITUNG SORGFÄLTIG DURCHLESEN.

T18985

©2025 TRAEGER PELLET GRILLS LLC.
ALLE RECHTE VORBEHALTEN.

TRAEGER PELLET GRILLS LLC

533 South 400 West
Salt Lake City, UT 84101

TRAEGER.COM

VOR DER MONTAGE

BITTE LESEN SIE DIESE MONTAGEANLEITUNG UND DIE BETRIEBSANLEITUNG VOR DER INSTALLATION UND VERWENDUNG IHRES TRÄGERGRILLS. DIE NICHTBEACHTUNG DER ANWEISUNGEN IN DIESER MONTAGEANLEITUNG UND DER BENUTZERHANDBUCH KANN ZU SACHSCHÄDEN, PERSONENSCHÄDEN ODER SOGAR ZUM TOD FÜHREN.

Achten Sie darauf, dass beim Grillen ein Mindestabstand von 50,8 cm (20 Zoll) zu brennbaren Gegenständen in der Nähe besteht, z. B. zu Holzgeländern, Hausverkleidungen, Fensterrahmen, Möbeln, Bäumen, Mülleimern usw. Installieren und betreiben Sie diesen Grill nicht auf brennbaren Böden oder Oberflächen, in Innenräumen oder unter brennbaren Zimmerdecken oder Überhängen. Weitere Anweisungen und Warnungen finden Sie in der Benutzerhandbuch.

MONTAGE-BEREICH

PROFI-TIPP: Montieren Sie den Grill auf der Unterseite des Versandkartons, um Kratzer zu vermeiden.

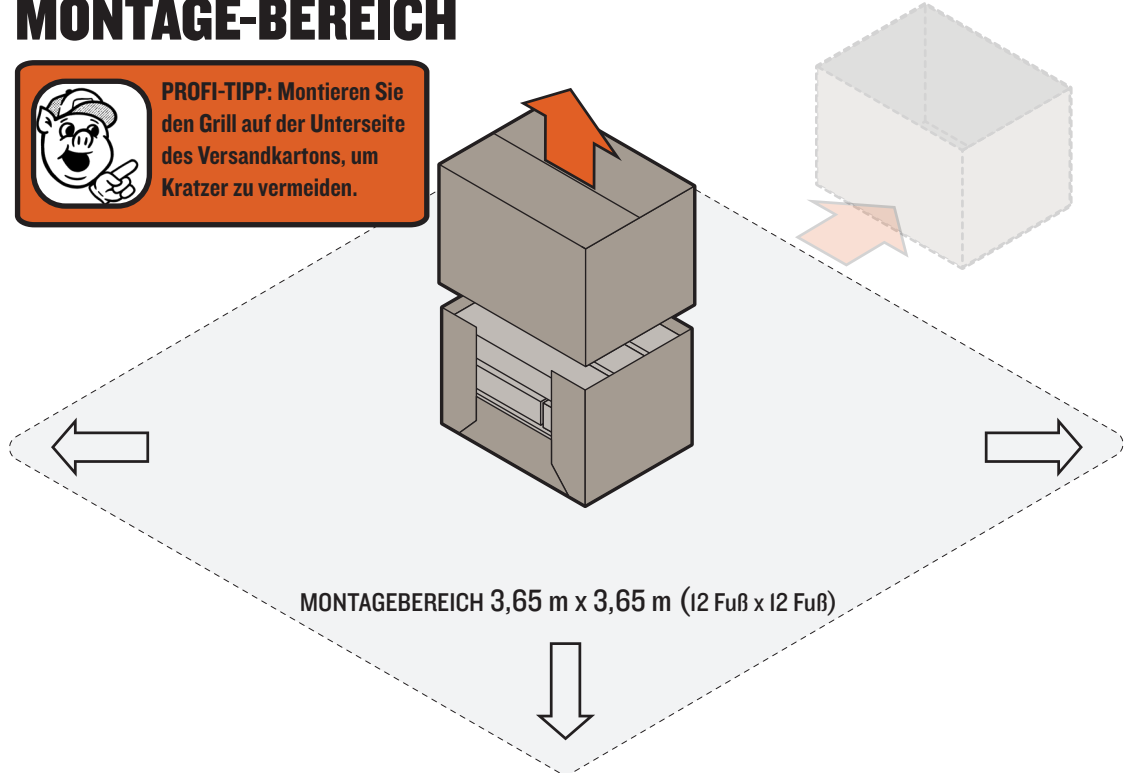

PROFI-TIPP: Wir empfehlen, den Aufbau des Grills zu zweit durchzuführen.

MONTAGE

Nachdem alle Komponenten ausgepackt sind, legen Sie die Teile auf die Unterseite des Versandkartons.

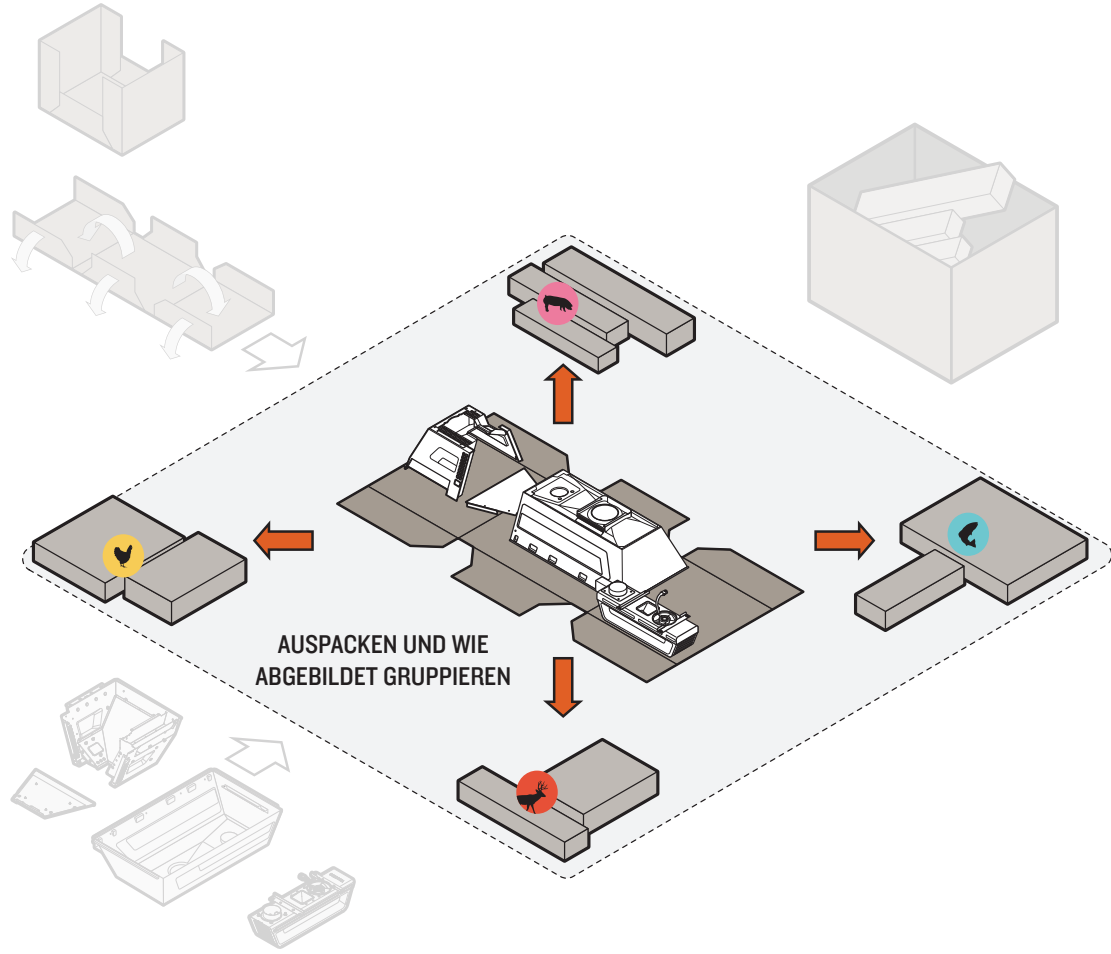

GRUPPIEREN SIE DIE SCHACHTELN ANHAND IHRER KENNZEICHNUNGEN, WIE UNTEN DARGESTELLT:

-  **FÄCHER & BEINE**
-  **UNTERSCHRANK UND ROLLEN**
-  **WEGKLAPPBARE SEITLICHE ABLAGE, BASIS UND BEDIENFELD**
-  **DECKEL & INNENTEILE DES GRILLS**



BEFESTIGUNGSTEILE (GESAMTMENGEN)

MASSSTAB 1:1

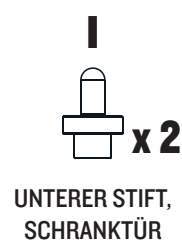
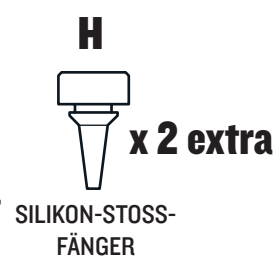
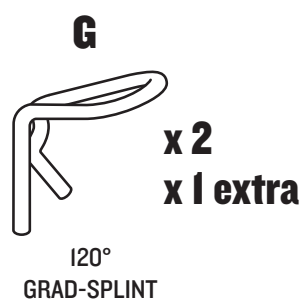
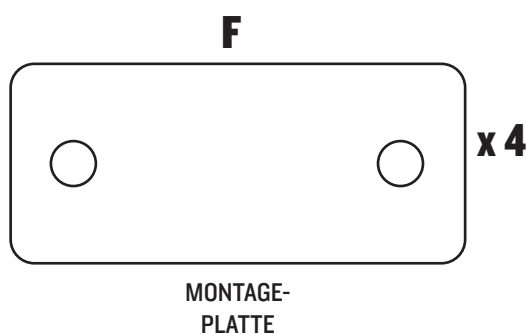
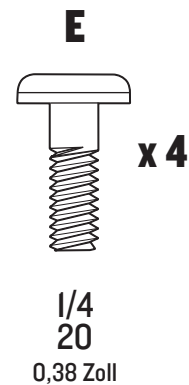
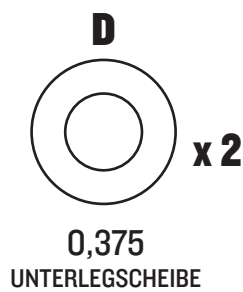
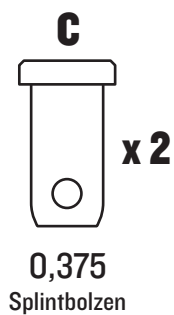
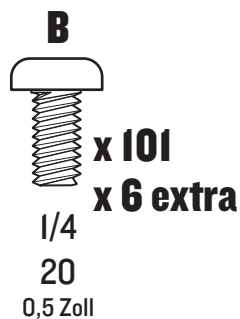
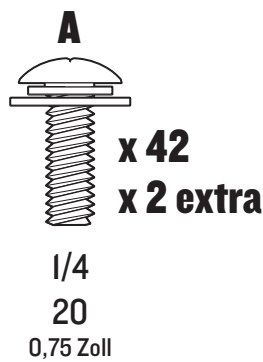



KAPITEL

KAPITEL 1 – SEITE 5 FÄCHER & BEINE

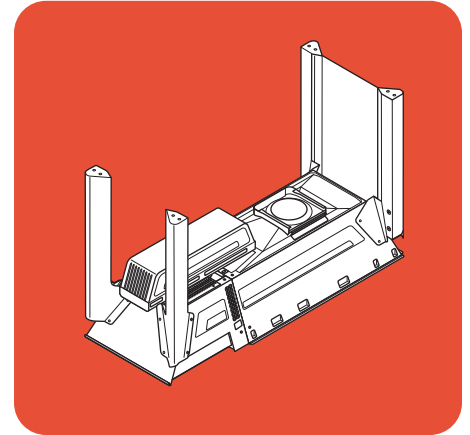

KAPITEL 2 – SEITE 13 UNTERSCHRANK UND ROLLEN

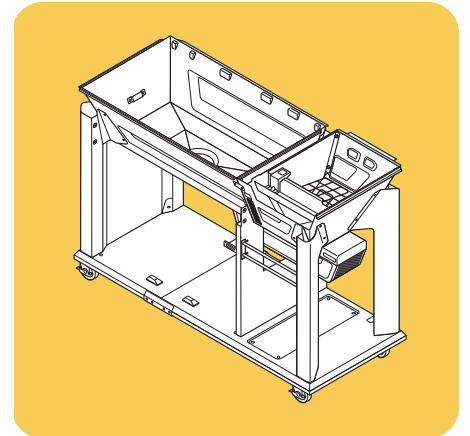

KAPITEL 3 – SEITE 21 WEGKLAPPBARE SEITLICHE ABLAGE, BASIS UND BEDIENFELD

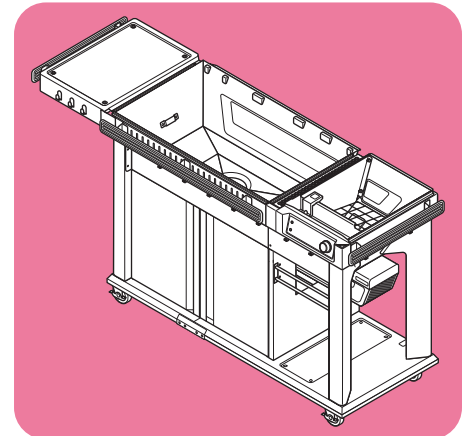

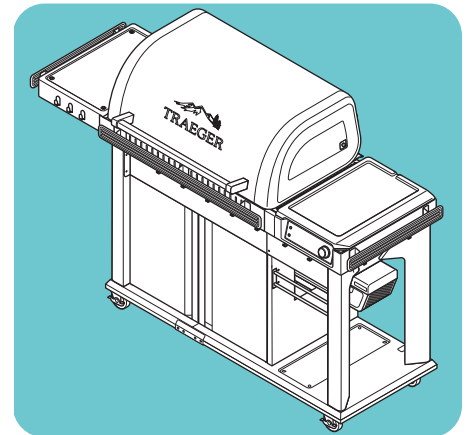

KAPITEL 4 – SEITE 40 DECKEL & INNENTEILE DES GRILLS

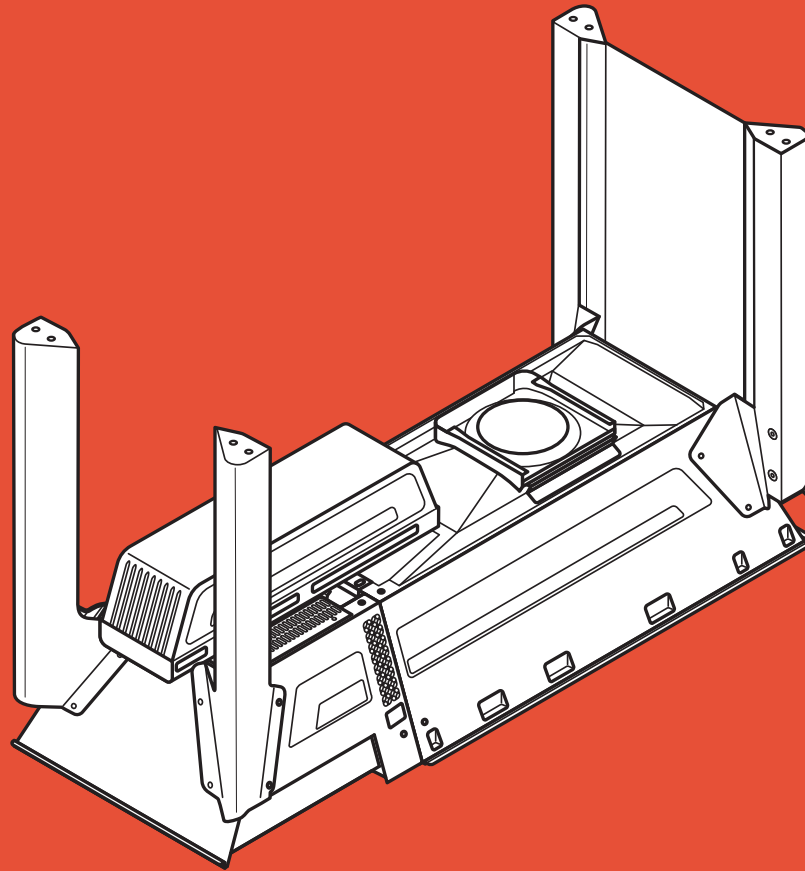

KAPITEL I

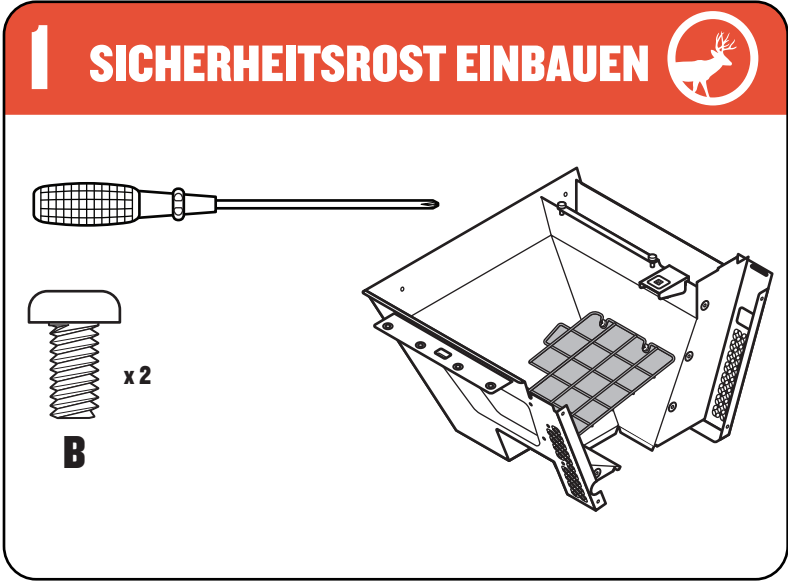
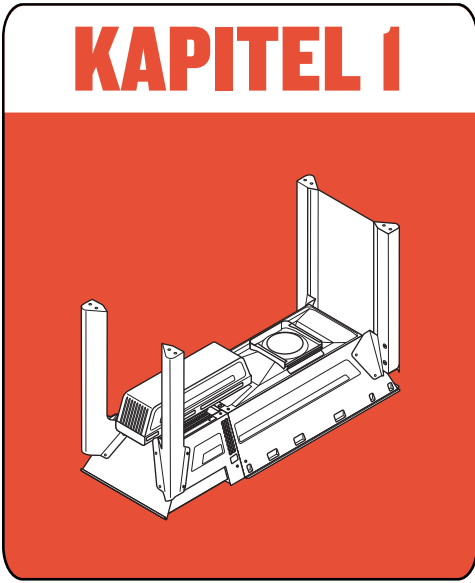

FÄCHER & BEINE

PROFI-TIPP: Ziehen Sie alle Schrauben zunächst handfest an und ziehen Sie sie dann mit einem Schraubendreher fest.



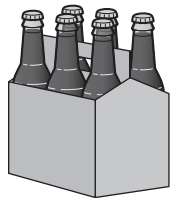
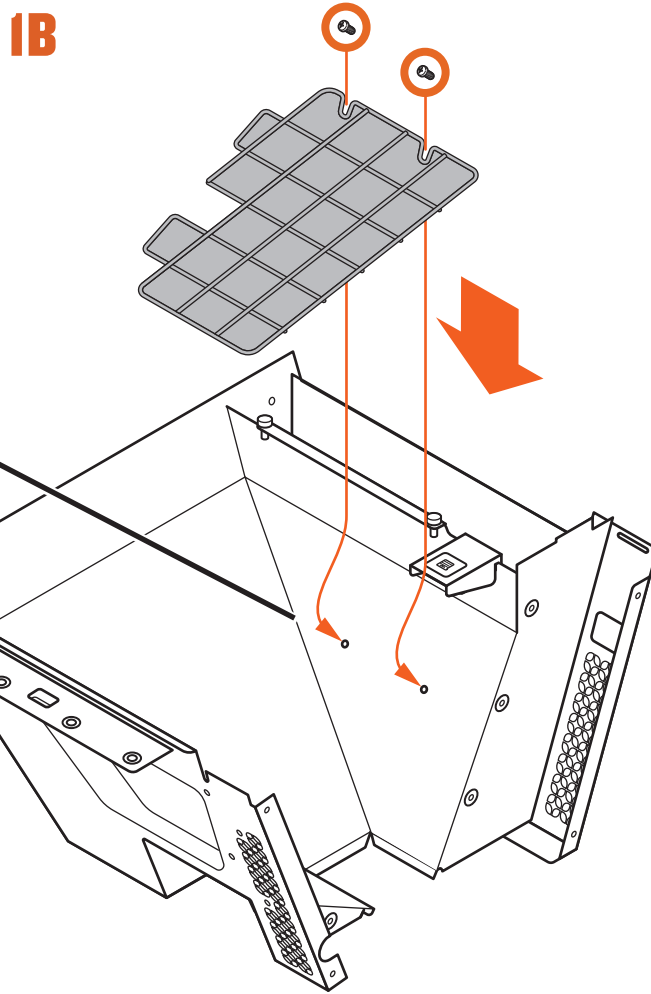
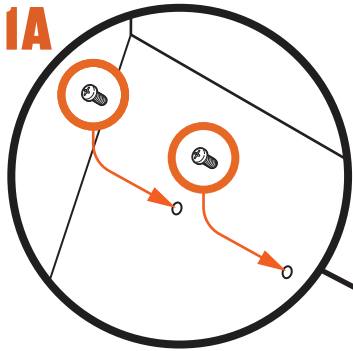

6



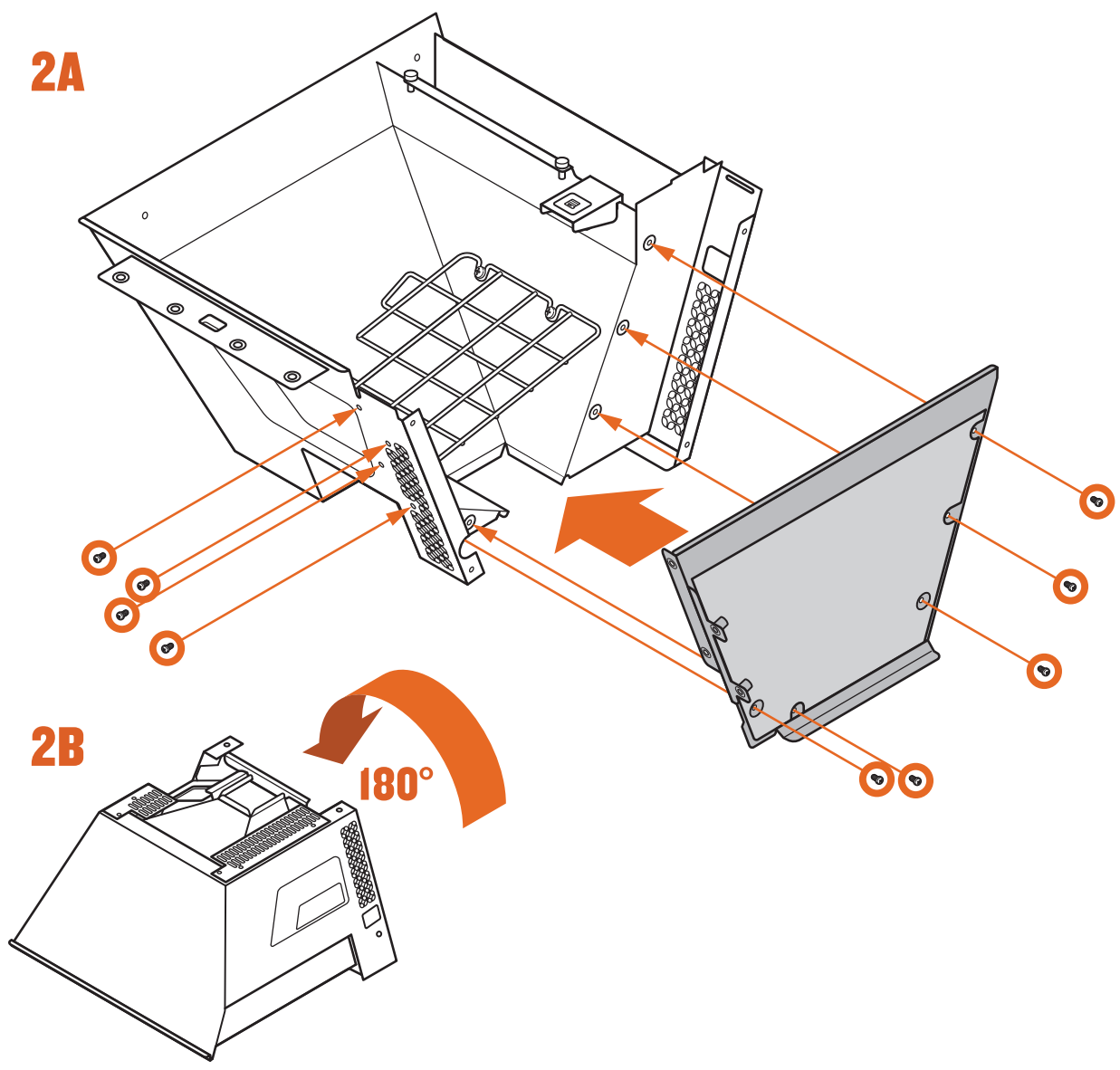
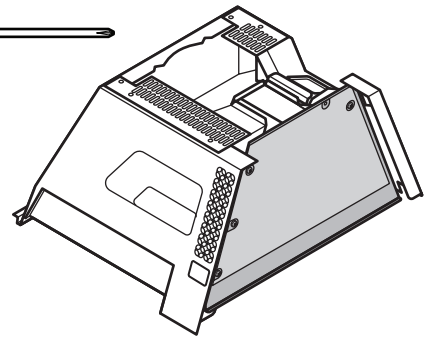
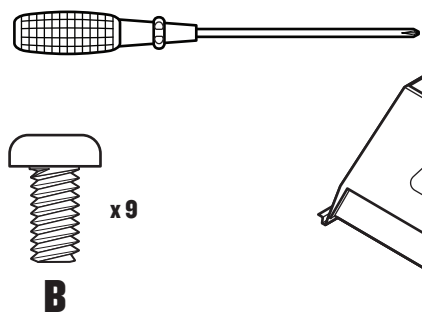

2 PELLETKAMMER ZUSAMMENBAUEN





3A PELLETKAMMER AM GEHÄUSE ANBRINGEN

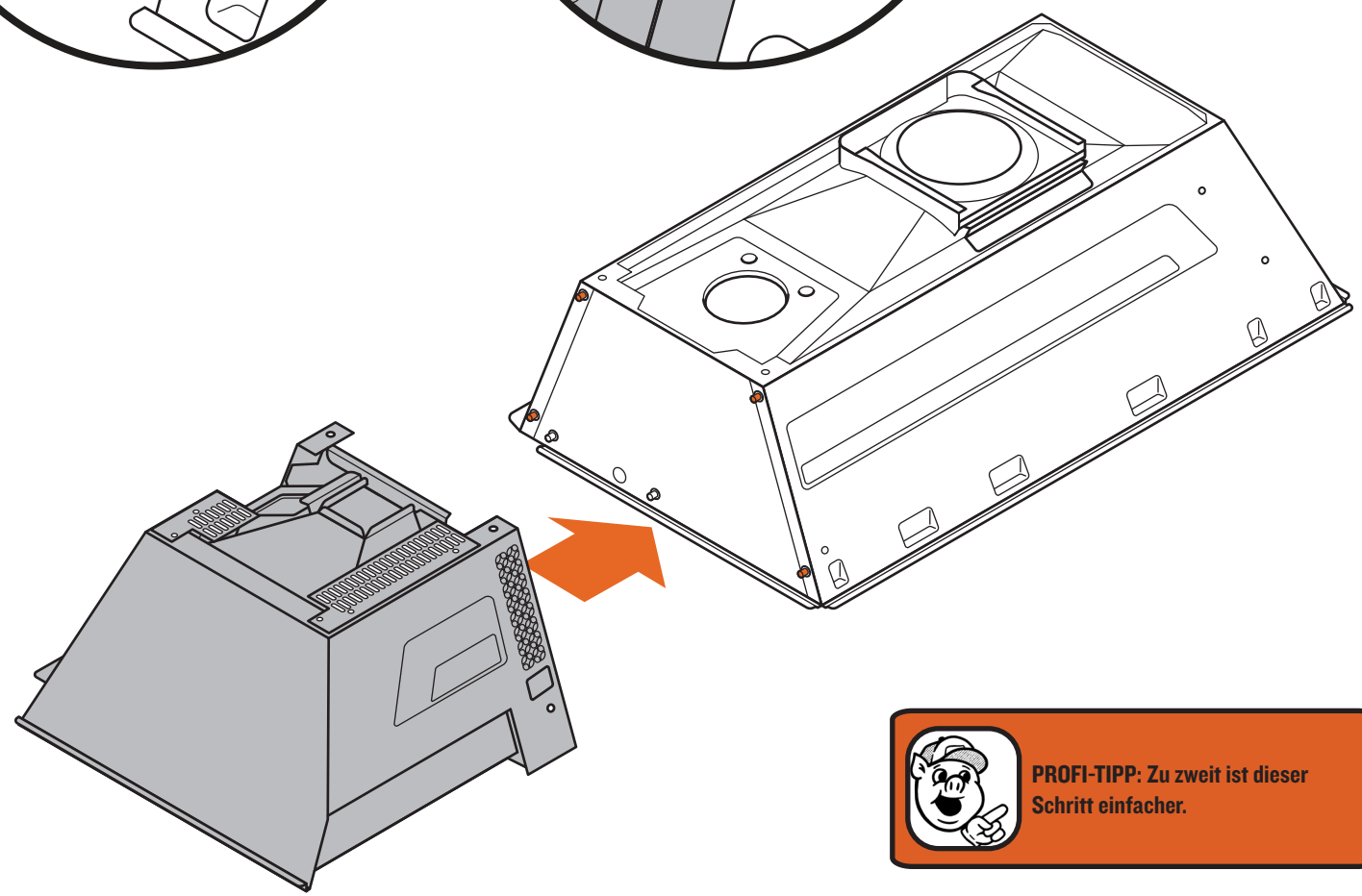
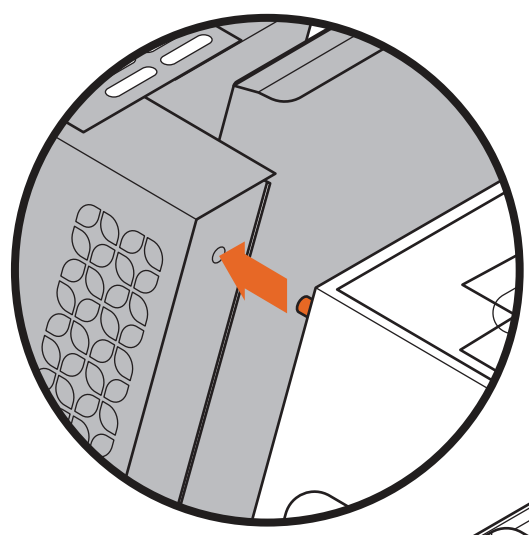
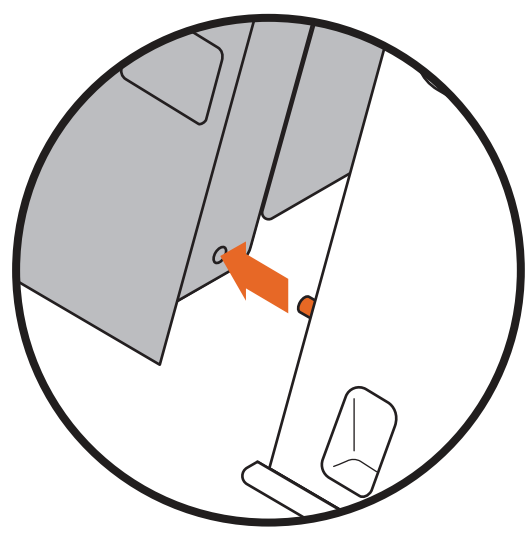
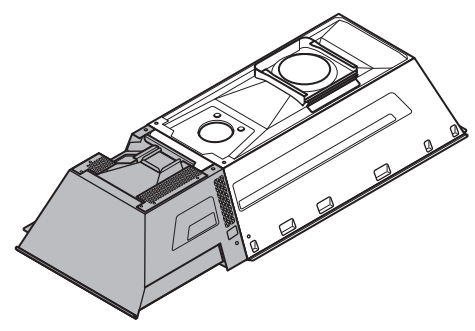



 **PROFI-TIPP:** Zu zweit ist dieser Schritt einfacher.



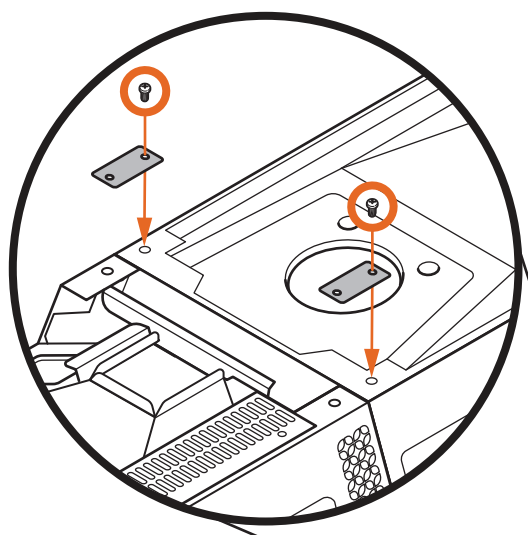
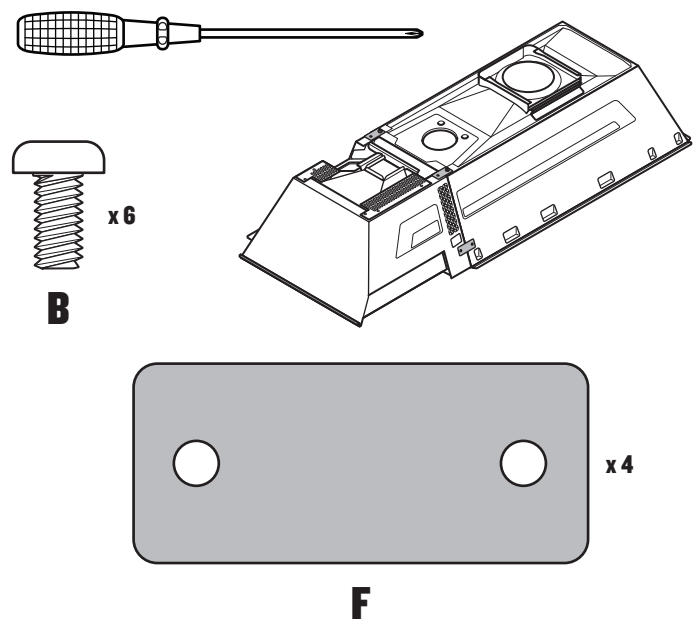

3B PELLETKAMMER AM GEHÄUSE ANBRINGEN



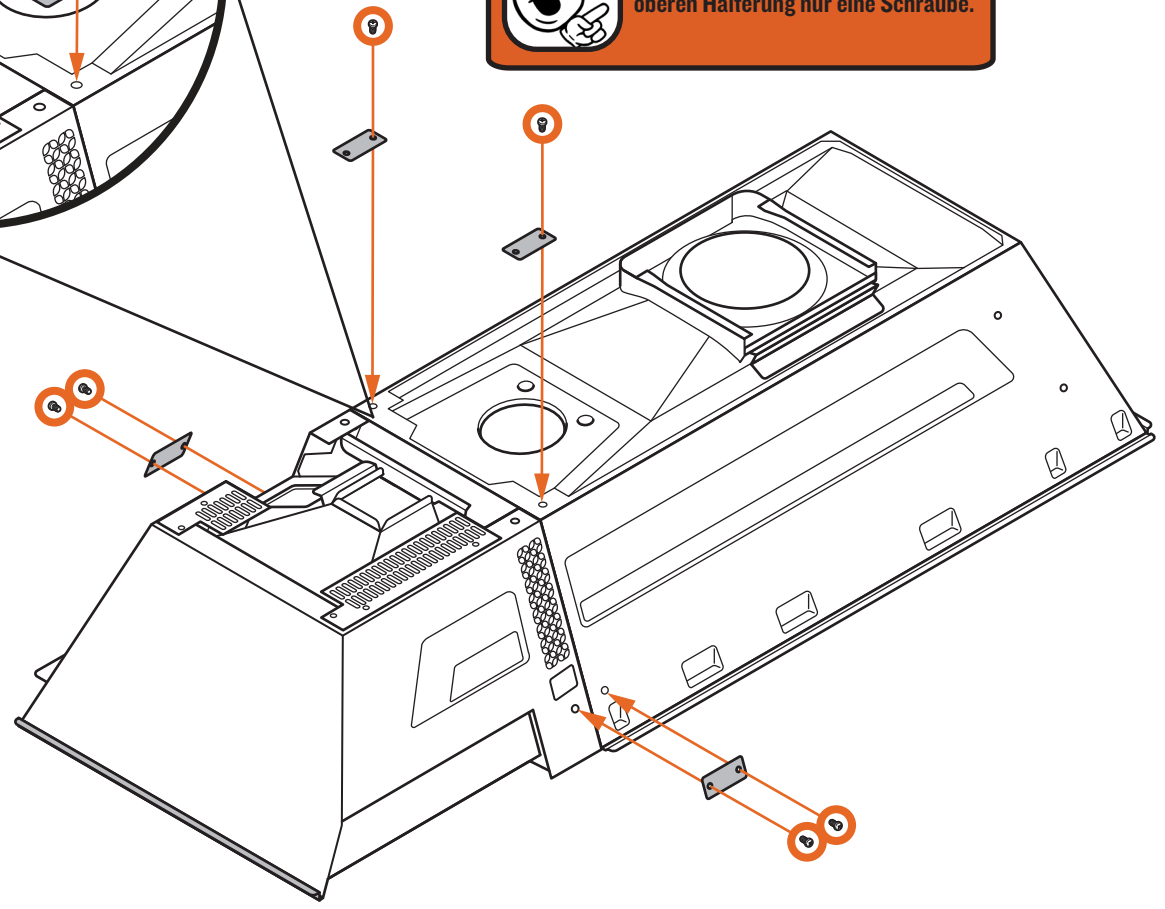

 **PROFI-TIPP:** Montieren Sie in jeder oberen Halterung nur eine Schraube.



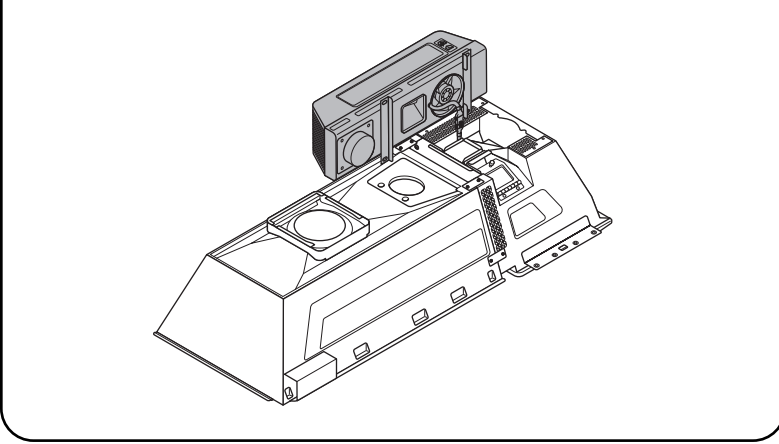
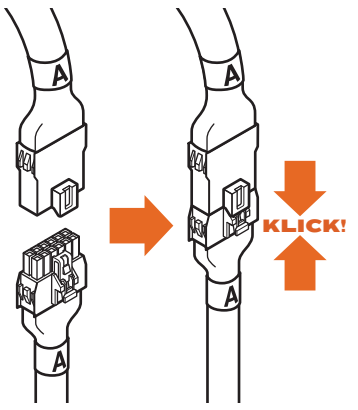

4 FÖRDERSCNECKENGEHÄUSE ANSCHLIESSEN



 **PROFI-TIPP:** Lassen Sie das Förderschneckengehäuse von einer zweiten Person festhalten, während Sie das Kabel anschließen.

 **PROFI-TIPP:** Vergessen Sie nicht, den Bindedraht und das Klebeband zu entfernen, mit denen das Kabel befestigt ist.

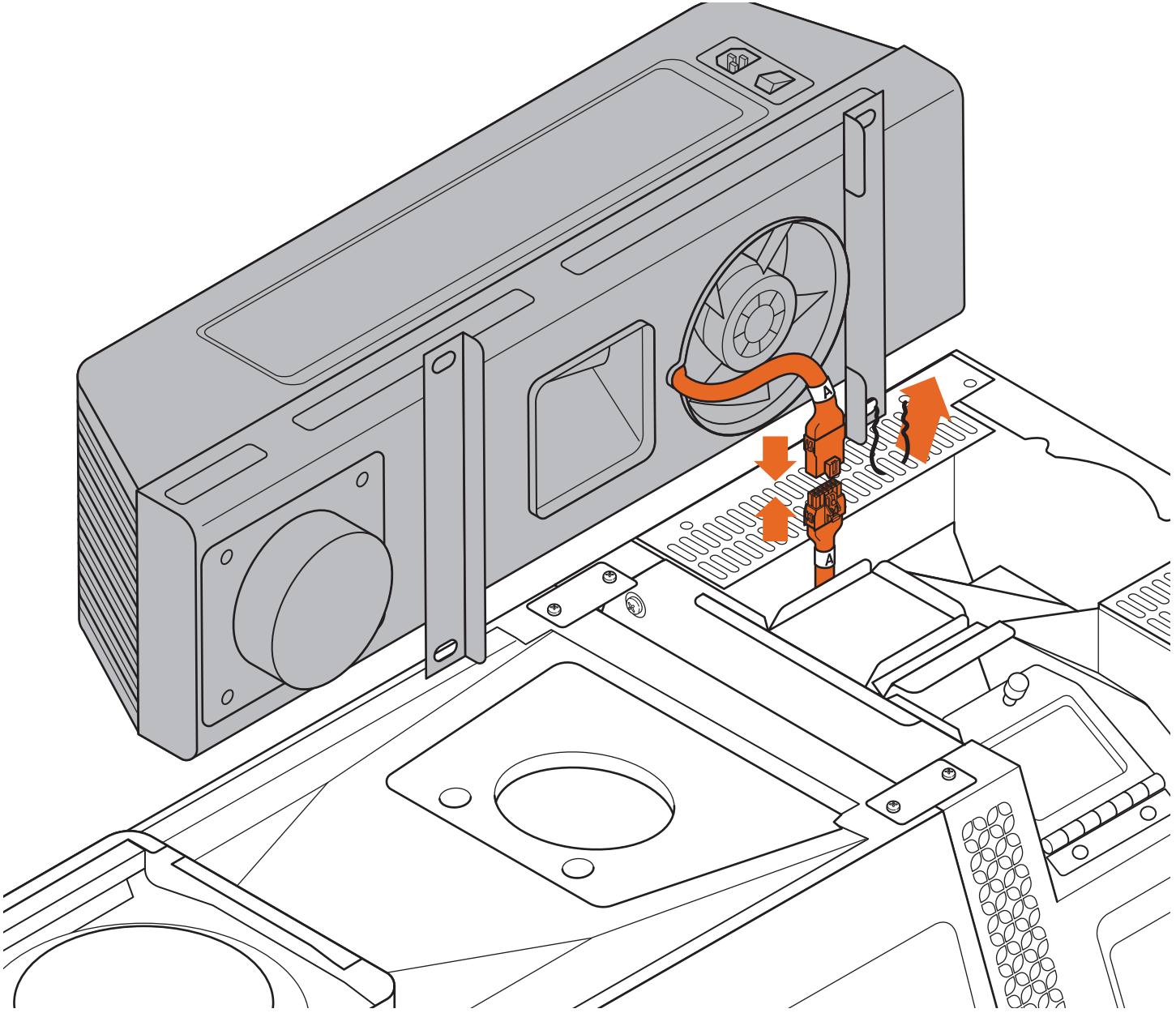



5 FÖRERSCHNECKENGEHÄUSE ANBRINGEN

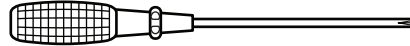

Verwenden Sie jetzt
DIESE Schraube!

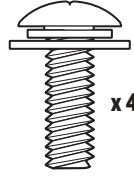

x4

A

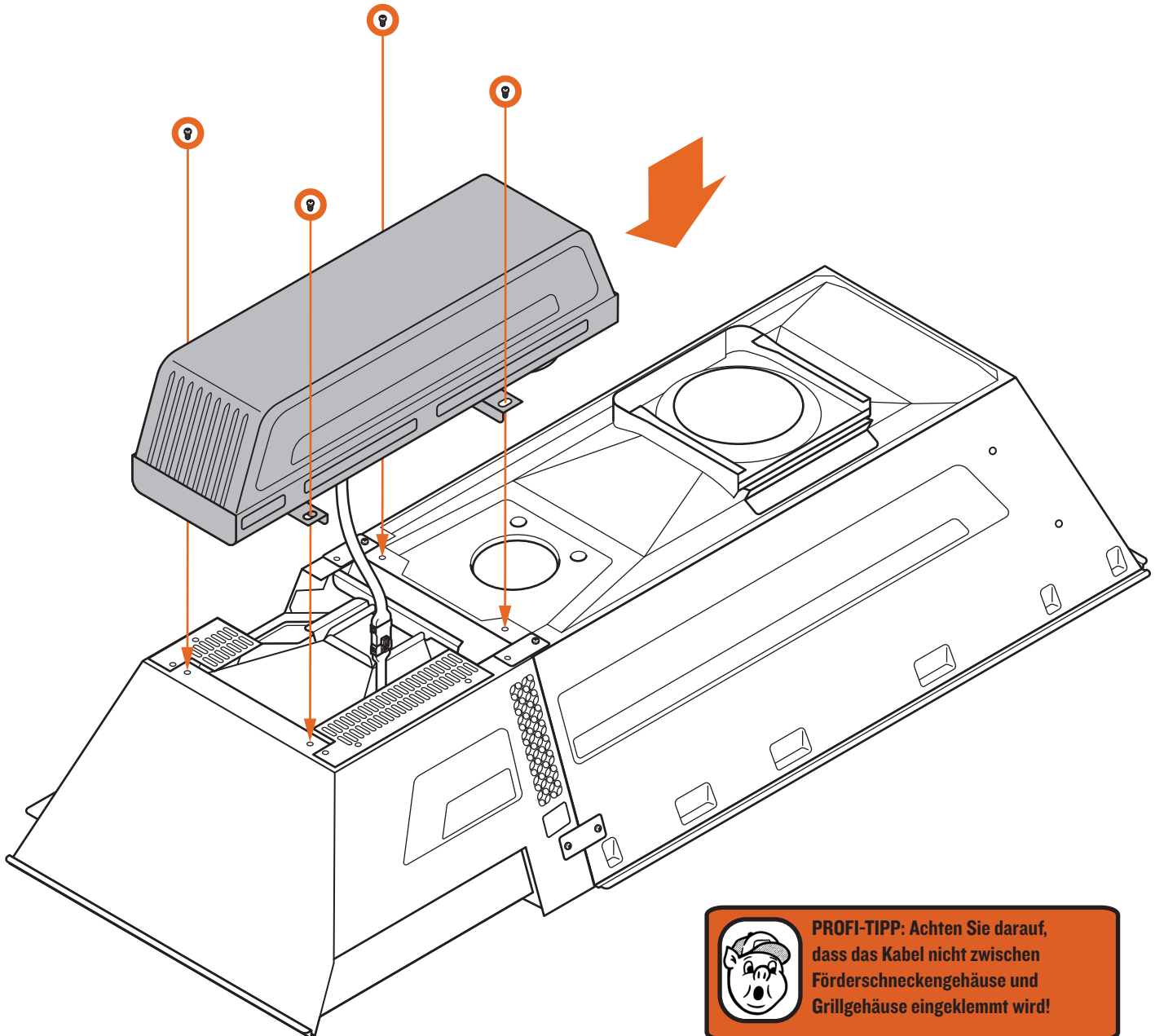
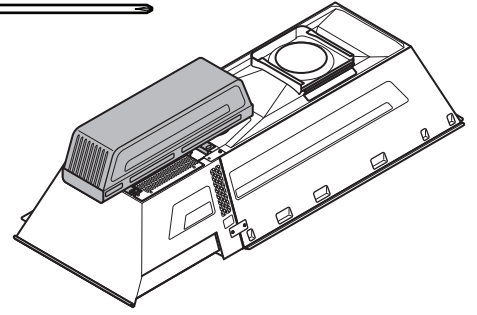

PROFI-TIPP: Achten Sie darauf, dass das Kabel nicht zwischen Förderschneckengehäuse und Grillgehäuse eingeklemmt wird!



6 BEINE ANBRINGEN

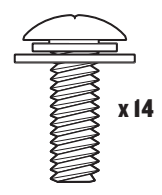
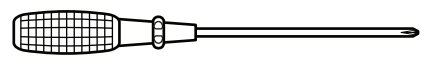

A

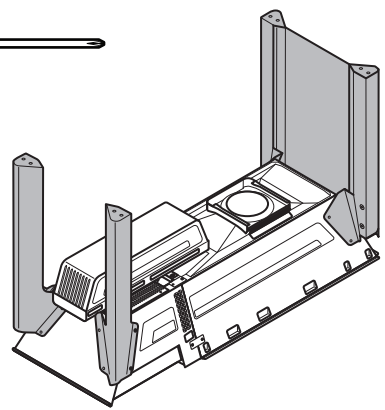

 **PROFI-TIPP:** Richten Sie die Schraubenlöcher in den Standbeinen mit den Schraubenlöchern im Grillgehäuse und in der Pelletkammer aus.

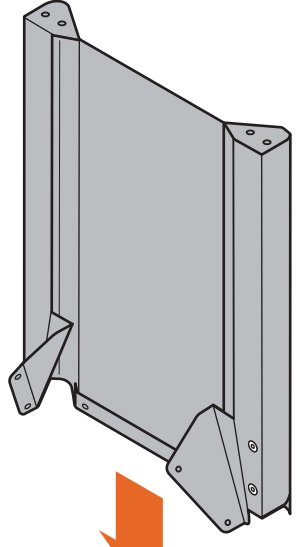

 **PROFI-TIPP:** Sie können die Beine leicht zusammendrücken, um die Schrauben auszurichten, bevor Sie sie mit einem Schraubendreher festziehen.

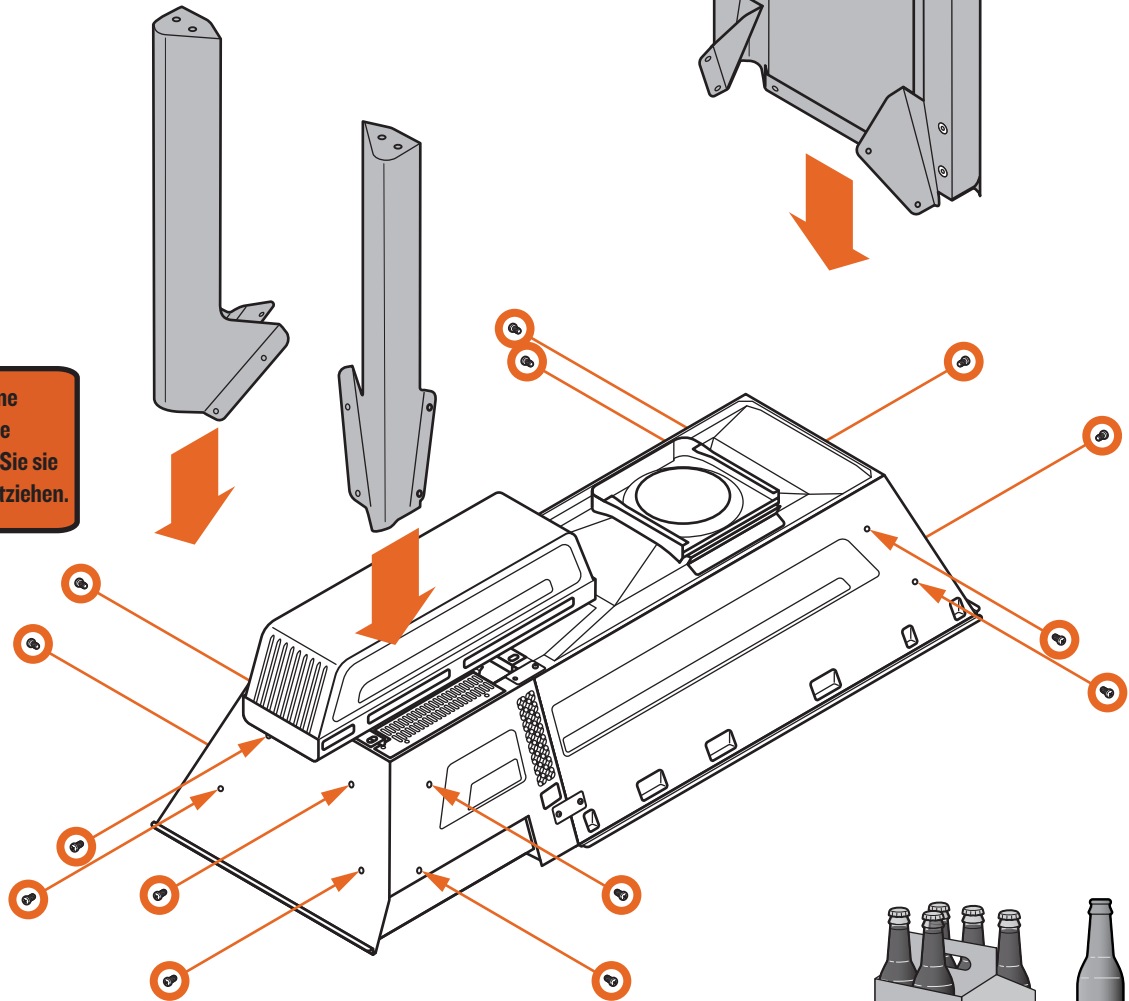

**GUTE ARBEIT!
KAPITEL I ABGESCHLOSSEN!**

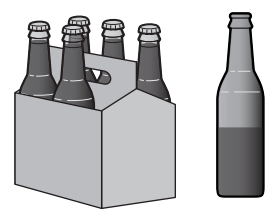

KAPITEL 2

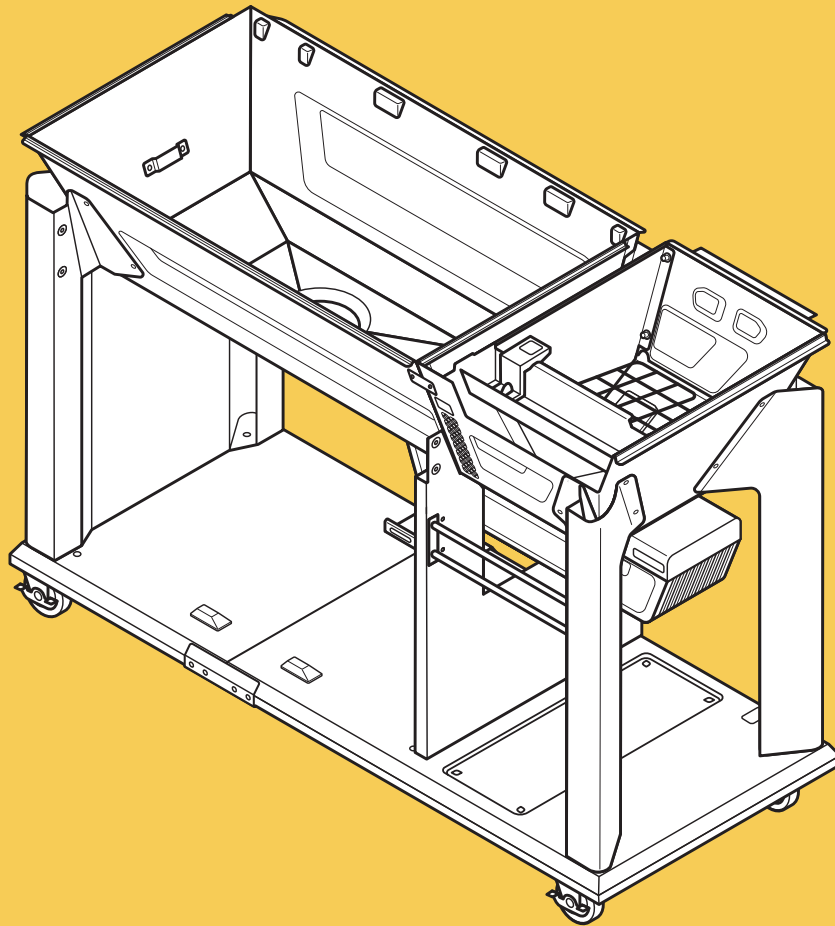

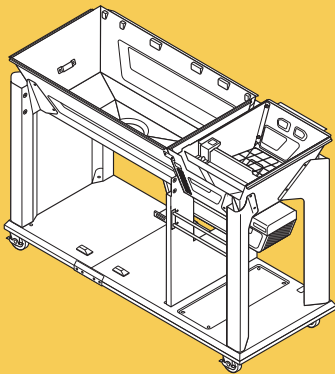

UNTERSCHRANK UND ROLLEN

KAPITEL 2

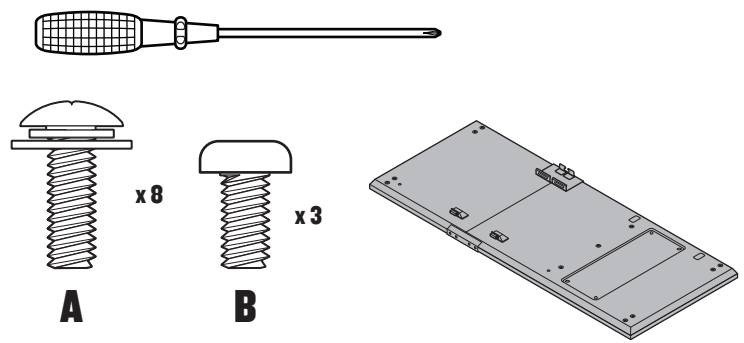

1 BASIS MONTIEREN



 **PROFI-TIPP:** Ziehen Sie alle Schrauben zunächst handfest an und ziehen Sie sie dann mit einem Schraubendreher fest.

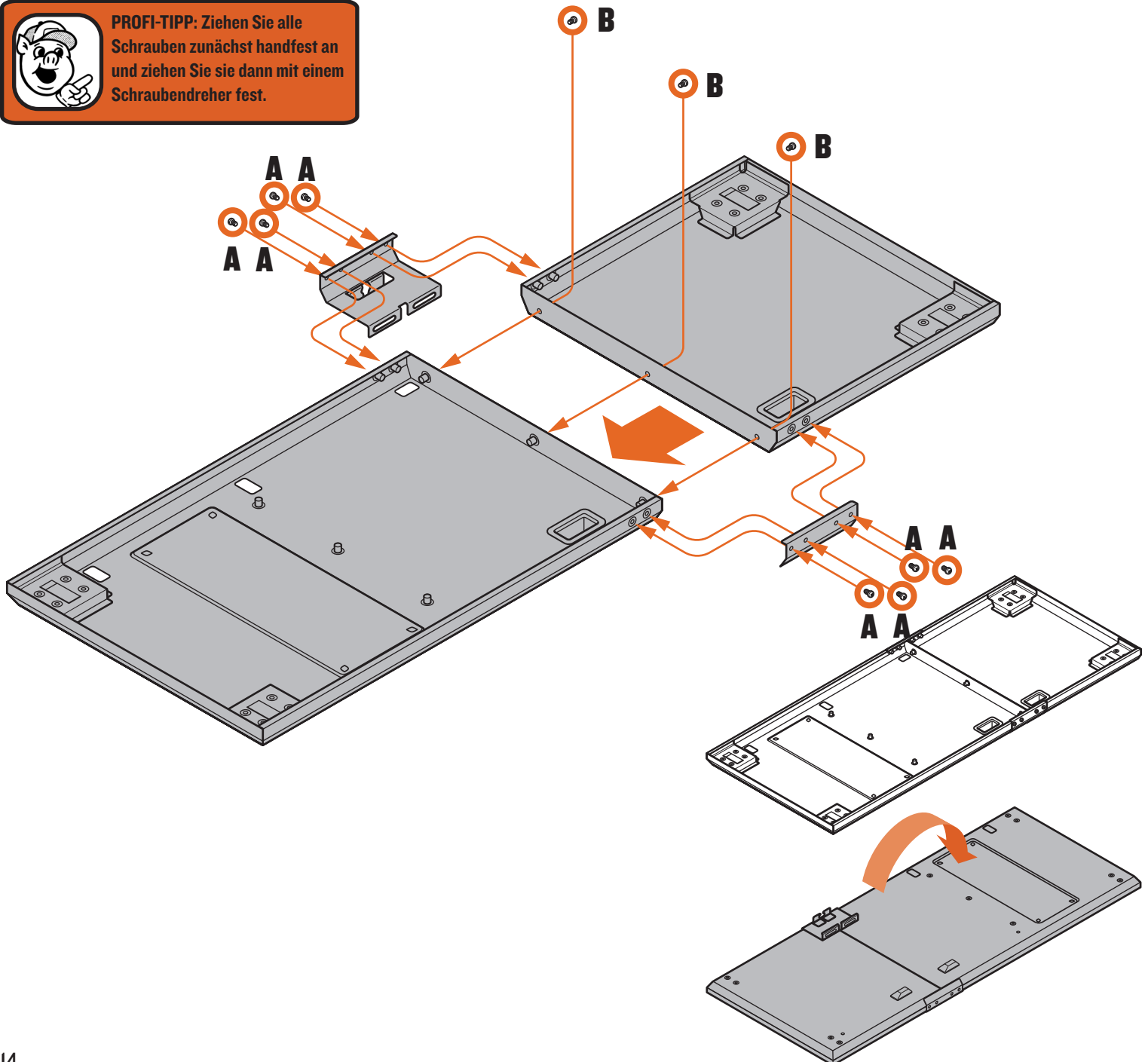



2 MITTELWAND ANBRINGEN

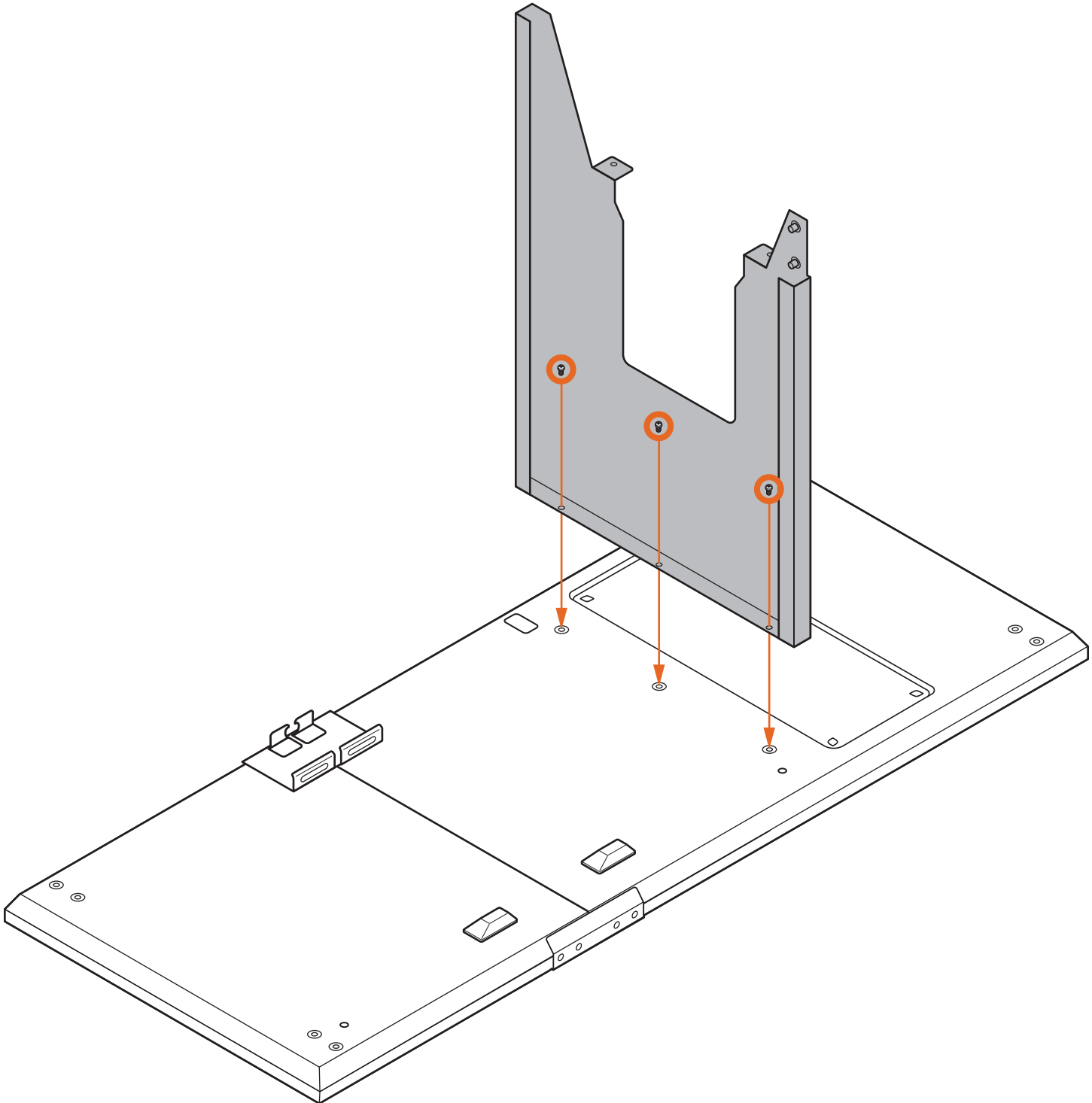
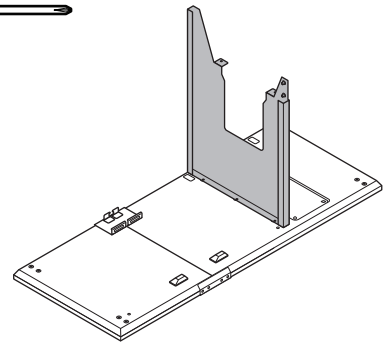
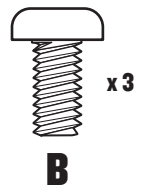
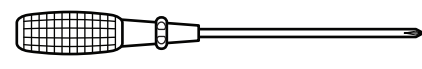



 **PROFI-TIPP:** Lassen Sie sich beim Anheben und Drehen der Basis von einer zweiten Person helfen.

3A BASIS AM GRILLGEHÄUSE ANBRINGEN

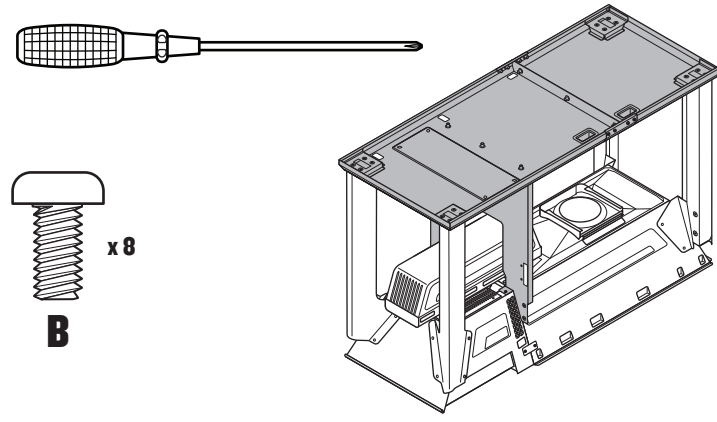
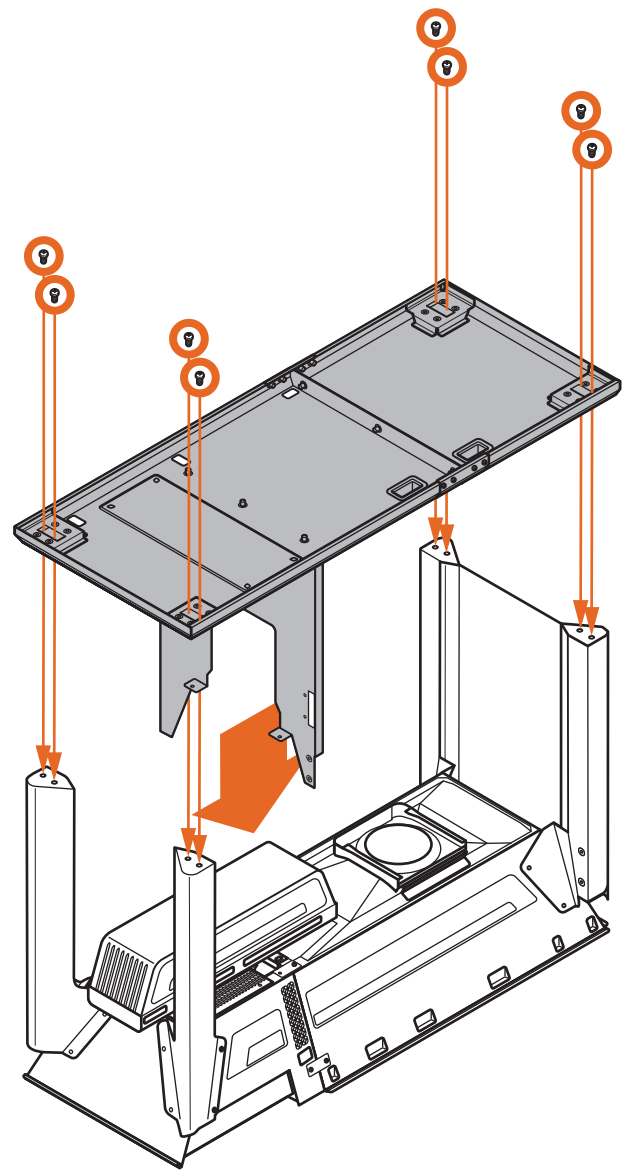
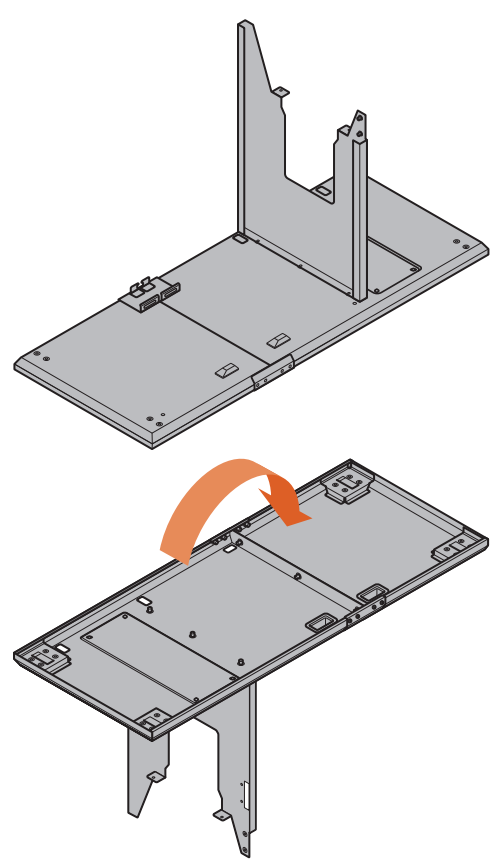



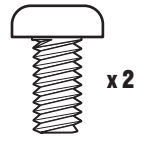
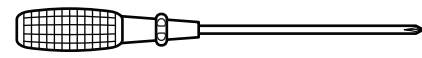

3B BASIS AM GRILLGEHÄUSE ANBRINGEN

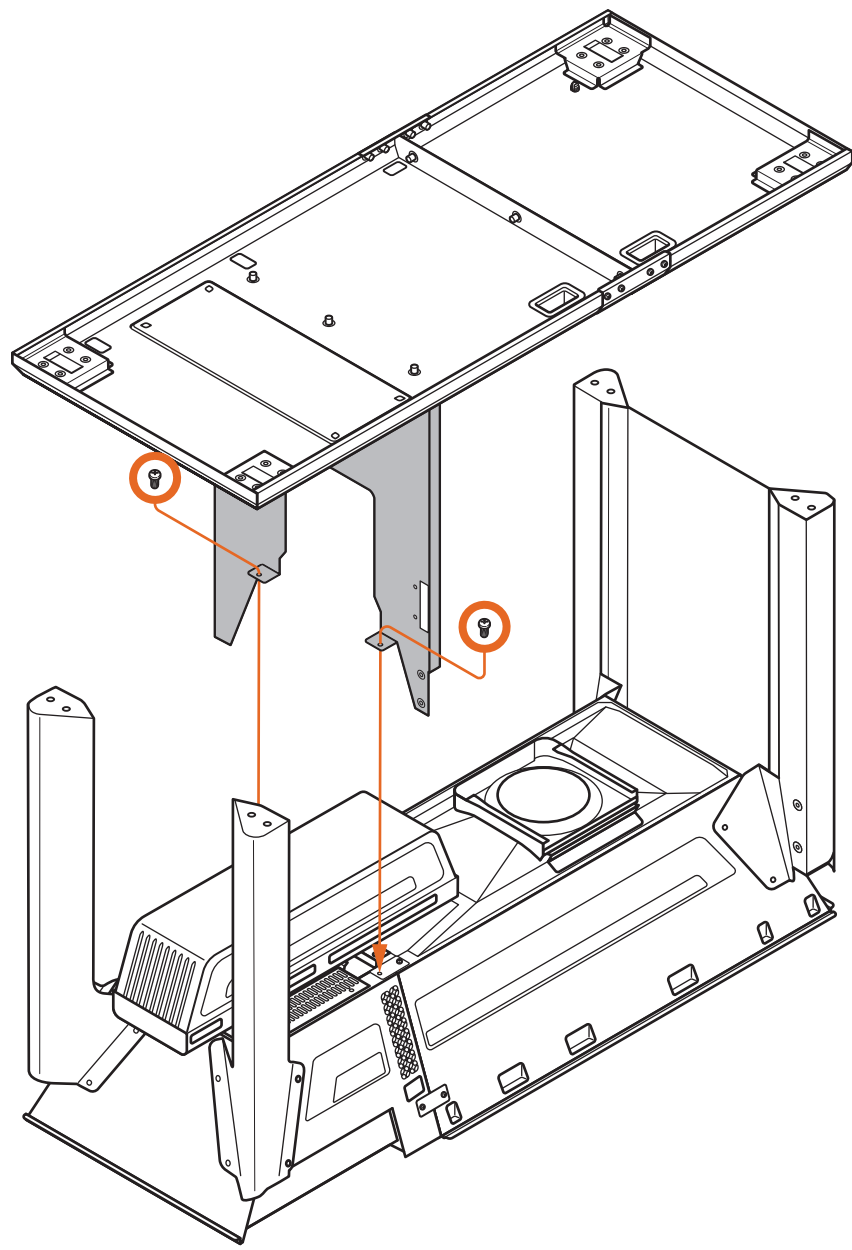
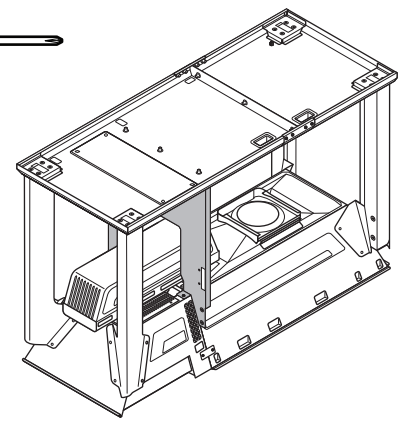

B





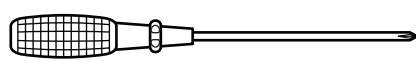

PROFI-TIPP: Für diesen Schritt werden andere Befestigungsteile benötigt!

4 ROLLEN ANBRINGEN

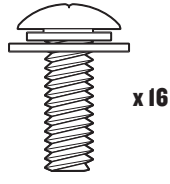

Verwenden Sie wieder **DIESE** Schraube!



A

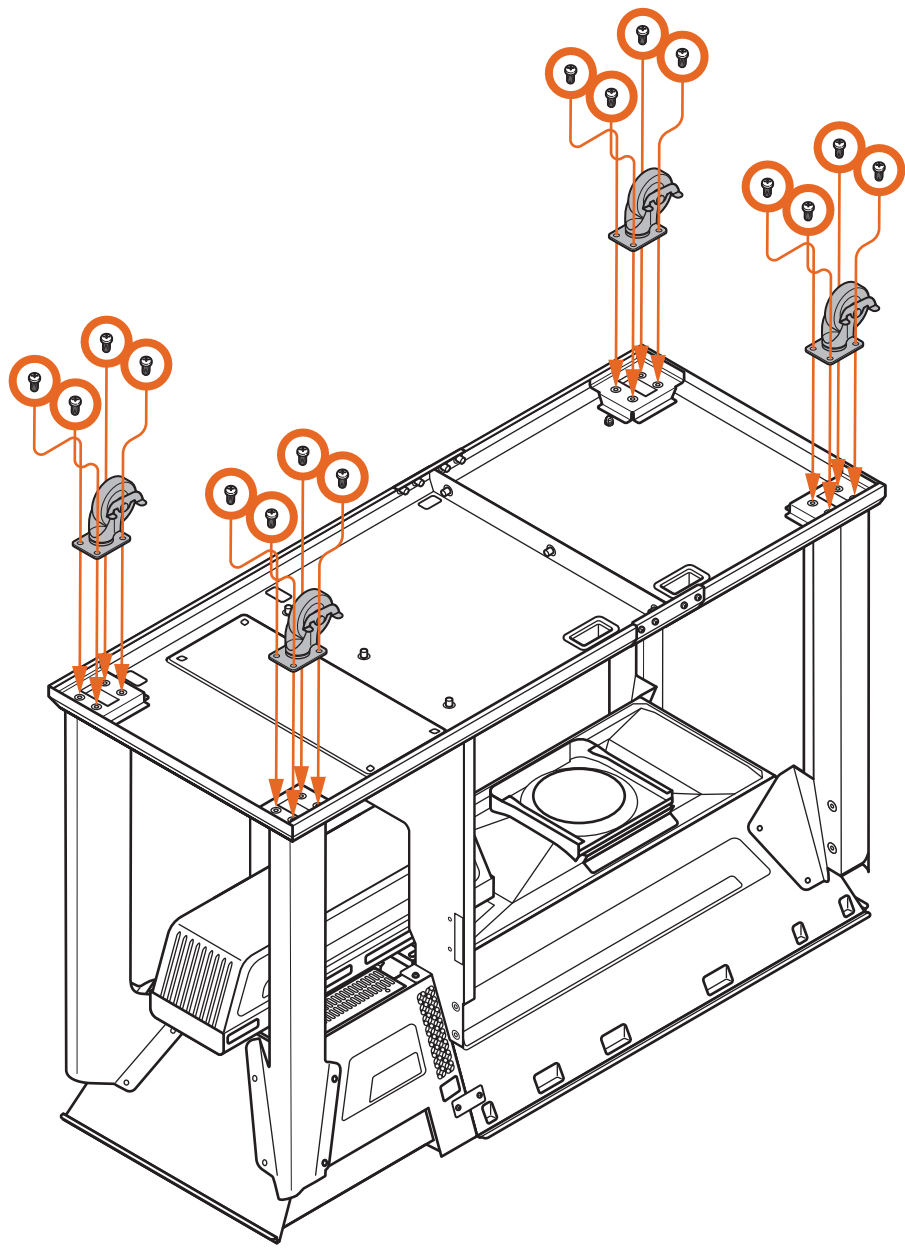
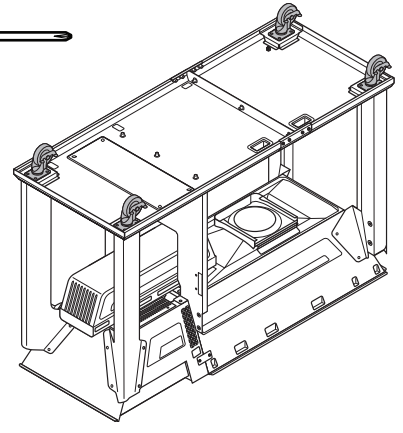



 **PROFI-TIPP:** Lassen Sie sich beim Anheben und Drehen des Grills von einer zweiten Person helfen.

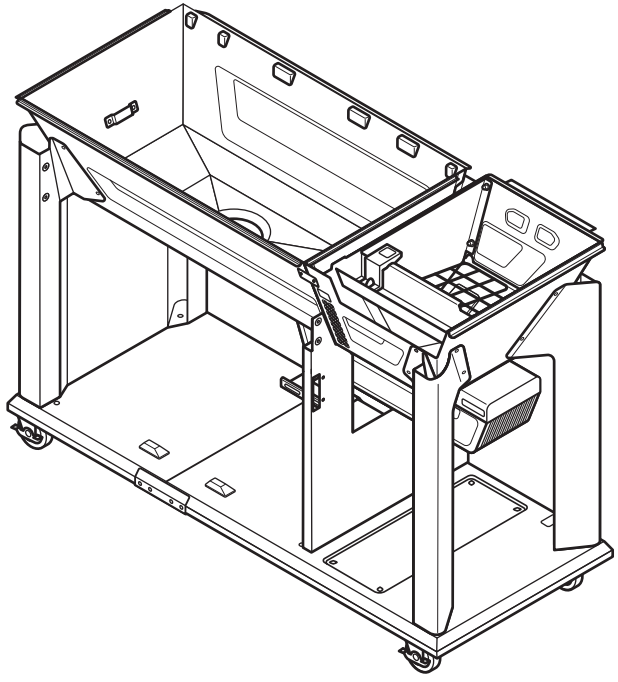
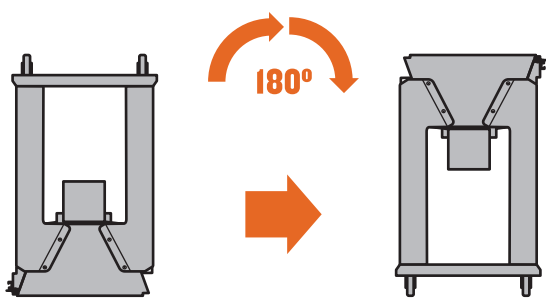
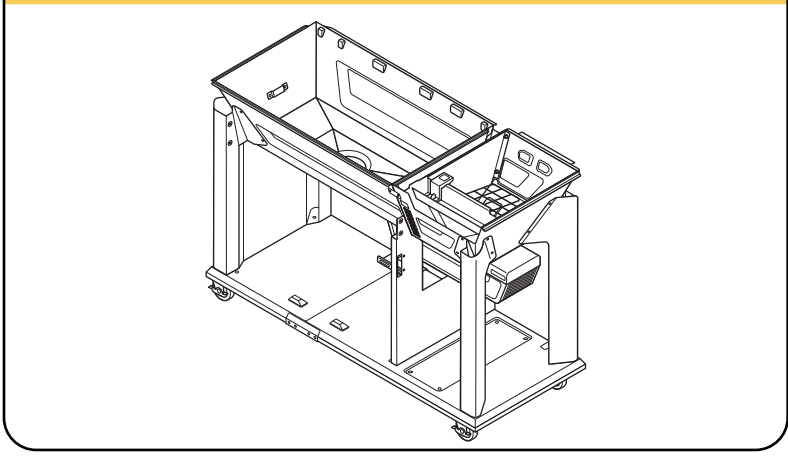

5 GRILL AUFRECHT DREHEN



 **PROFI-TIPP:** Stellen Sie die Rollen fest, um ein Wegrollen des Grills zu verhindern.



PROFI-TIPP: Wenn Sie bei diesem Schritt Hilfe benötigen, scannen Sie diesen QR-Code für unsere animierte Anleitung.

6 P.A.L.-MULTIFUNKTIONSHALTERUNG ANBRINGEN

**GUTE ARBEIT!
KAPITEL 2 ABGESCHLOSSEN!**

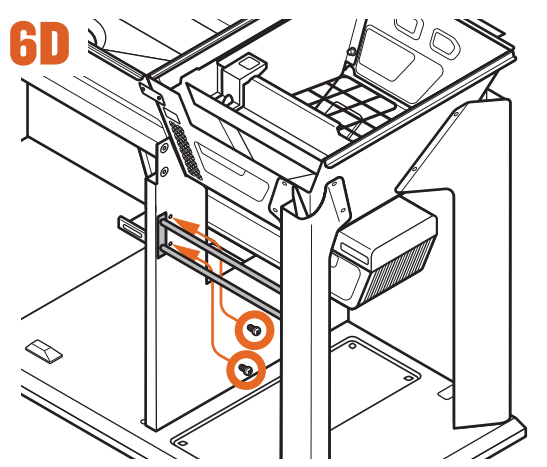
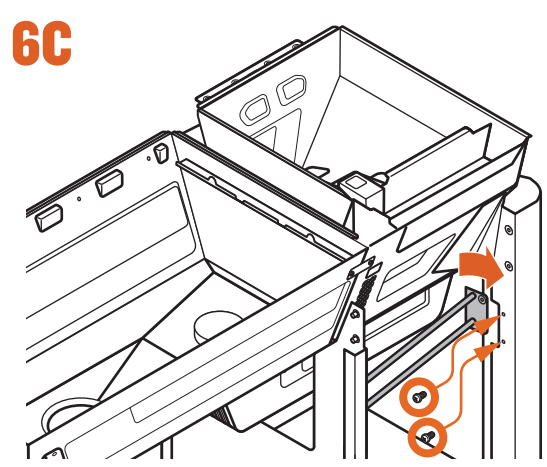
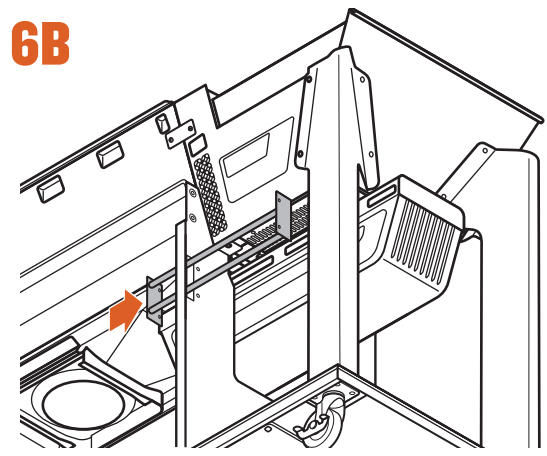
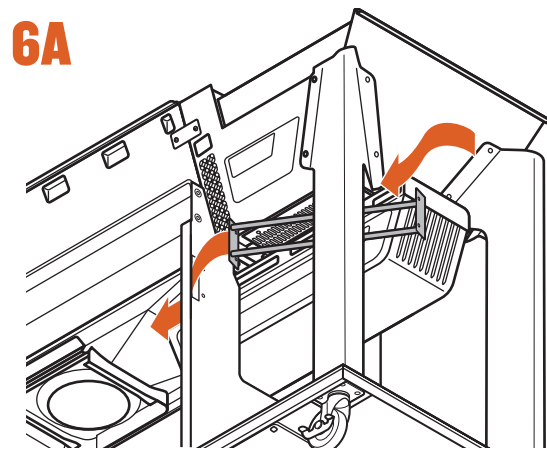
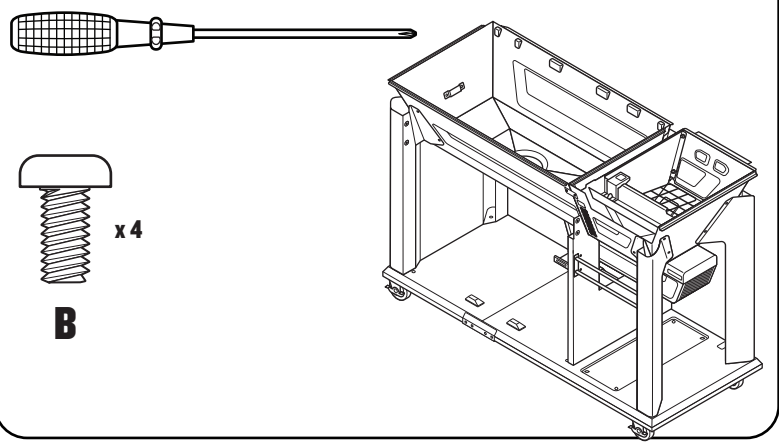

KAPITEL 3

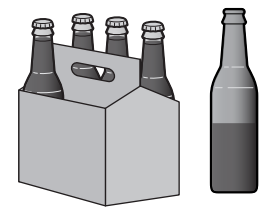

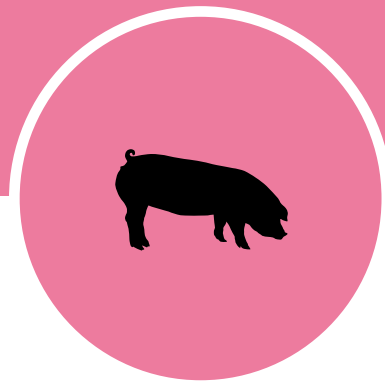
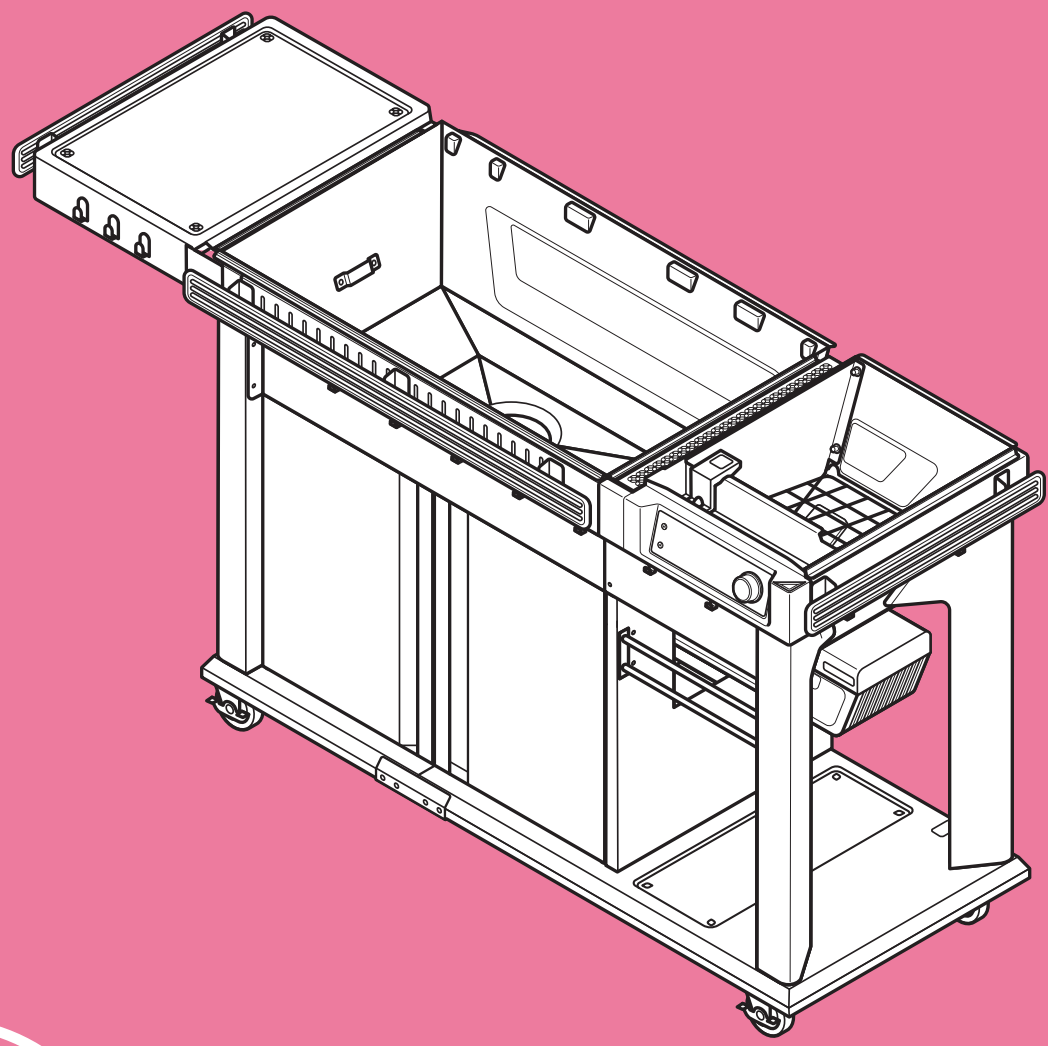
WEGKLAPPBARE SEITLICHE ABLAGE, BASIS UND BEDIENFELD

KAPITEL 3

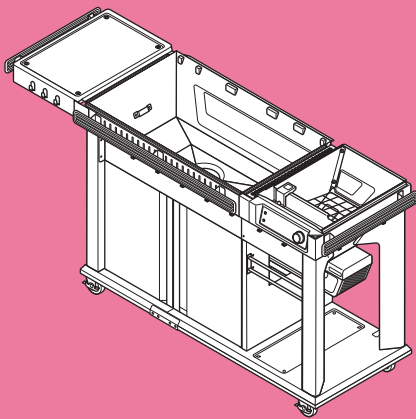

1 P.A.L.-SCHIENEN ZUSAMMENBAUEN

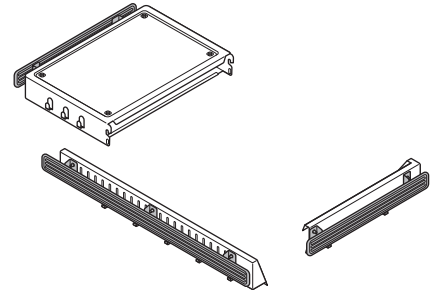
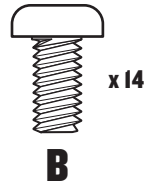
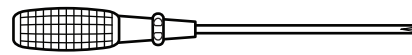

PROFI-TIPP: Ziehen Sie alle Schrauben zunächst handfest an und ziehen Sie sie dann mit einem Schraubendreher fest.

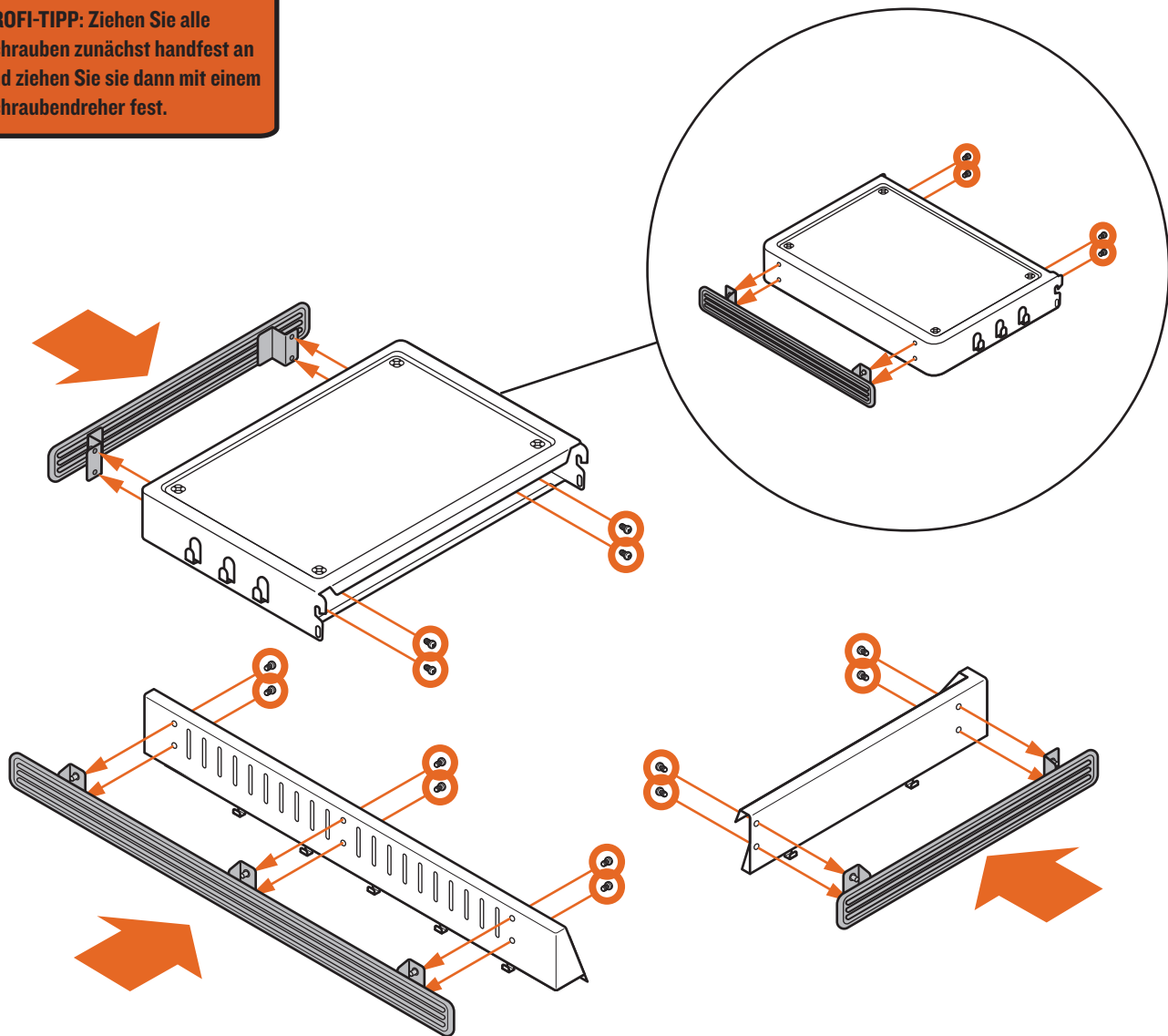



PROFI-TIPP: Dieser Schritt kann ein bisschen schwierig sein. Scannen Sie den QR-Code, um ein Video mit einer Animation zur Montage anzuzeigen. Gehen Sie für ein Video zu Kapitel 3, Schritt 2.



PROFI-TIPP: Um zu verhindern, dass Befestigungsteile in das Förderschneckengehäuse fallen, legen Sie dieses Handbuch auf den Rost.

2 P.A.L.-VERKLEIDUNGEN ANBRINGEN

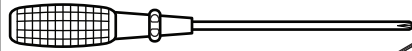

x 6

B

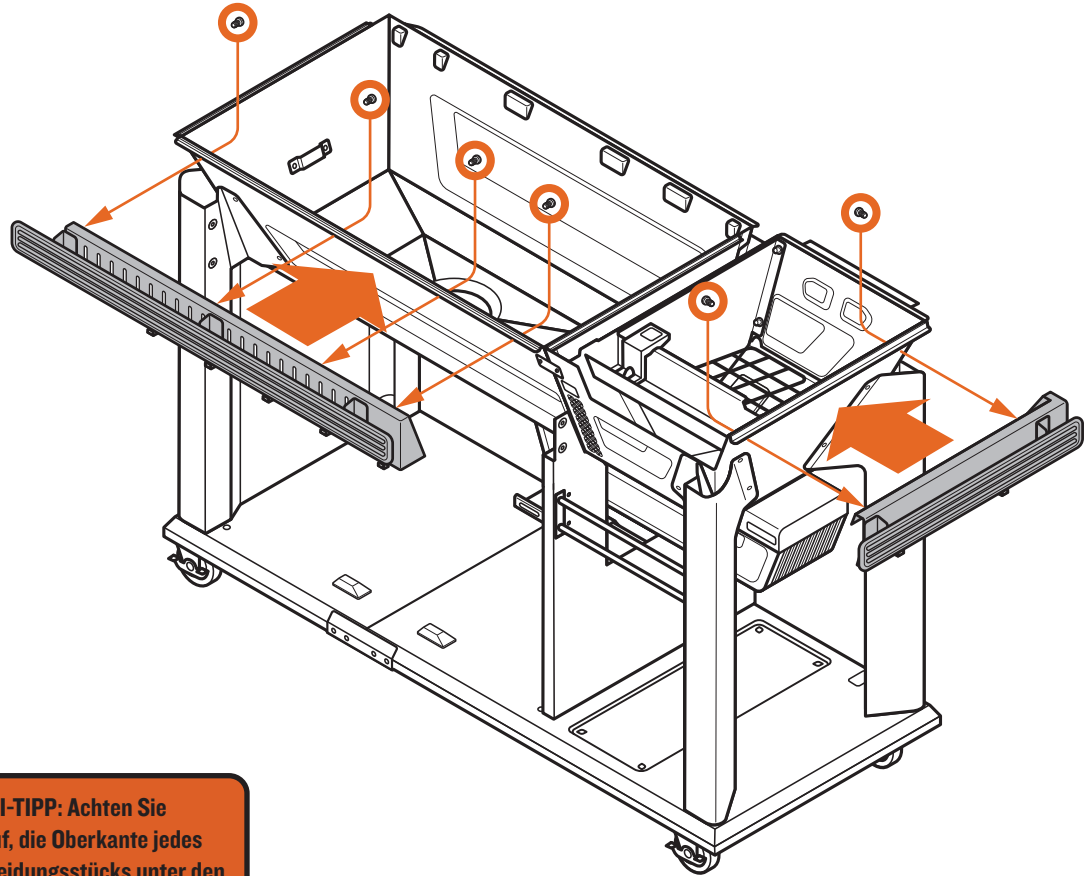
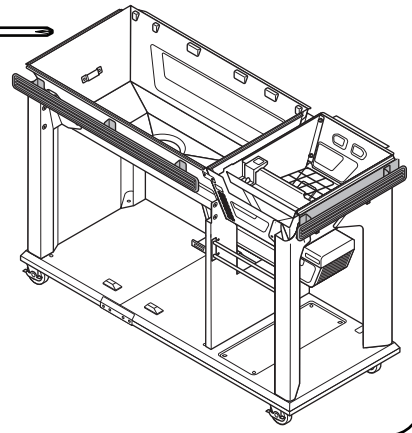

PROFI-TIPP: Achten Sie darauf, die Oberkante jedes Verkleidungsstücks unter den Flansch am Grill zu schieben.

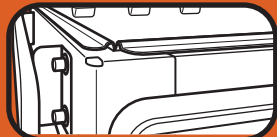



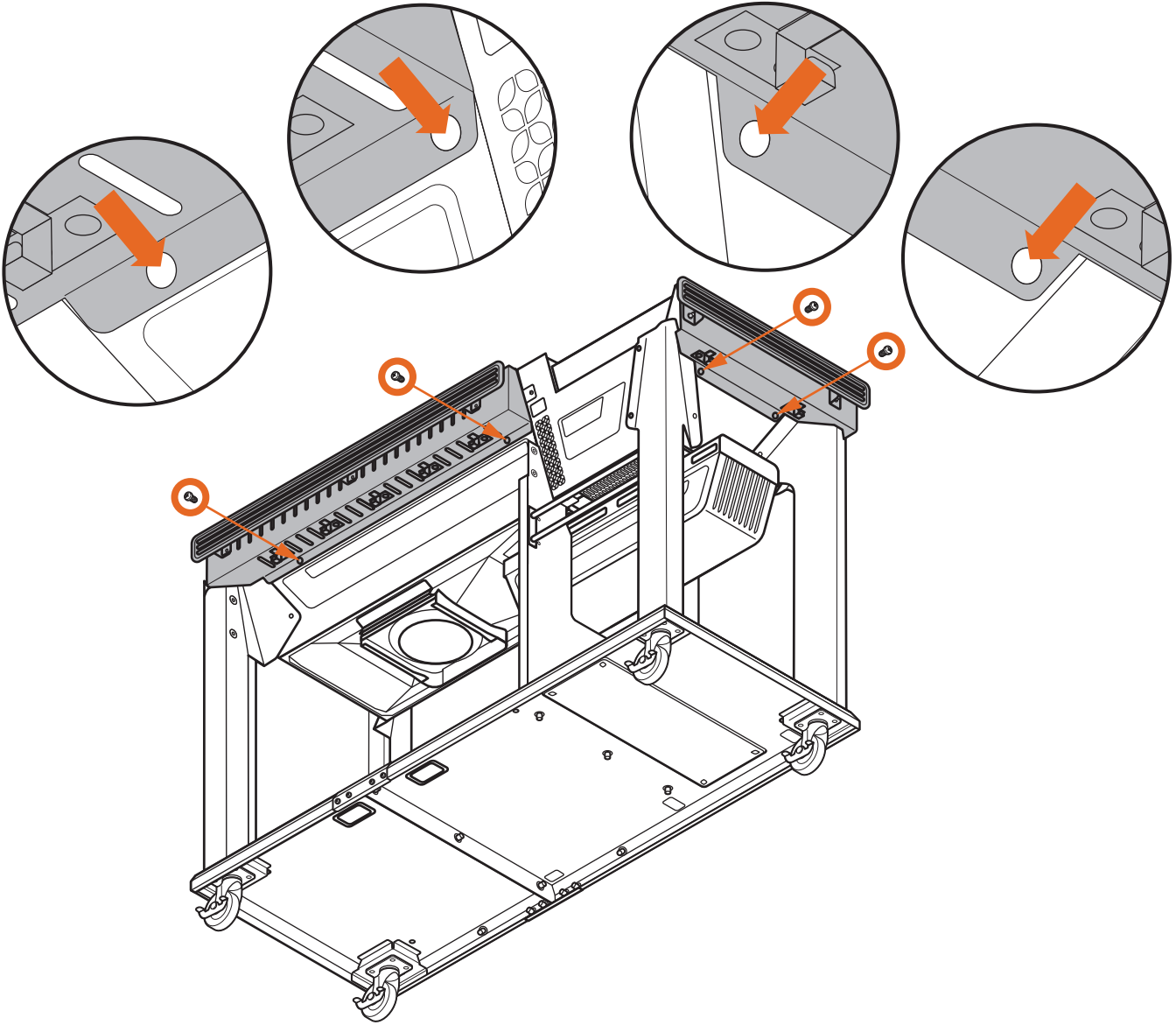
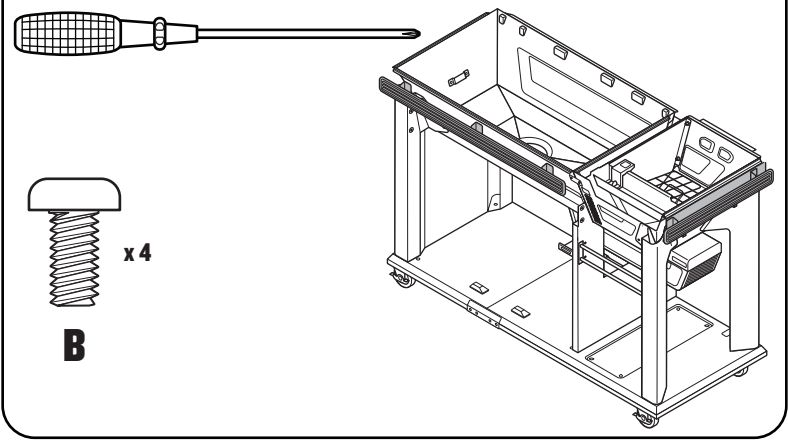

3 P.A.L.-VERKLEIDUNGEN BEFESTIGEN



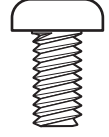
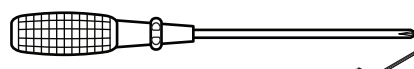

4A WEGKLAPPBARE SEITLICHE ABLAGE ANBRINGEN



x5

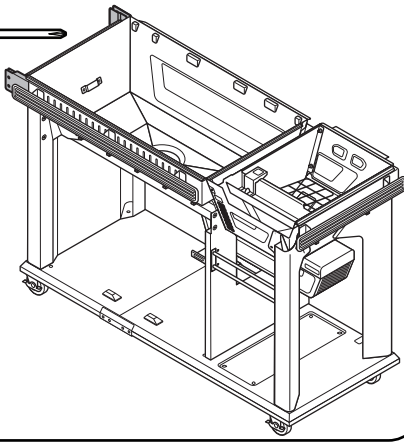
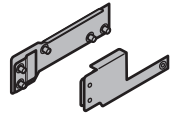

B

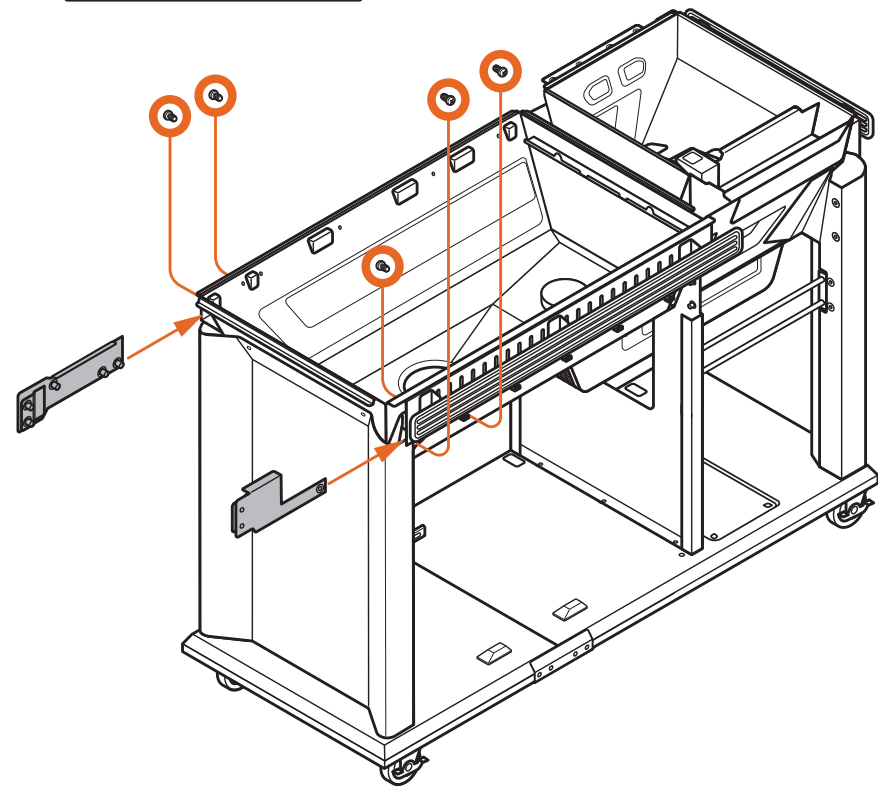
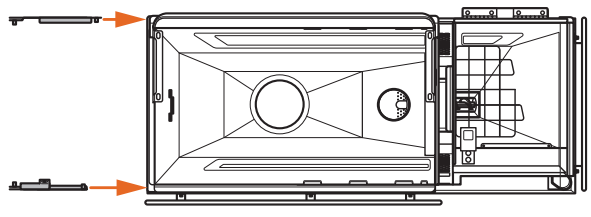

PROFI-TIPP: Ziehen Sie alle Schrauben zunächst handfest an und ziehen Sie sie dann mit einem Schraubendreher fest.

4B WEGKLAPPBARE SEITLICHE ABLAGE ANBRINGEN



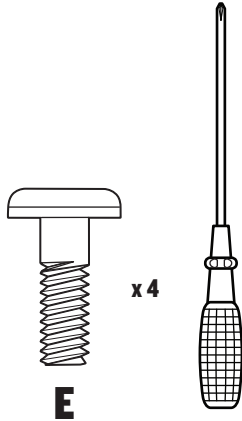
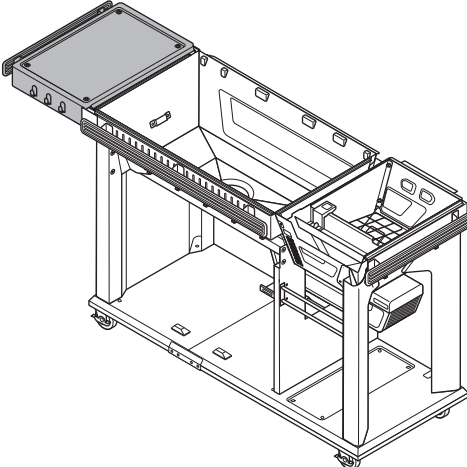
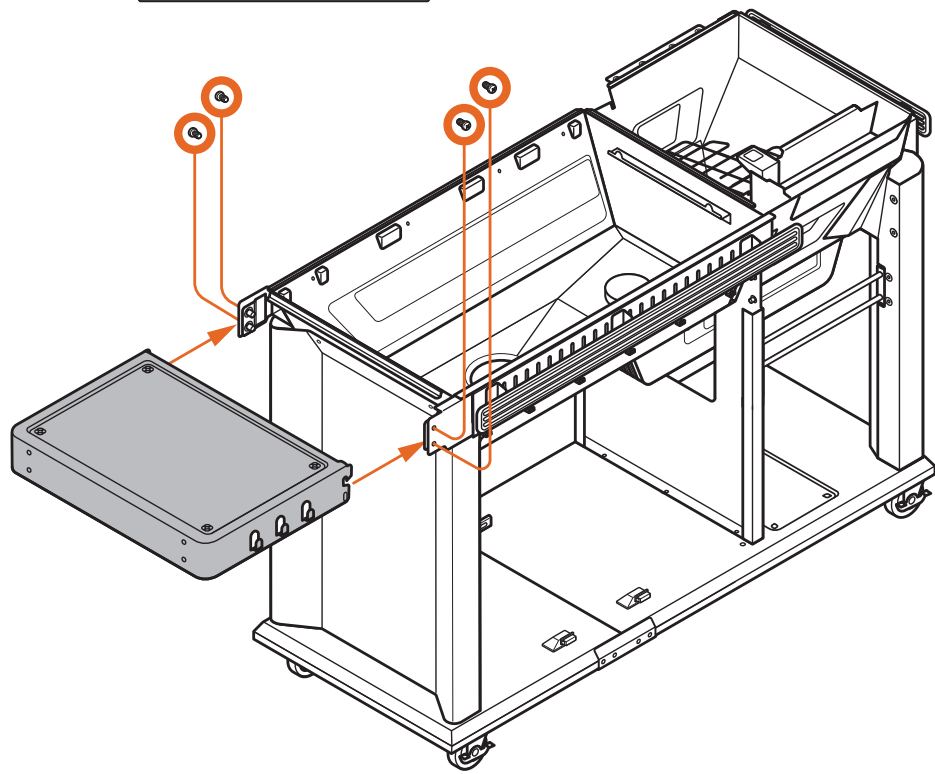
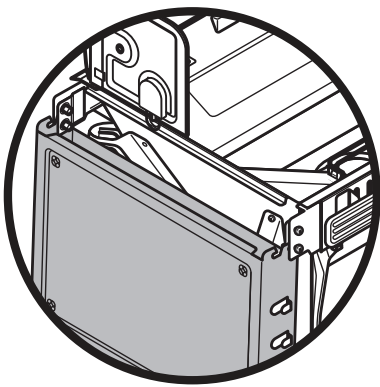
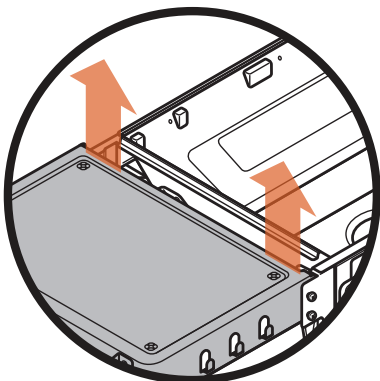
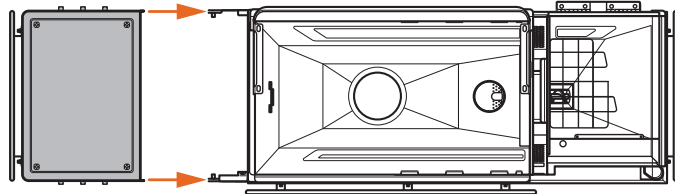





PROFI-TIPP: Lassen Sie sich bei der Positionierung der Rückwandplatten von einer zweiten Person helfen.

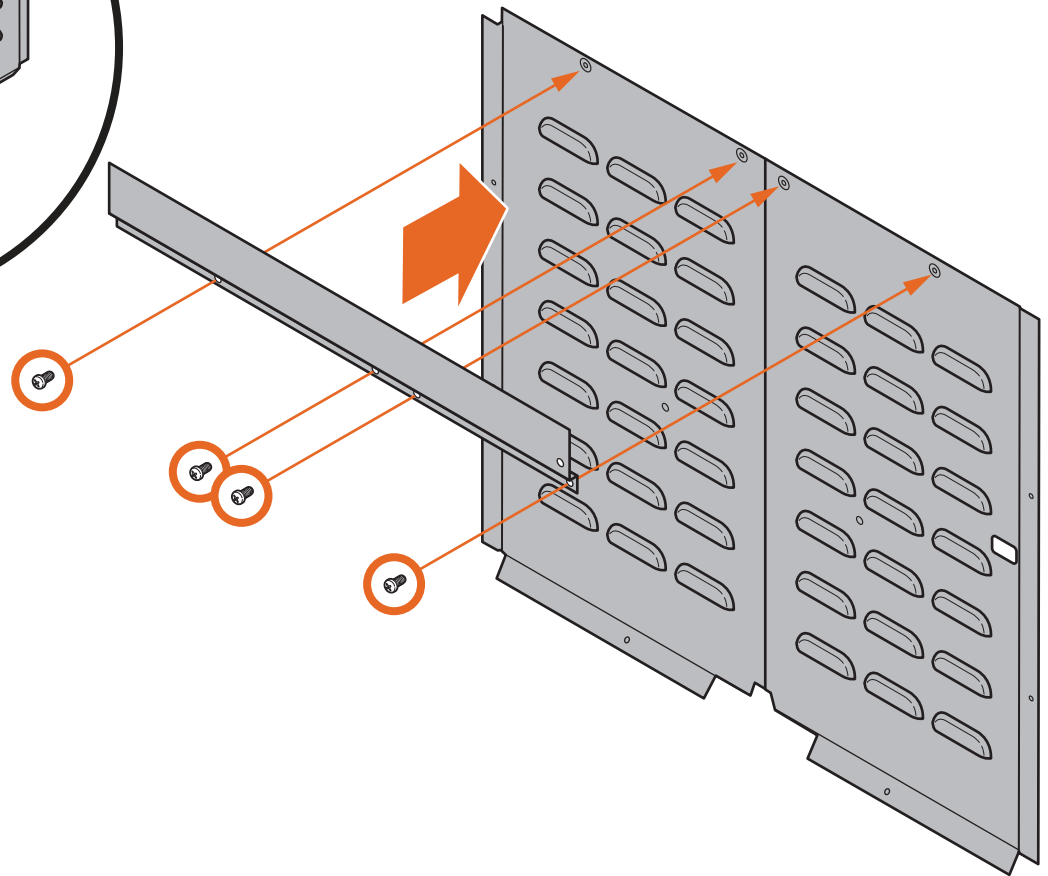
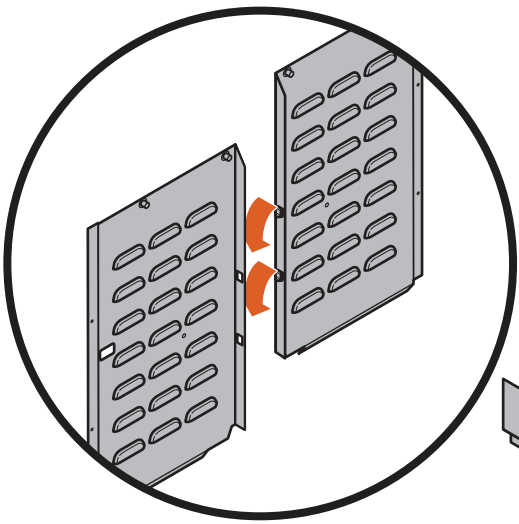
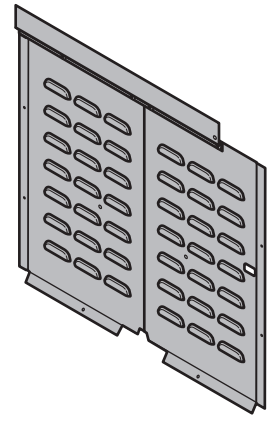
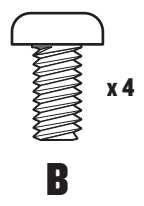

5 RÜCKWANDPLATTEN UND OBERE VERKLEIDUNG MONTIEREN





6 HINTERE OBERE VERKLEIDUNG ANBRINGEN/RÜCKWANDMONTAGE

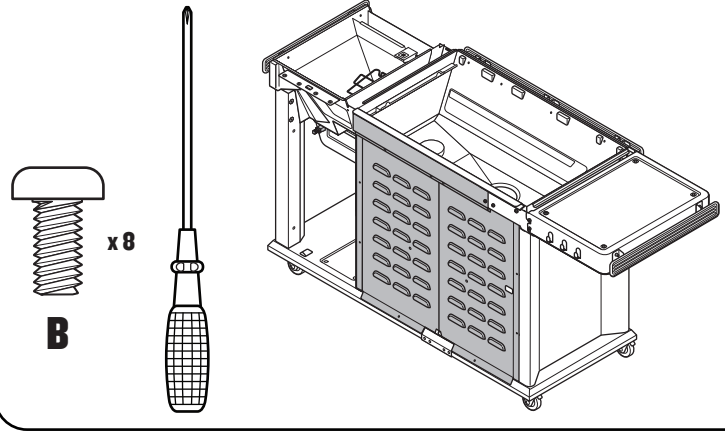

PROFI-TIPP: Die seitliche Schraube zuletzt montieren und dabei die Rückwand nach oben drücken.

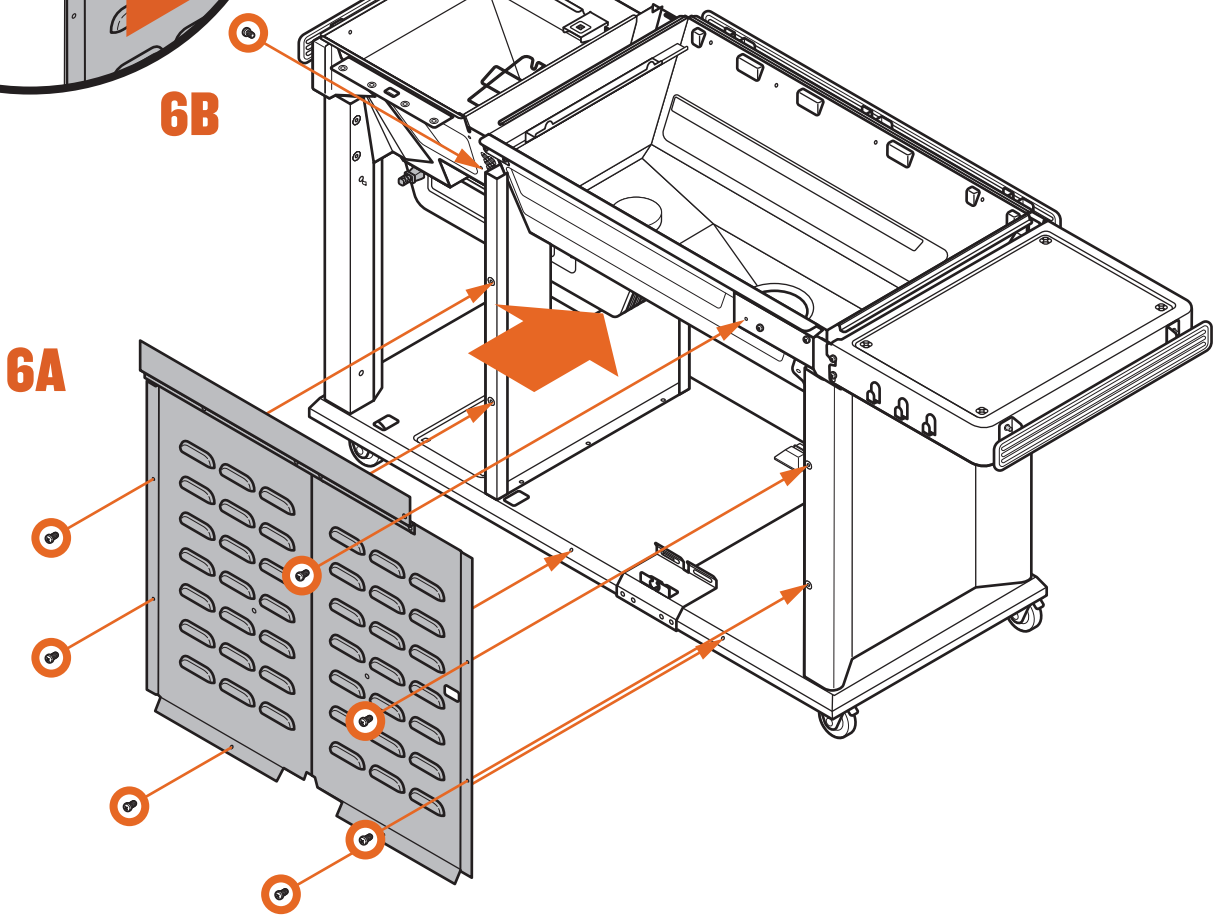



 **PROFI-TIPP:** Für diesen Schritt sind keine Befestigungsteile erforderlich.

7 RÜCKWAND MONTIEREN

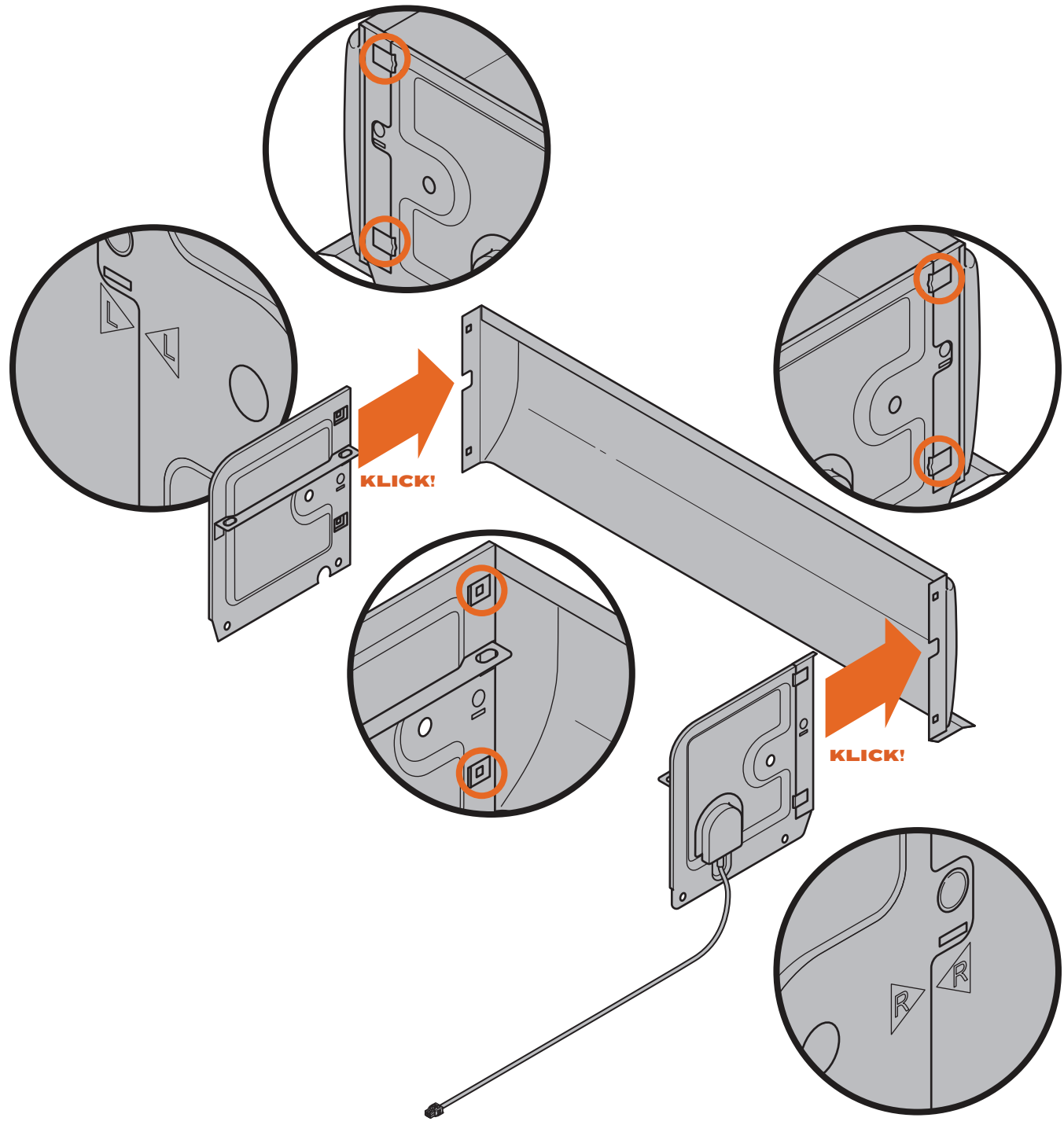
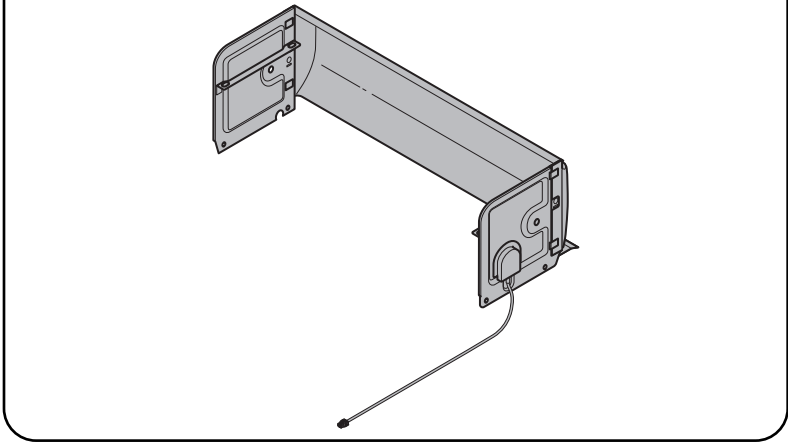



PROFI-TIPP: Achten Sie darauf, dass das Kabel nicht zwischen Rückwand und Grillgehäuse eingeklemmt wird! Führen Sie das Kabel außerdem vorsichtig durch die Öffnungen, um Beschädigungen zu vermeiden!

8 RÜCKWANDKABEL VERLEGEN

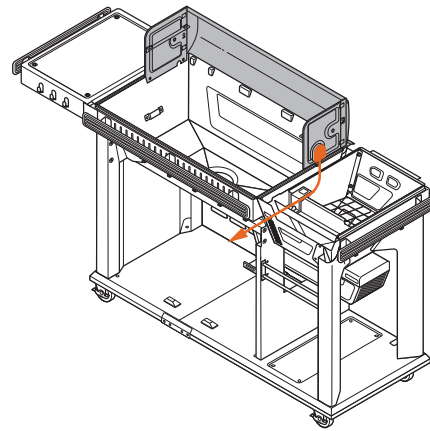

8A

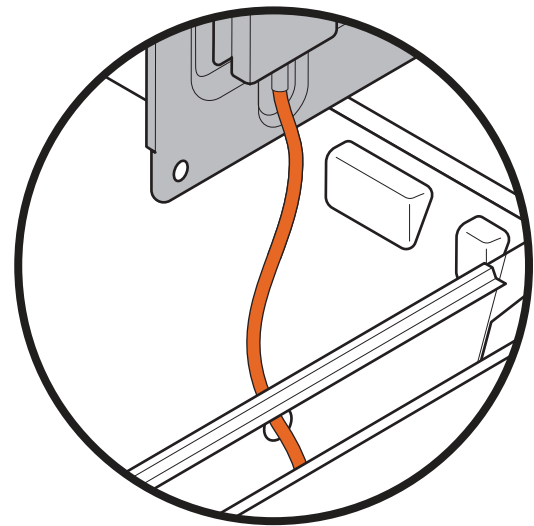
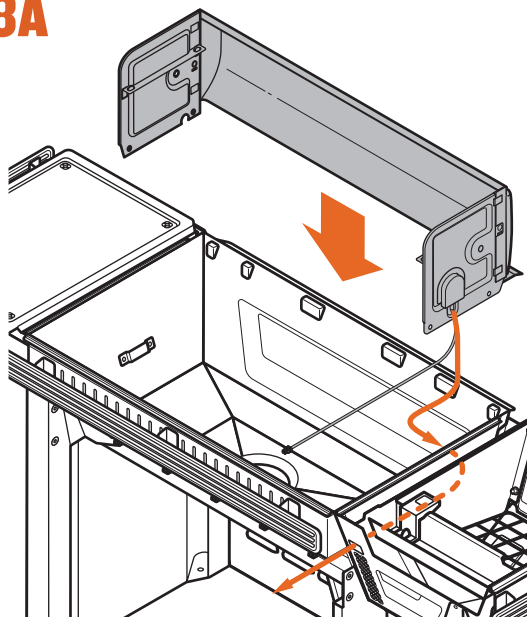

8B

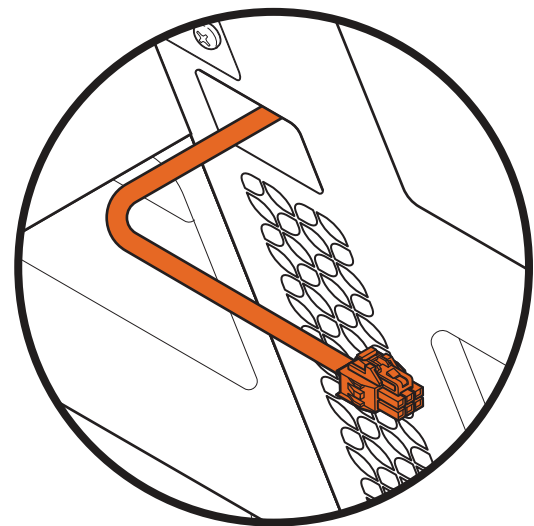
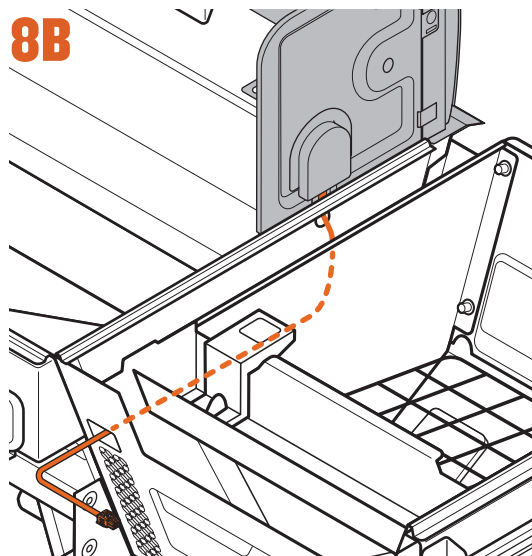



9 RÜCKWAND ANBRINGEN

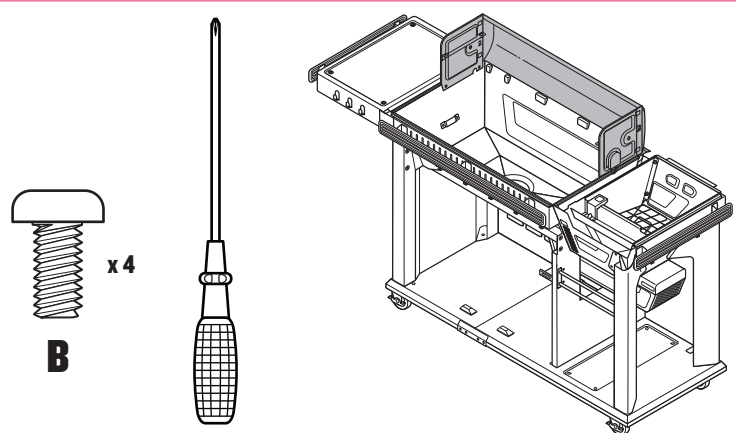

B x4

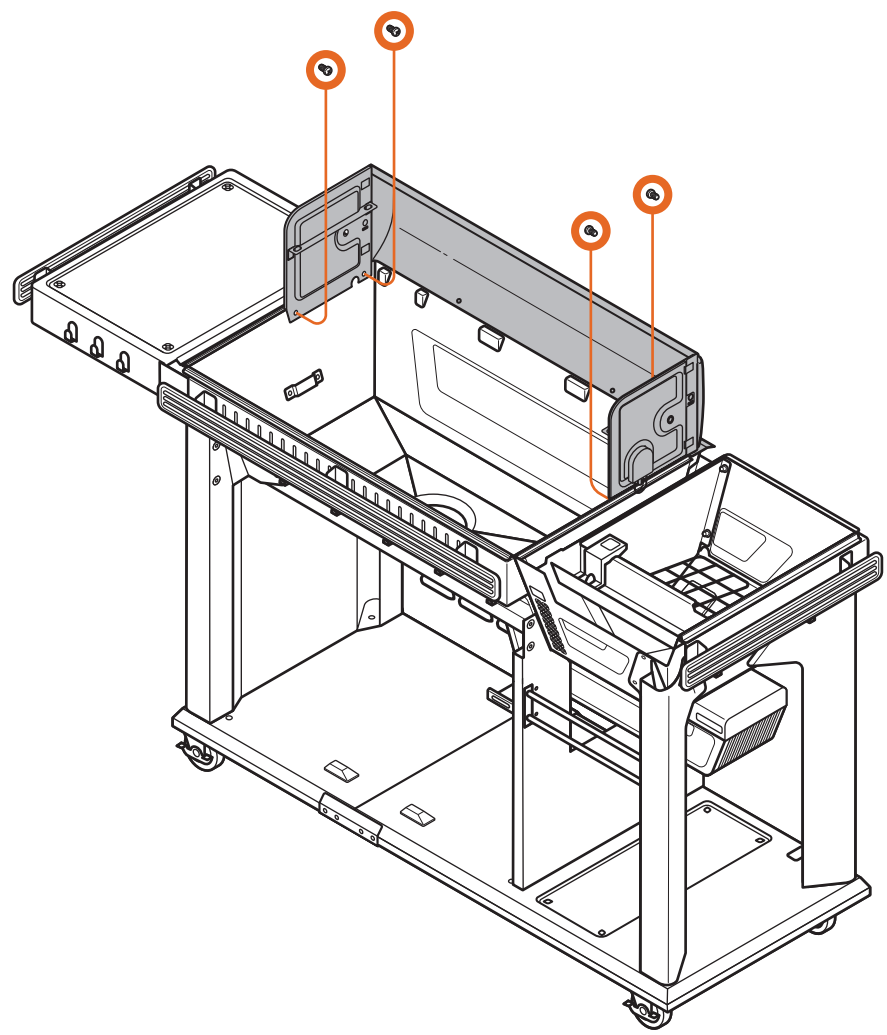



10 RÜCKSEITIGE HAKENLEISTE BEFESTIGEN

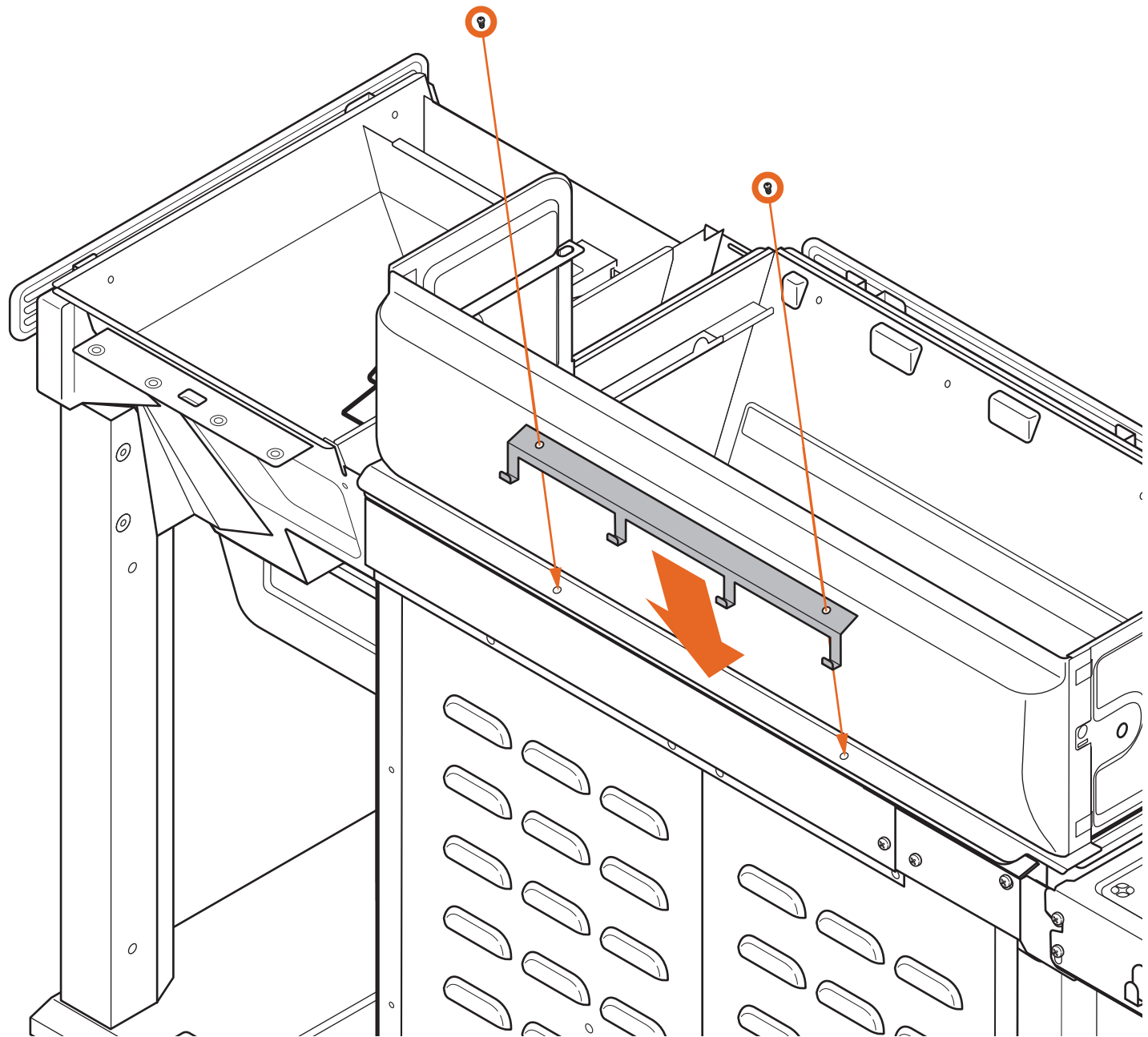
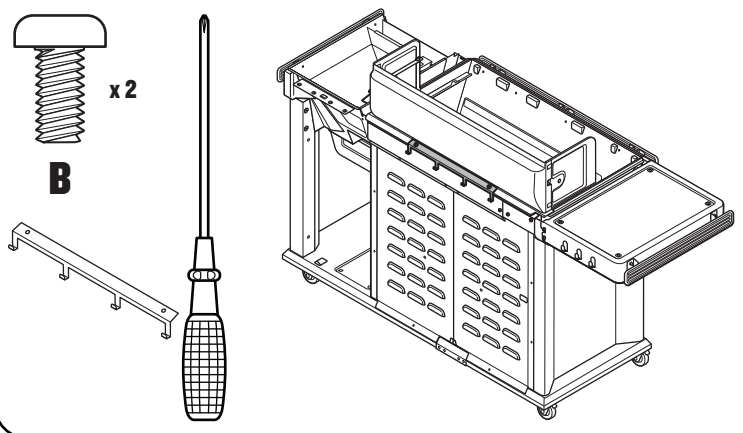





4-POLIGER STECKER DES WIDERSTANDSTEMPERATURFÜHLERS

12-POLIGER STECKER DES BEDIENFELDS

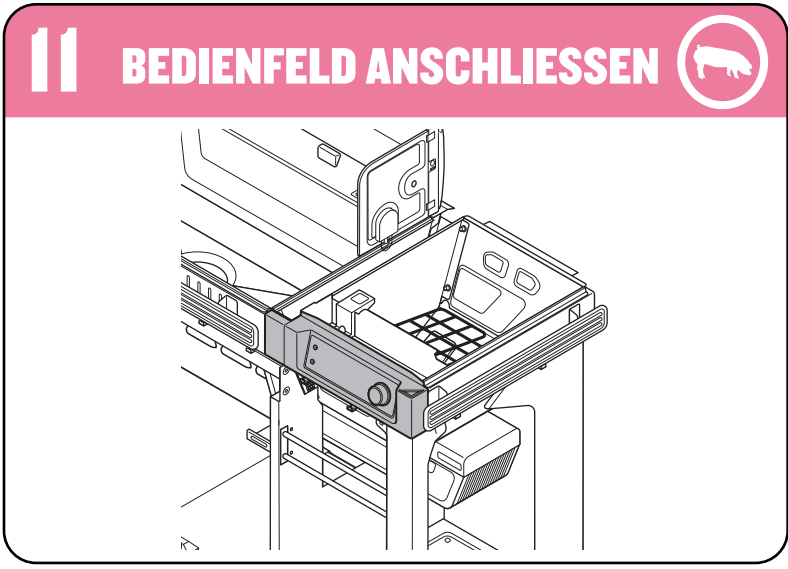
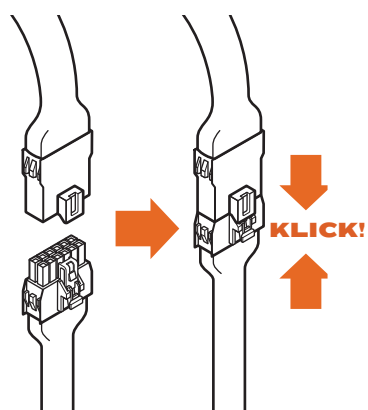
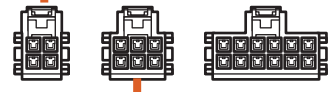
6-POLIGER STECKER DES PELLET-FÜLLSTANDSSENSORS

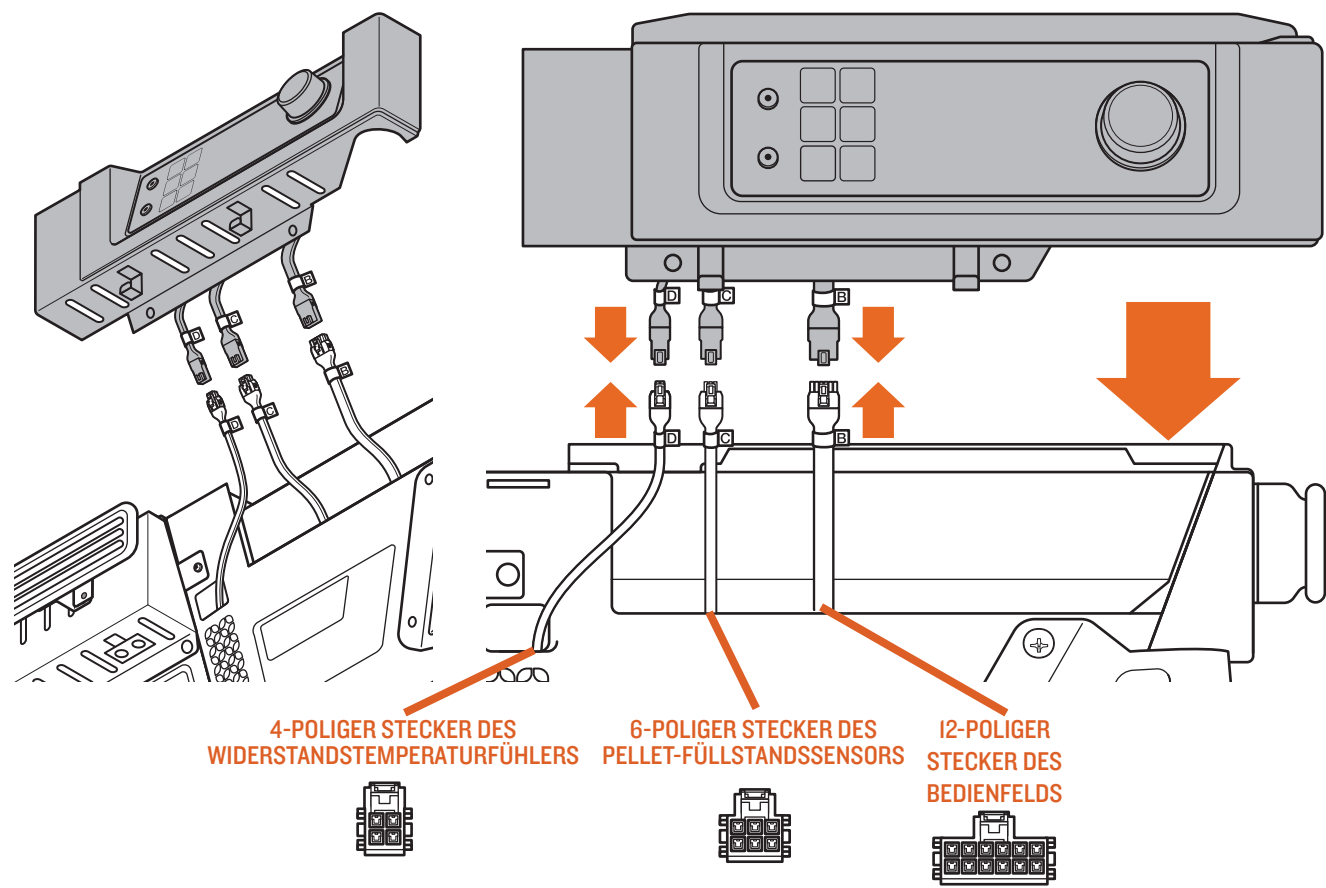

PROFI-TIPP: Zum einfacheren Anschließen legen Sie das Bedienfeld mit der Rückseite nach unten auf den Rand der Pelletkammer.

PROFI-TIPP: Stecken Sie die Kabel nach dem Anschließen wieder in den Grill, um ein Einklemmen zu verhindern.



12A BEDIENFELD ANBRINGEN

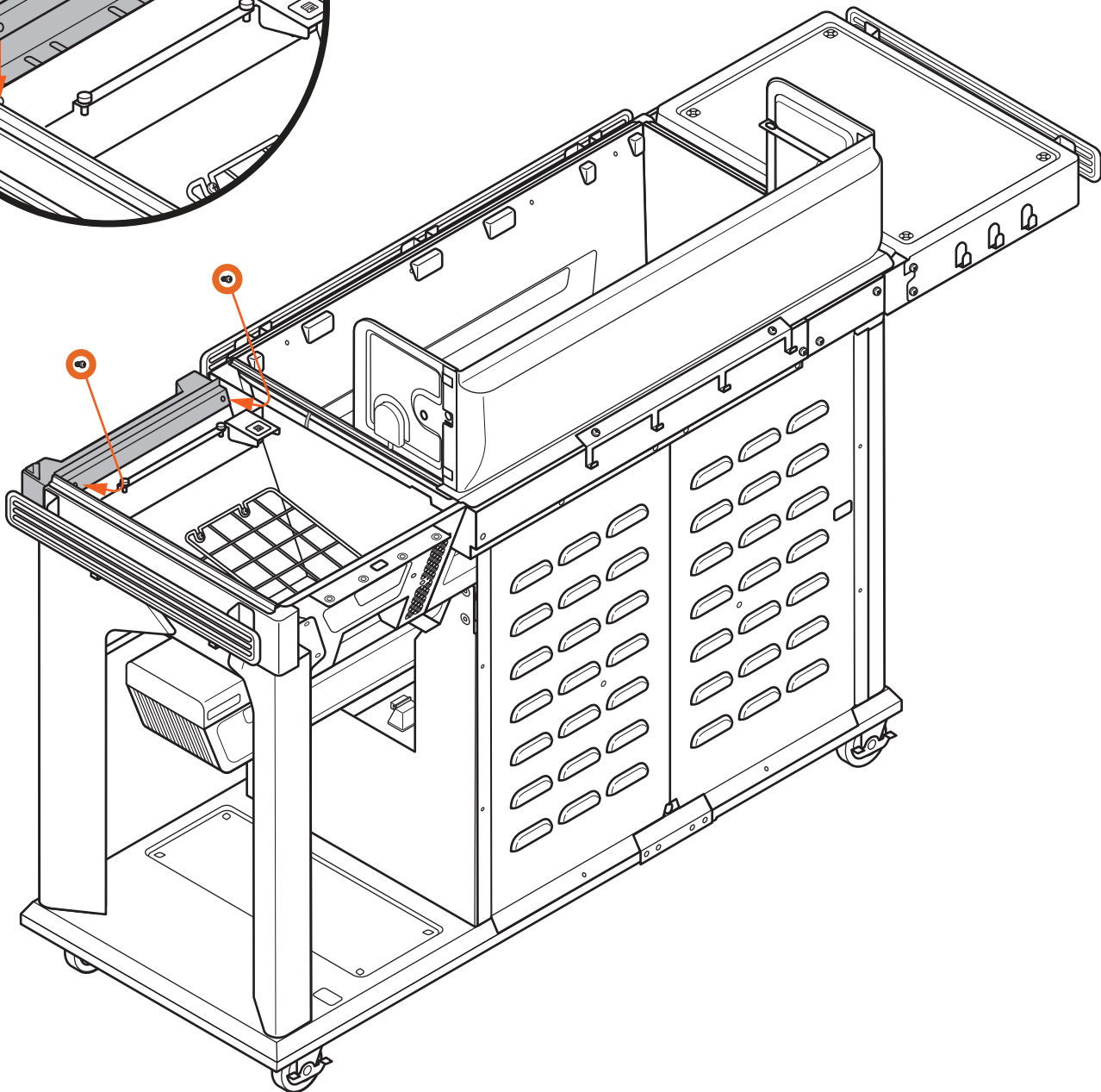
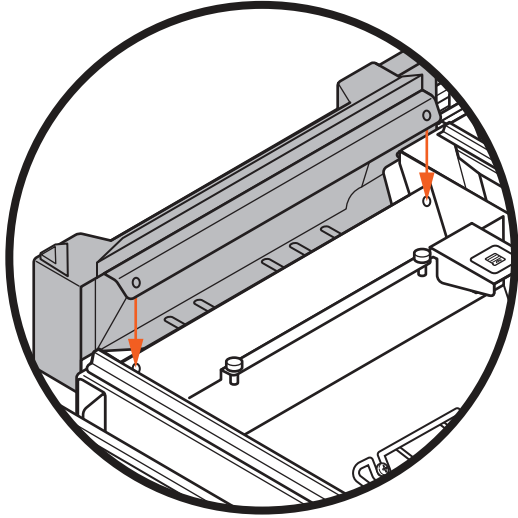
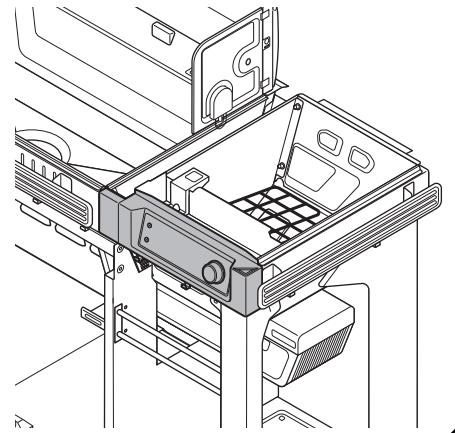
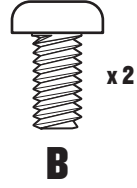

12B BEDIENFELD ANBRINGEN

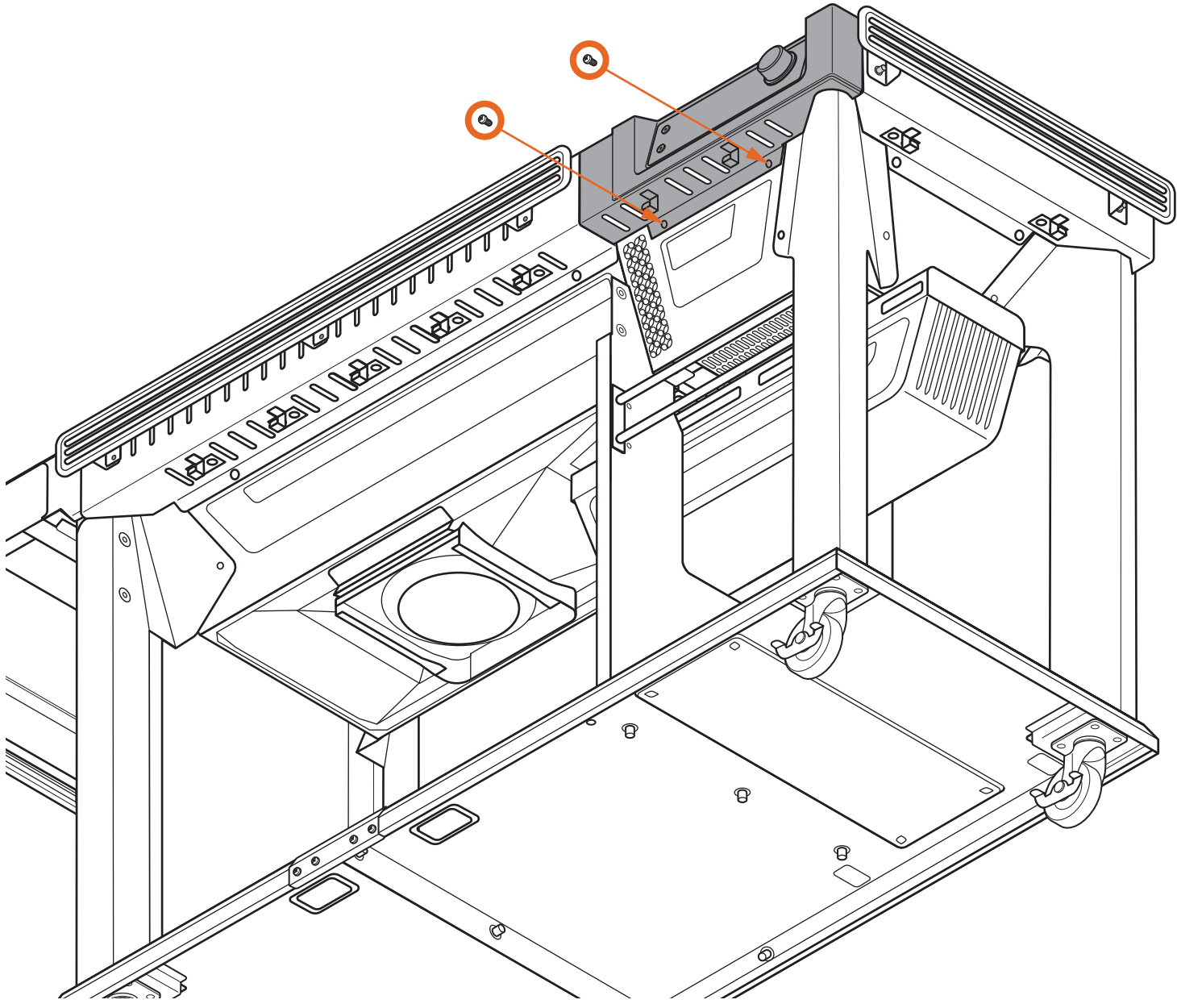
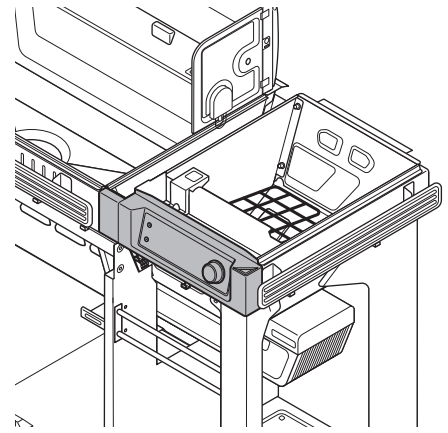
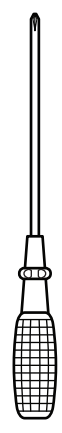
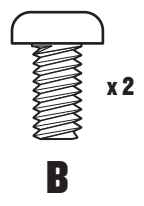



13 VORDERE VERKLEIDUNG ANBRINGEN

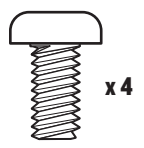
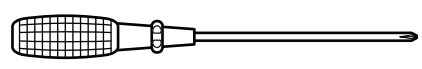

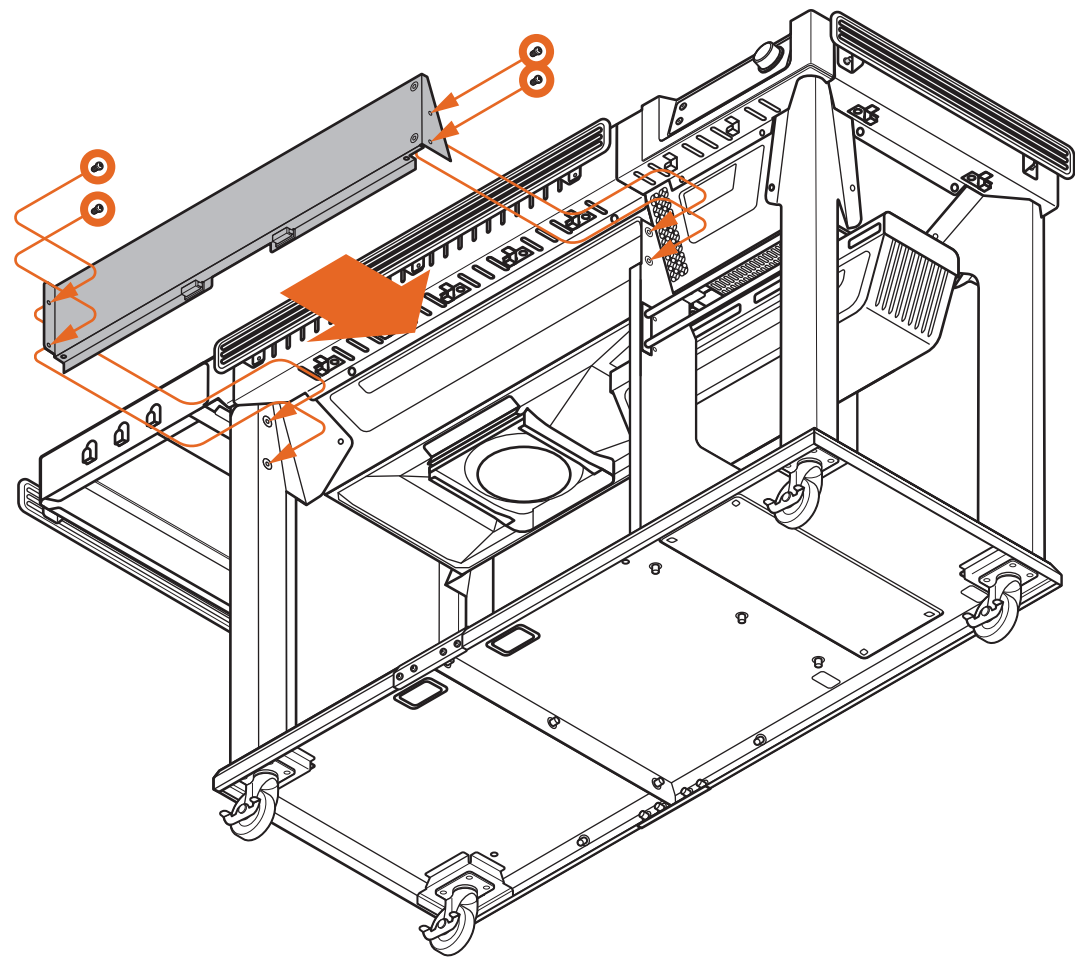
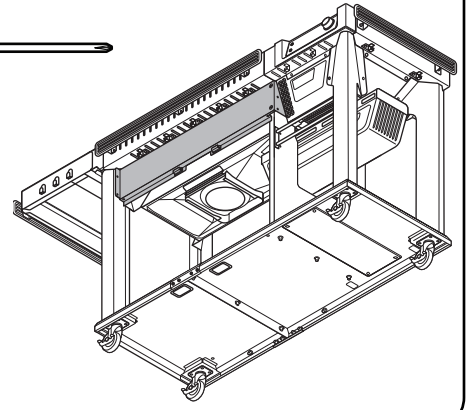

B



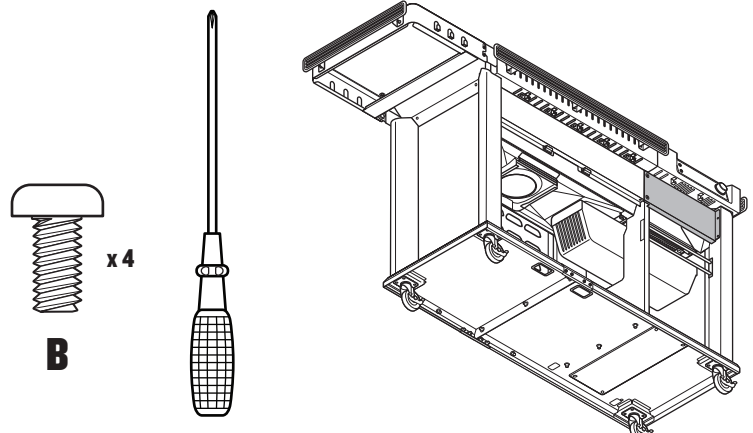

14 VORDERE RECHTE VERKLEIDUNG ANBRINGEN



B x4

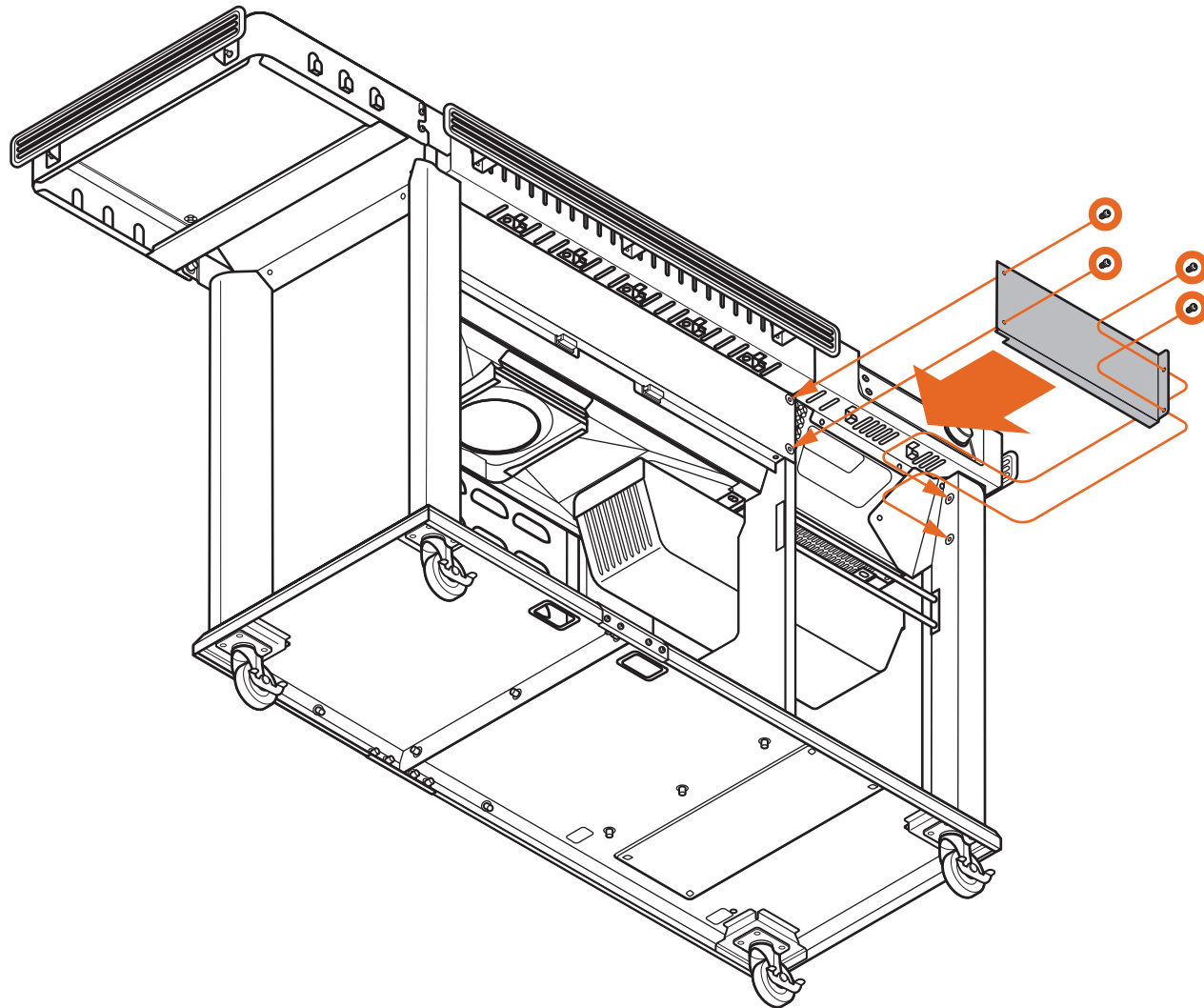



15 SCHRANKTÜREN ANBRINGEN

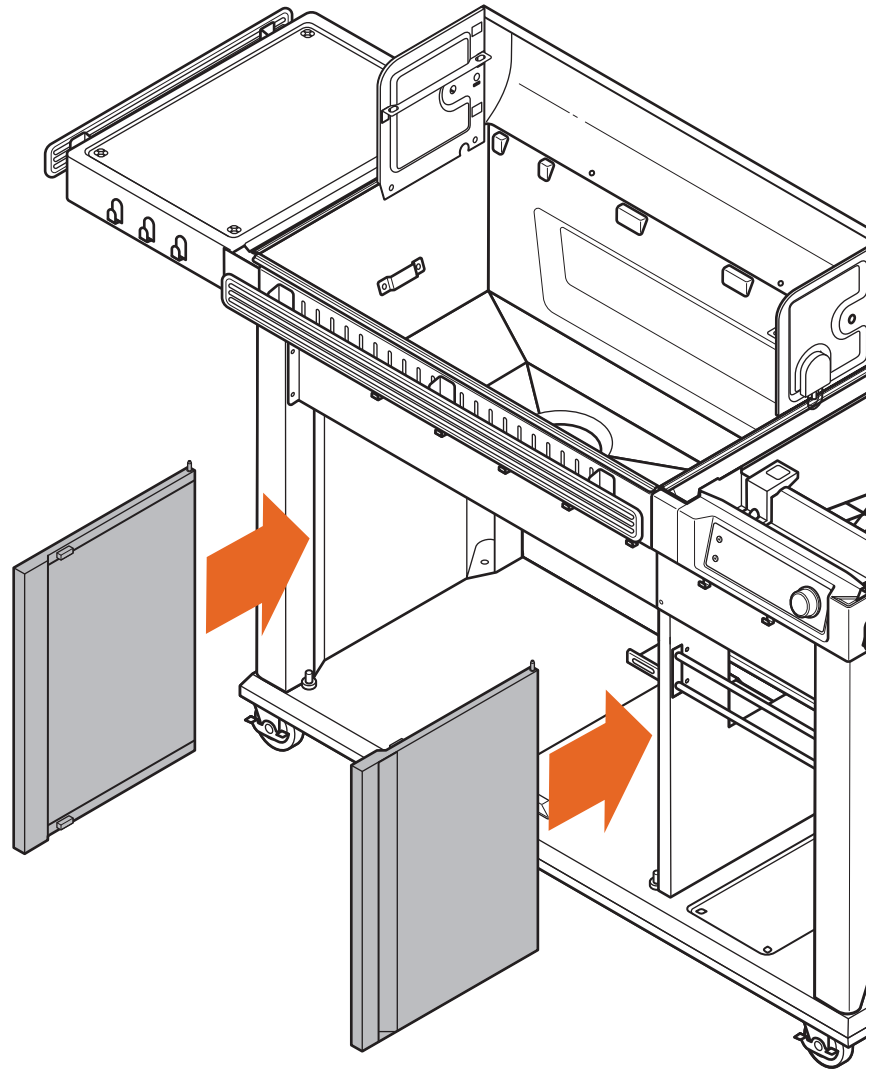
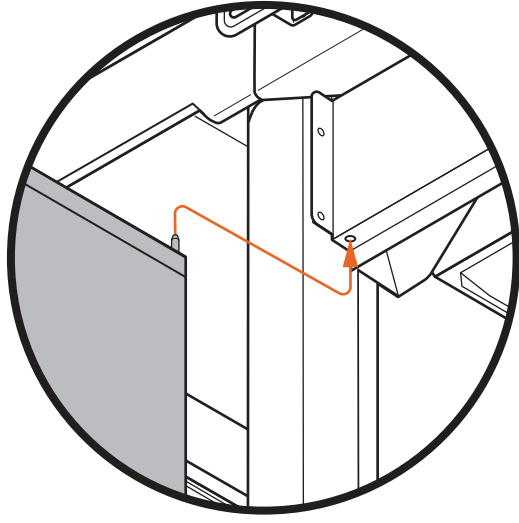
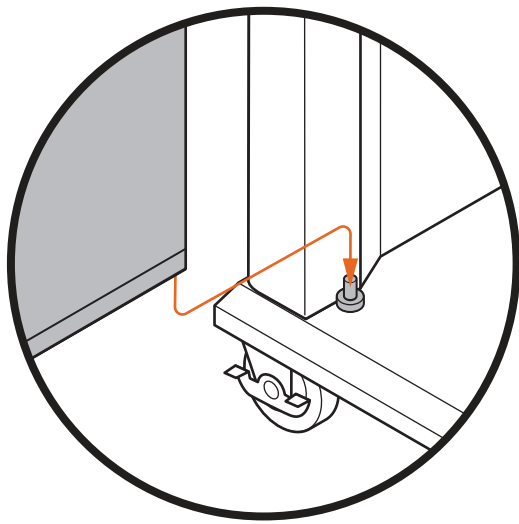
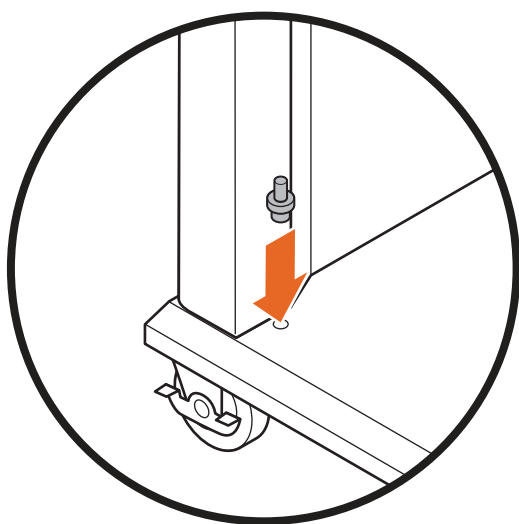
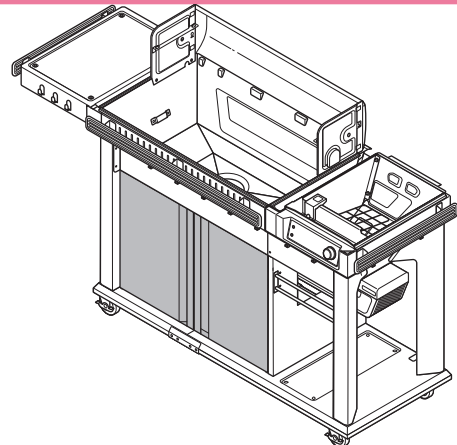
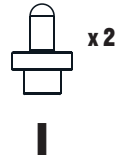



16 VERKLEIDUNGSLEISTE ANBRINGEN

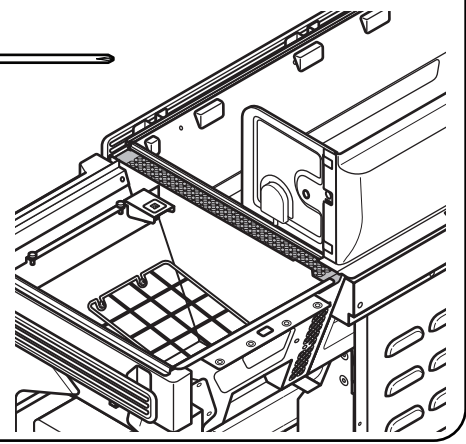
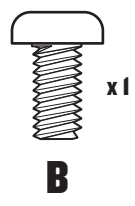
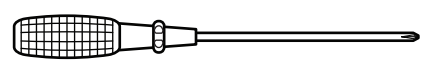

16A

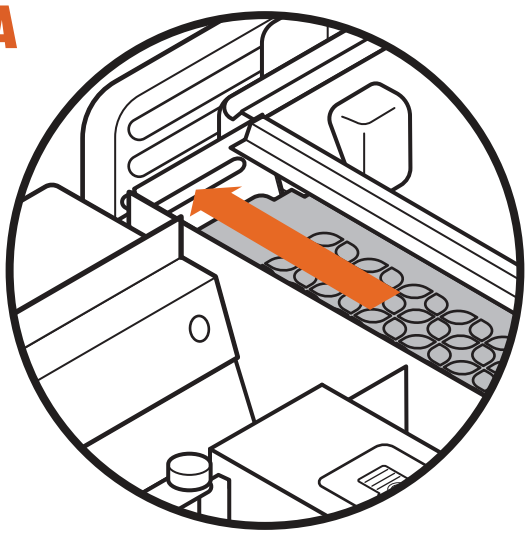

16B

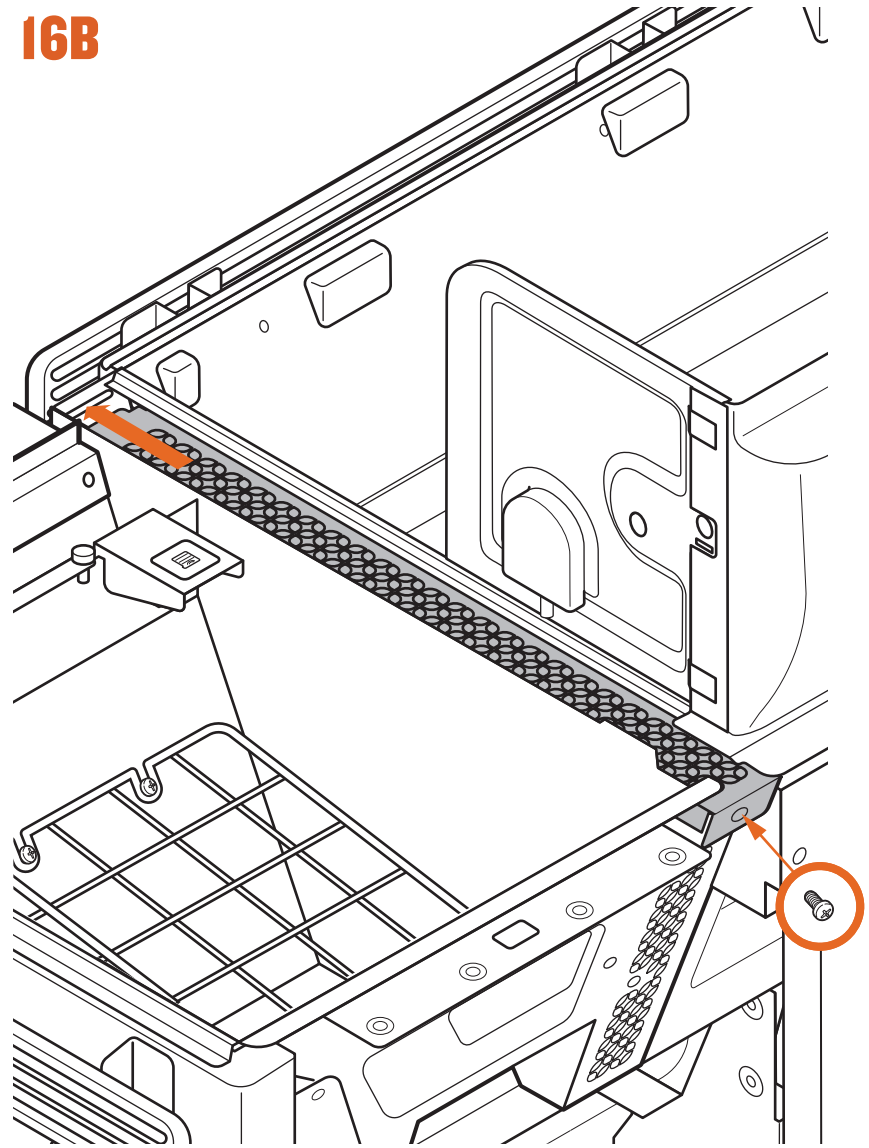

**GUTE ARBEIT!
KAPITEL 3 ABGESCHLOSSEN!**

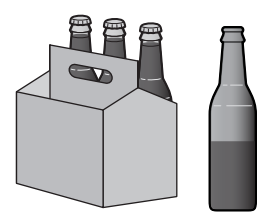

KAPITEL 4

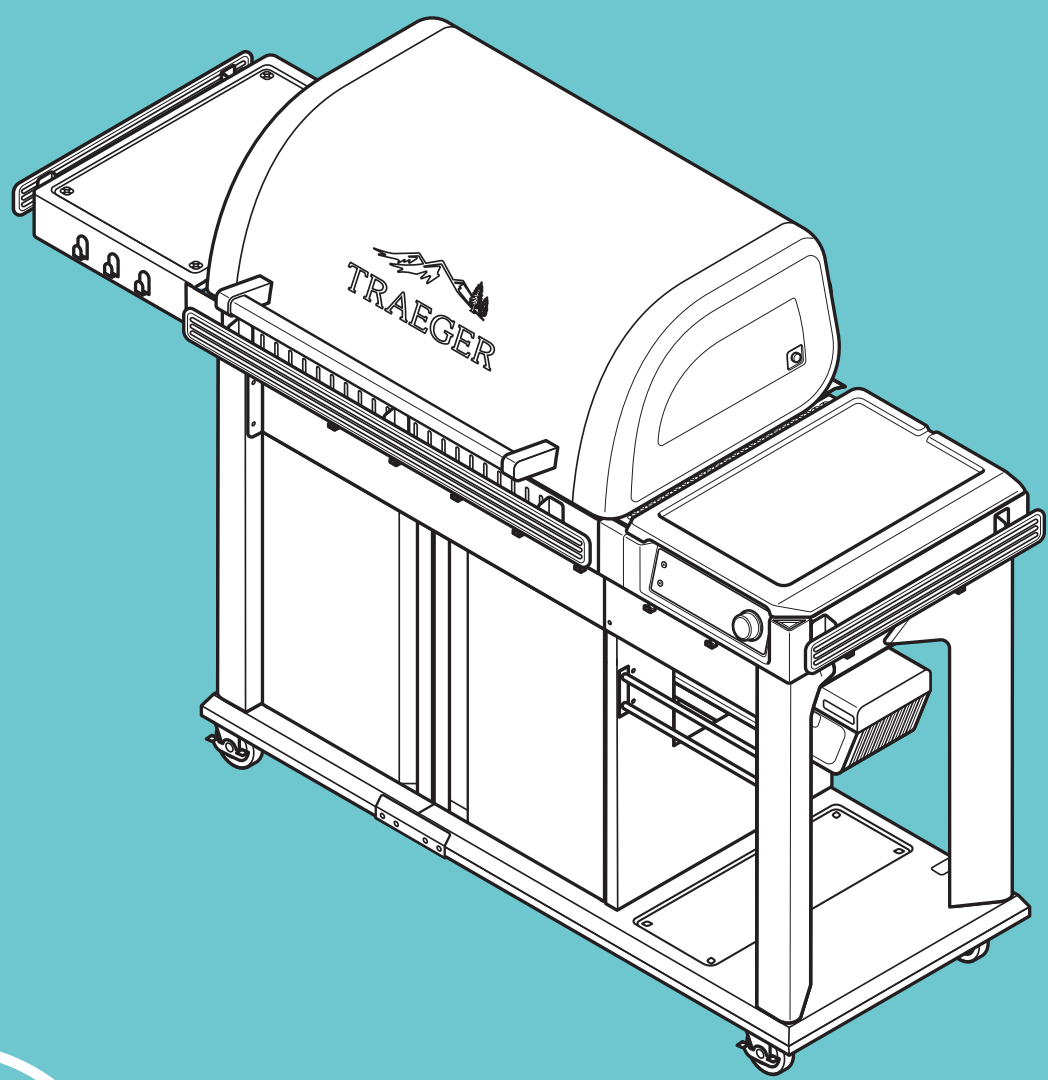

DECKEL & INNENTEILE DES GRILLS

KAPITEL 4

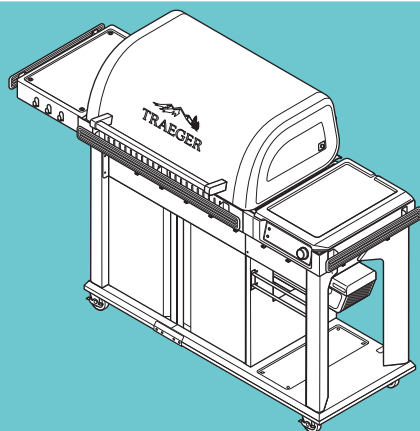

1 DECKEL DER PELLETKAMMER ANBRINGEN

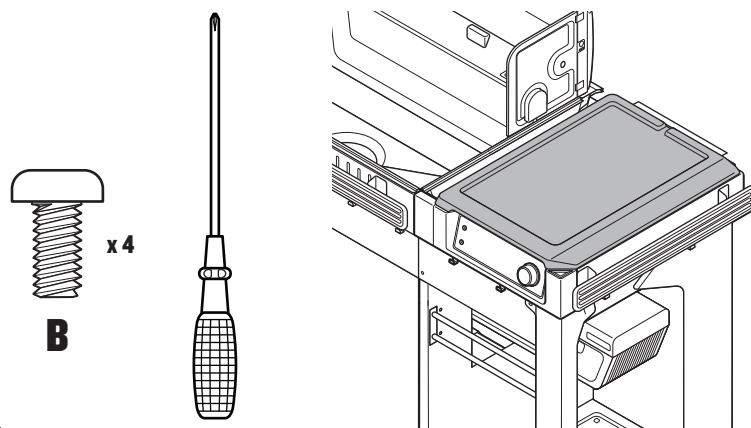

PROFI-TIPP: Ziehen Sie alle Schrauben zunächst handfest an und ziehen Sie sie dann mit einem Schraubendreher fest.

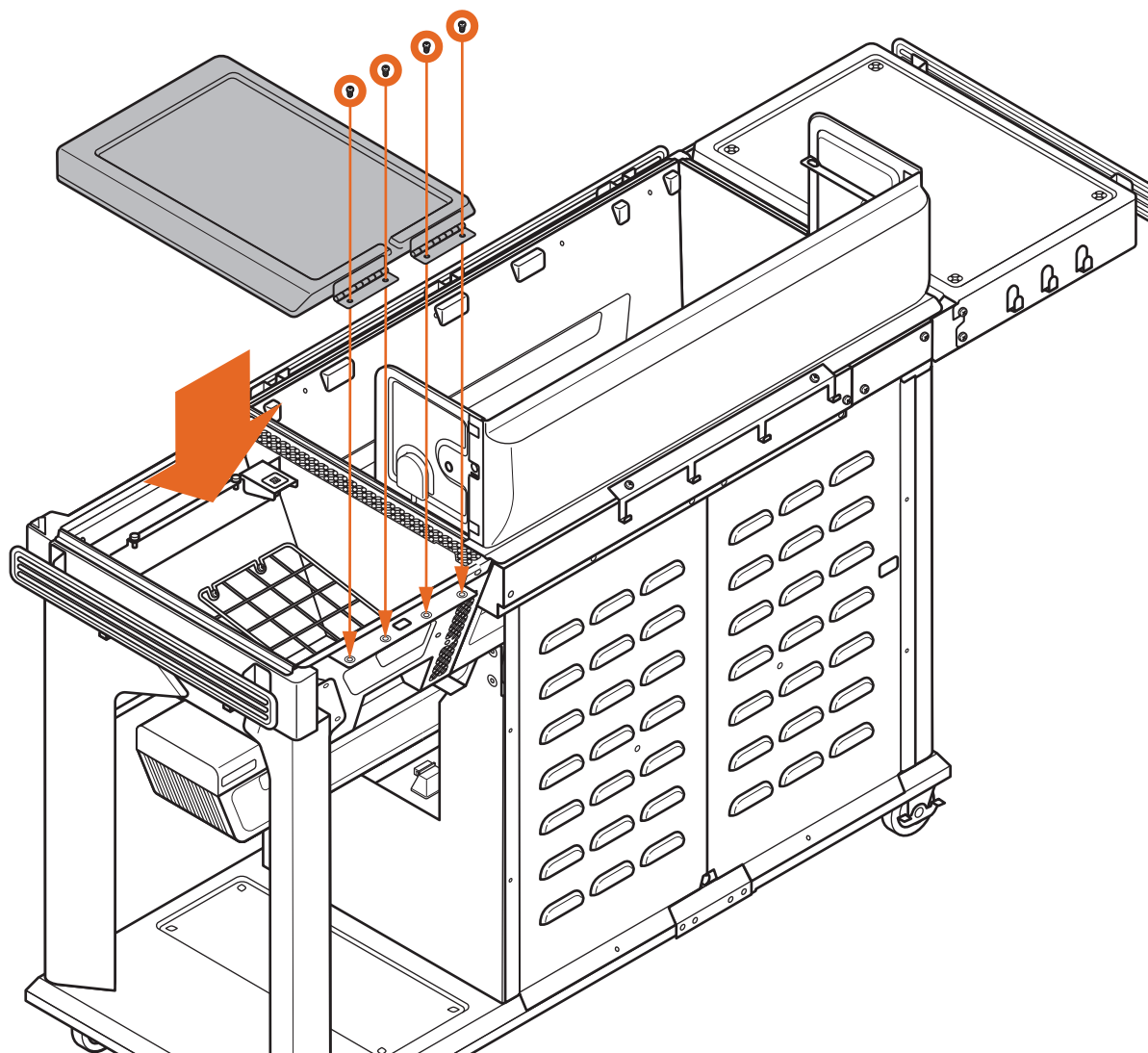



2 FETTABLAUF Rinne, GLUTSCHUTZ UND HITZELEITBLECH EINBAUEN

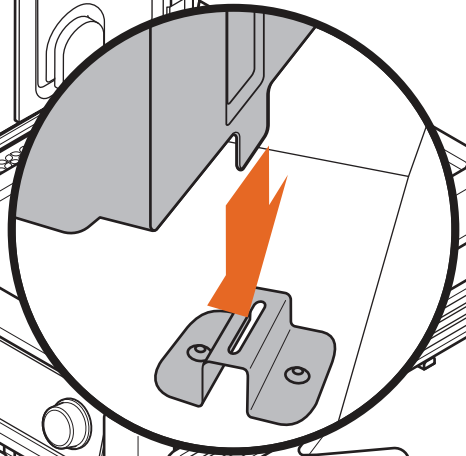
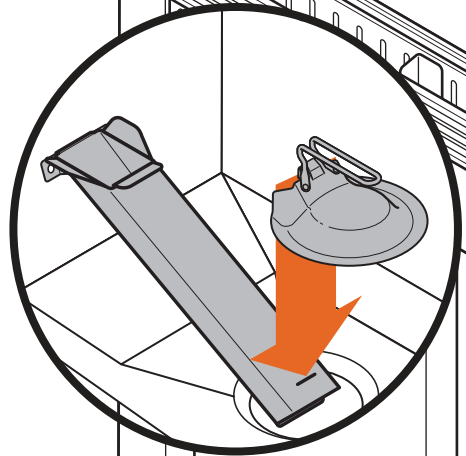
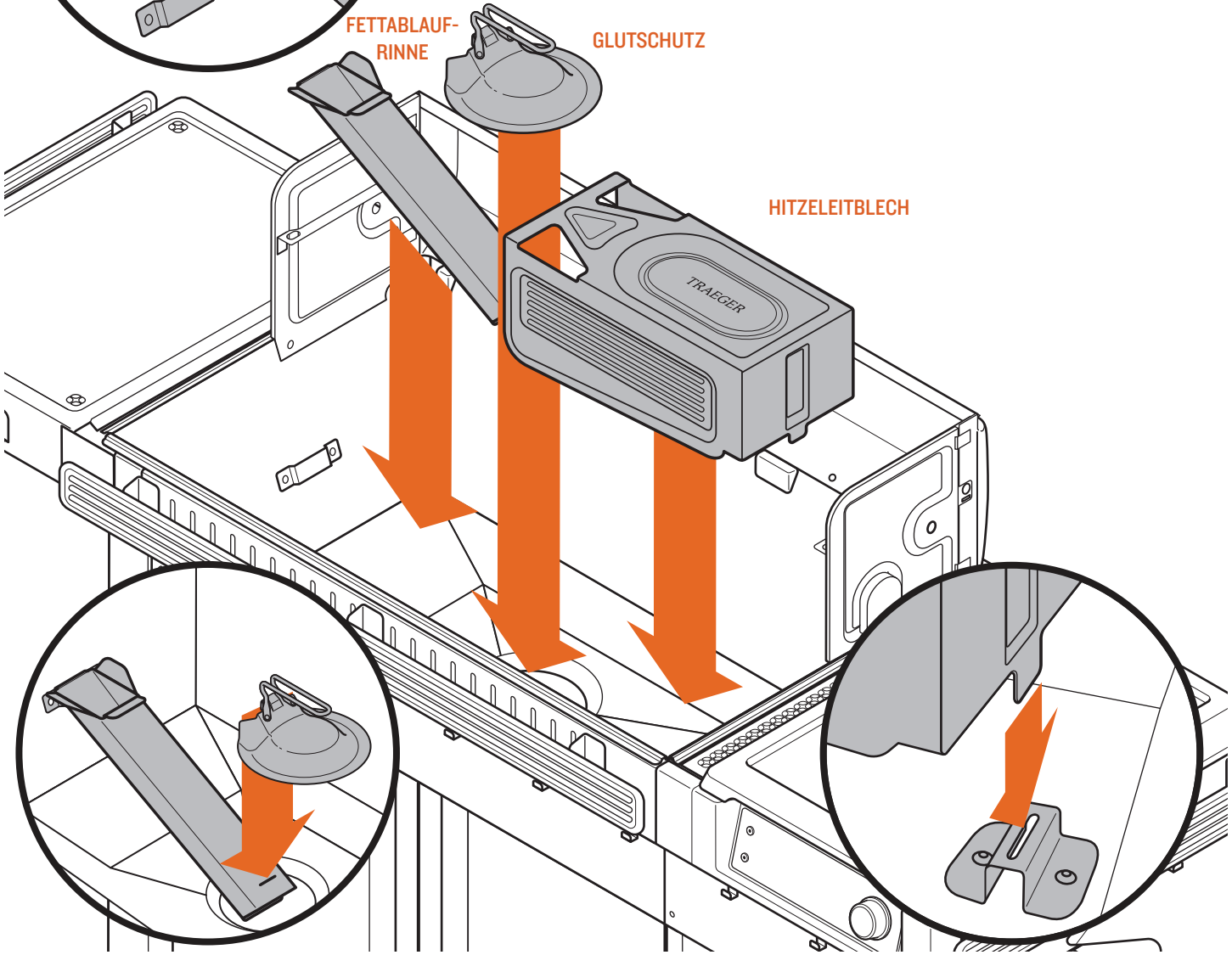
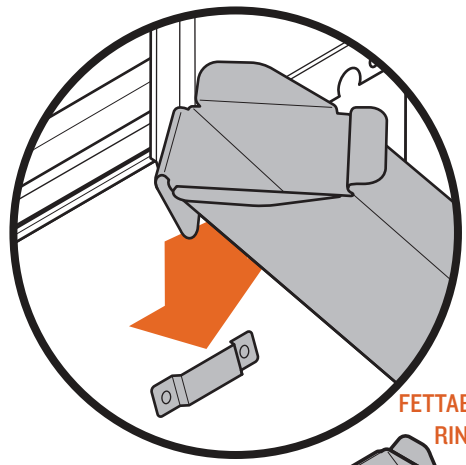
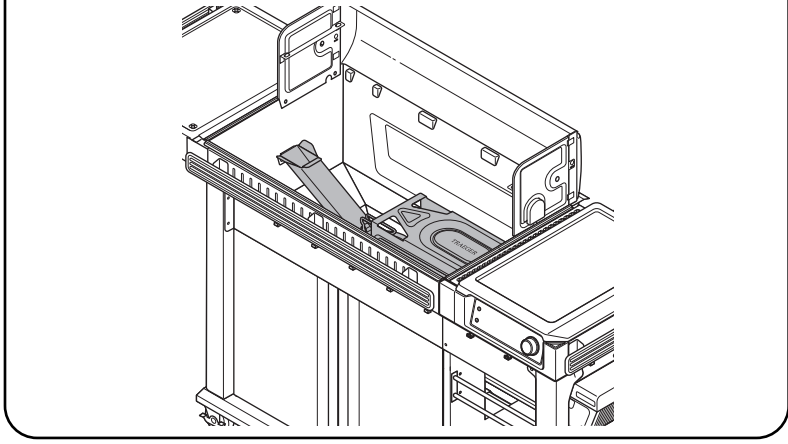
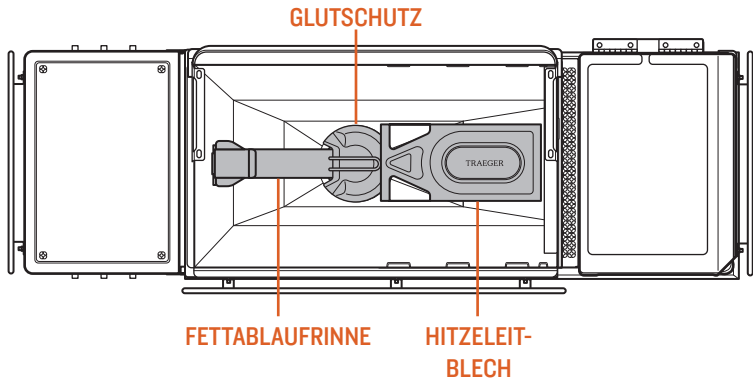



3 TROPFSCHALE EINBAUEN

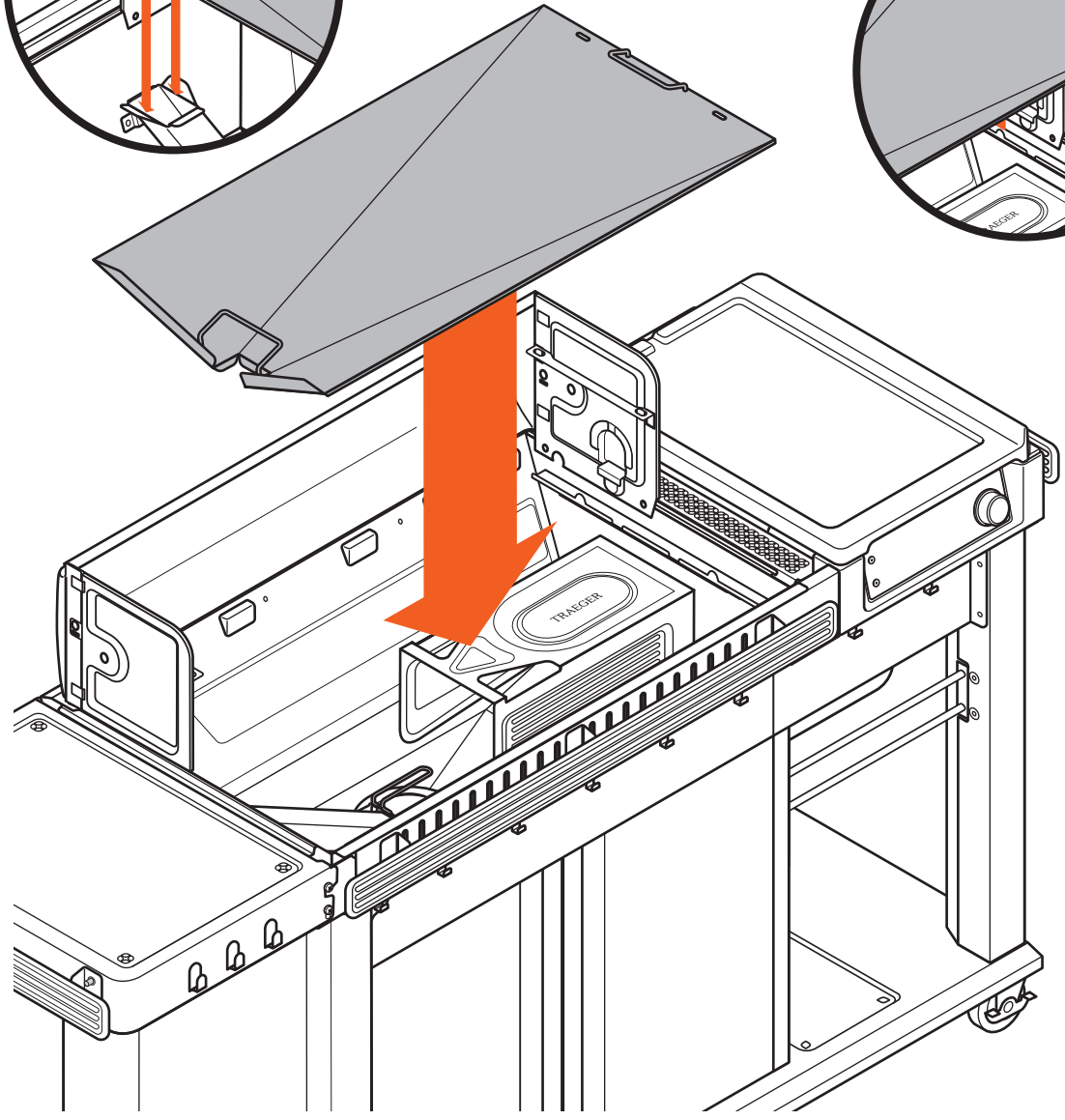
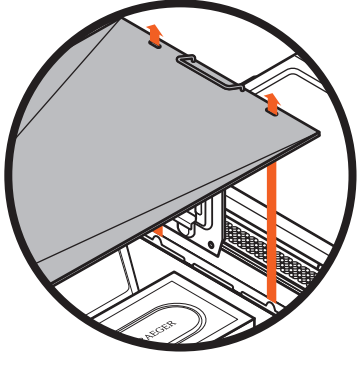
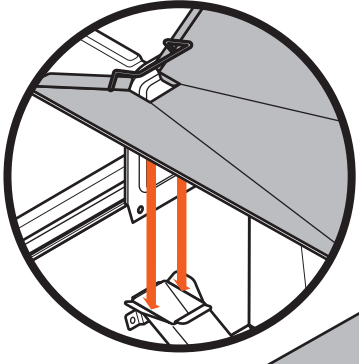
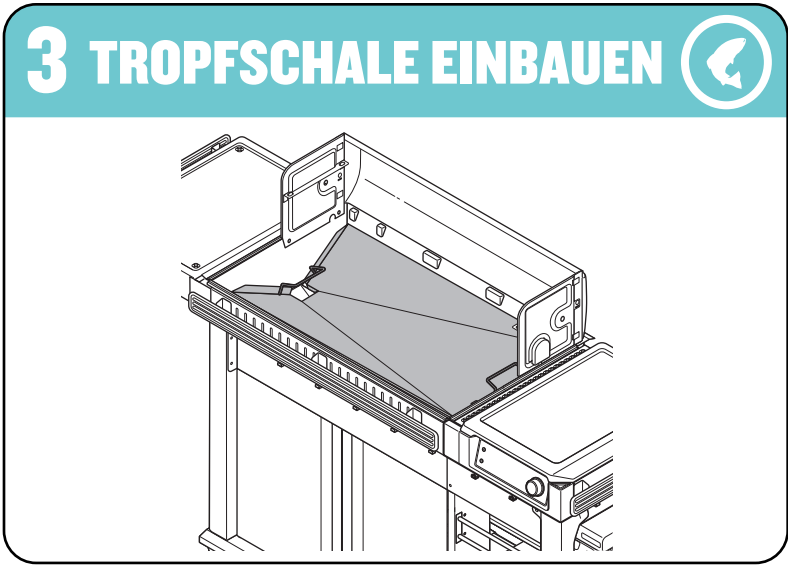



4A DECKELGRIFF ANBRINGEN

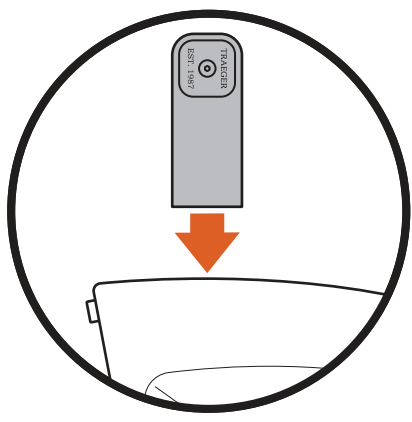
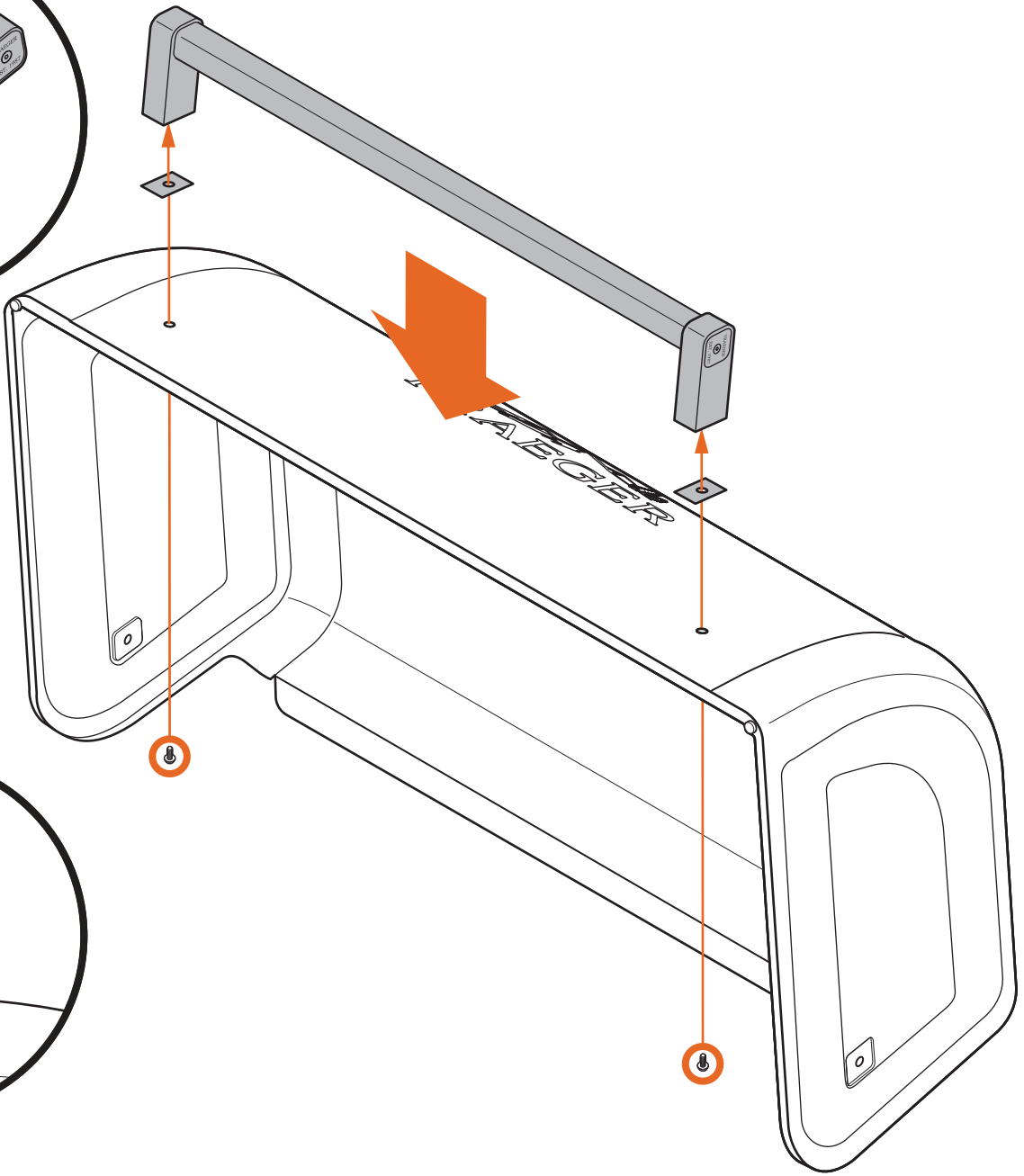
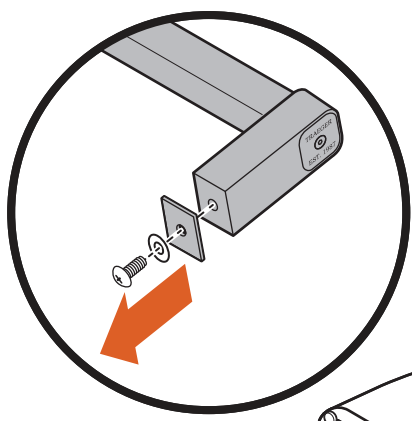
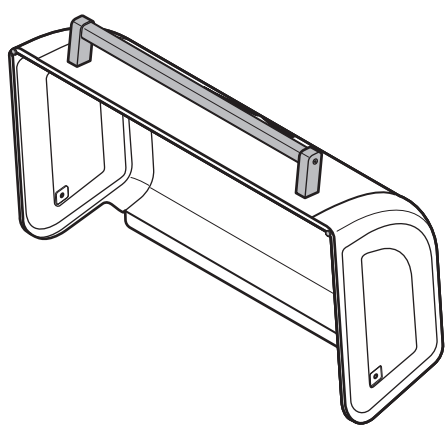



 **PROFI-TIPP:** Bringen Sie den Deckel zu zweit an.

4B DECKEL ANBRINGEN

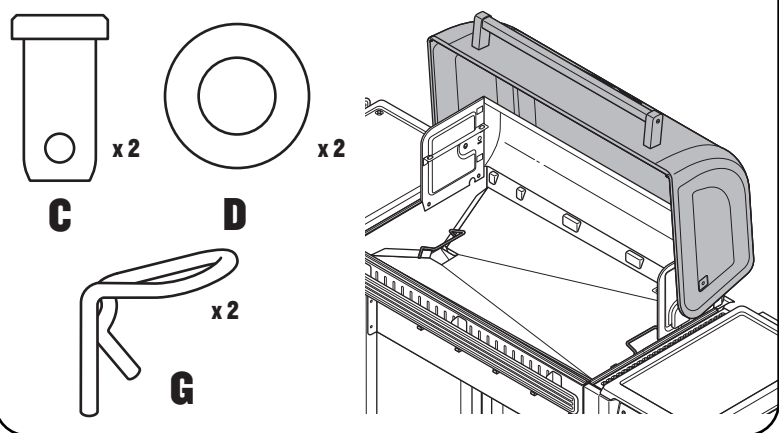

 **PROFI-TIPP:** Befestigen Sie die Splintbolzen C bei geschlossenem Deckel und öffnen Sie dann den Deckel, um G und D einzubauen.

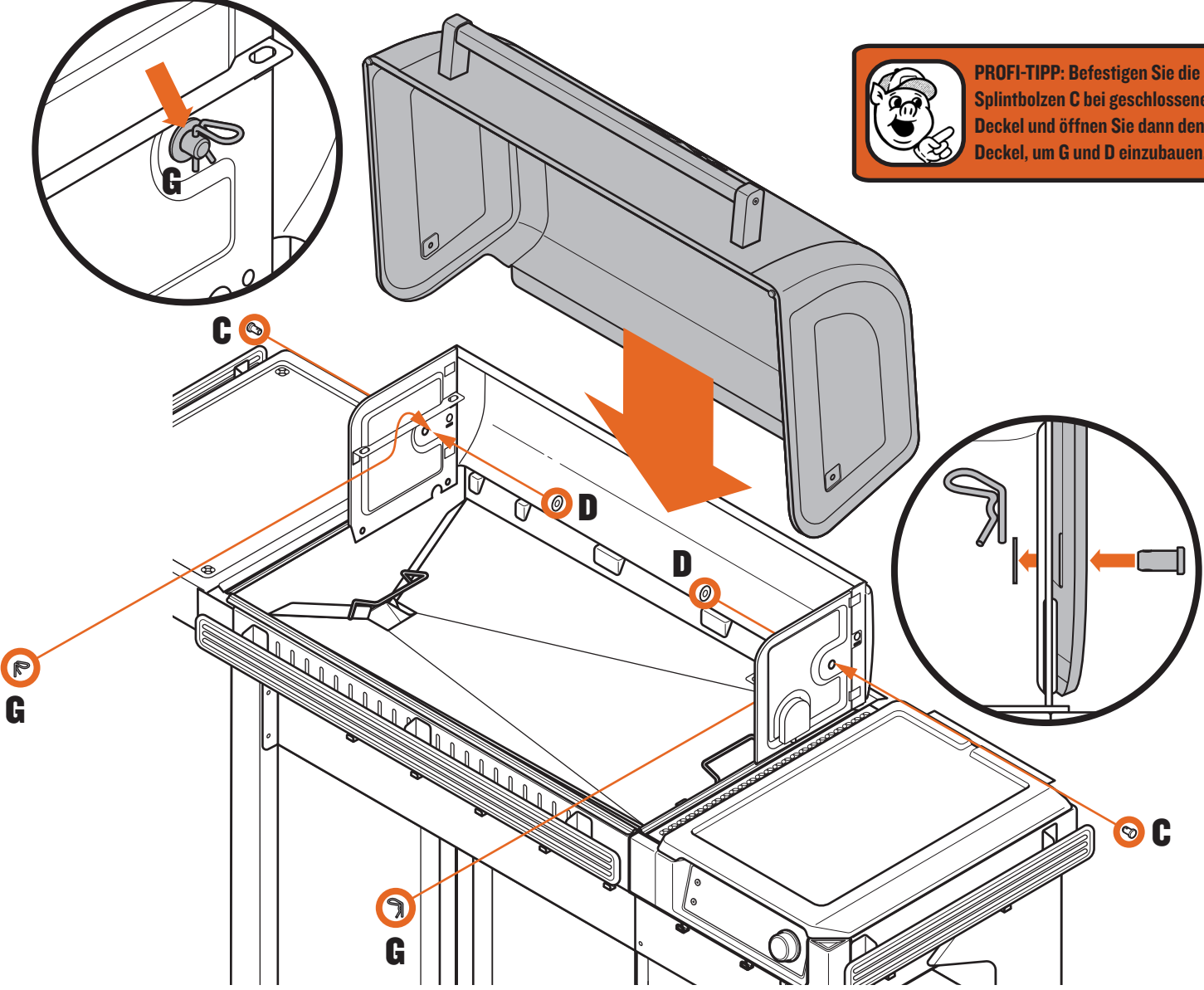

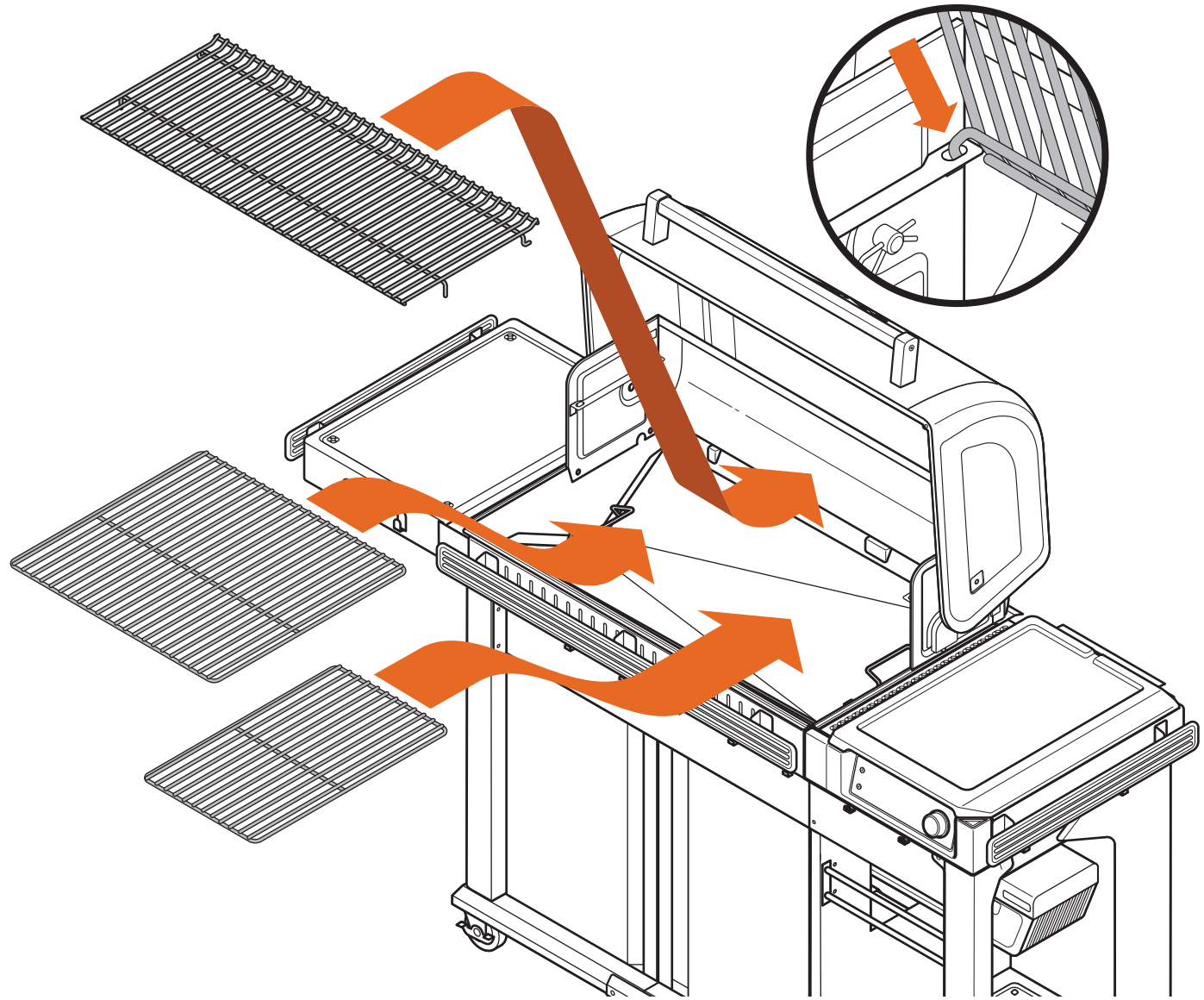
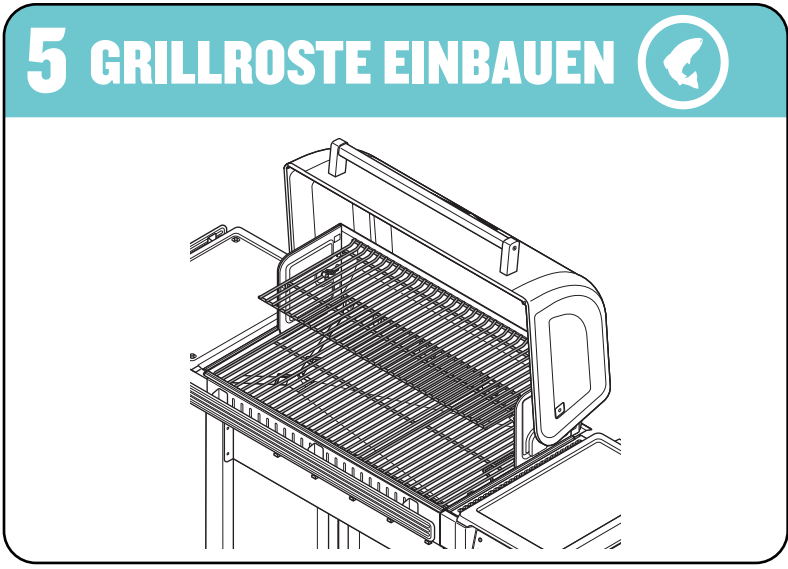



6 FETT- UND ASCHEBEHÄLTER EINBAUEN

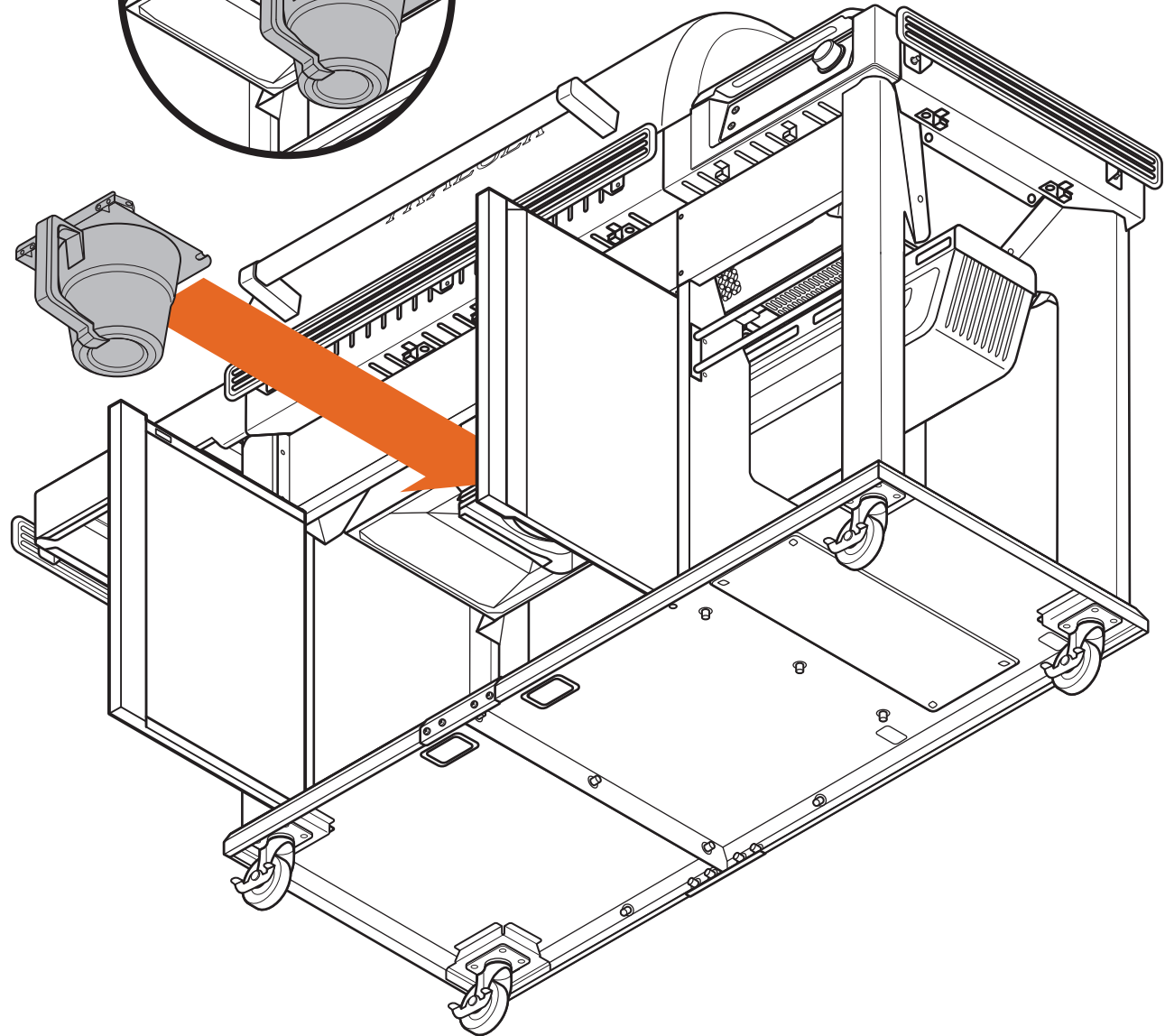
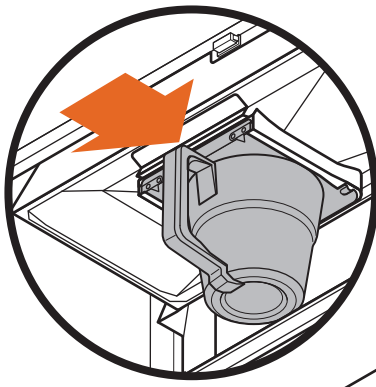
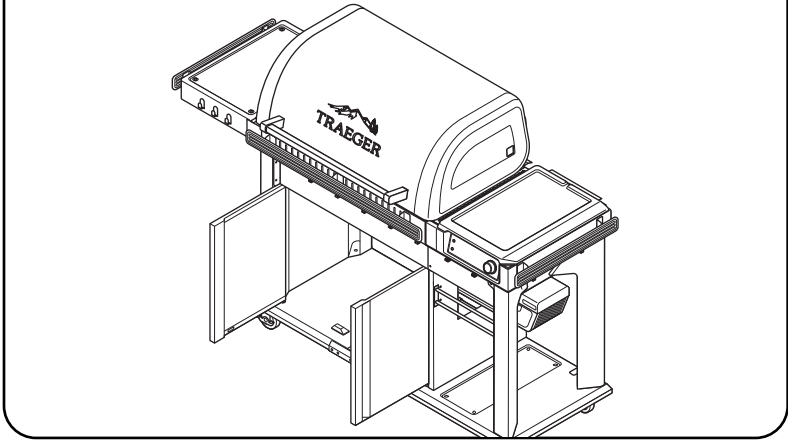

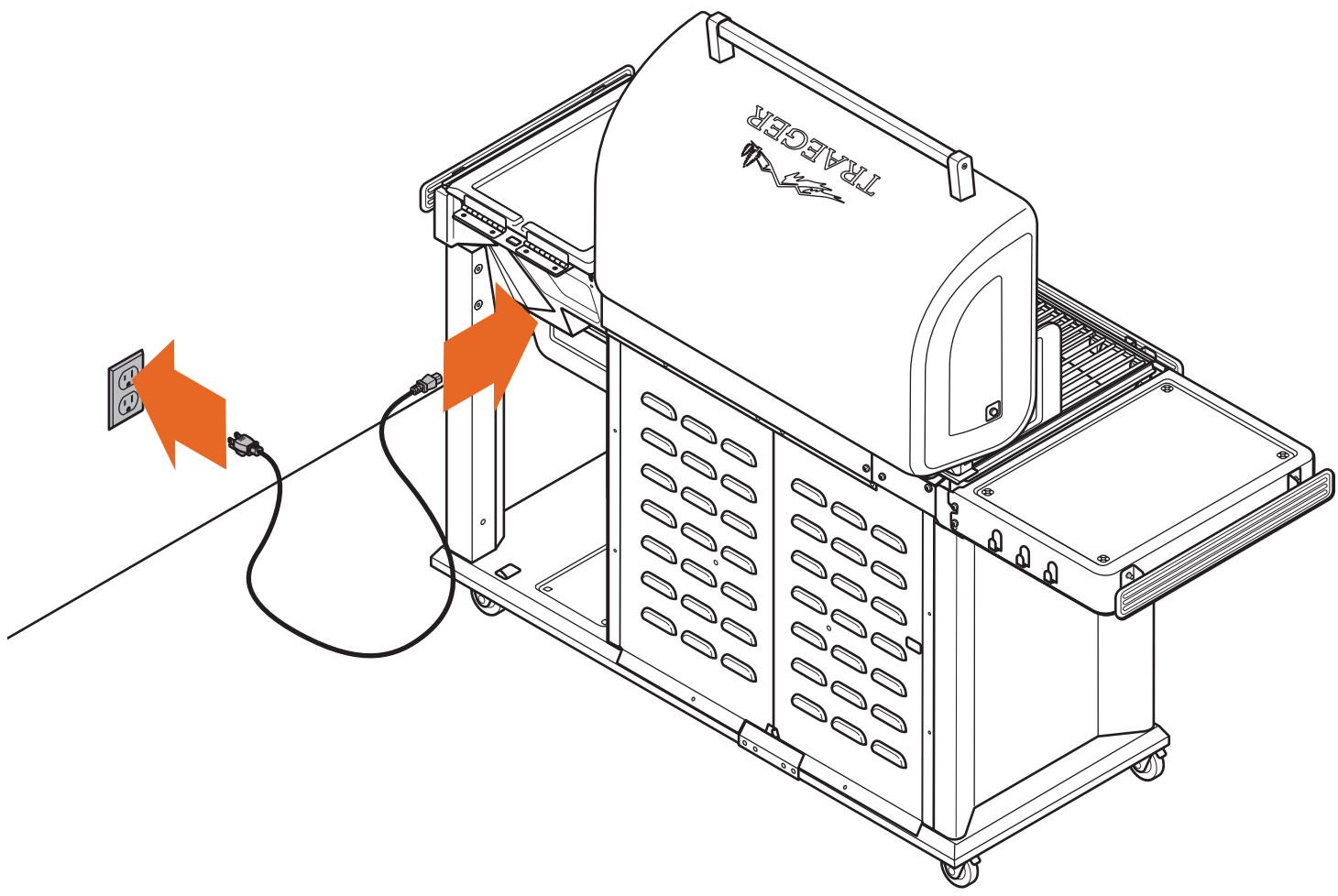
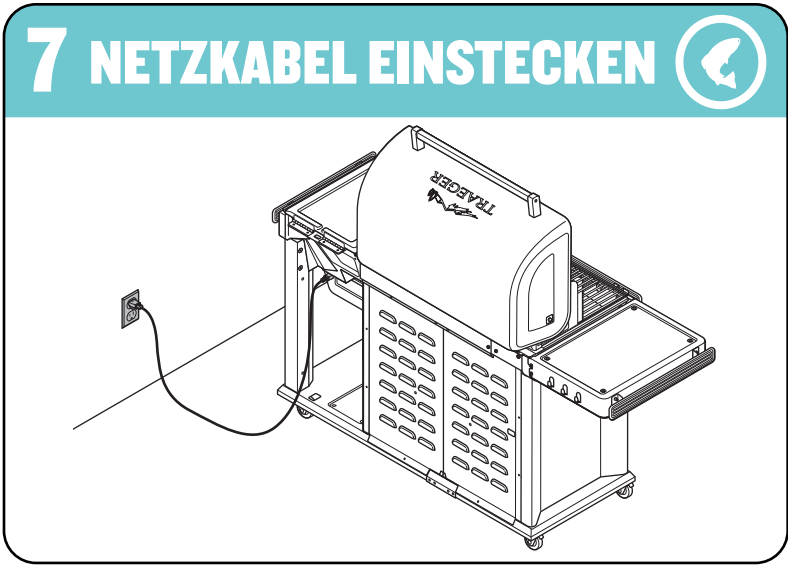

**GUTE ARBEIT!
KAPITEL 4 ABGESCHLOSSEN!**

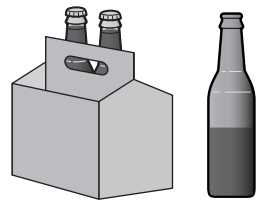

AUFBEWAHRUNG VON TEILEN UND ZUBEHÖR



WARNUNG! LEGEN SIE KEINE GRILLABDECKUNGEN ODER BRENNBAREN GEGENSTÄNDE IN DEN LAGERBEREICH UNTER DEM GRILL.

Kabelgebundener Temperaturfühler und Netzkabel

AUFBEWAHRUNG (NACH JEDEM GRILLEN):

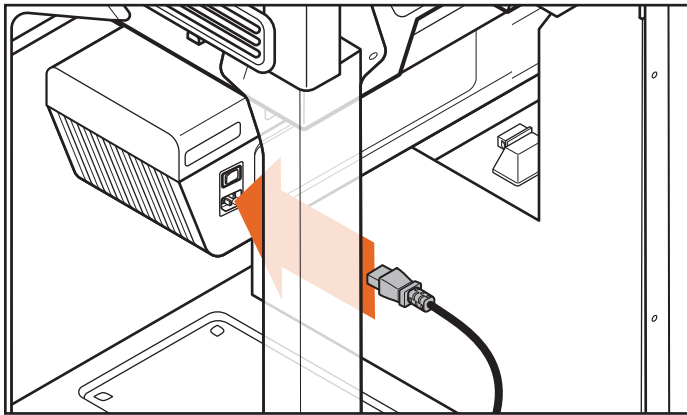
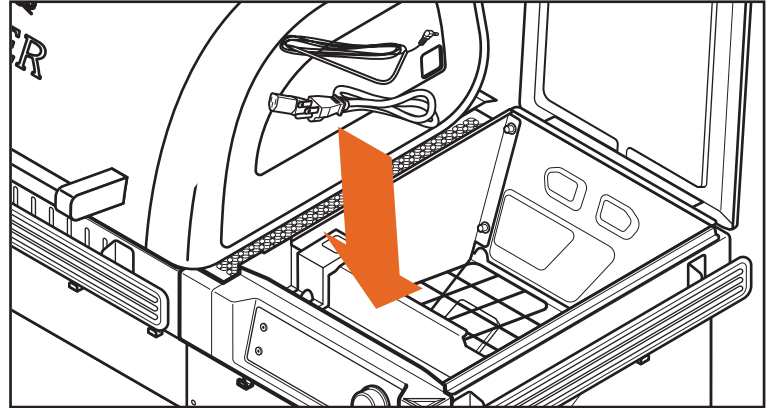
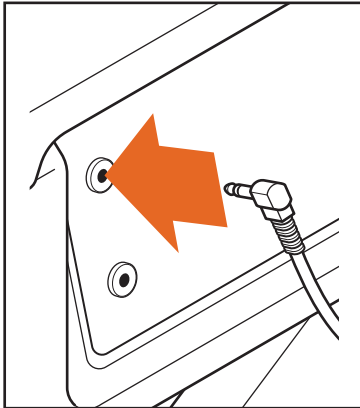

Grillroste, Tropfschale, Fettablaufrinne und Glutschutz

AUFBEWAHRUNG WÄHREND DER REINIGUNG:

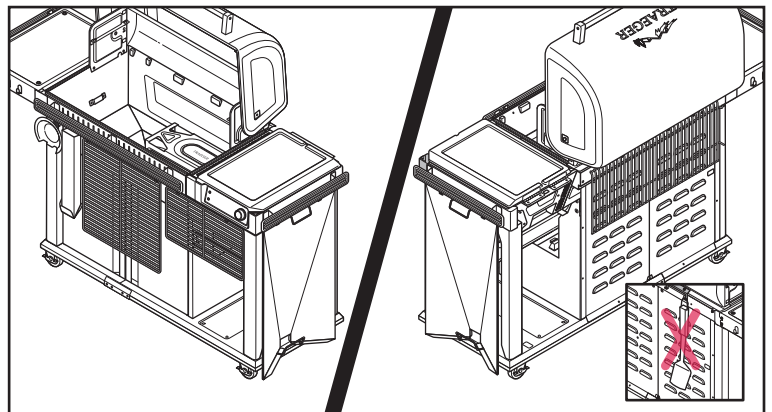
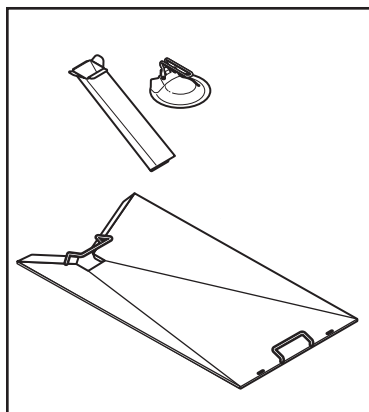
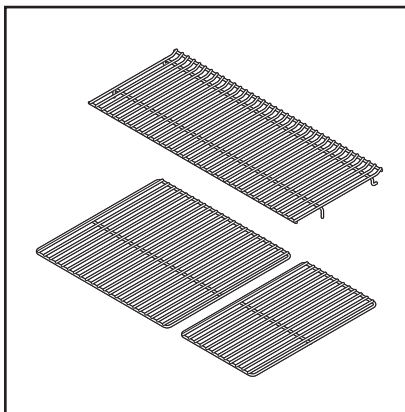

PROFI-TIPP: Hängen Sie keine Kochutensilien zur Aufbewahrung an die Rosthaken. Dadurch könnten die Utensilien beschädigt werden.



AUFBEWAHRUNG VON TEILEN UND ZUBEHÖR (FORTS.)

Pelletkammer

Wenn Sie Ihren Traeger Woodridge-Grill längere Zeit nicht verwenden, entfernen Sie die Pellets aus der Kammer.

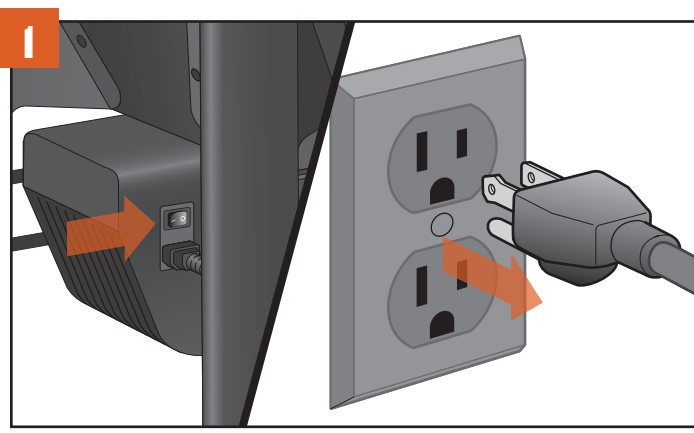

Stellen Sie den Netzschalter auf AUS (0) und ziehen Sie das Netzkabel. Wenn der Grill noch warm ist, lassen Sie ihn völlig abkühlen.

HINWEIS: Der Stecker kann je nach Land oder Region variieren.

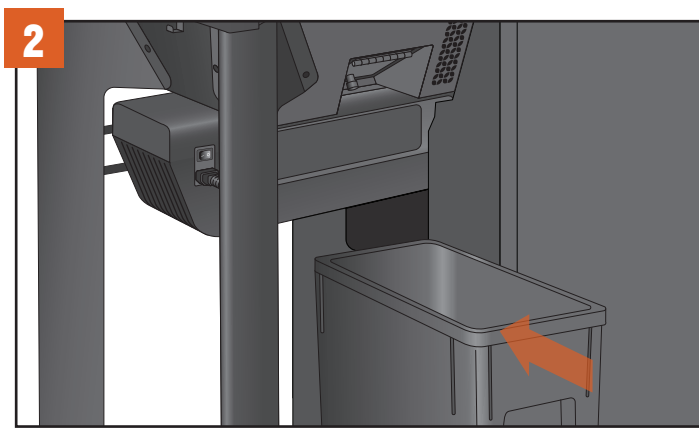

Bevor Sie die Pelletkammer entleeren, platzieren Sie den Traeger StayDry Pelletbehälter (separat erhältlich) direkt unter der Pellet-Entleerungsklappe.

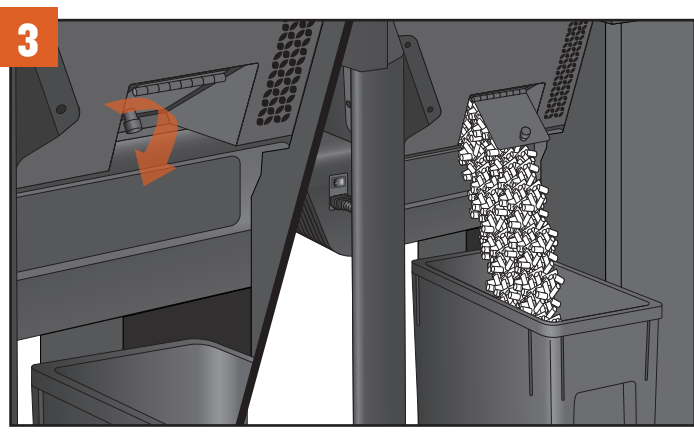

Schrauben Sie den Knopf auf der Rückseite des Förderschneckengehäuses ab und öffnen Sie die Pellet-Entleerungsklappe. Die Pellets werden in den StayDry Pelletbehälter entleert. Saugen Sie alle Sägemehlreste aus der Pelletkammer und von der Förderschnecke ab.

! WARNUNG! LEEREN SIE DIE PELLETKAMMER ERST, WENN DER GRILL VOLLSTÄNDIG ABGEKÜHLT IST UND DER STROM AUSGESCHALTET IST. ANDERNFALLS KÖNNEN DIE PELLETS SEHR HEISS SEIN.

! WARNUNG! STECKEN SIE DIE HAND NICHT ÜBER DEN SICHERHEITSROST HINAUS IN DIE PELLETKAMMER.



VERBINDUNG MIT DEM GRILL HERSTELLEN

Unser Engagement für die Bereitstellung erstklassiger Produkte und Erlebnisse bedeutet, dass wir ständig daran arbeiten, die Leistung und Funktionen des Grills zu verbessern. Wir empfehlen Ihnen dringend, Ihren Traeger Woodridge Grill mit WiFIRE zu verbinden. Befolgen Sie dazu die nachstehende Anleitung. Wenn der Grill angeschlossen und eingeschaltet ist, werden Updates automatisch heruntergeladen, um zu gewährleisten, dass der Grill immer optimal funktioniert.

WICHTIG:

- Achten Sie darauf, dass auf Ihrem Smartphone oder Tablet das neueste Betriebssystem ausgeführt wird und dass Bluetooth eingeschaltet ist.
- Wenn Sie ein Android-Gerät verwenden, aktivieren Sie die Standortdienste.
- Der Grill muss eingeschaltet sein, um ihn mit dem Haus-WLAN zu verbinden. Achten Sie darauf, dass der Hauptschalter **INGESCHALTET** ist und leuchtet.
- Das Signal Ihres WLAN-Routers zu Hause muss 2,4 GHz haben (ein Dualband-Router sollte auch funktionieren). Das 2,4-GHz-Band ist derzeit der Branchenstandard für vernetzte Haushaltsgeräte. Es hat eine bessere Reichweite und durchdringt Wände/Decken/Hindernisse besser als 5 GHz, das der Grill nicht erkennen kann.

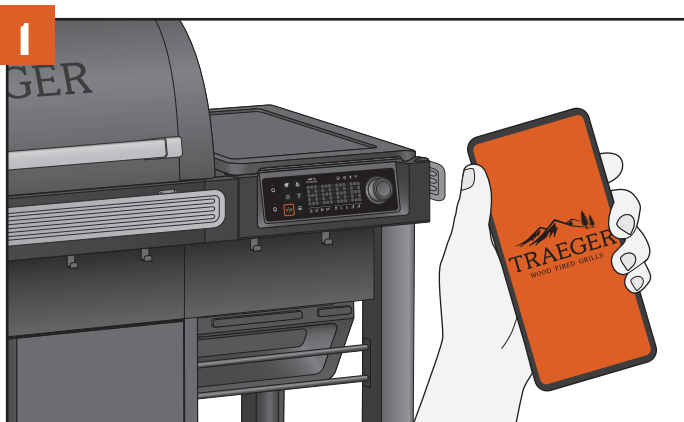
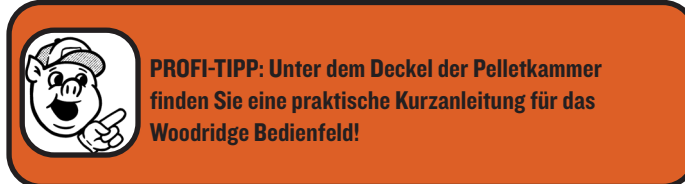
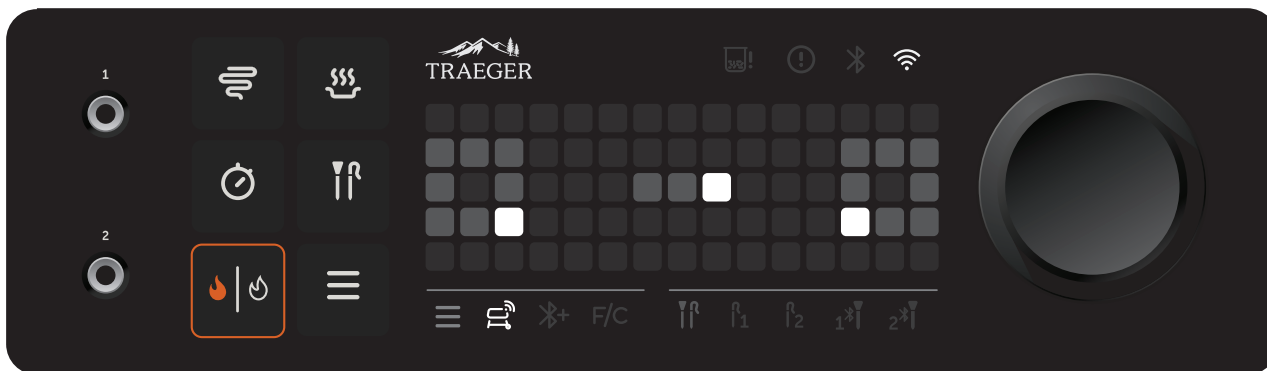

Gehen Sie zum Apple App Store oder Android Google Play Store, um die neueste Version der Traeger-App herunterzuladen.

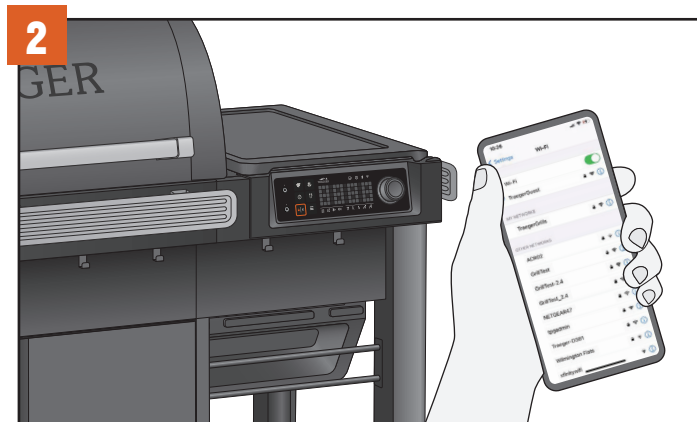

Achten Sie darauf, dass Ihr Smartphone oder Tablet mit dem WLAN verbunden ist, mit dem Sie den Grill verbinden möchten. Das Routersignal muss 2,4 GHz haben, da der Grill mit 5 GHz nicht kompatibel ist.

VERBINDUNG MIT DEM GRILL HERSTELLEN (FORTS.)



Tippen Sie nach dem Einschalten des Grills auf die Menütaste. Sie sehen, wie das WLAN-Symbol des Grills in der Menüleiste unter der Punktmatrix aufleuchtet und die Animation eines WLAN-Signals mit einem Fragezeichen angezeigt wird. Drücken Sie das Auswahrad, um diese Option auszuwählen und den Verbindungsvorgang zu starten.

HINWEIS: Sie können durch die Menüoptionen navigieren, indem Sie nach dem Tippen auf die Menütaste das Auswahrad drehen. Beim Drehen des Rads leuchten die Menüleistensymbole unter der Punktmatrixanzeige auf, um die Auswahl anzuzeigen.

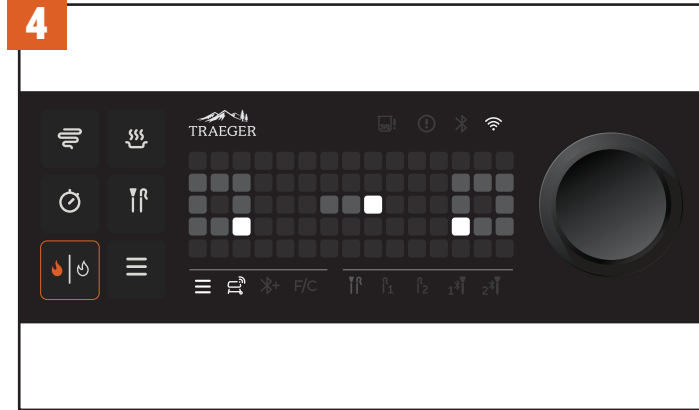

Nach der Auswahl von WiFIRE wird die obige Kopplungsanimation auf dem Bildschirm angezeigt. Dies zeigt an, dass der Grill ein Bluetooth Signal sendet und zur Kopplung bereit ist. Öffnen Sie auf Ihrem Smart-Gerät die Traeger-App und melden Sie sich bei Ihrem Konto an. Tippen Sie auf dem Startbildschirm der Traeger-App auf das Grillsymbol unten in der Bildschirmmitte, um eine Verbindung herzustellen.

Befolgen Sie die Anweisungen in der Traeger-App, um (1) Ihr Telefon mit dem Grill zu koppeln (über eine temporäre Bluetooth Verbindung), (2) den Grill mit Ihrem gewünschten 2,4-GHz-Heim-WLAN-Netzwerk zu verbinden und (3) den Einrichtungsvorgang des Grills abzuschließen.

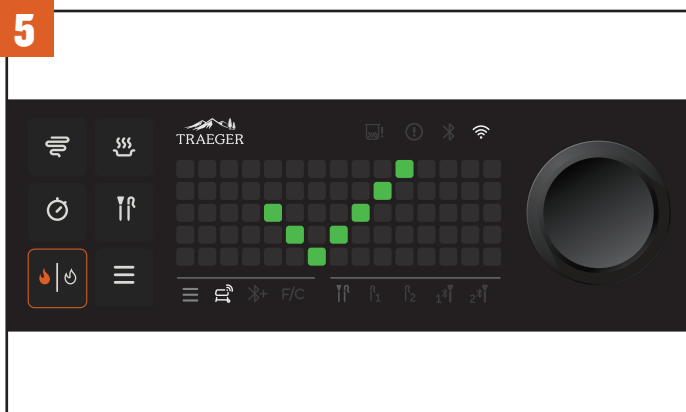

Auf dem Bedienfeld wird ein grünes Häkchen angezeigt, das angibt, dass Sie erfolgreich eine Verbindung zu WiFIRE hergestellt haben. Das WLAN-Symbol oben rechts über der Punktmatrixanzeige leuchtet durchgehend, wenn der Grill eine Verbindung hat.

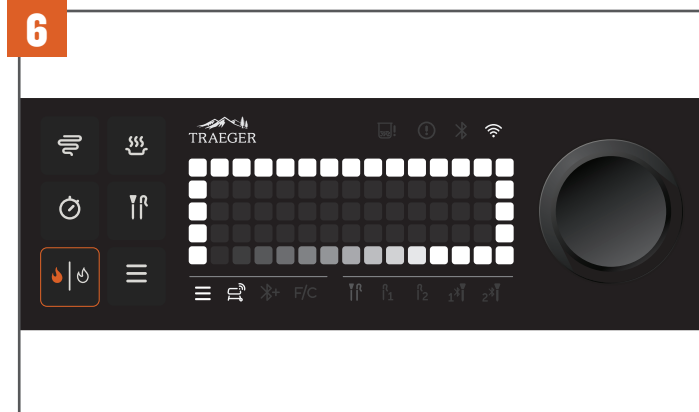

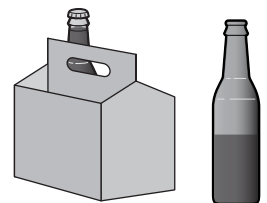

Nachdem eine Verbindung zu WiFIRE besteht, sehen Sie möglicherweise diese Animation auf Ihrem Bildschirm. Schalten Sie den Grill erst aus, wenn ein grünes Häkchen angezeigt wird. Dies bedeutet, dass der Grill ein Update herunterlädt und anwendet. Genau wie bei Ihrem Smartphone sorgen diese Updates dafür, dass Ihr Grill reibungslos, sicher und optimal funktioniert. Nachdem das Update abgeschlossen ist, sehen Sie ein grünes Häkchen und der Grill kehrt in den Ruhemodus zurück – und es kann losgehen!

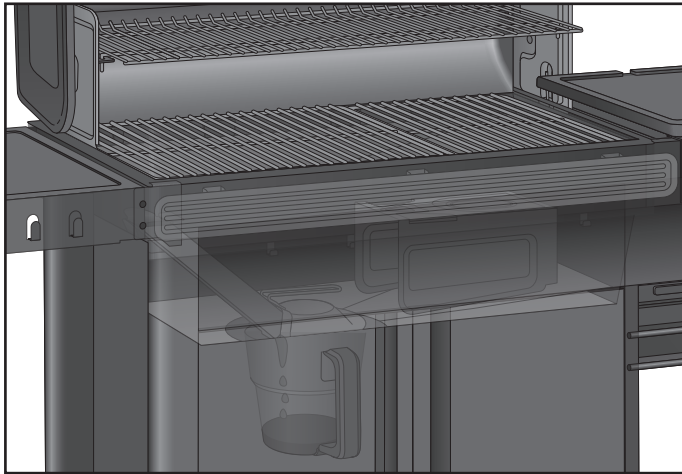

EINBRENNEN DES GRILLS

PROFI-TIPP: Das Einbrennen muss abgeschlossen sein, bevor Sie Lebensmittel auf dem Grill zubereiten. Für weitere Informationen scannen Sie hier, um den Einbrennleitfaden anzuzeigen.



WICHTIG:

- Achten Sie darauf, dass alle Komponenten ordnungsgemäß im Grill installiert sind und dass vor dem Einbrennen sämtliche Verpackungs-/Versandmaterialien entfernt wurden.
- Wischen Sie die schützende Fettschicht vor dem Einbrennen nicht von den Komponenten ab. Diese Beschichtung bietet eine haltbarere Einbrennschutzschicht.

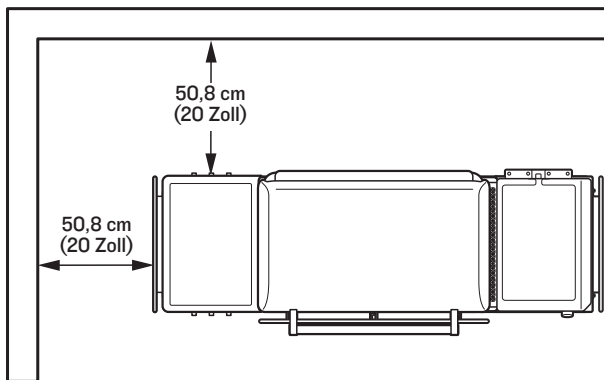

⚠️ WARNUNG Feuergefahr

- Halten Sie beim Betrieb Ihres Traeger Grills einen **MINIMALEN** Abstand von 50,8 cm (20 Zoll) zwischen dem Grill und allen brennbaren Gegenständen in der Nähe ein, einschließlich Holzgeländern, Hausverkleidungen, Fensterrahmen, Möbeln, Bäumen und Abfallbehältern usw.

Bevor Sie auf Ihrem Grill kochen können, muss er eingebrannt werden. Dabei handelt es sich um einen berührungslosen Vorgang, bei dem der leere Grill auf eine sehr hohe Temperatur erhitzt wird. Dieser Einbrennzyklus stellt sicher, dass der Grill von allen Fabrikrückständen gereinigt, vorbereitet und für optimale Leistung bereit ist.

⚠️ GEFAHR Gefahr durch Kohlenmonoxid

Bei der Verbrennung von Holzpellets entsteht Kohlenmonoxid, das zu Krankheit, schweren Verletzungen und/oder zum Tod führen kann. Um zu verhindern, dass dieses farblose, geruchlose Gas Sie, Ihre Familie, Ihre Haustiere oder andere gefährden kann, befolgen Sie diese Anleitung:

- Betreiben Sie Ihren Traeger Grill nur im Freien in einem gut belüfteten Bereich. Dieser Grill ist **AUSSCHLISSLICH** für die **BENUTZUNG IM FREIEN** bestimmt.
- Benutzen Sie Ihren Traeger Grill **niemals** in einem geschlossenen Bereich oder in einem Bereich ohne ausreichende Belüftung.
- Erkennen Sie die Symptome einer Kohlenmonoxid-Vergiftung: Kopfschmerzen, Schwindel, Schwäche, Übelkeit, Erbrechen, Müdigkeit und Verwirrung. Kohlenmonoxid verringert die Fähigkeit des Blutes, Sauerstoff zu transportieren. Ein zu niedriger Sauerstoffgehalt im Blut kann zu Bewusstlosigkeit und Tod führen.
- Sollten Sie oder andere Personen erkältungs- oder grippeähnliche Symptome entwickeln, während Sie grillen oder sich in der Umgebung eines Grills aufhalten, suchen Sie einen Arzt auf. Kohlenmonoxid-Vergiftungen werden oft zu spät bemerkt, da sie leicht mit Erkältungs- oder Grippeerkrankungen verwechselt werden.
- Alkohol- oder Drogenkonsum verstärken die Effekte einer Kohlenmonoxid-Vergiftung.
- Kohlenmonoxid gefährdet insbesondere: Mutter und Kind während der Schwangerschaft, Kleinkinder, ältere Menschen, Raucher und Menschen mit Herz-Kreislauf-Erkrankungen wie beispielsweise Anämie oder Herzerkrankungen.

⚠️ WARNUNG Feuergefahr

- Verwenden Sie **niemals** Benzin, Petroleum, Kerosin, Feuerzeugbenzin oder andere brennbare Materialien, um ein Feuer zu entzünden oder „aufzufrischen“.
- Verwenden oder lagern Sie **niemals** brennbare Flüssigkeiten oder andere brennbare Materialien in der Nähe des Grills.

⚠️ WARNUNG Verbrennungsgefahr

Asche sollte vor der Handhabung immer vollständig abgekühlt sein. Aschereste sollten in einem Metallbehälter mit gut schließendem Deckel entsorgt werden. Der geschlossene Aschebehälter muss bis zur endgültigen Entsorgung auf nicht brennbarem Untergrund und in sicherem Abstand zu brennbaren Materialien aufbewahrt werden. Die Asche sollte bis zu ihrer Entsorgung im geschlossenen Behälter aufbewahrt werden.

⚠️ WARNUNG Verwenden Sie keine Heizpellets

Verwenden Sie niemals Heizpellets im Grill, da diese möglicherweise gefährliche Verunreinigungen und Zusätze enthalten und den Grill beschädigen können.

EINBRENNEN DES GRILLS FORTSETZUNG

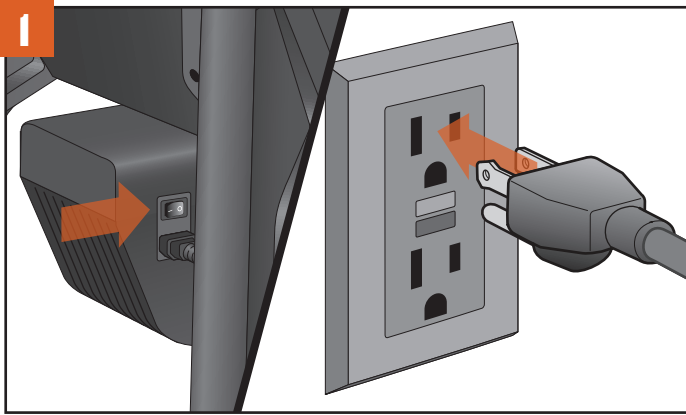

Schließen Sie das Netzkabel bei ausgeschaltetem (0) Hauptschalter an den Grill an. Stecken Sie dann das Netzkabel in eine ordnungsgemäß geerdete Steckdose, die durch einen Fehlerstrom-Schutzschalter (GFCI) geschützt ist.

HINWEIS: Der Stecker kann je nach Land oder Region variieren.

⚠️ WARNUNG! GEFAHR DURCH ELEKTRISCHEN SCHLAG
GEFÄHRLICHE SPANNUNGEN KÖNNEN ZU STROMSCHLAG, VERBENNUNGEN ODER ZUM TOD FÜHREN.

- DIE STROMKREISE UND STECKDOSEN, DIE FÜR DEN BETRIEB DIESES TRAEGER GRILLS VERWENDET WERDEN, MÜSSEN MIT EINEM FEHLERSTROM-SCHUTZSCHALTER (GFCI) AUSGESTATTET SEIN.

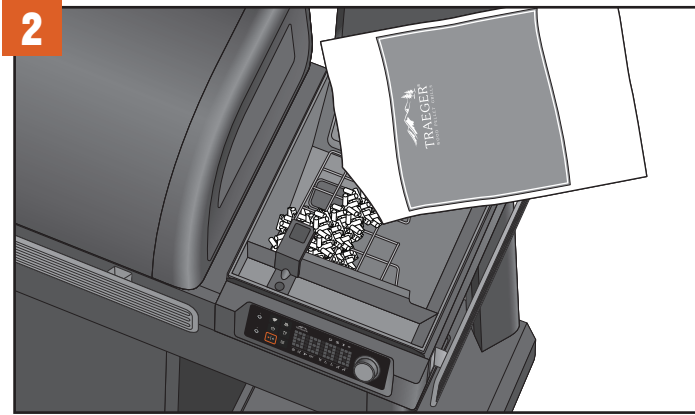

Um Pellets hinzuzufügen, öffnen Sie den Deckel der Pelletkammer und prüfen, ob sich Fremdkörper in der Förderschnecke befinden. Füllen Sie die Pelletkammer mindestens bis zum Sicherheitsrost mit Pellets und schließen Sie den Deckel.

VERWENDEN SIE AUSSCHLIESSLICH HARTHOLZ-PELLETS DER MARKE TRAEGER. Dieses Produkt wurde ausschließlich unter Verwendung von Traeger-Pellets entwickelt und optimiert. Traeger-Pellets werden nach strengen Qualitäts- und Leistungsstandards hergestellt. Die Verwendung von Pellets, die nicht von Traeger hergestellt wurden, kann zu abweichender Leistung, geschmacklichen Mängeln und Temperaturschwankungen führen.

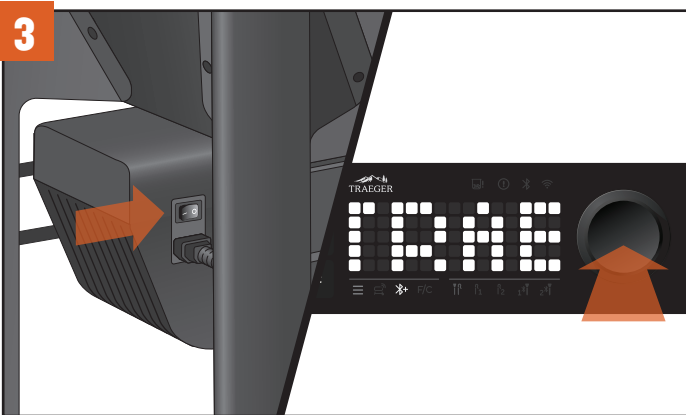

Schalten Sie den Hauptschalter an der Rückseite des Förderschneckengehäuses EIN (I). Drücken Sie auf das Auswahrad, um den Ruhemodus zu verlassen. „TRAEGER“ läuft über den Bildschirm und zeigt an, dass der Grill eingeschaltet ist.



Drehen Sie das Auswahrad, um die Grilltemperatur auf 350 °F (177 °C) einzustellen, und drücken Sie dann auf das Auswahrad. Drücken Sie auf die Zünd-/Abschalttaste.

PROFI-TIPP: Dieser Einbrennvorgang ist wichtig, um eine einwandfreie Grillfunktion zu gewährleisten. Stellen Sie sicher, dass alle internen Komponenten vor diesem Einbrennprozess ordnungsgemäß eingebaut wurden und dass sich während dieses Vorgangs keine Lebensmittel auf den Grillrosten befinden.



Die Grilltemperatur wird angezeigt, während sie auf die eingestellte Temperatur ansteigt.

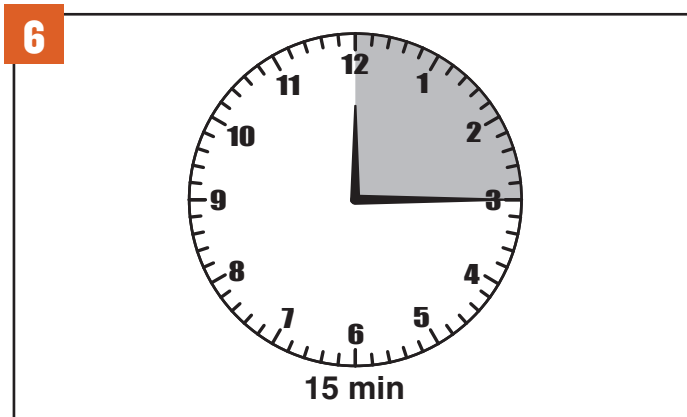

Nachdem der Grill 350 °F (177 °C) erreicht hat, lassen Sie ihn 15 Minuten lang laufen. Während der Grill einbrennt, können sich dunkler oder übermäßiger Rauch und Asche bilden. Dies ist normal und wird bei späteren Einschaltvorgängen weniger auftreten.

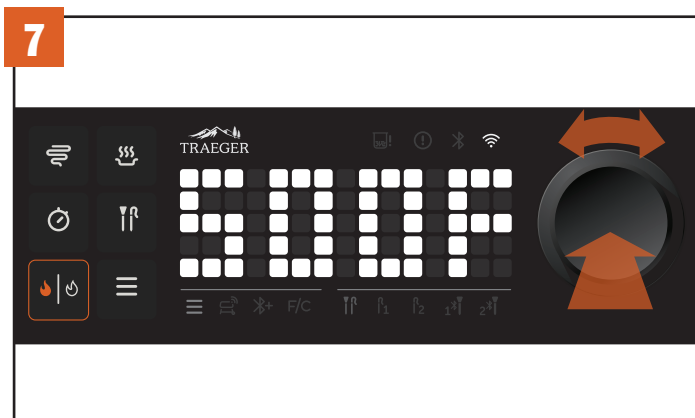

Erhöhen Sie die Temperatur nach 15 Minuten bei 350 °F (177 °C) auf 500 °F (260 °C).

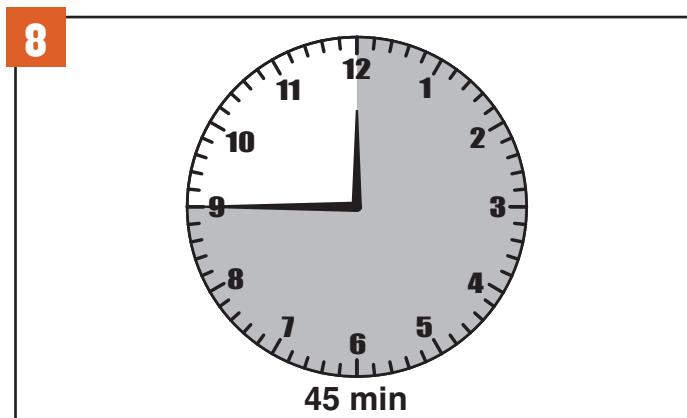

Nachdem der Grill eine Temperatur von 500 °F (260 °C) erreicht hat, lassen Sie ihn weitere 45 Minuten laufen, um zu gewährleisten, dass der Einbrennvorgang ordnungsgemäß abgeschlossen wird.

HINWEIS: Es kann bis zu einer Stunde dauern, bis die erste Einbrenntemperatur erreicht ist.

EINBRENNEN DES GRILLS FORTSETZUNG

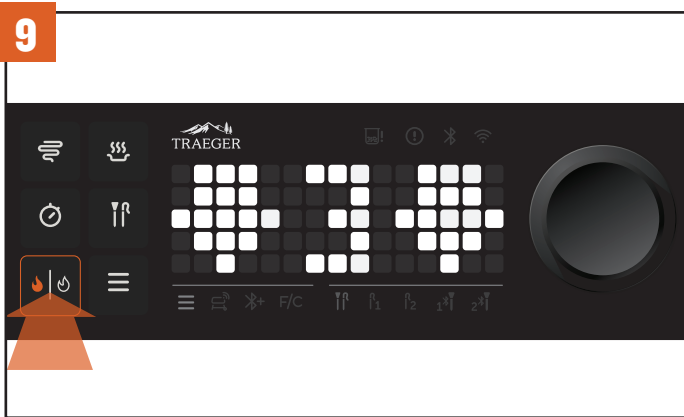

Schalten Sie den Grill nach 45 Minuten bei 500 °F (260 °C) aus und lassen Sie den Abschaltzyklus zu Ende kommen. Um den Grill auszuschalten, halten Sie die Zünd-/Abschalttaste oder das Auswahlrad drei Sekunden lang gedrückt, bis auf dem Display die Ausschaltanimation angezeigt wird.

HINWEIS: Leiten Sie nach jedem Garvorgang immer einen Abschaltzyklus ein.



Während der Grill abgeschaltet wird, läuft ein Countdown-Timer. Sie hören, dass der Lüfter weiterläuft.

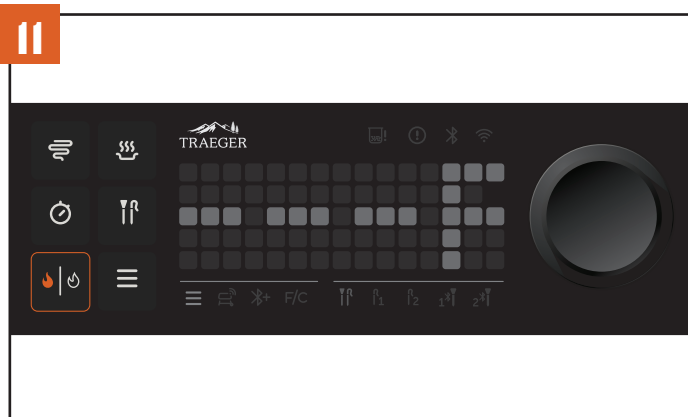

Nachdem dieser Countdown abgelaufen ist, ist der Abschaltzyklus abgeschlossen.

HINWEIS: Es ist normal, dass sich nach dem Einbrennen Asche auf der Tropfschale und/oder den Grillrosten bildet. Wischen Sie vor dem ersten Grillen einfach die Asche vom Grillrost ab.

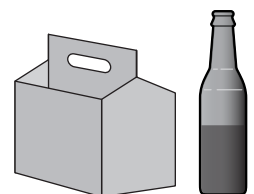

SO GRILLEN SIE AUF IHREM TRAEGER



1 Schalten Sie bei geschlossenem Deckel den Hauptschalter auf der Rückseite des Förderschneckengehäuses EIN (I). Drücken Sie das Auswahrad oder tippen Sie auf die Zünd-/Ausschalttaste, um den Grill aus dem Ruhemodus zu holen. Beim Einschalten des Grills wird nach einigen Sekunden ein Begrüßungsbildschirm angezeigt.

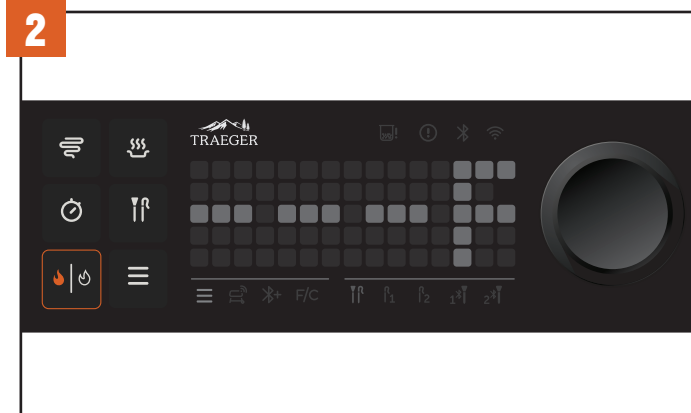

2 Die Punktmatrix zeigt drei Striche und F oder C an. Dies ist der Startbildschirm, wenn der Grill im Leerlauf ist. Sie können die Grilltemperatur direkt auf diesem Bildschirm einstellen.

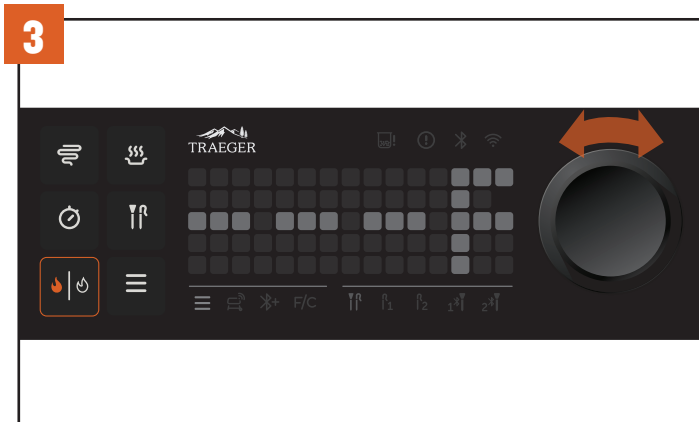

3 Um eine Temperatur einzustellen, drehen Sie das Auswahrad nach rechts, um die Temperatur zu erhöhen, oder nach links, um die Temperatur zu verringern.

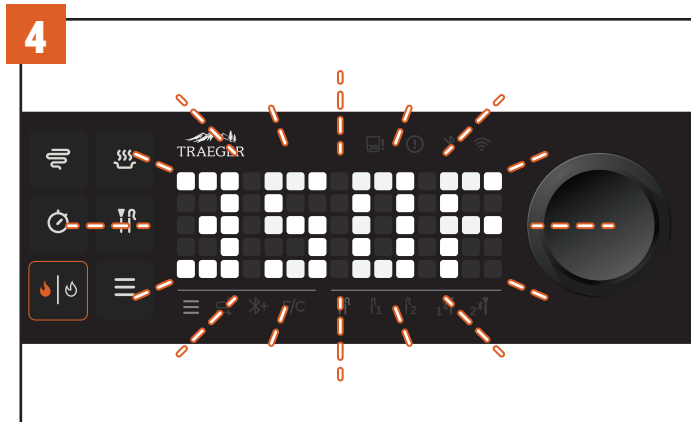

4 Die ausgewählte Temperatur blinkt.

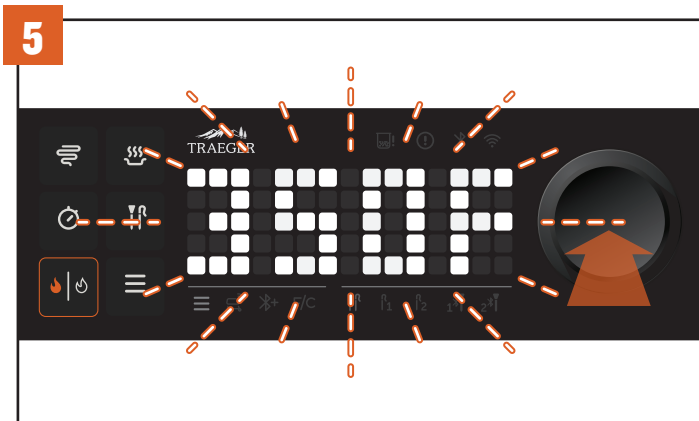

5 Während die Temperatur blinkt, drücken Sie auf die Mitte des Auswahrrads, um die gewünschte Temperatur auszuwählen.

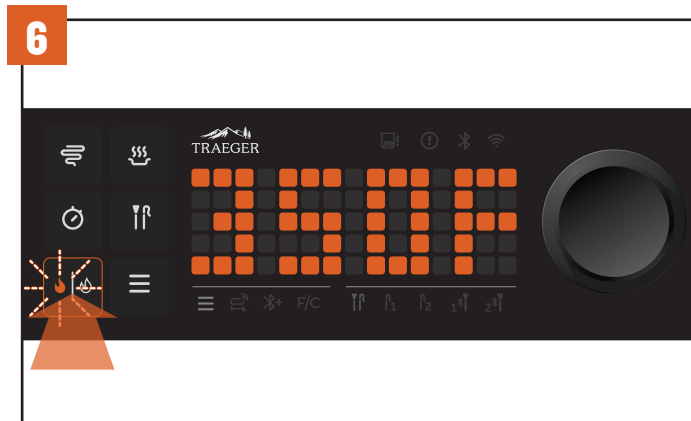

6 Nach Auswahl der Temperatur ändert sich die Temperaturanzeige von Weiß auf Orange und zeigt damit an, dass die ausgewählte Temperatur nun eingestellt ist. Die Zünd-/Ausschalttaste blinkt jetzt. Tippen Sie auf diese Taste, um den Grill zu zünden. Der Grill wird damit gezündet und heizt automatisch vor, um die eingestellte Temperatur zu erreichen.

SO GRILLEN SIE AUF IHREM TRAEGER (FORTS.)

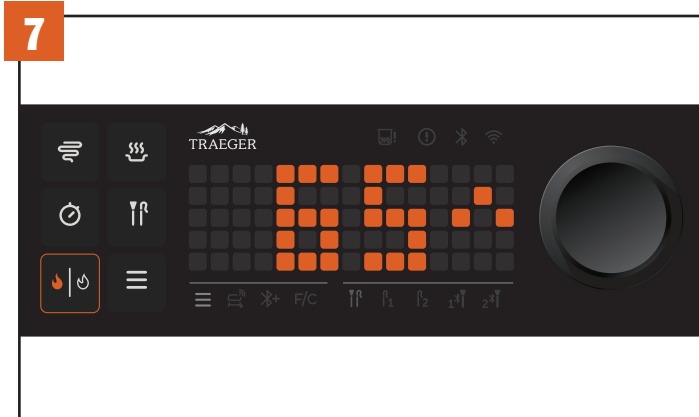

Während der Grill vorheizt, zeigt die Steuerung neben der Temperatur eine animierte Flamme an, die den Vorheizmodus zu erkennen gibt. Die aktuelle Temperatur steigt in 5-Grad-Schritten, während der Grill aufheizt.



Wenn der Grill die eingestellte Temperatur erreicht hat, verschwindet die Vorheizpfeilanimation vom Bedienfeld und die aktuelle Temperatur schwankt von nun an um $\pm 25^{\circ}\text{F}$ ($\pm 14^{\circ}\text{C}$) um die eingestellte Temperatur. Diese kleinen Temperaturschwankungen sind bei der täglichen Verwendung eines Holzpelletgrills für den täglichen Gebrauch völlig normal und eine natürliche Folge des Anfachens und Überwachens der Flamme. Öffnen Sie den Deckel nicht und nehmen Sie keine Temperaturänderungen vor, bevor die Einstelltemperatur erreicht ist.

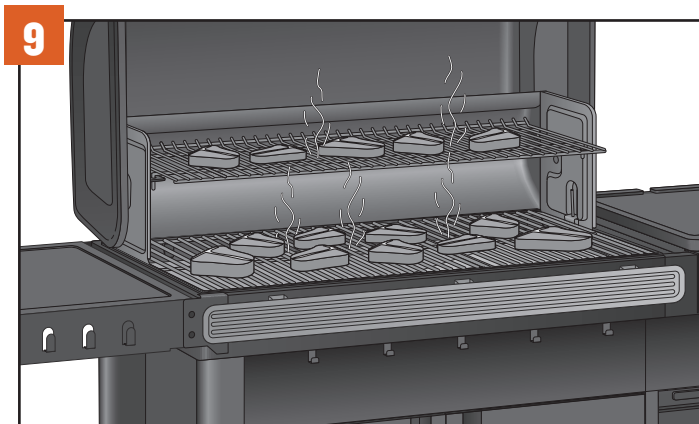

Jetzt können Sie Grillgut auflegen und mit dem Kochen beginnen.

TIPPS:

- Der Deckel sollte beim Vorheizen geschlossen bleiben, damit der Grill die eingestellte Temperatur erreichen kann.
- Warten Sie, bis der Vorheizzyklus abgeschlossen ist, bevor Sie mit der Zubereitung Ihrer Speisen beginnen. Das Öffnen des Deckels vor Erreichen der gewünschten Temperatur kann dazu führen, dass Sie keine optimalen Kochergebnisse erzielen.
- Wenn Sie das Grillgut zu früh auflegen, kann es sein, dass der Grill länger als gewöhnlich braucht, um die gewünschte Temperatur zu erreichen.
- **Traeger Woodridge Grills bieten eine Echtzeit-Temperaturanzeige in Fünf-Grad-Schritten und Sie sollten mit Temperaturschwankungen rechnen.**



PROFI-TIPP: Das Garen auf die gewünschte Kerntemperatur ist das Geheimnis für hervorragende Ergebnisse.



NOTIZEN



