



ASSEMBLY GUIDE

WOODRIDGE WOOD PELLET GRILL



**SCAN FOR
STEP BY STEP
ANIMATED
INSTRUCTIONS**

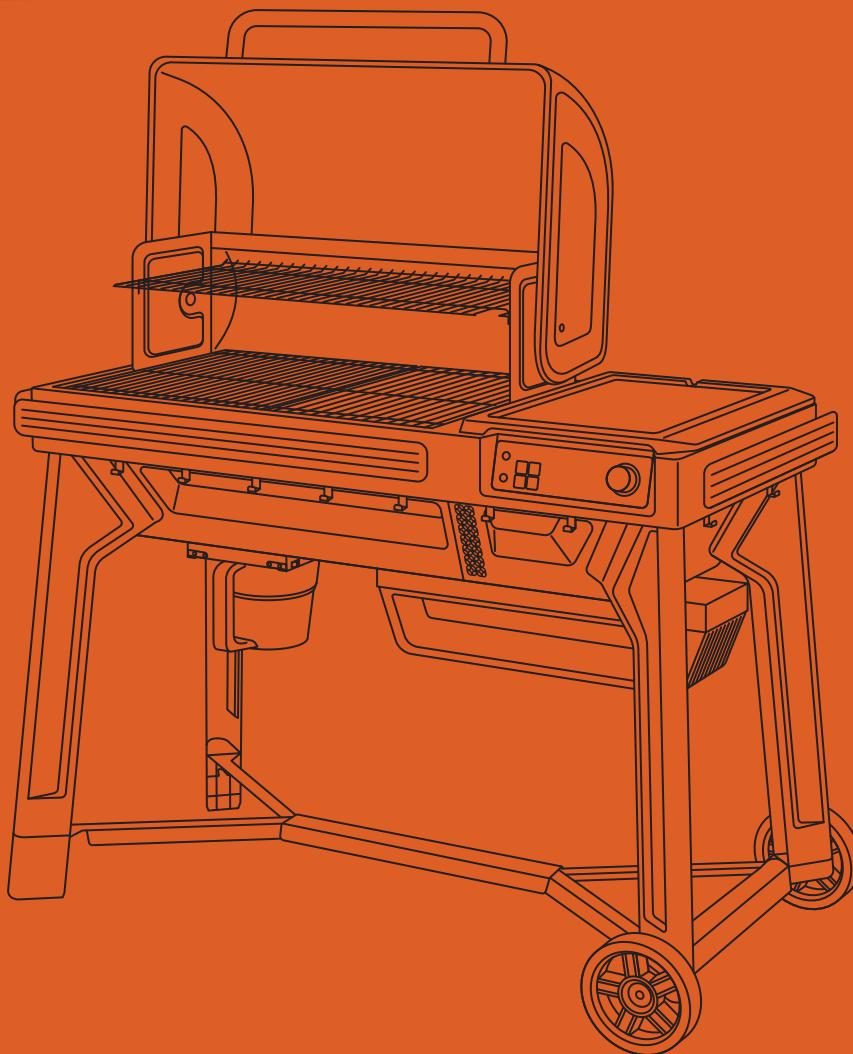

A MAJOR CAUSE OF FIRES IS FAILURE TO MAINTAIN REQUIRED CLEARANCES (AIR SPACES) TO COMBUSTIBLE MATERIALS. IT IS OF UTMOST IMPORTANCE THAT THIS PRODUCT BE INSTALLED ONLY IN ACCORDANCE WITH THESE INSTRUCTIONS.

IMPORTANT: RETAIN FOR FUTURE REFERENCE. READ CAREFULLY.

T18983

©2025 TRAEGER PELLET GRILLS LLC.
ALL RIGHTS RESERVED.

TRAERER PELLET GRILLS LLC

533 South 400 West
Salt Lake City, UT 84101

TRAERER.COM

BEFORE YOU BUILD

PLEASE READ THIS ASSEMBLY GUIDE AND YOUR OWNER'S MANUAL BEFORE INSTALLATION AND USE OF YOUR TRAEGER GRILL. FAILURE TO FOLLOW THE INSTRUCTIONS IN THIS ASSEMBLY GUIDE AND YOUR OWNER'S MANUAL COULD RESULT IN PROPERTY DAMAGE, BODILY INJURY, OR EVEN DEATH.

When using your grill, maintain a MINIMUM distance of 50.8 cm (20 inches) from the grill to any nearby combustibles, including wooden railings, home siding, window frames, furniture, trees, trash receptacles, etc. Do not install or operate this grill on combustible floors or surfaces, indoors, or under a combustible ceiling or overhang. Read the Owner's Manual for additional instructions and warnings.

SETUP SPACE



PRO TIP: Build on the bottom tray of the shipping box to help prevent scratches.

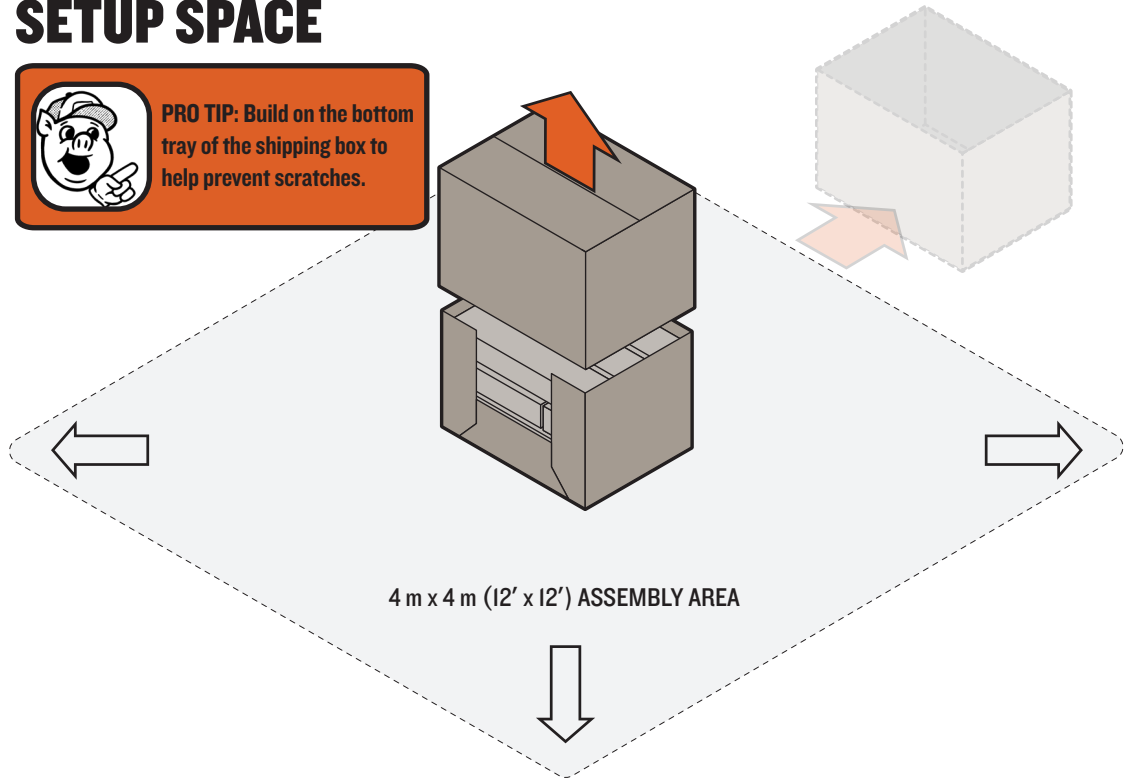

PRO TIP: We recommend assembling your grill with two people.

SETUP

Once all components are unpacked, arrange pieces onto the bottom tray of the shipping box.

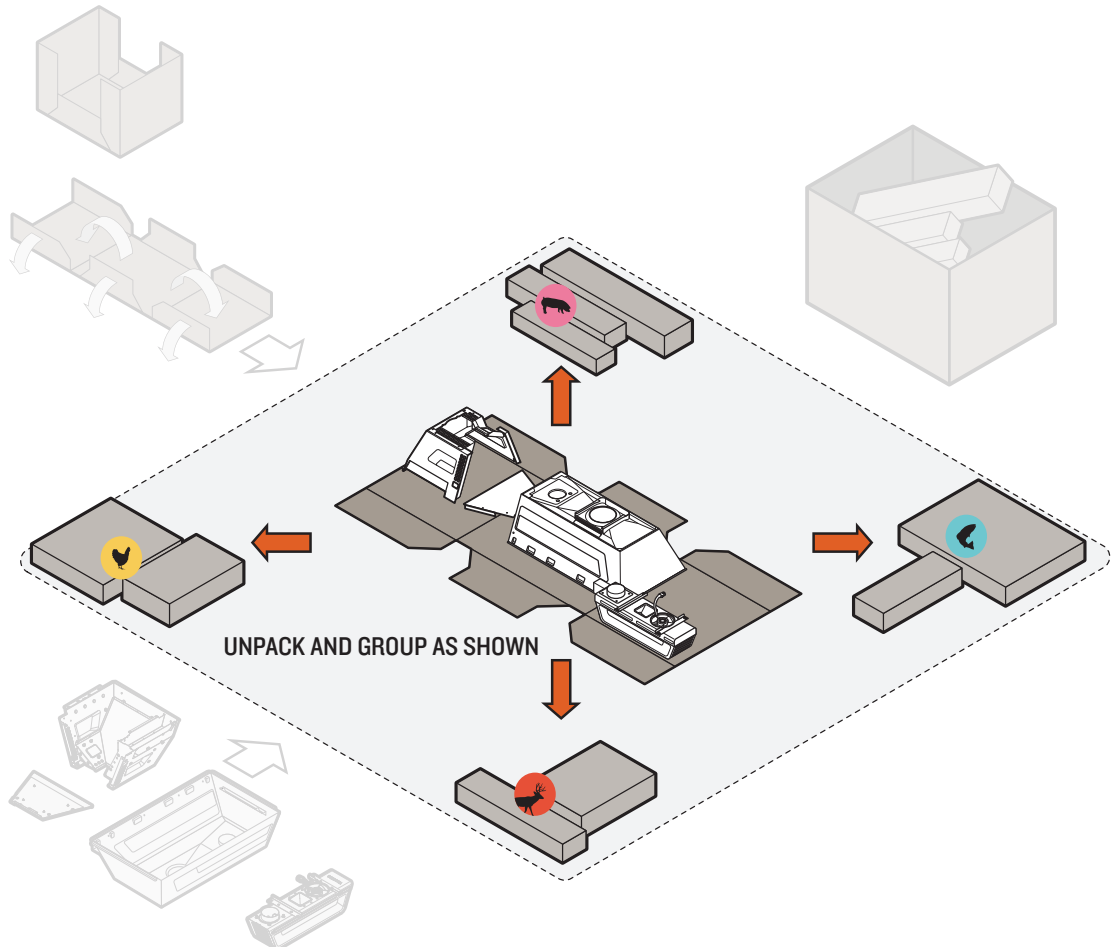

GROUP BOXES BY THEIR IDENTIFYING SYMBOLS, SHOWN BELOW:



COMPARTMENTS & LEGS



WHEELS & HOOVES



CONTROLS & SHELVING



LID & GRILL INTERNALS



HARDWARE (TOTAL QUANTITIES)

1:1 SCALE

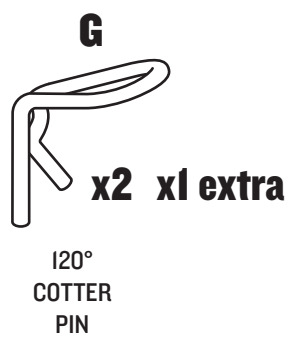
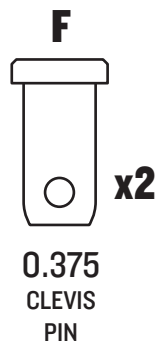
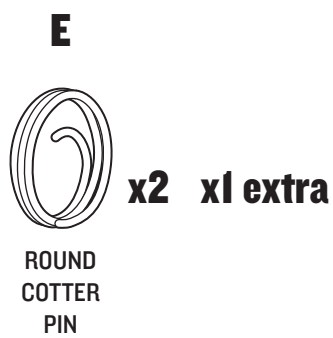
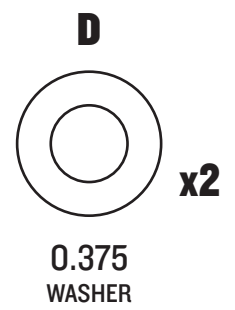
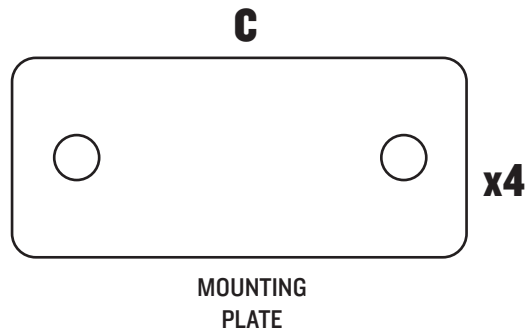
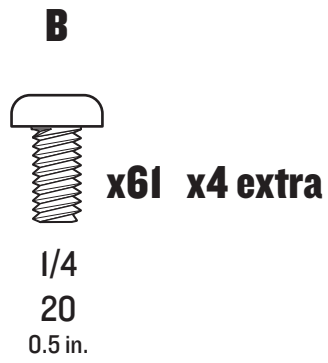
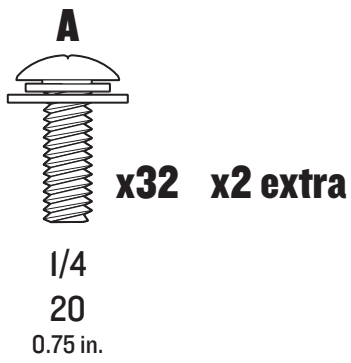



CHAPTERS

CHAPTER 1 – PAGE 5
COMPARTMENTS & LEGS

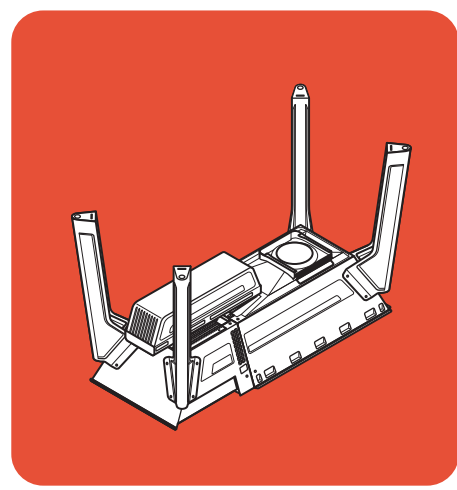

CHAPTER 2 – PAGE 13
WHEELS & HOOVES

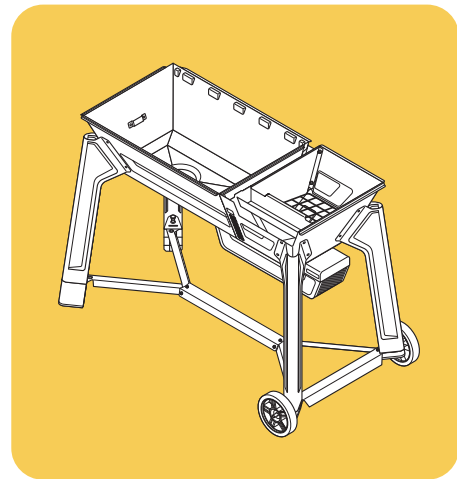
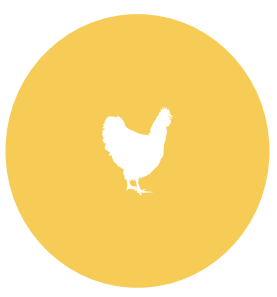

CHAPTER 3 – PAGE 19
CONTROLS & SHELVING

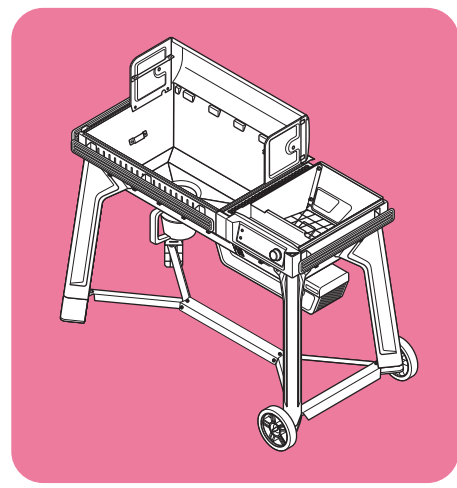

CHAPTER 4 – PAGE 31
LID & GRILL INTERNALS

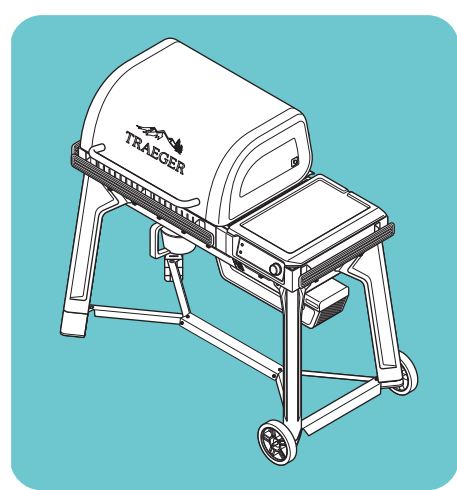

CHAPTER 1

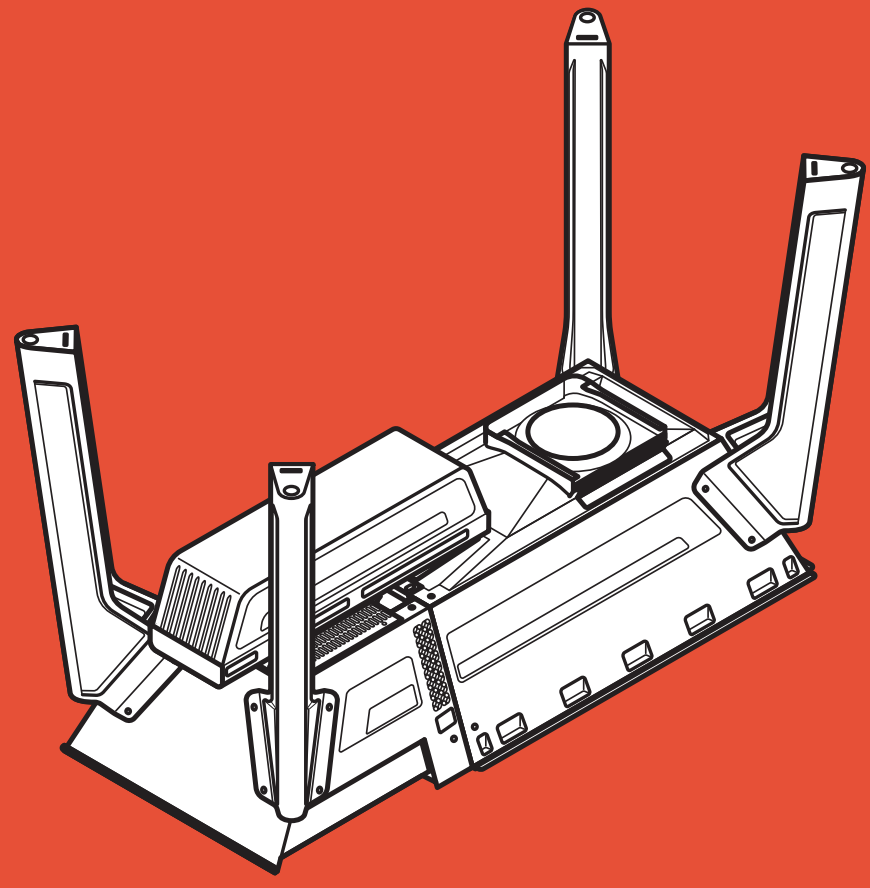

COMPARTMENTS & LEGS

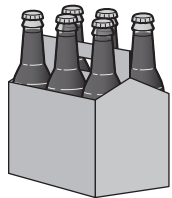
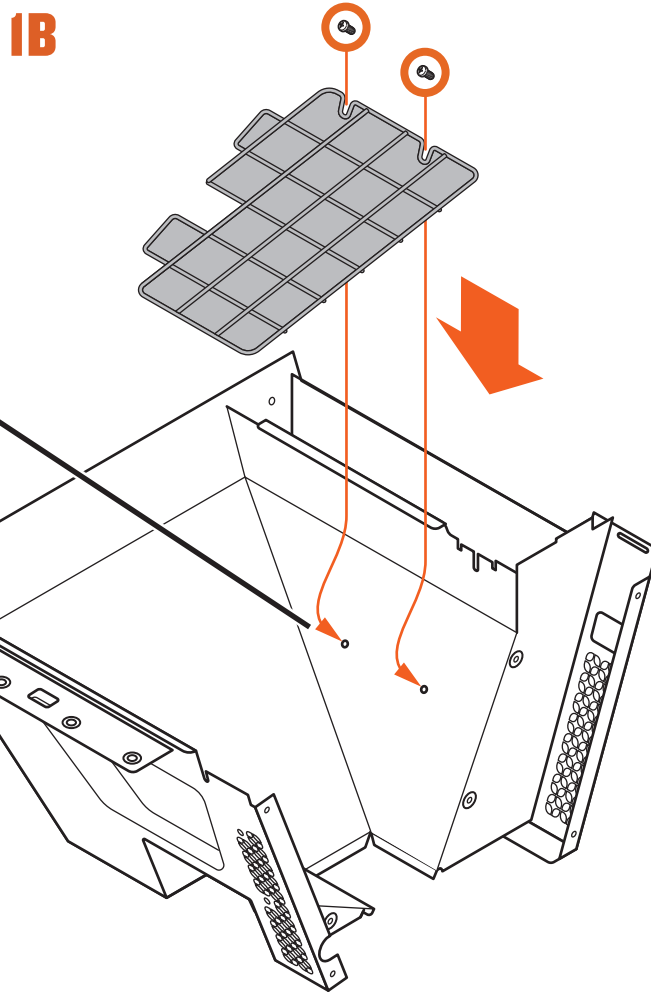
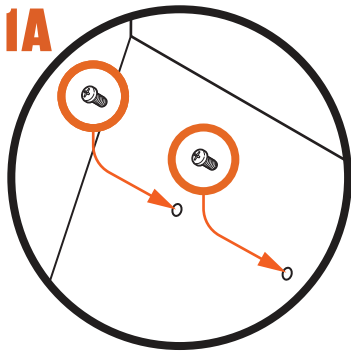
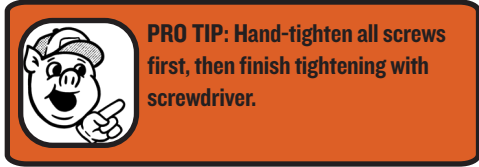
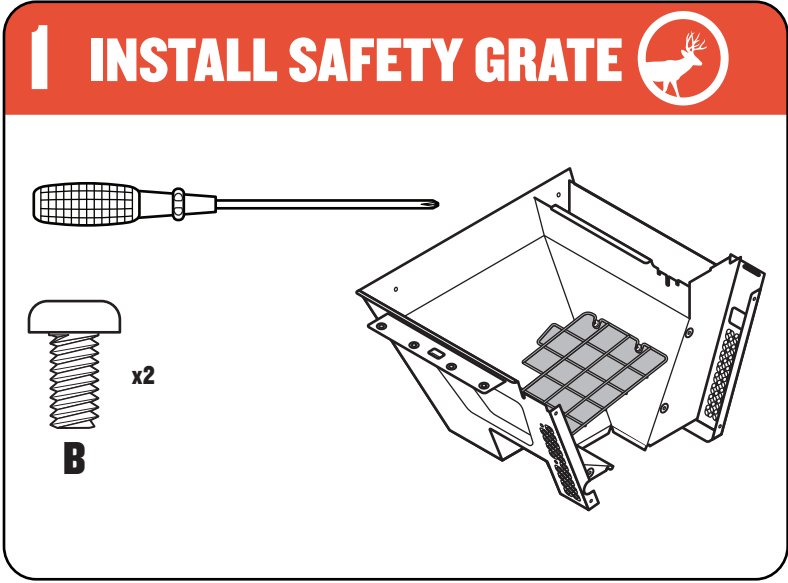
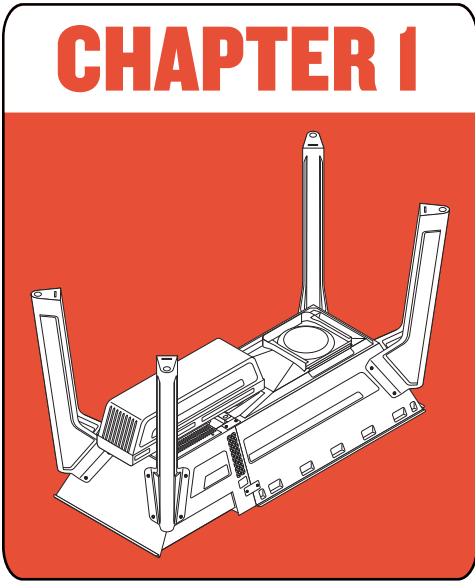



2 ASSEMBLE HOPPER

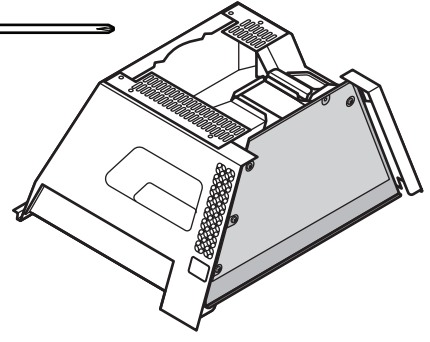
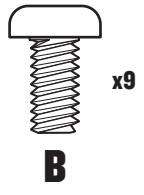
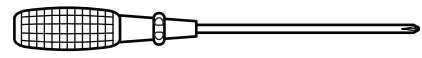

2A

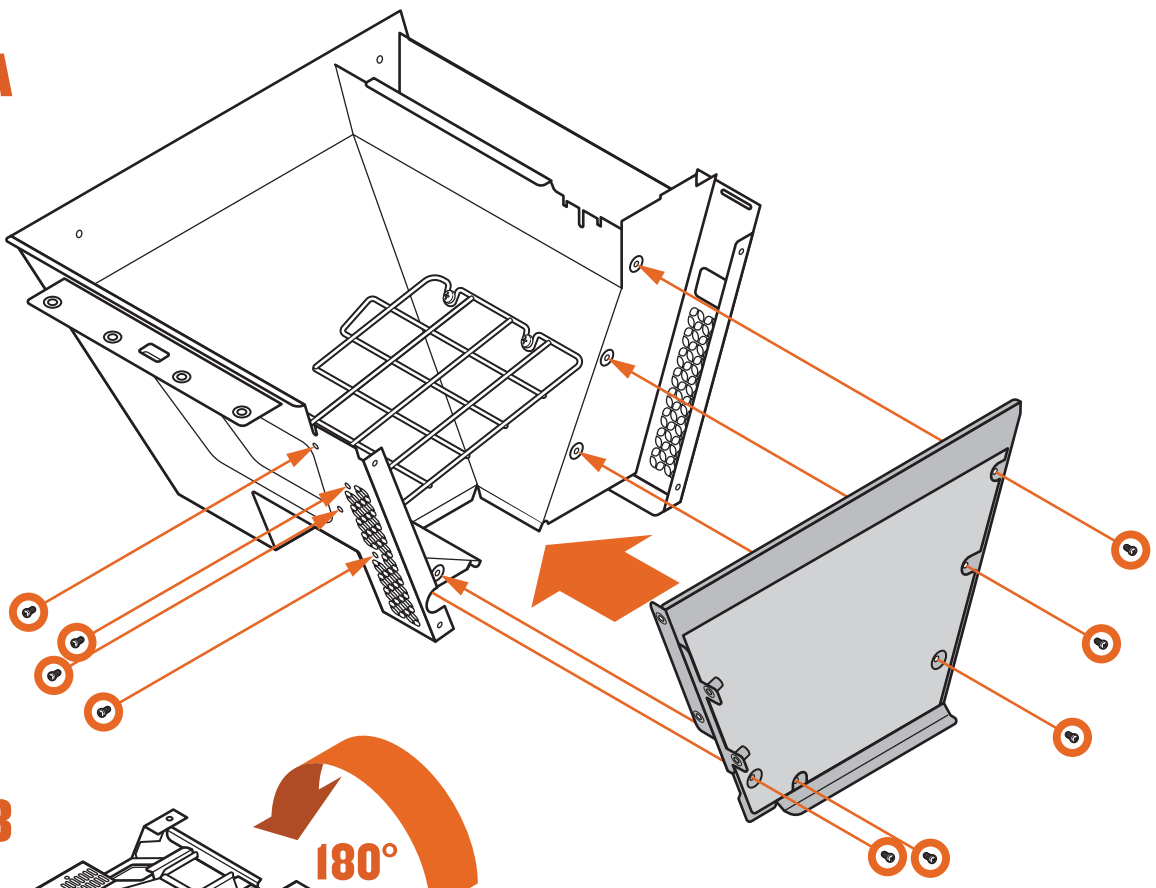

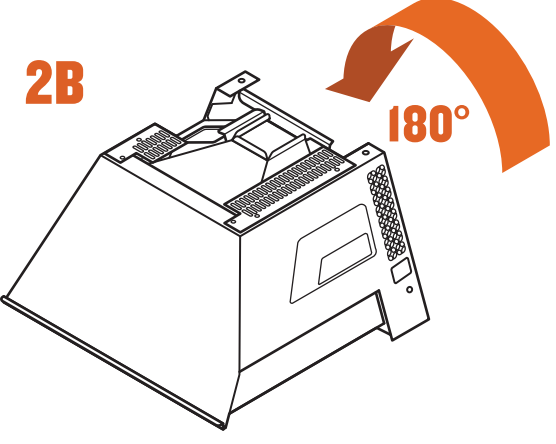

2B



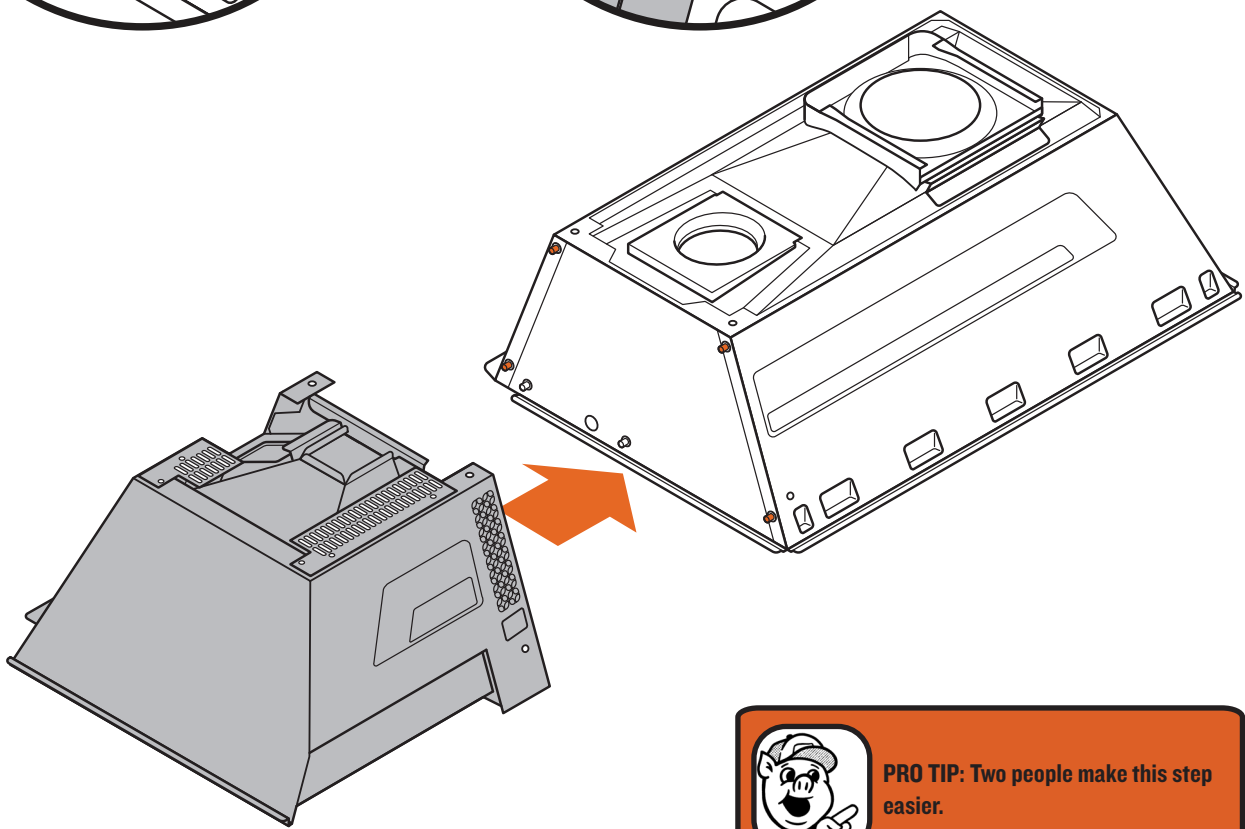
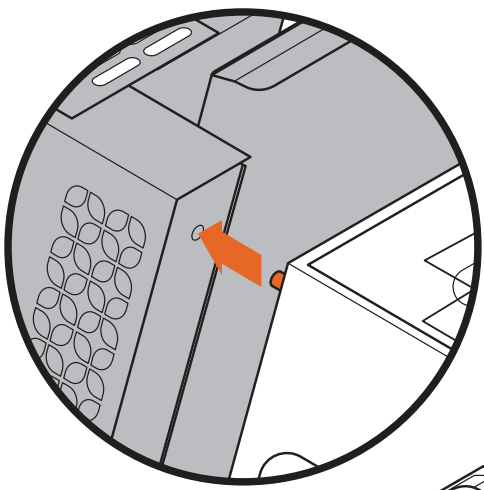
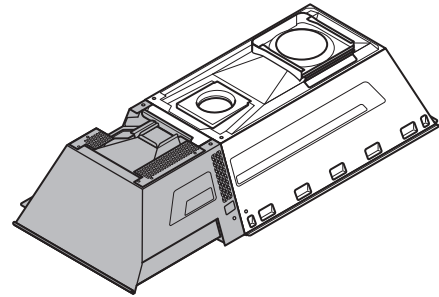

3A ATTACH HOPPER TO BODY



 **PRO TIP:** Two people make this step easier.





3B ATTACH HOPPER TO BODY

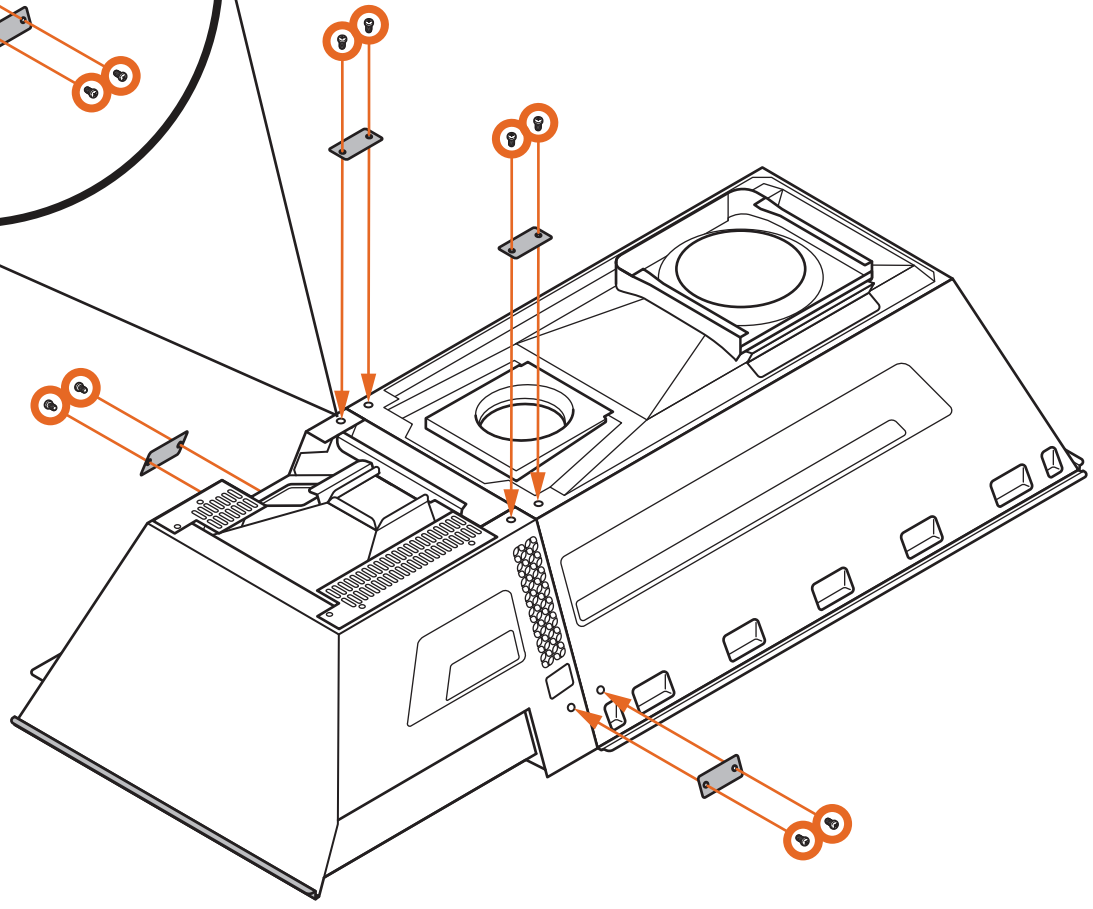
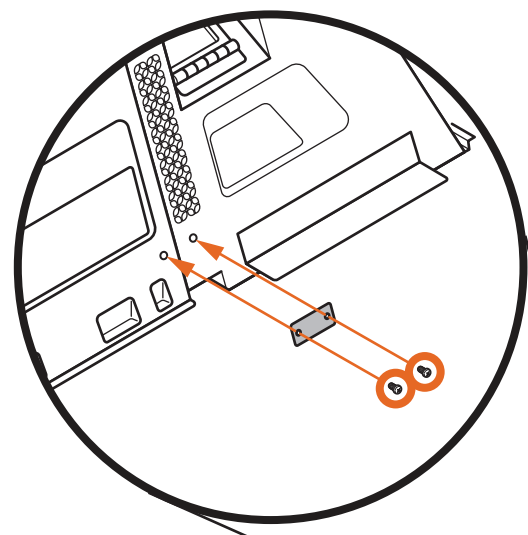
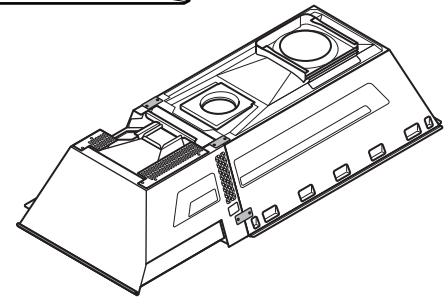
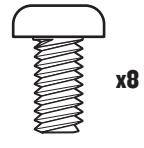
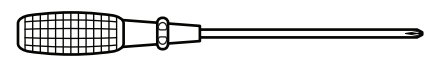



4 CONNECT AUGER BOX

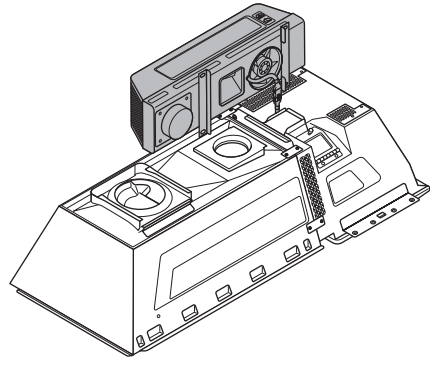
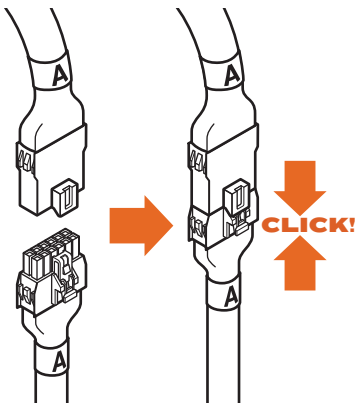

PRO TIP: Have a second person hold the auger box while you connect the cord.



PRO TIP: Don't forget to remove the twist tie and tape holding down the cord.

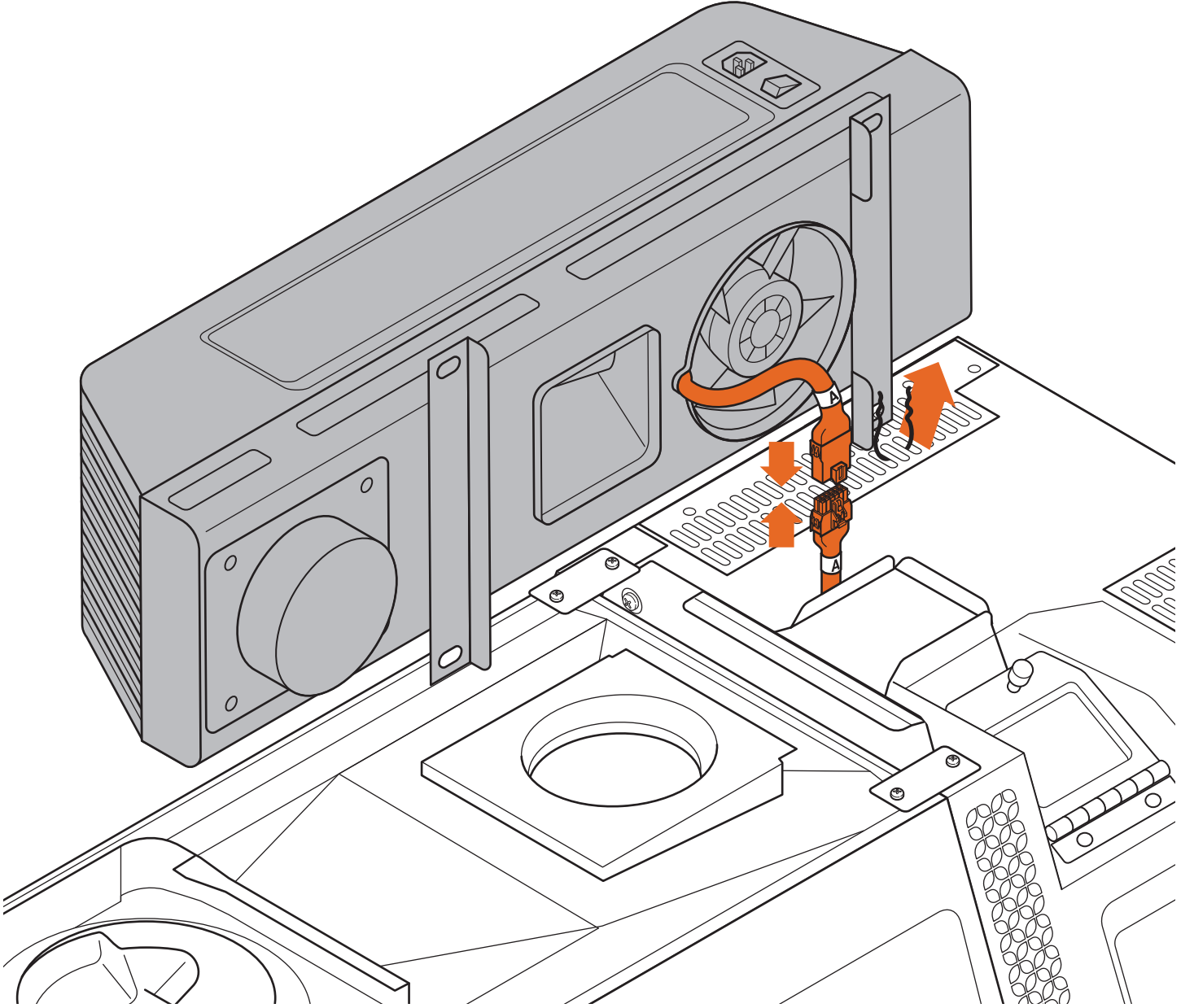



5 ATTACH AUGER BOX

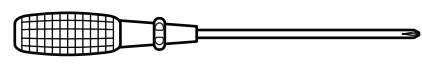

Use **THIS** screw now!

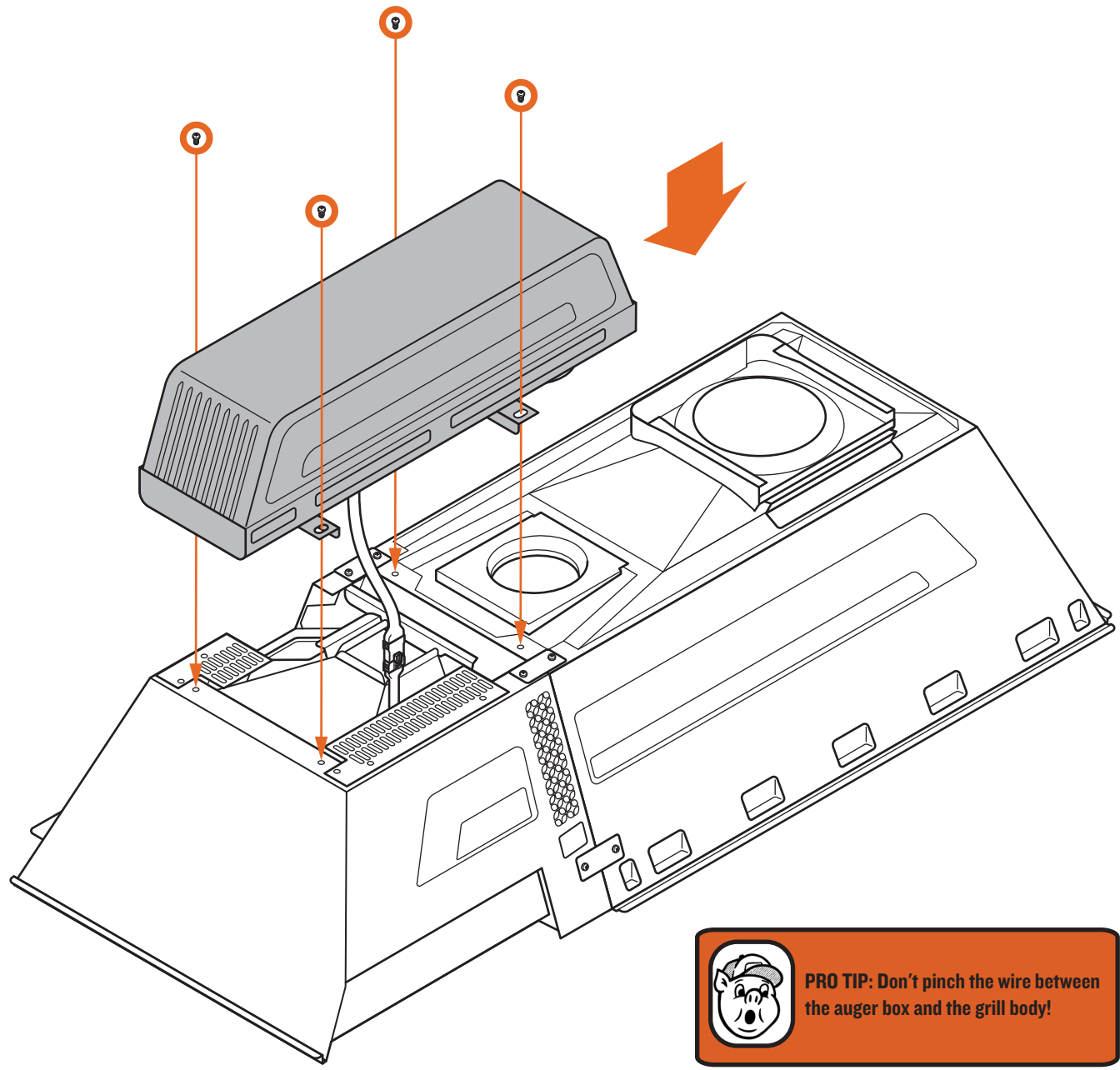
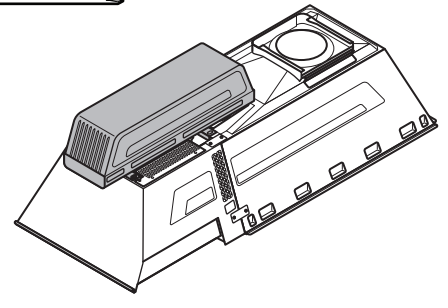
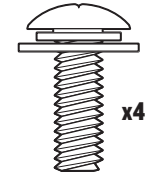

 **PRO TIP:** Don't pinch the wire between the auger box and the grill body!



6 ATTACH LEGS

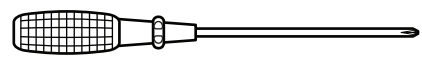

Use **THIS** screw again!

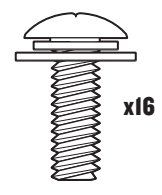

A

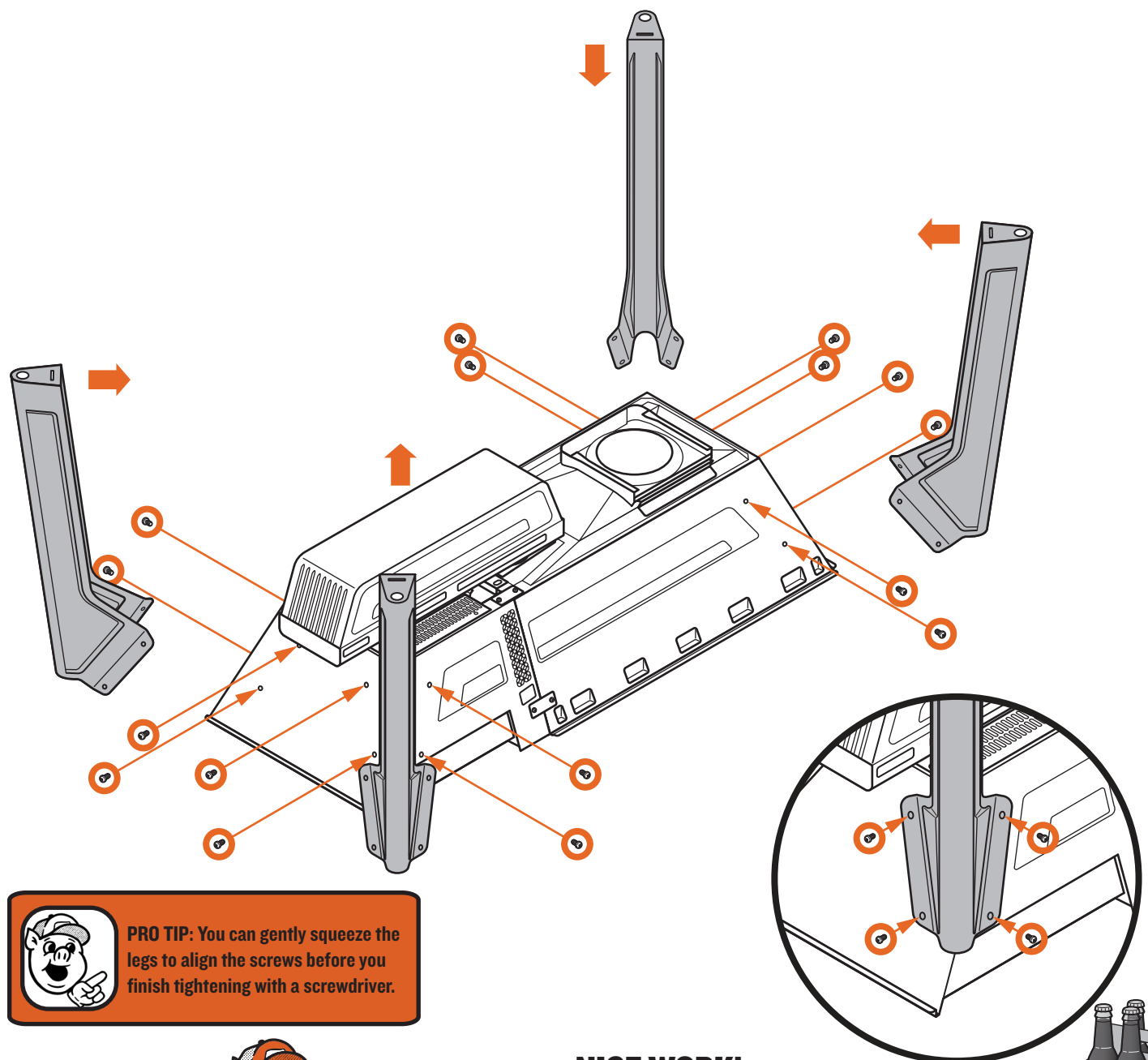
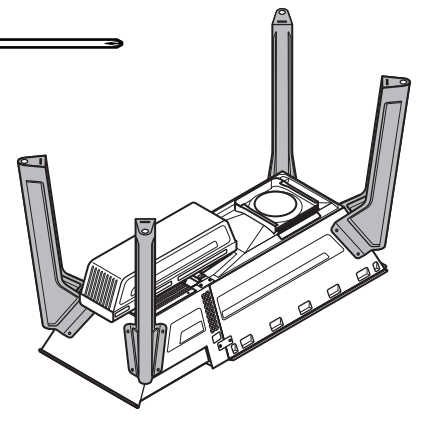

 **PRO TIP:** You can gently squeeze the legs to align the screws before you finish tightening with a screwdriver.

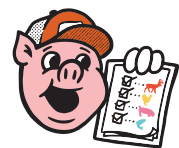

**NICE WORK!
CHAPTER I COMPLETE!**

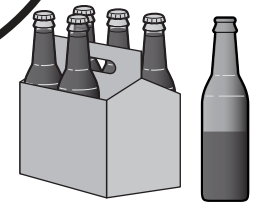

CHAPTER 2

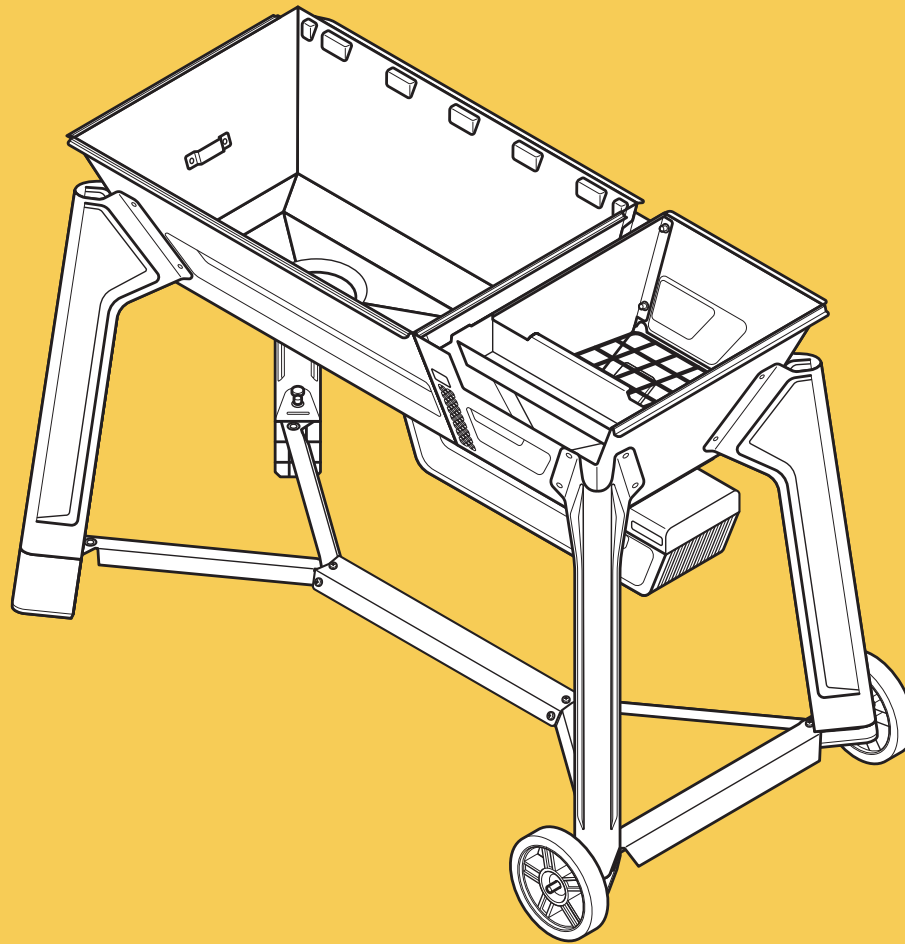

WHEELS & HOOVES

CHAPTER 2

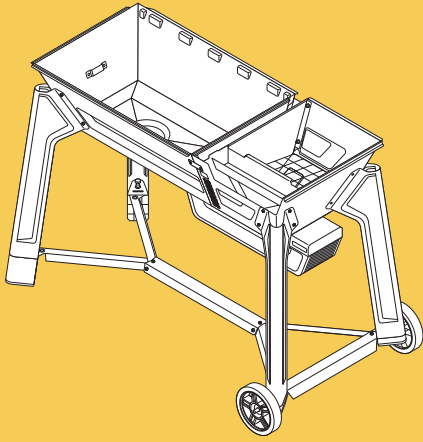

1 ASSEMBLE BRACE/AXLE COVER

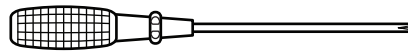

Use THIS screw again!

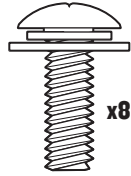

A

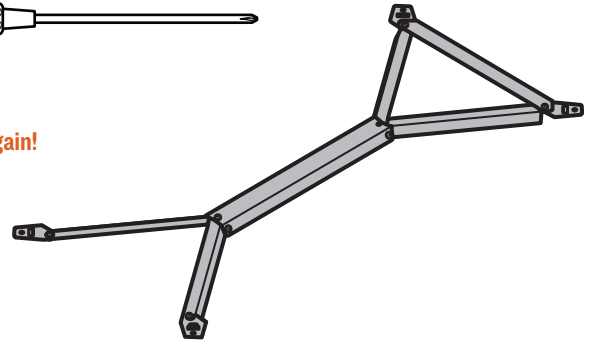

PRO TIP: Hand-tighten all screws first, then finish tightening with screwdriver.

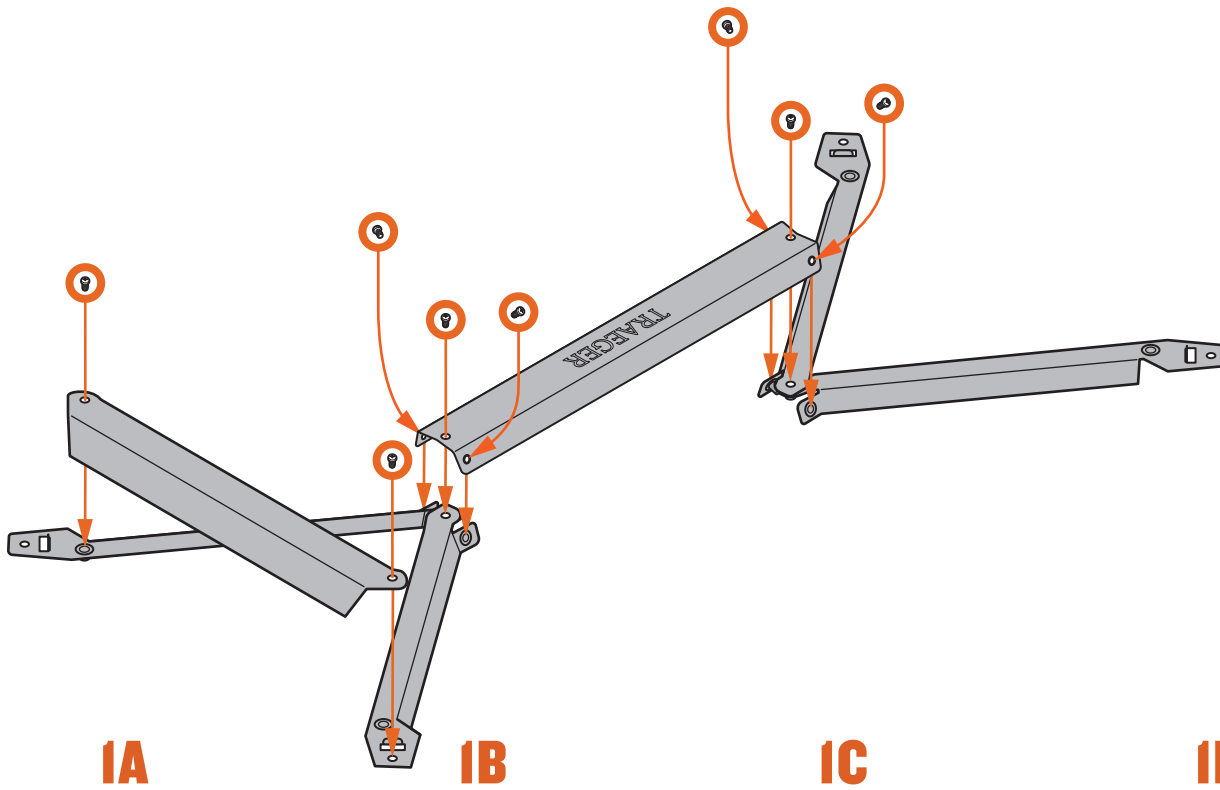

IA

IB

IC

ID

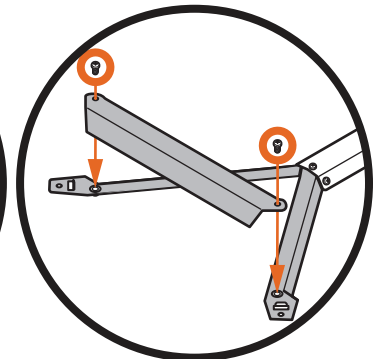
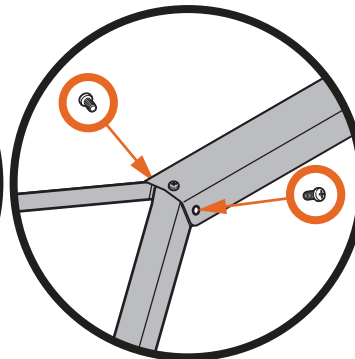
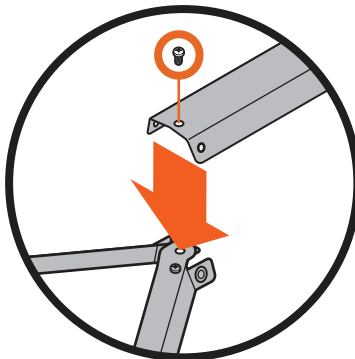
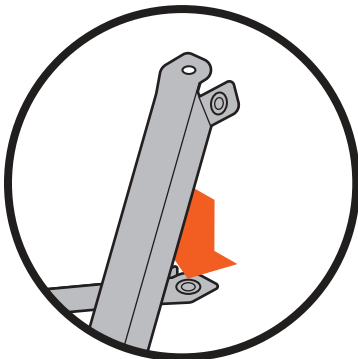



2 ATTACH BRACE/AXLE COVER

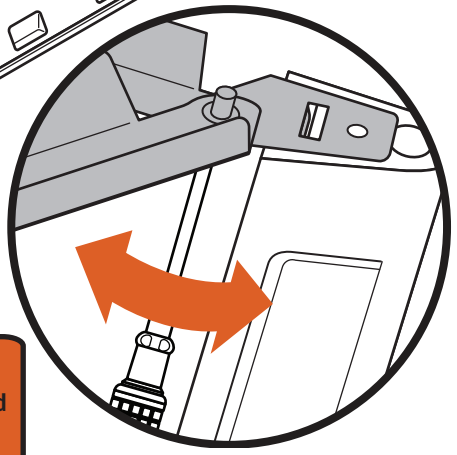
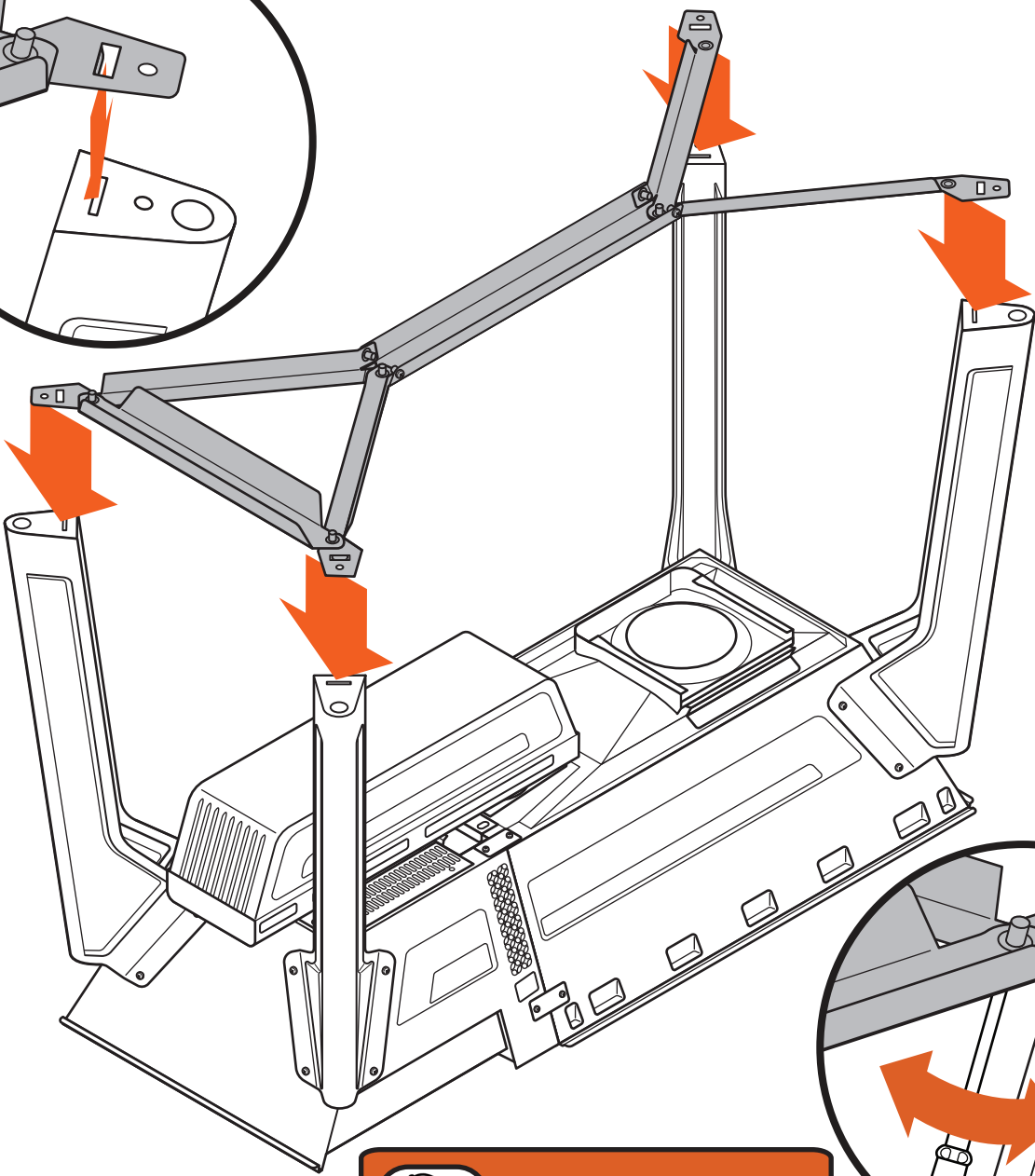
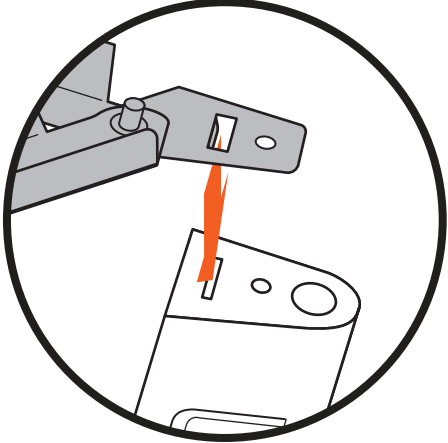
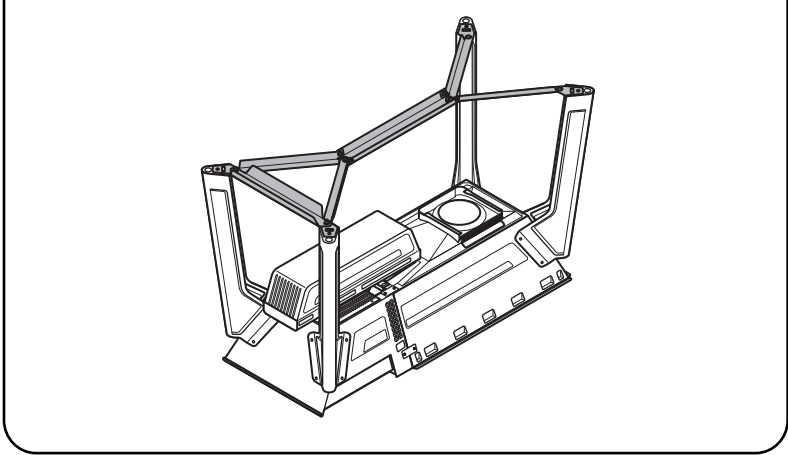
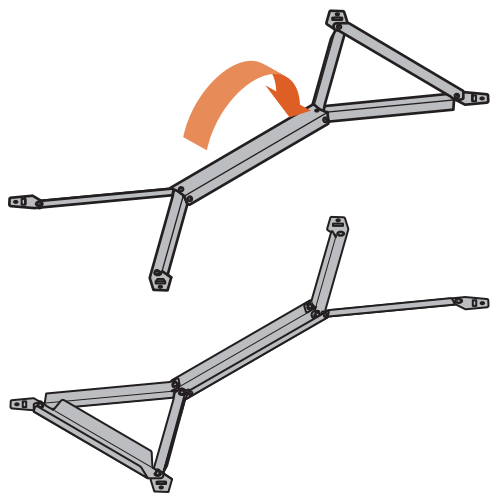

 **PRO TIP:** To adjust brace, loosen and tighten screws as needed.

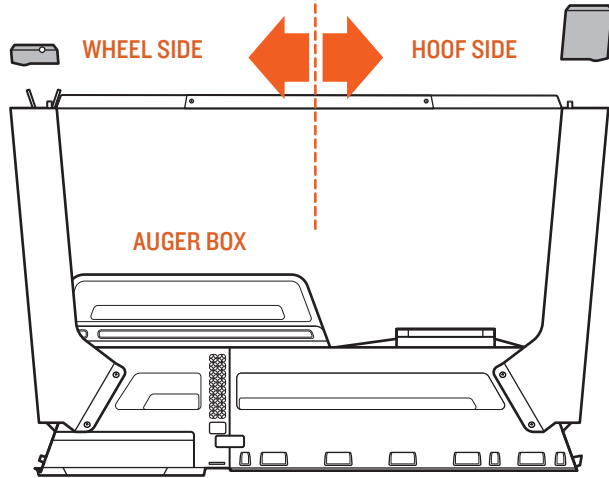

3 ATTACH WHEEL HOOVES

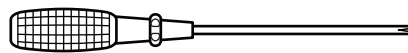

Use THIS screw again!

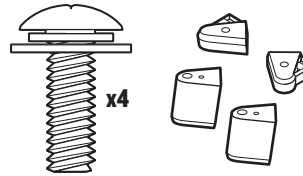

A

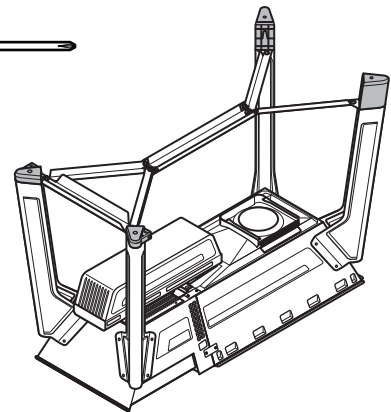

PRO TIP: This step uses screw A. Load it into the hoof by hand, then tighten it with the screwdriver.

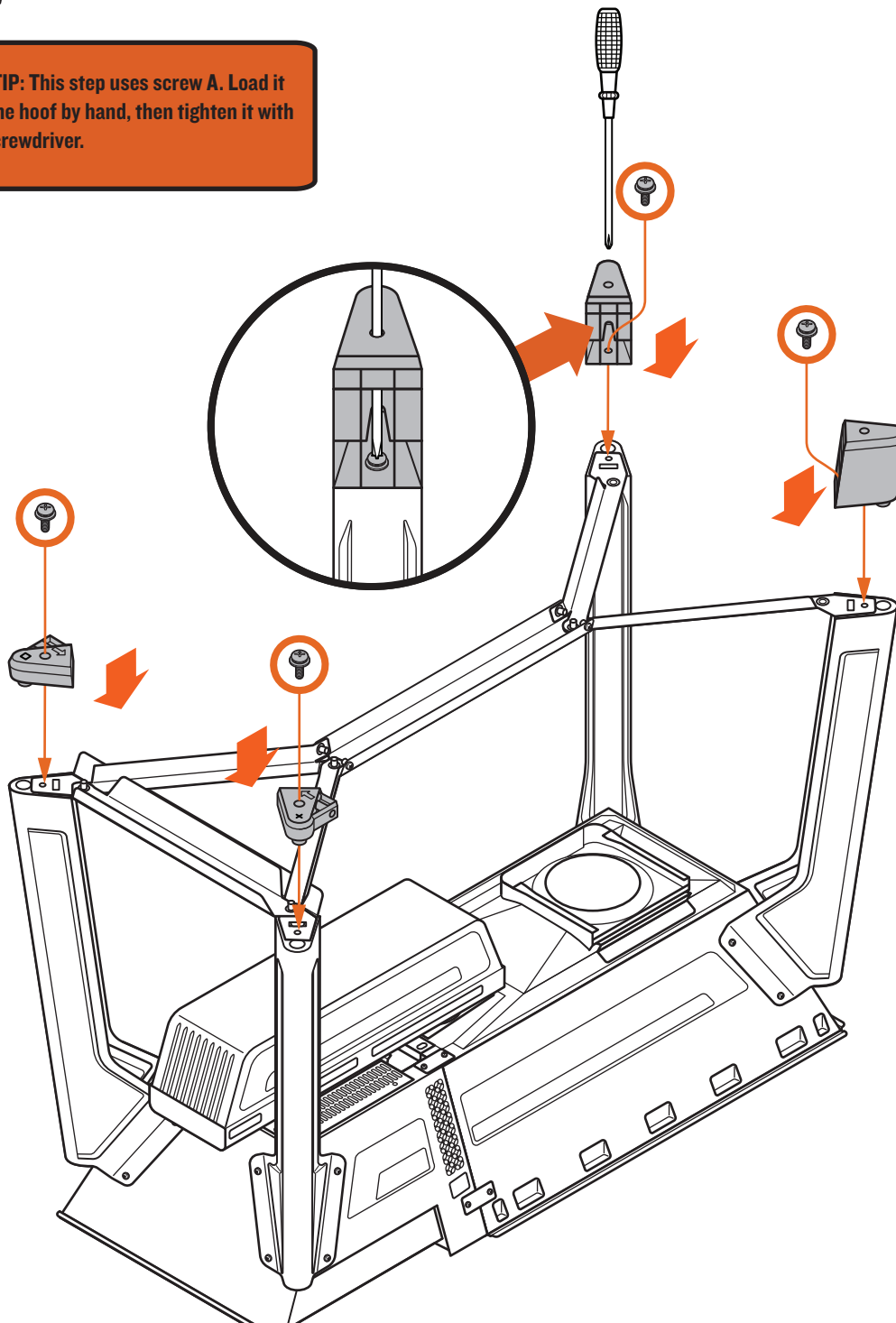



4 ASSEMBLE WHEELS



x2

E

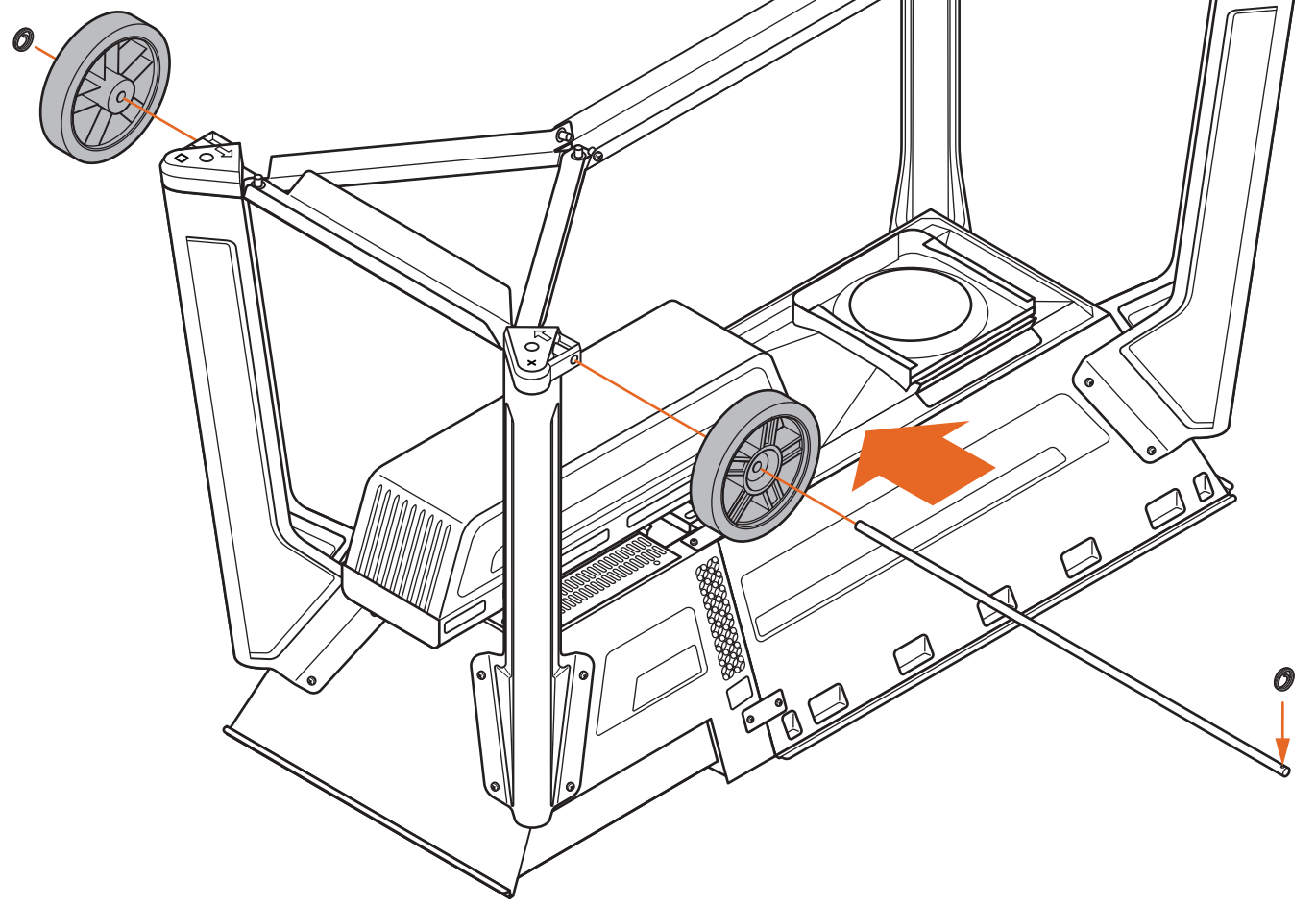
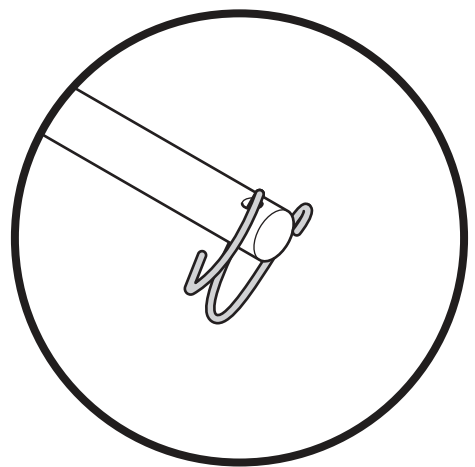
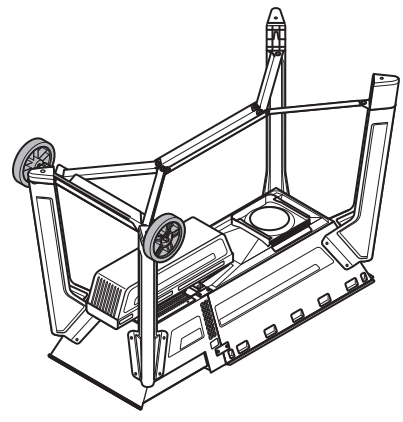



 **PRO TIP:** Have a second person help lift and rotate the grill.

5 FLIP GRILL OVER

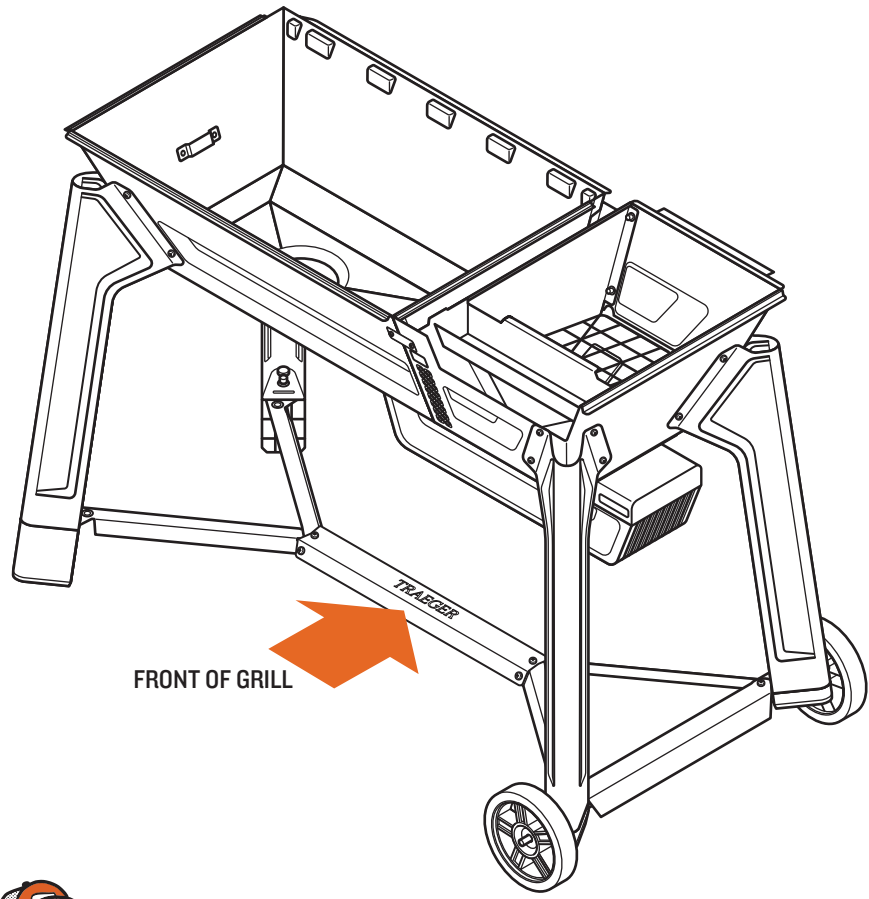
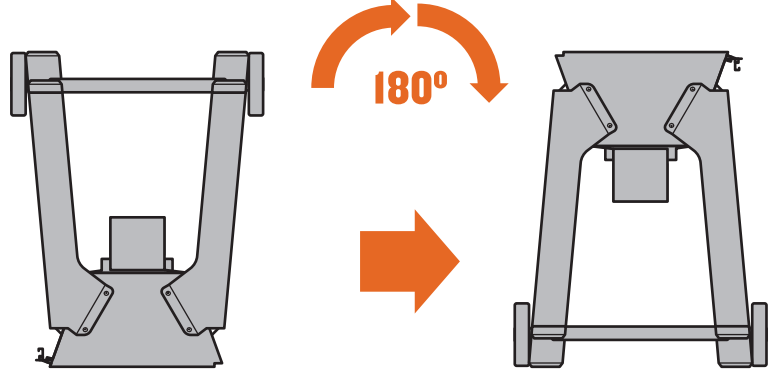
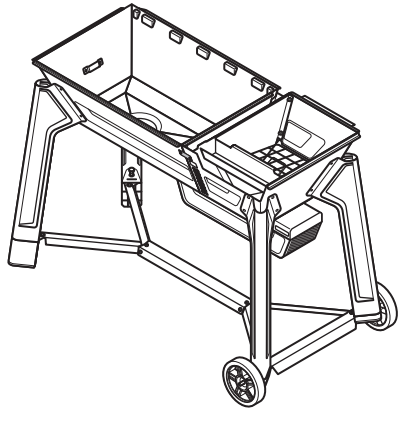

**NICE WORK!
CHAPTER 2 COMPLETE!**

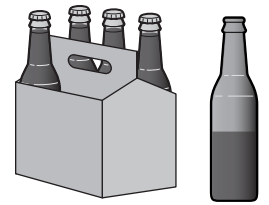

CHAPTER 3

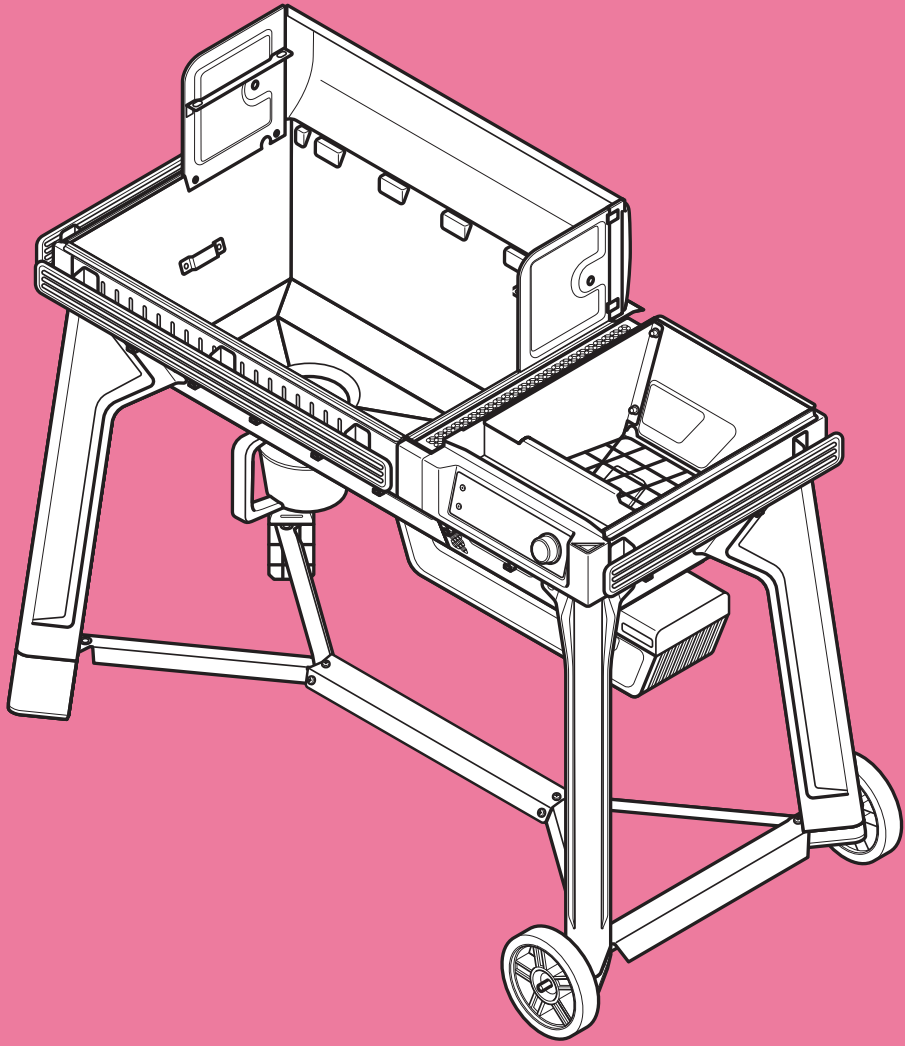

CONTROLS & SHELVING



CHAPTER 3

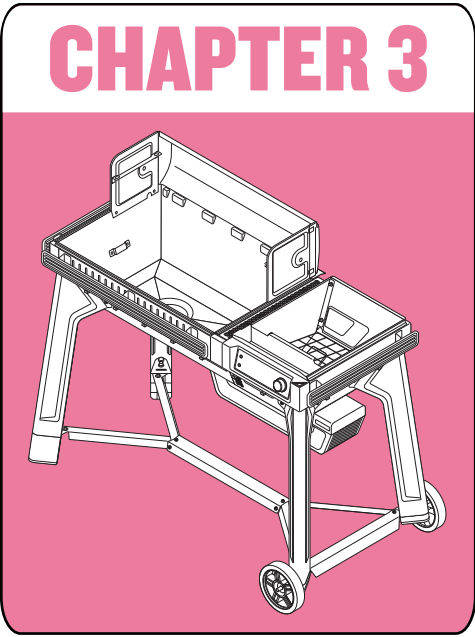

1 BUILD P.A.L. RAILS

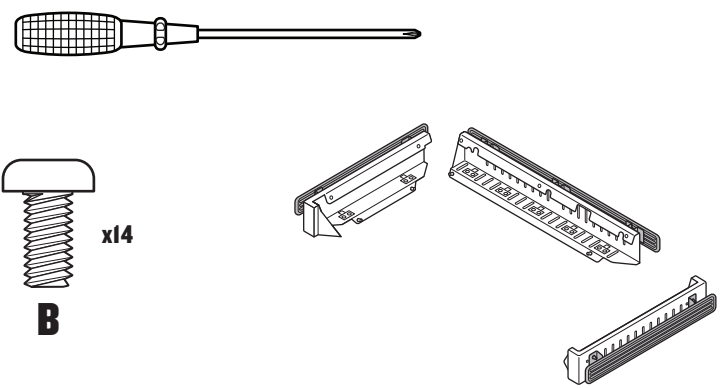

 **PRO TIP:** Hand-tighten all screws first, then finish tightening with screwdriver.

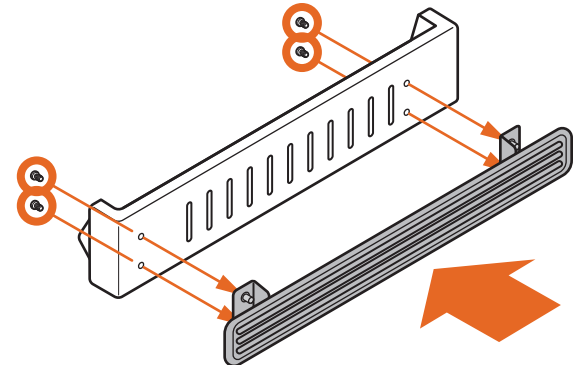
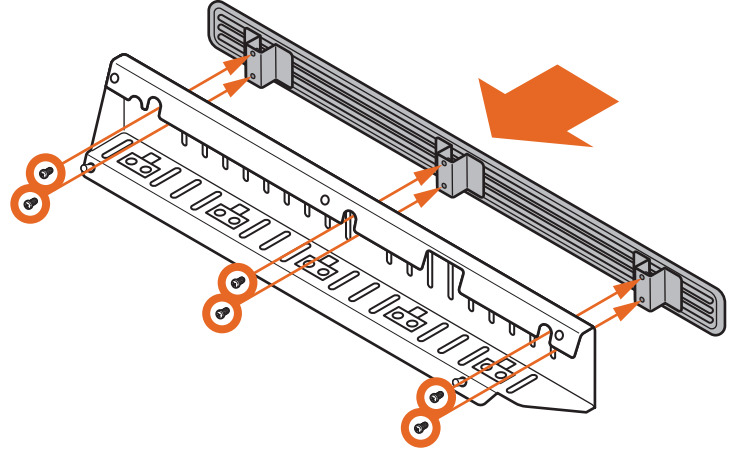
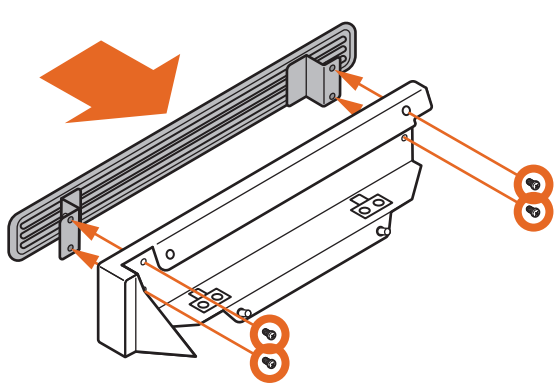



PRO TIP: This step can be tricky. Scan our QR code to access video animations for assembly. Jump to Chapter 3, Step 2 for a video.

PRO TIP: To prevent hardware from falling into the auger box, lay this manual on top of the grate.



2A ATTACH P.A.L. TRIM



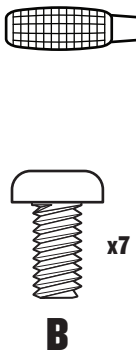
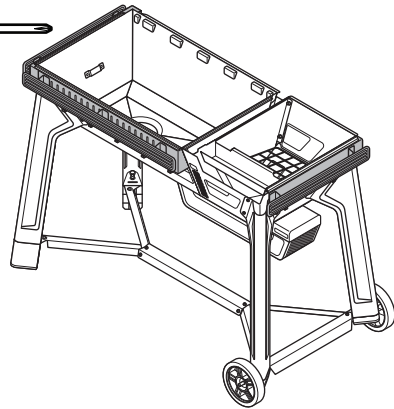
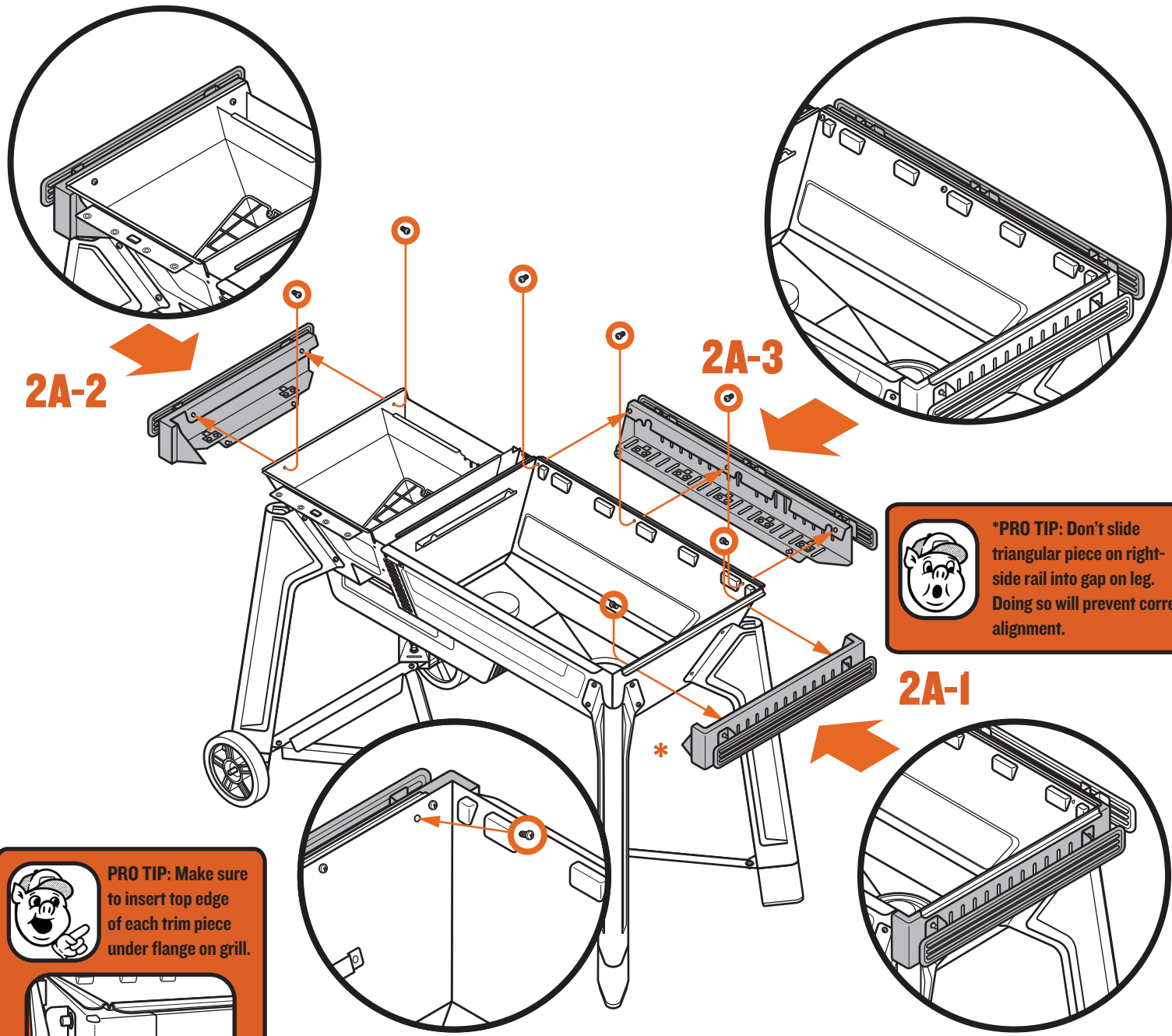

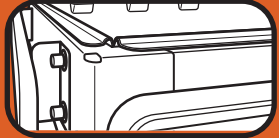
PRO TIP: Make sure to insert top edge of each trim piece under flange on grill.



2B SECURE P.A.L. TRIM

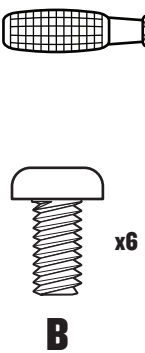

x6

B

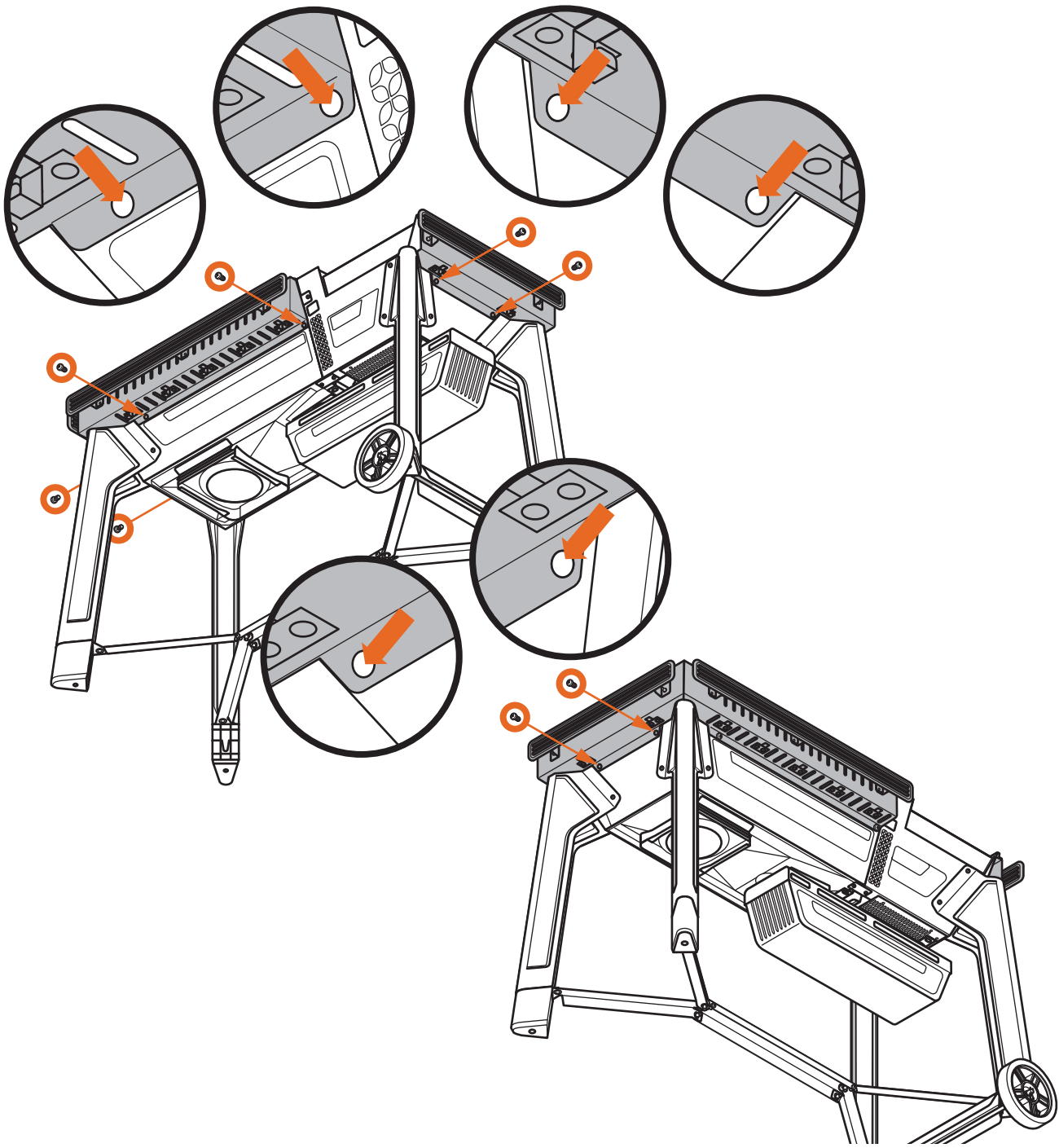
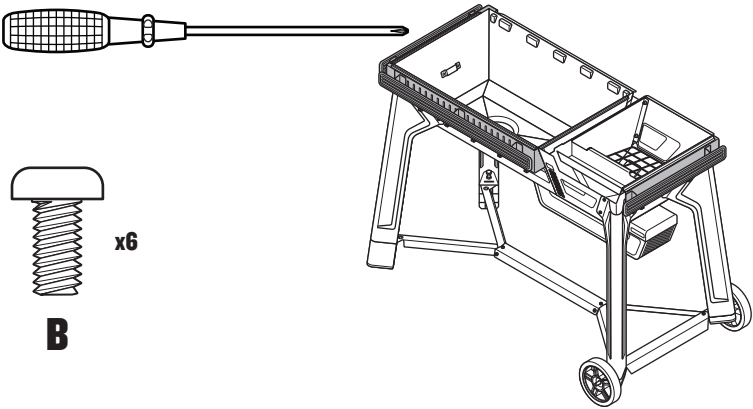



 **PRO TIP:** This step requires no hardware.

3 ASSEMBLE BACKSPLASH

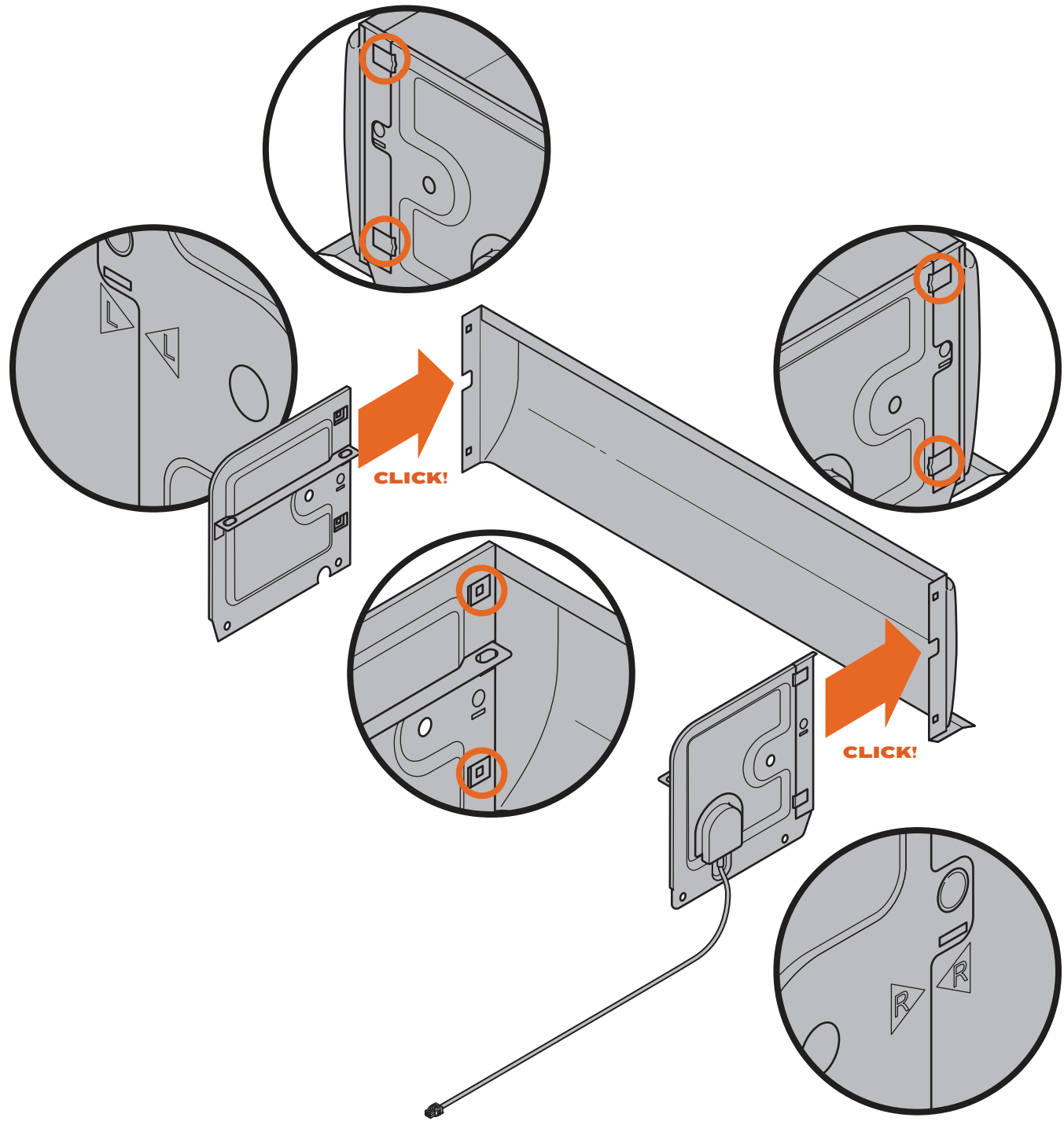
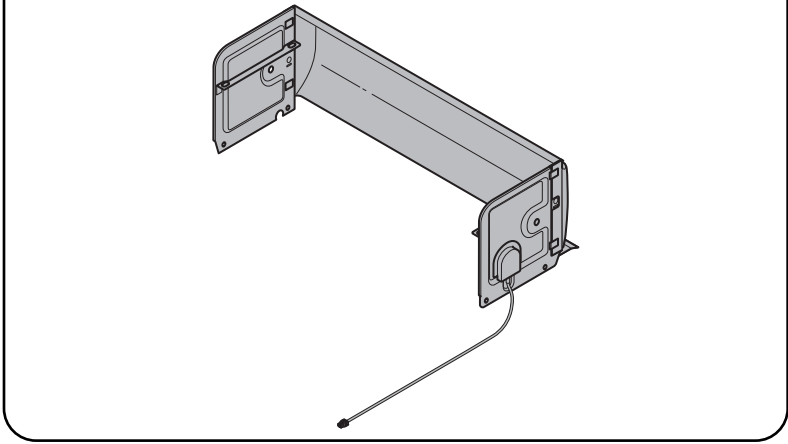



PRO TIP: Don't pinch the wire between the backsplash and the grill body! Also, slide the wire through the openings carefully to prevent damage!

4 ROUTE BACKSPLASH WIRING

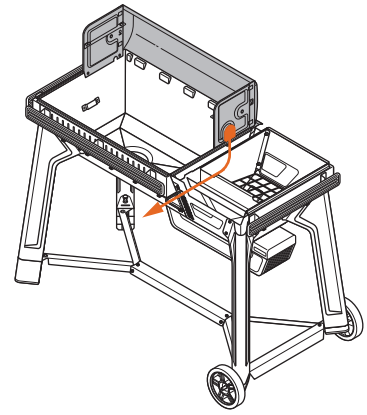

4A

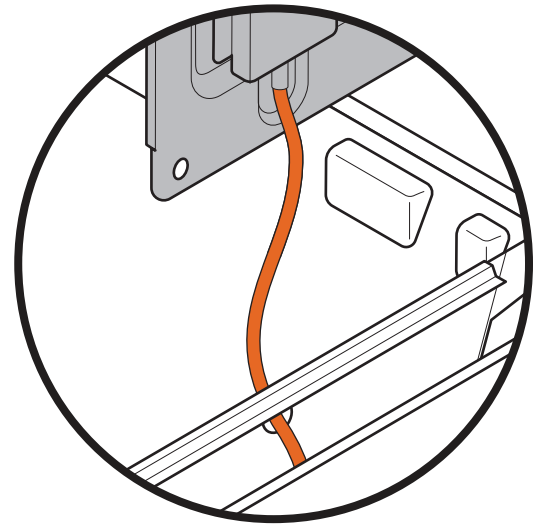
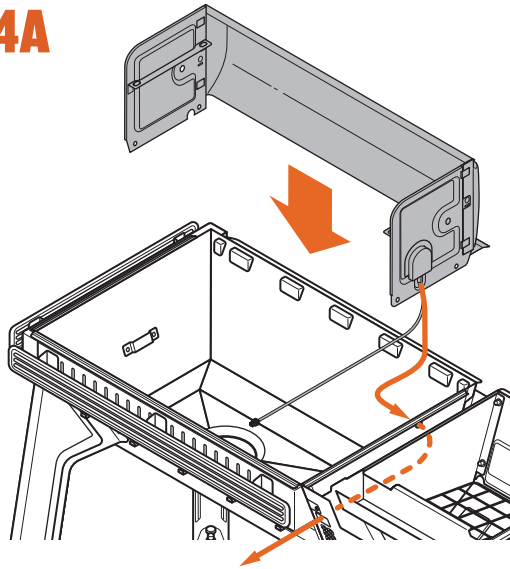

4B

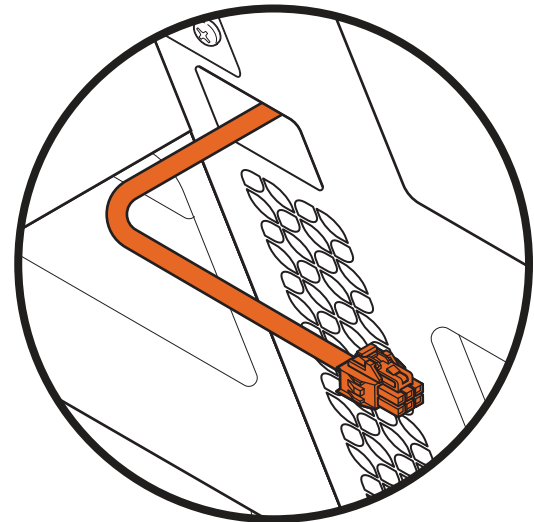
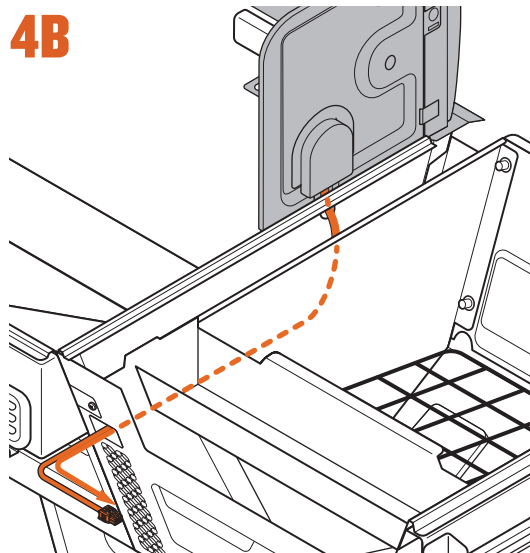



5 ATTACH BACKSPLASH

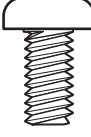
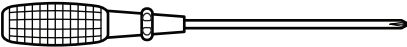

B x4

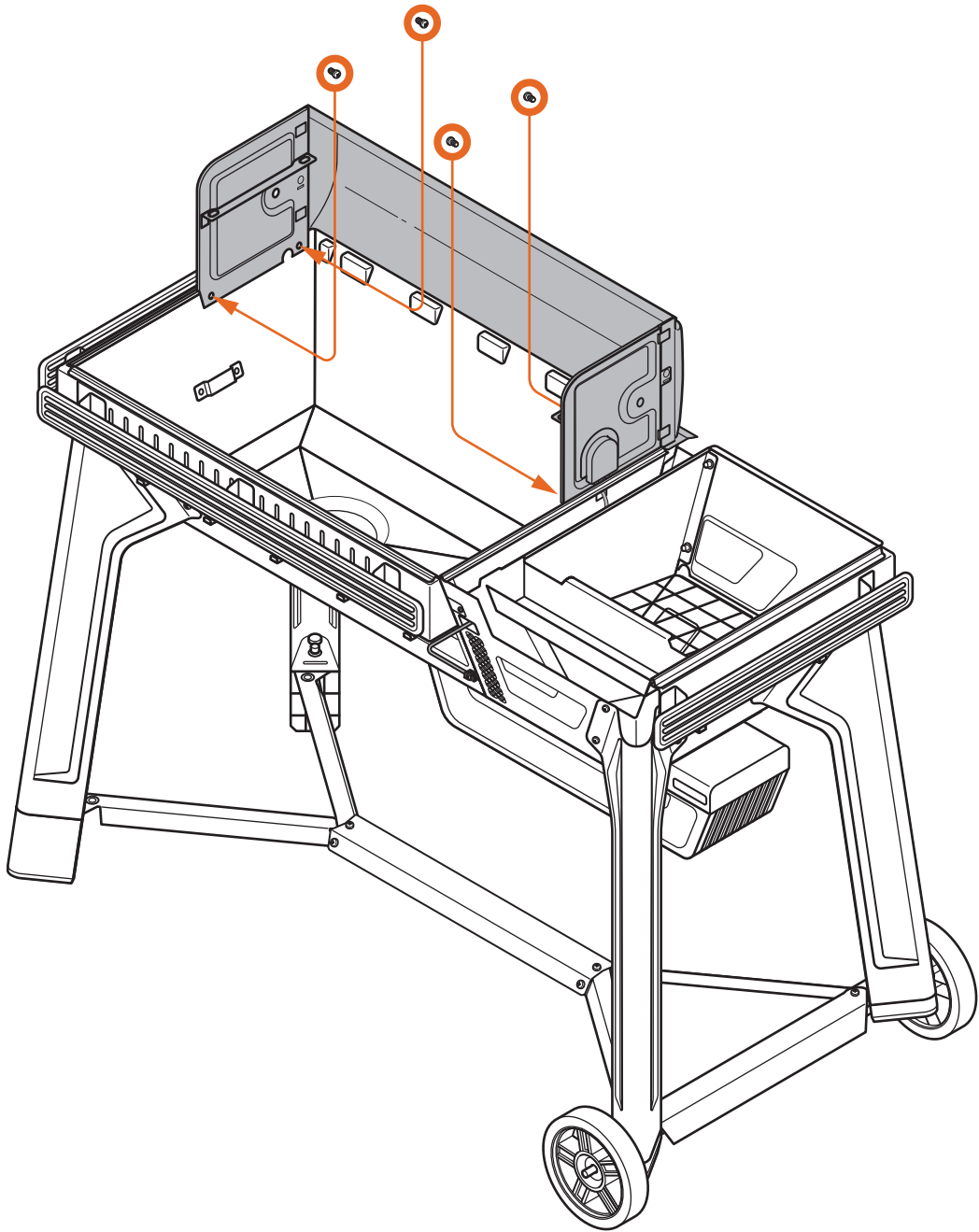
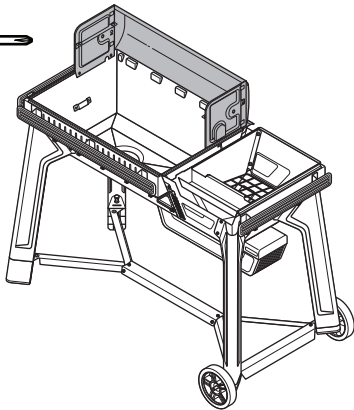



6 INSTALL REAR HOOKS

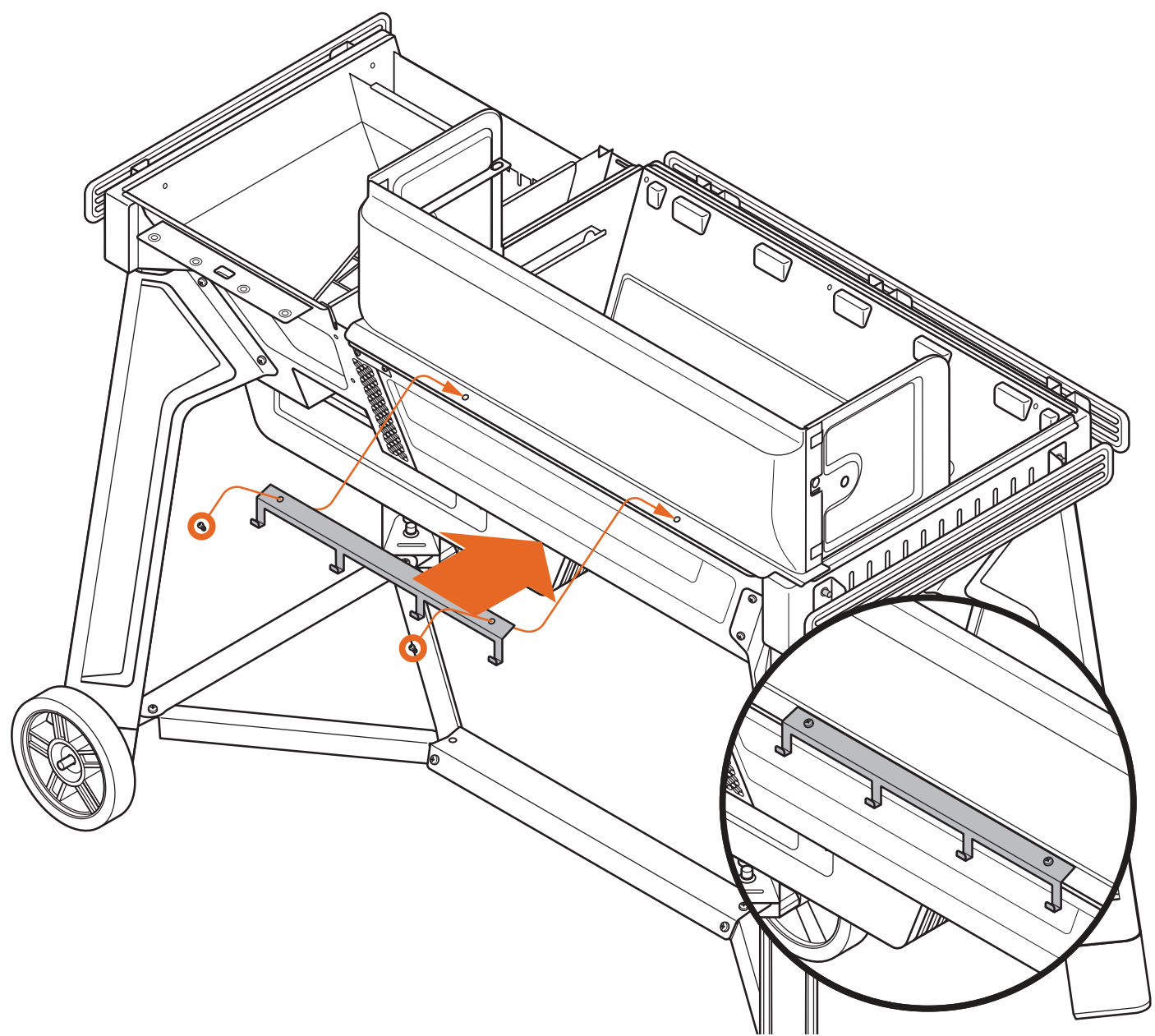
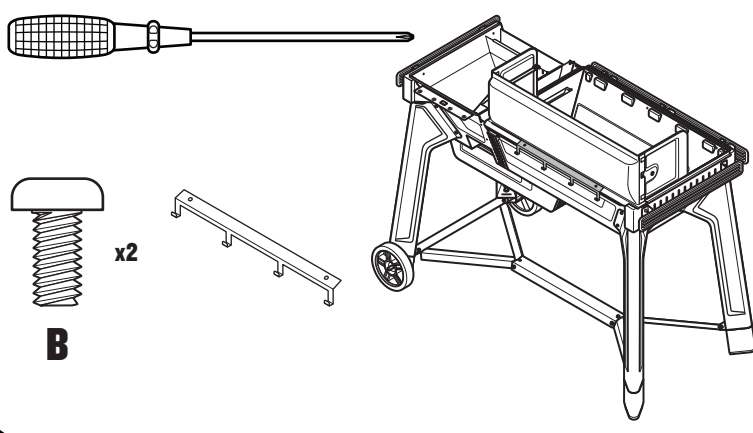



7 CONNECT CONTROLLER

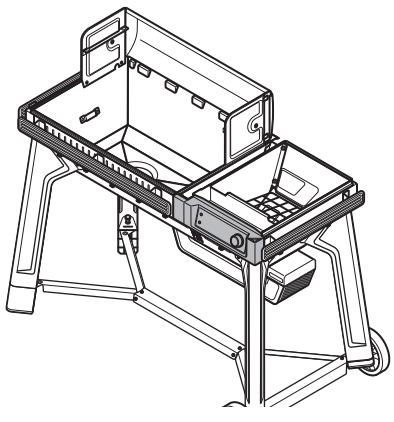
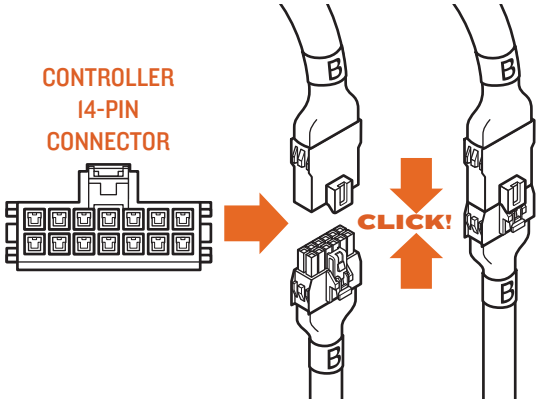

 **PRO TIP:** For easier connecting, lay the controller on its back on the edge of the hopper.

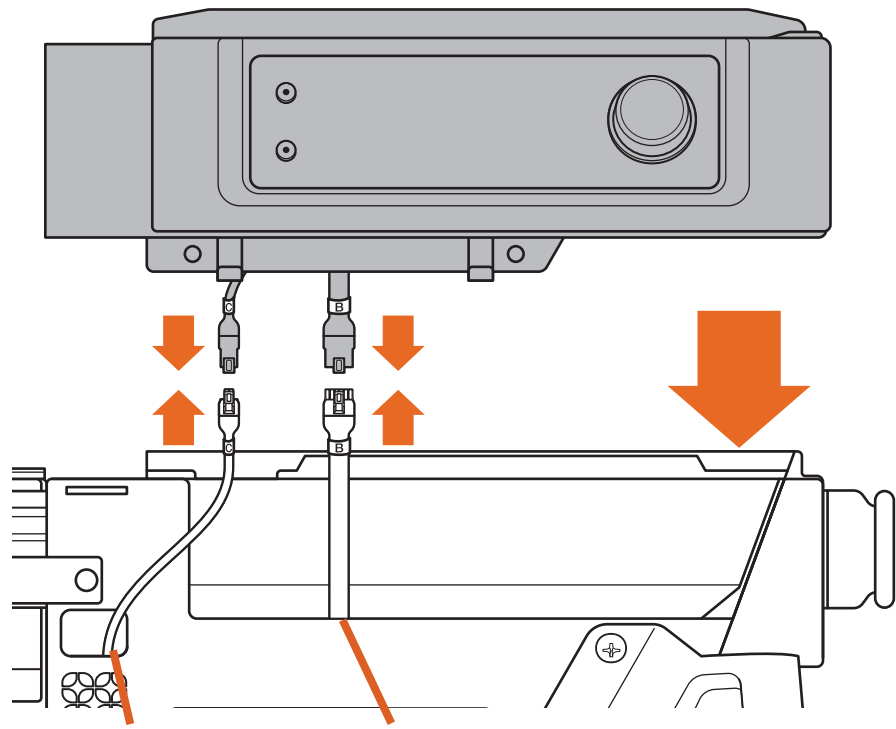
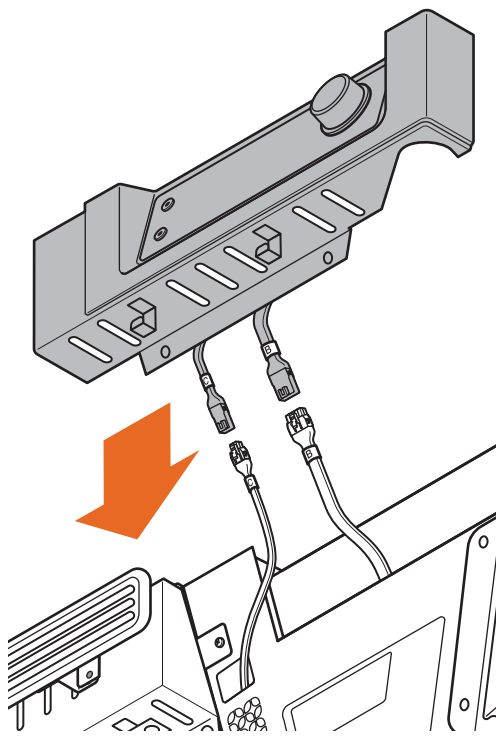

 **PRO TIP:** After connecting, tuck wires back into grill to prevent pinching them.

TEMPERATURE SENSOR
4-PIN CONNECTOR



CONTROLLER
14-PIN CONNECTOR

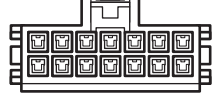

 **PRO TIP:** To more easily connect connector B, cut the zip tie holding it to the grill.



 **PRO TIP:** Install controller over flange in hopper.

8A ATTACH CONTROLLER

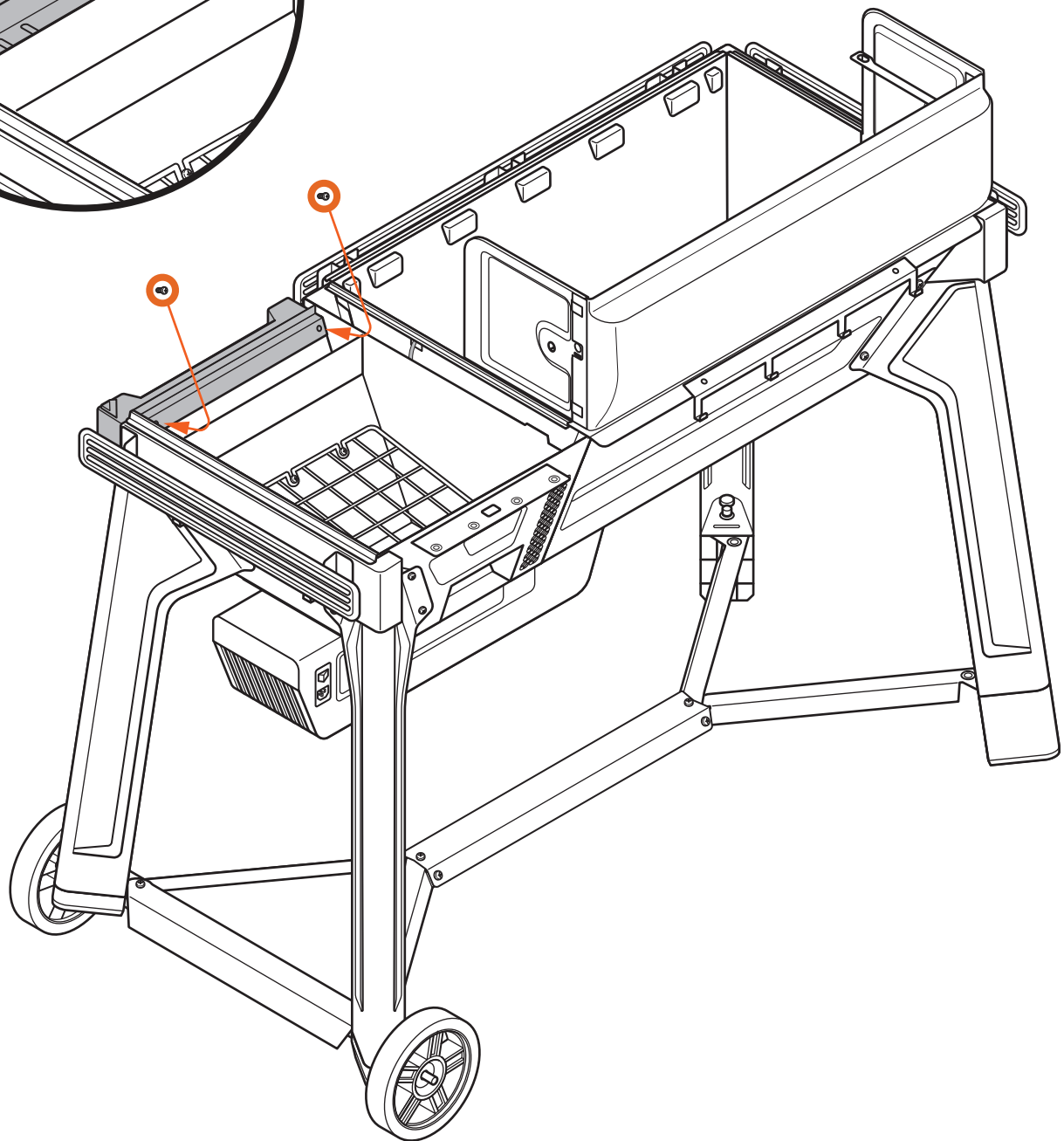
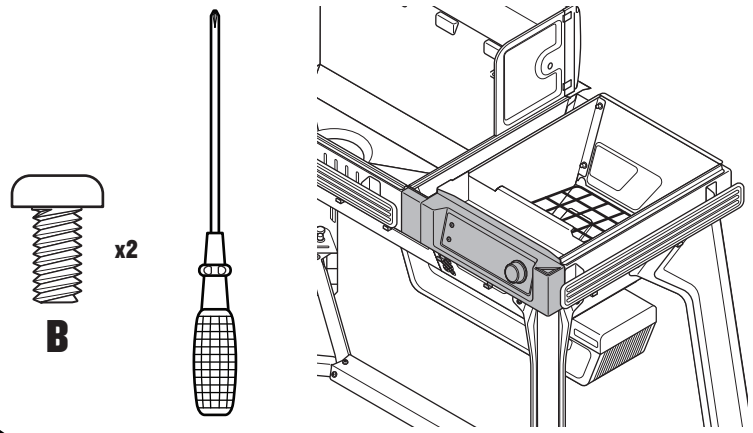
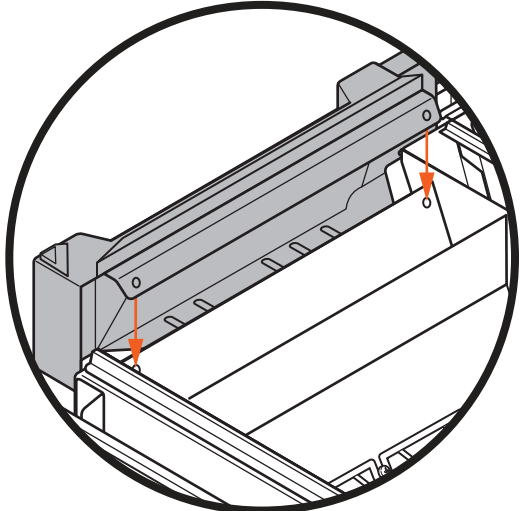



8B ATTACH CONTROLLER

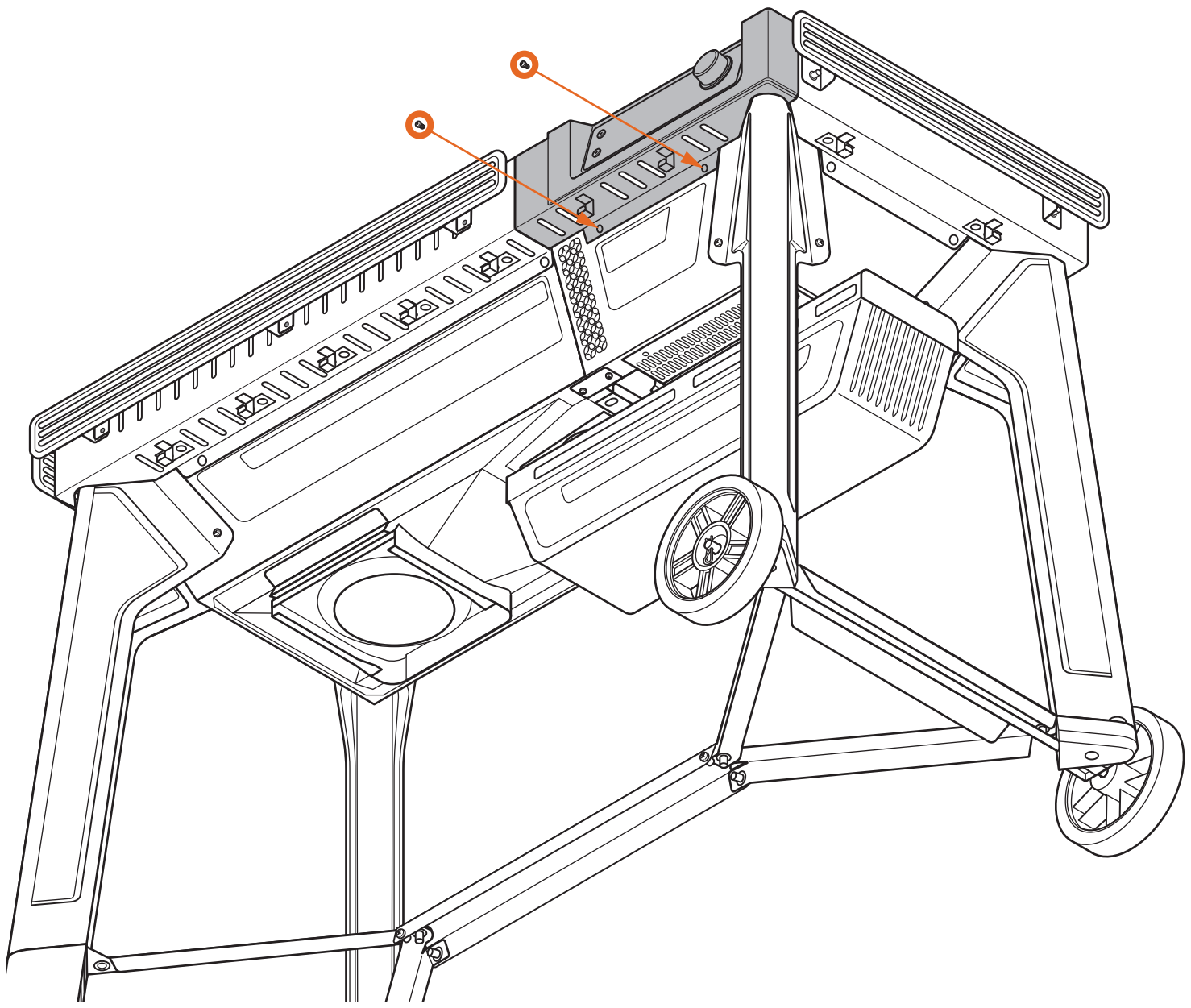
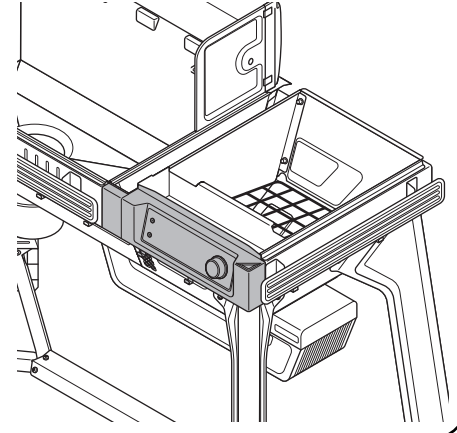
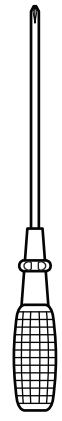
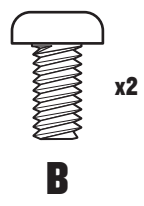

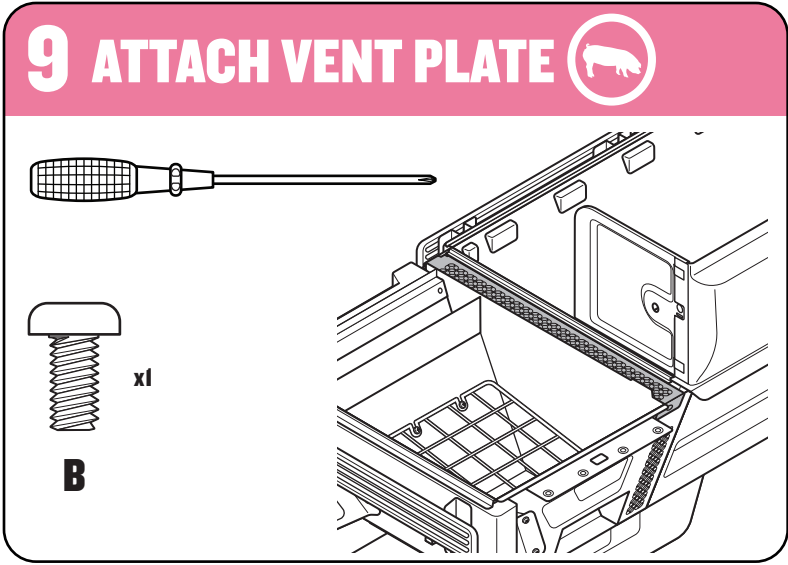

9A

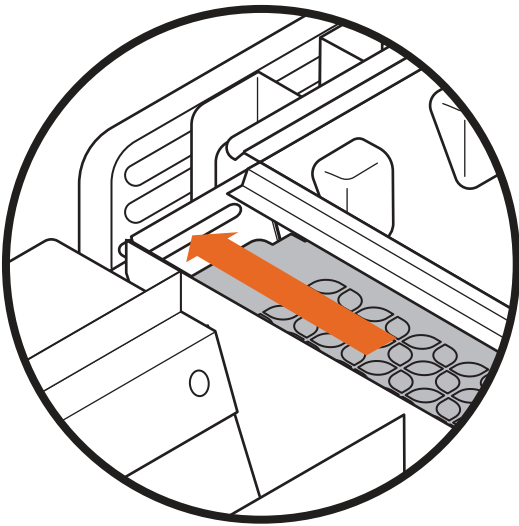

9B

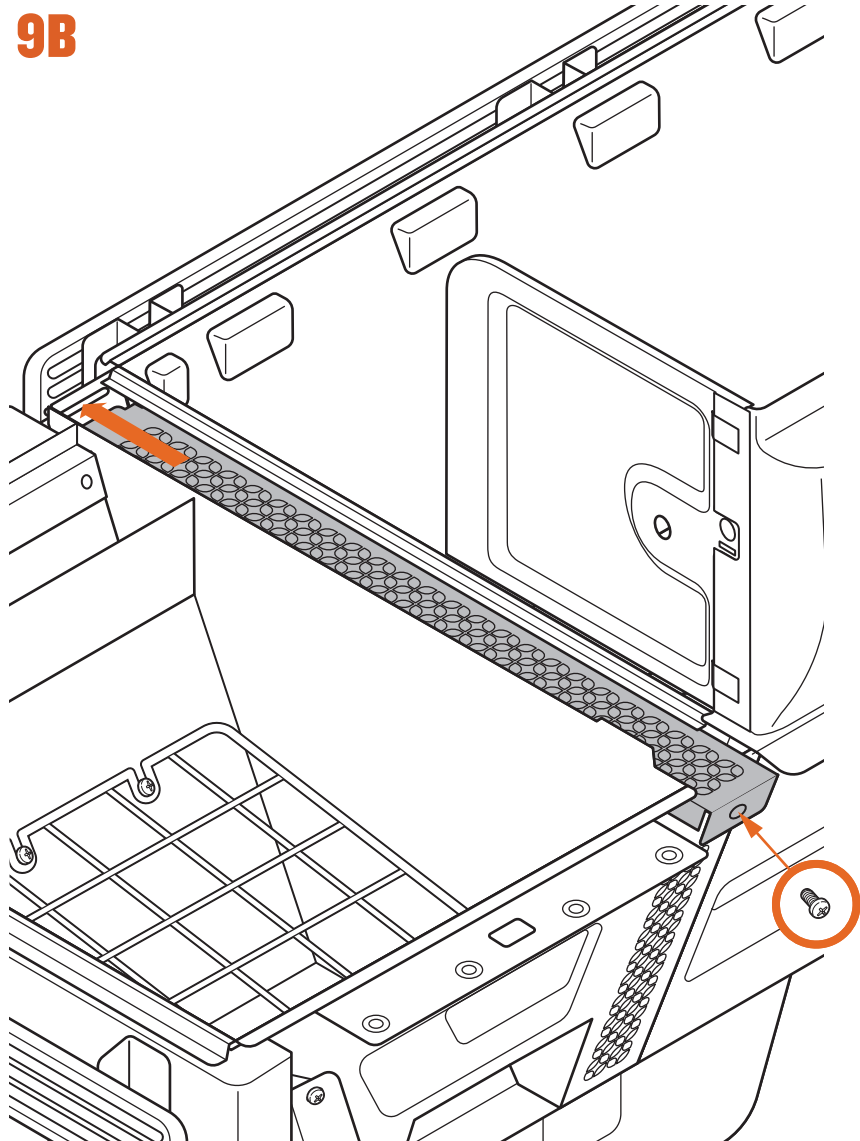

NICE WORK!
CHAPTER 3 COMPLETE!

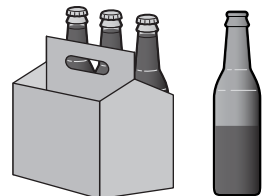

CHAPTER 4

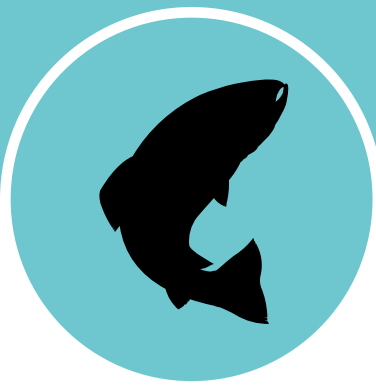
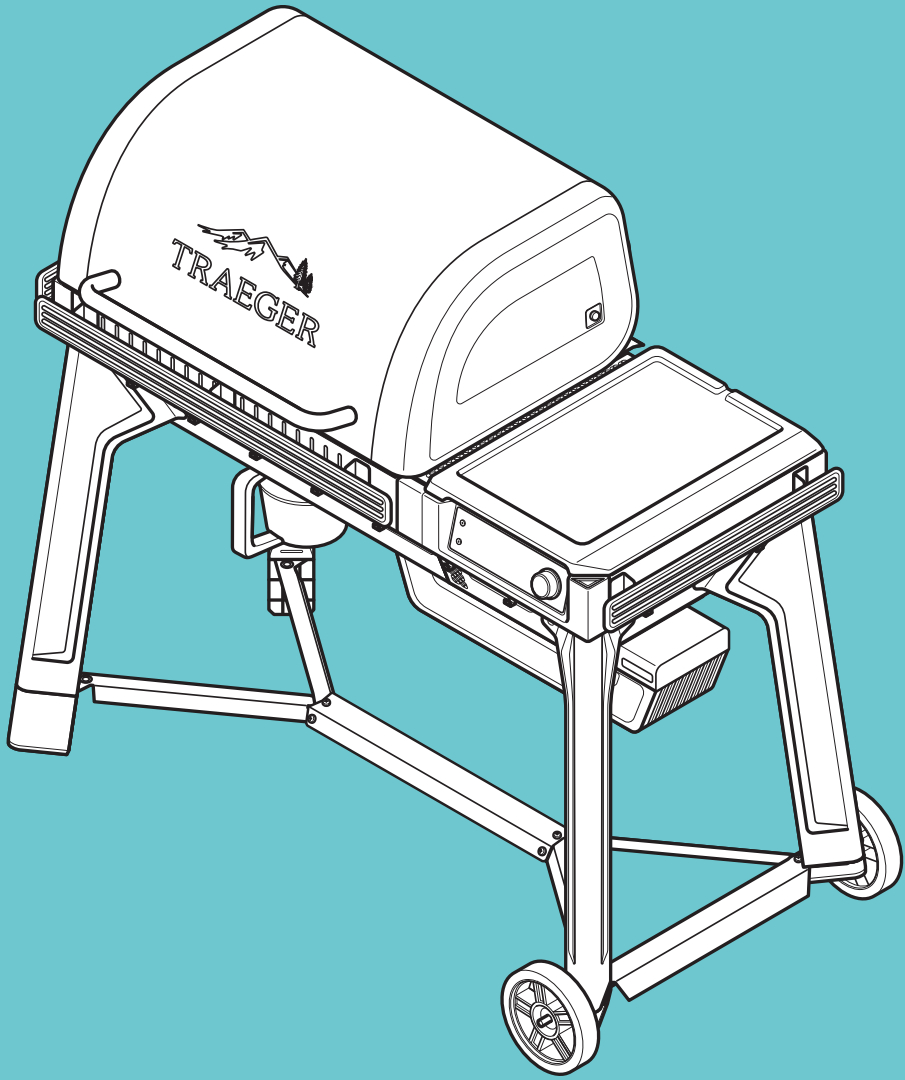

LID & GRILL INTERNALS

CHAPTER 4

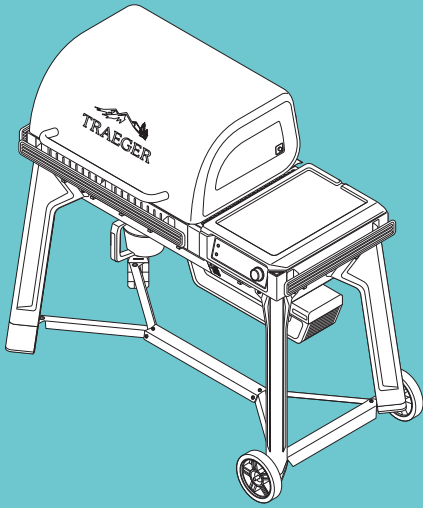

1 ATTACH HOPPER LID

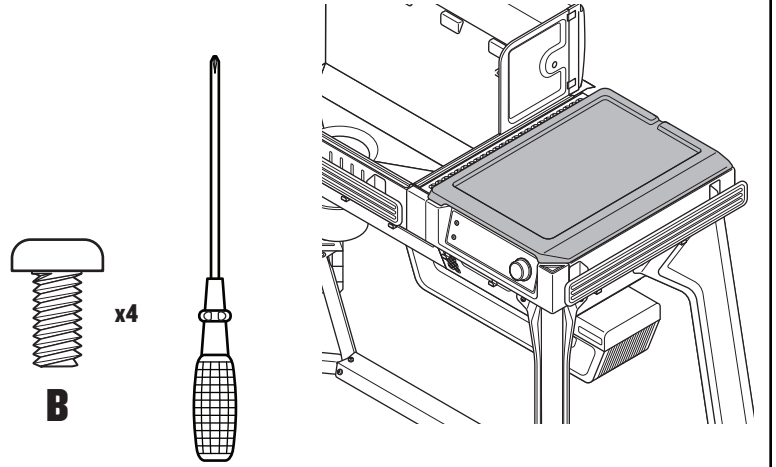

PRO TIP: Hand-tighten all screws first, then finish tightening with screwdriver.

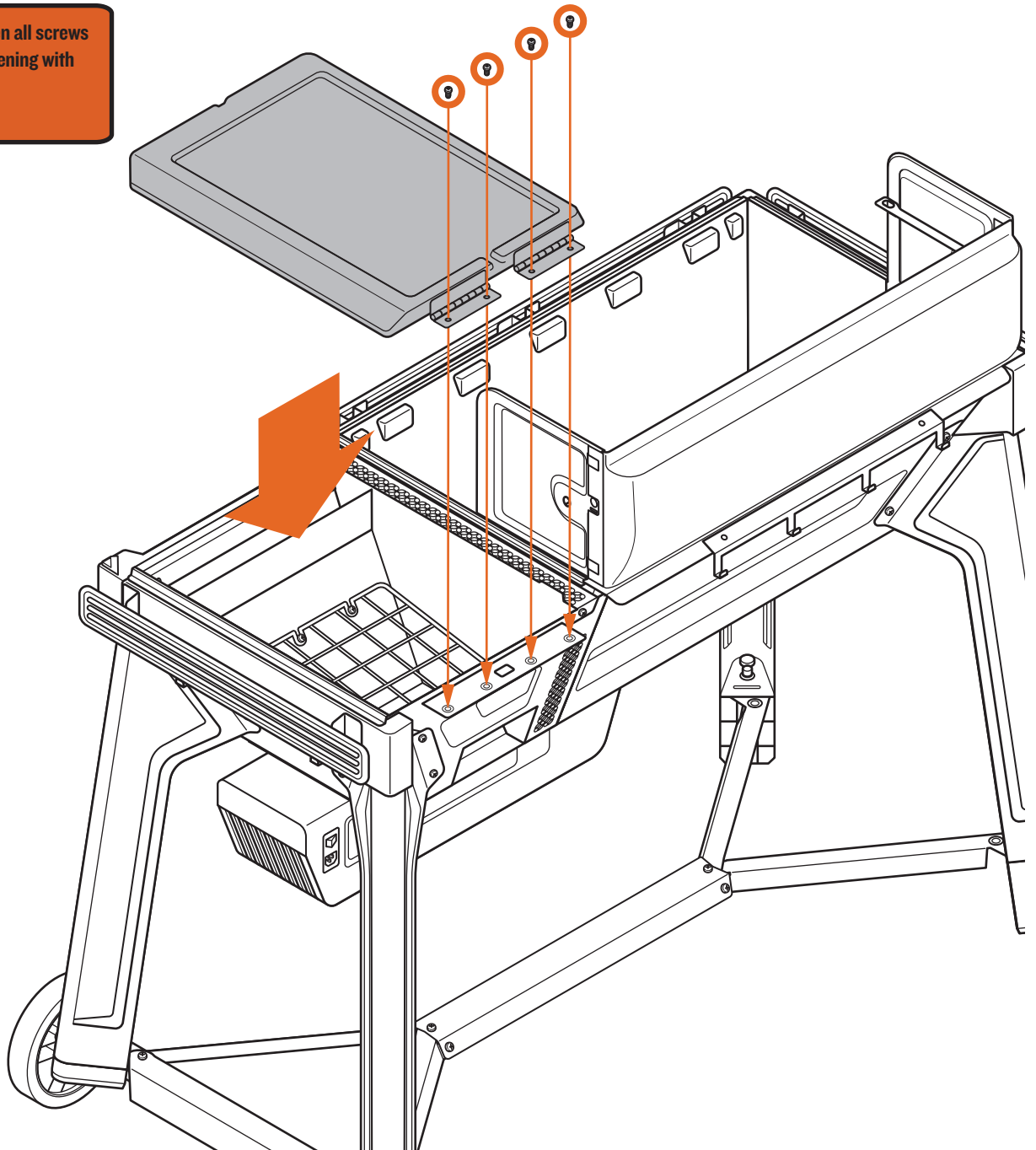



2A INSTALL CHUTE, SHIELD, AND BAFFLE

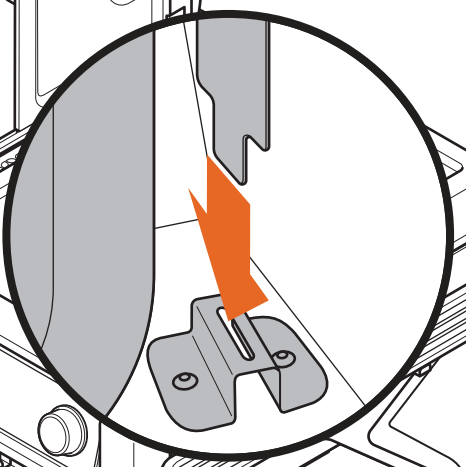
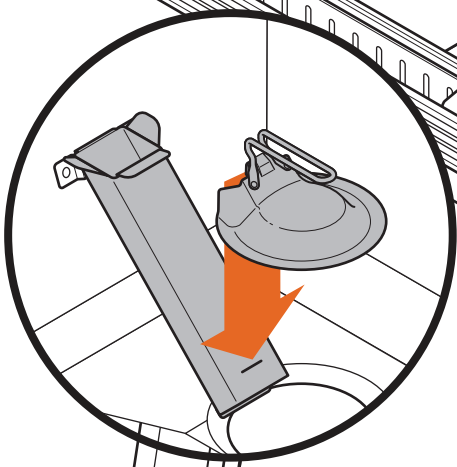
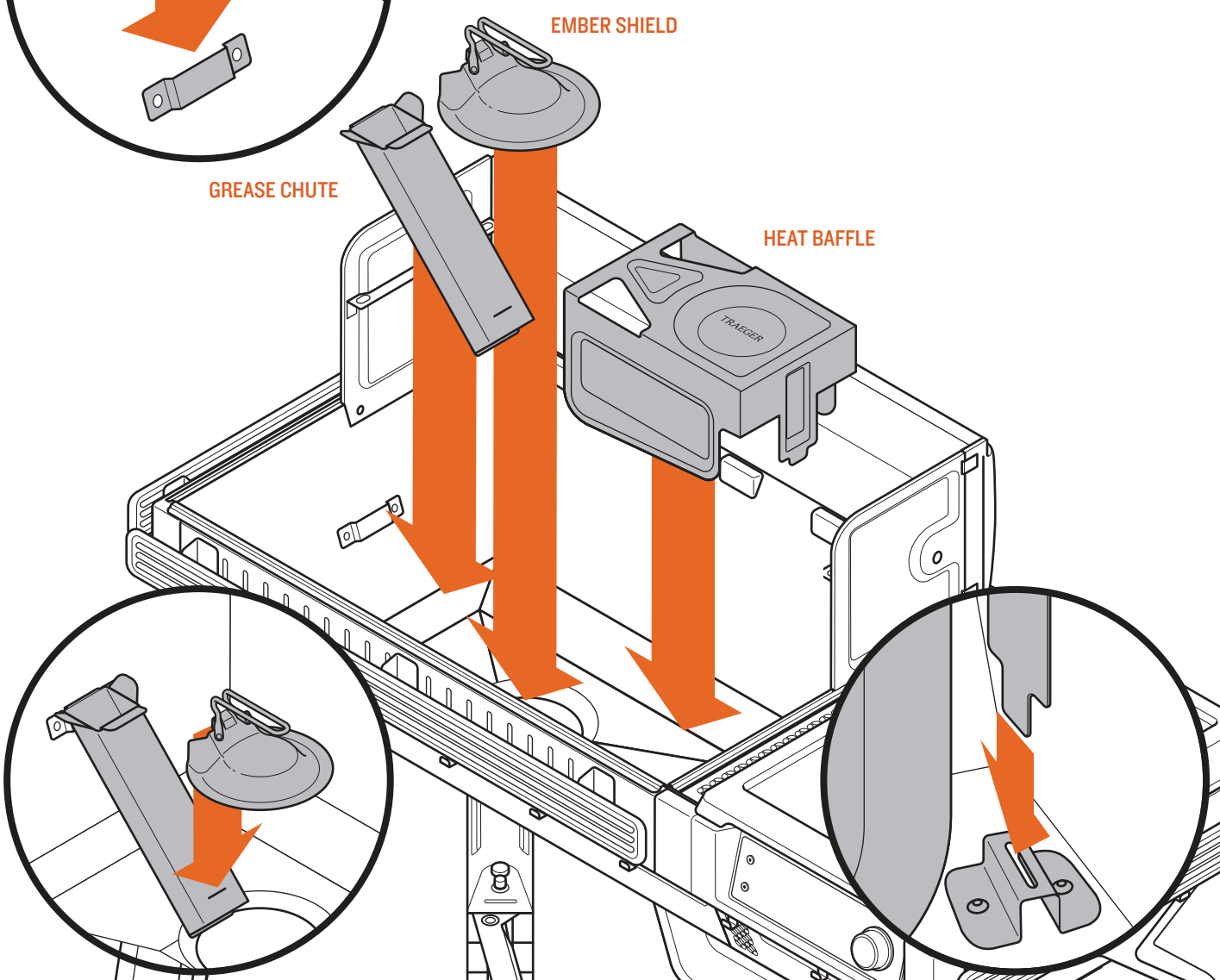
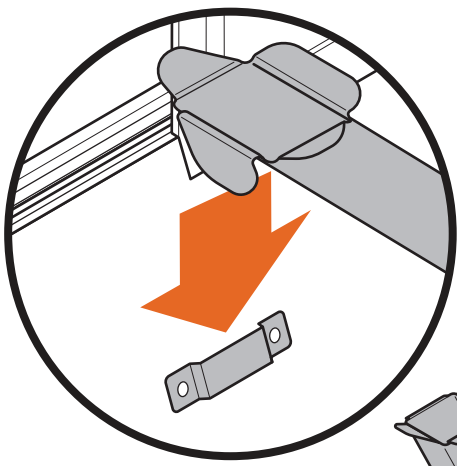
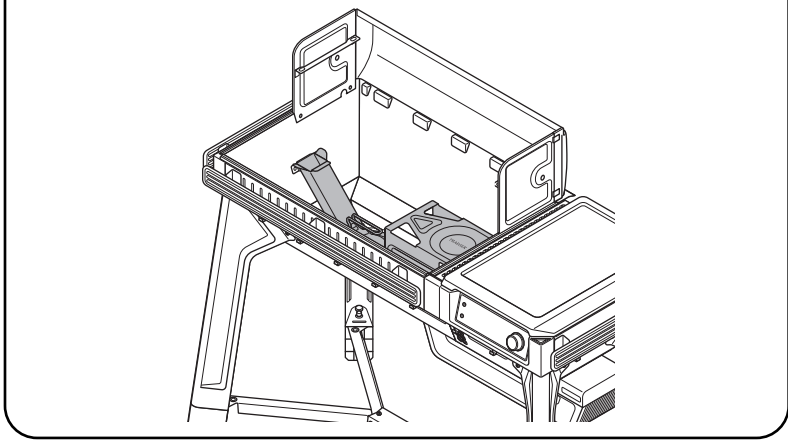
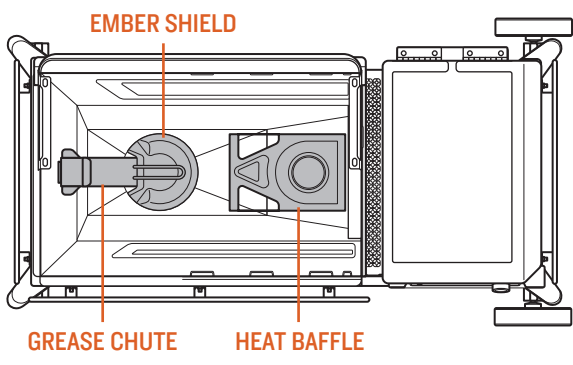



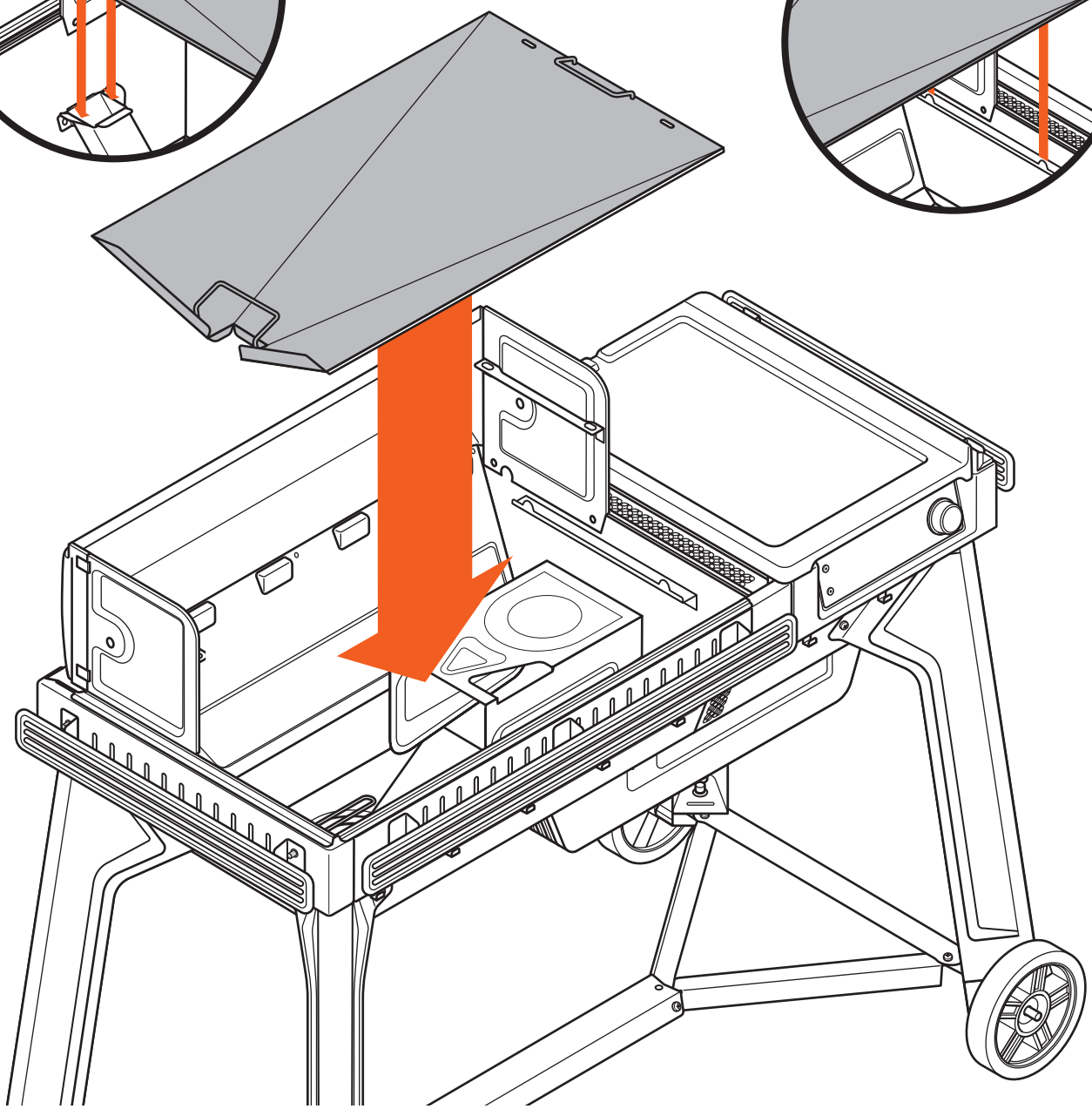
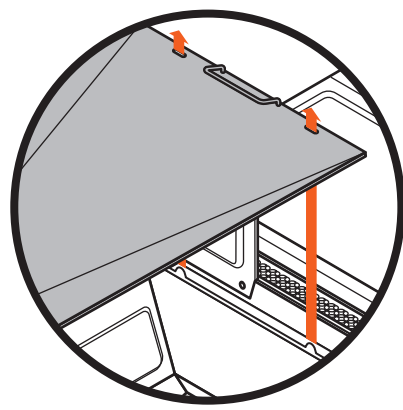
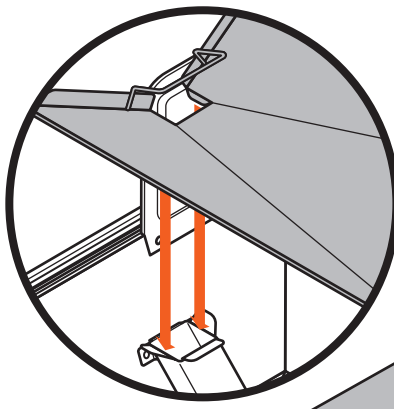
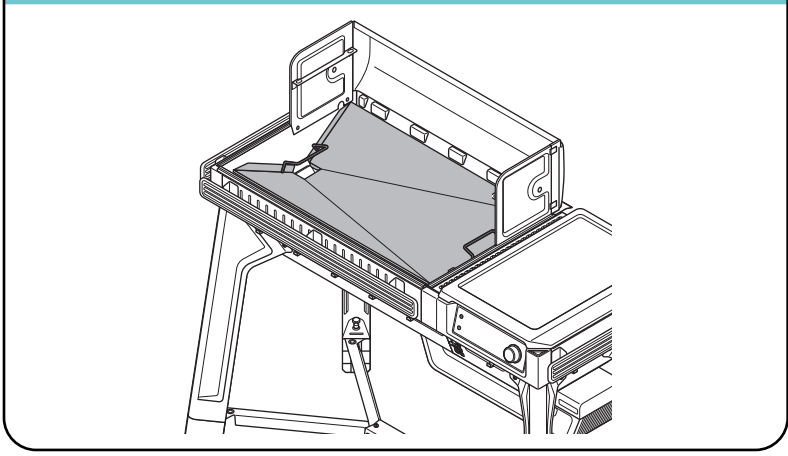

2B INSTALL DRIP TRAY





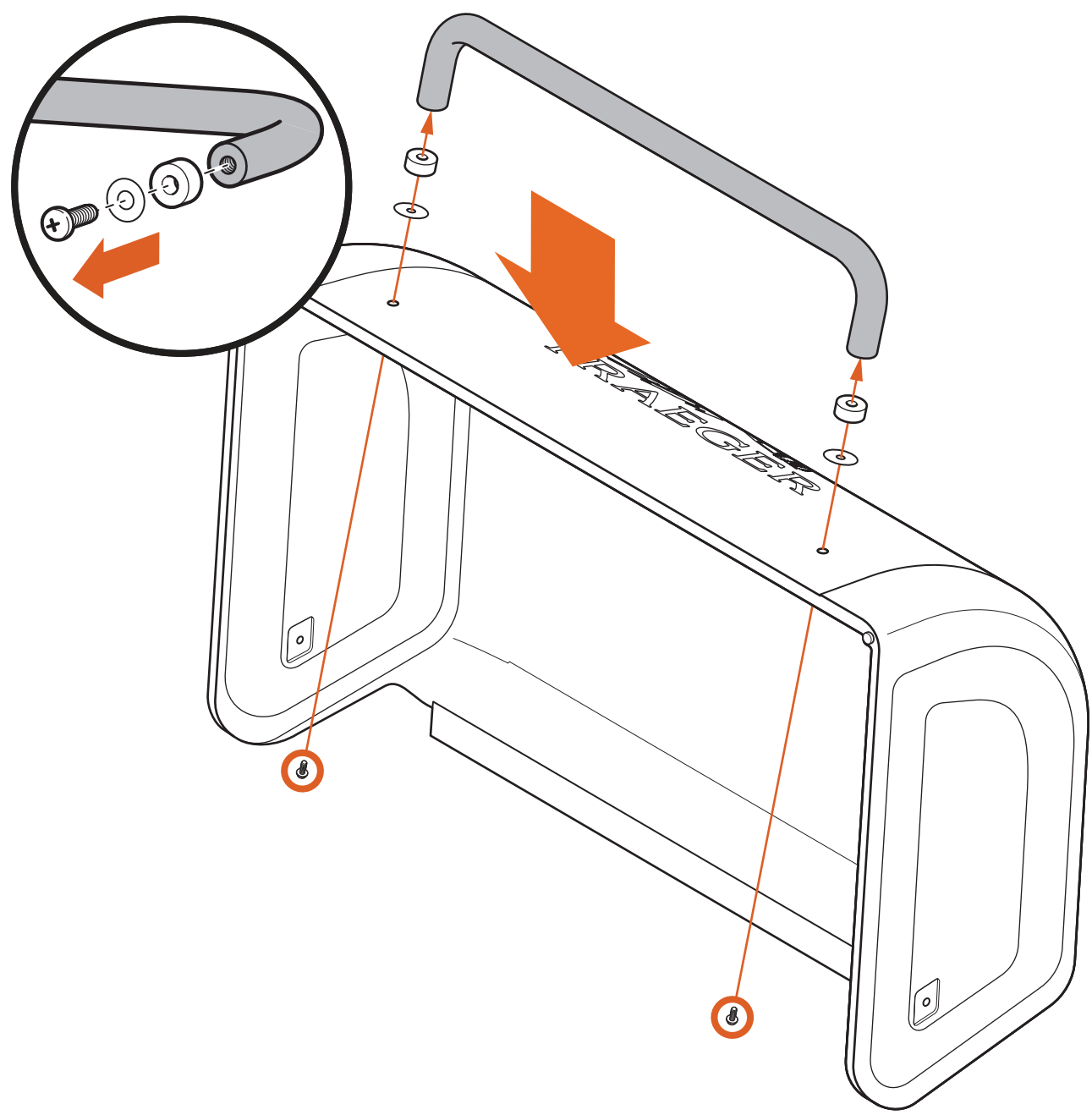
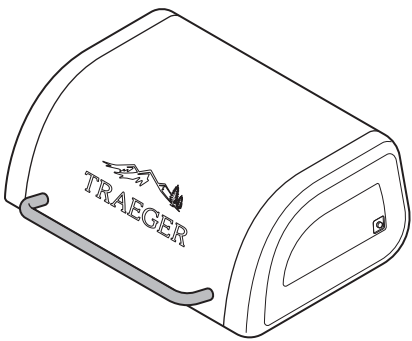
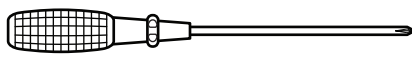

3A ATTACH LID HANDLE





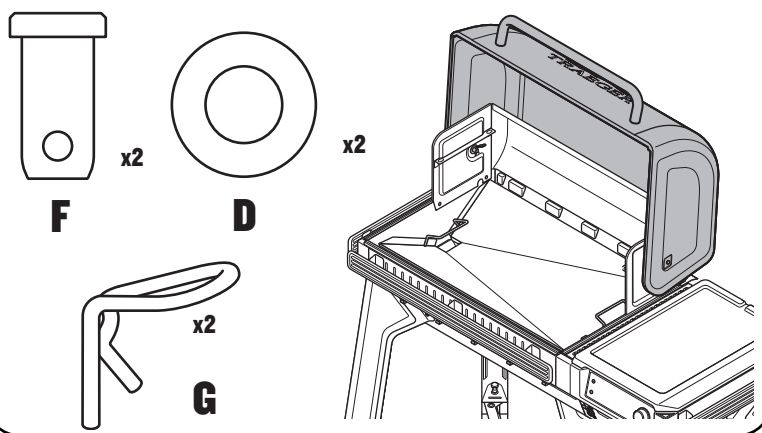

PRO TIP: Use two people to attach the lid.

3B ATTACH LID



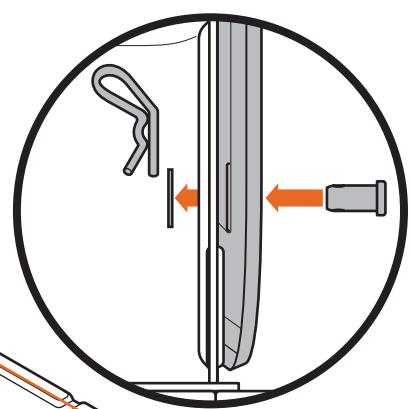
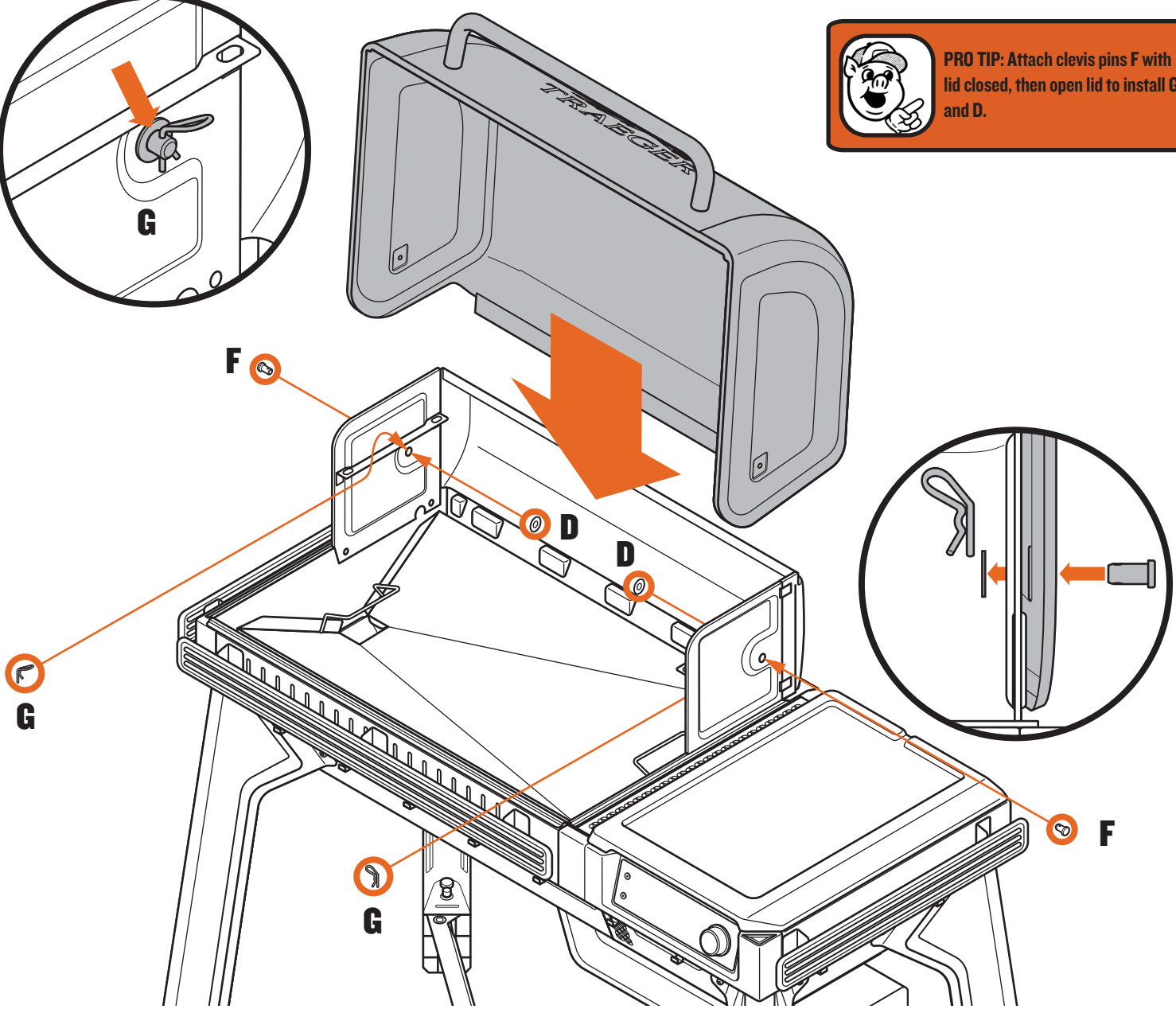

PRO TIP: Attach clevis pins F with lid closed, then open lid to install G and D.



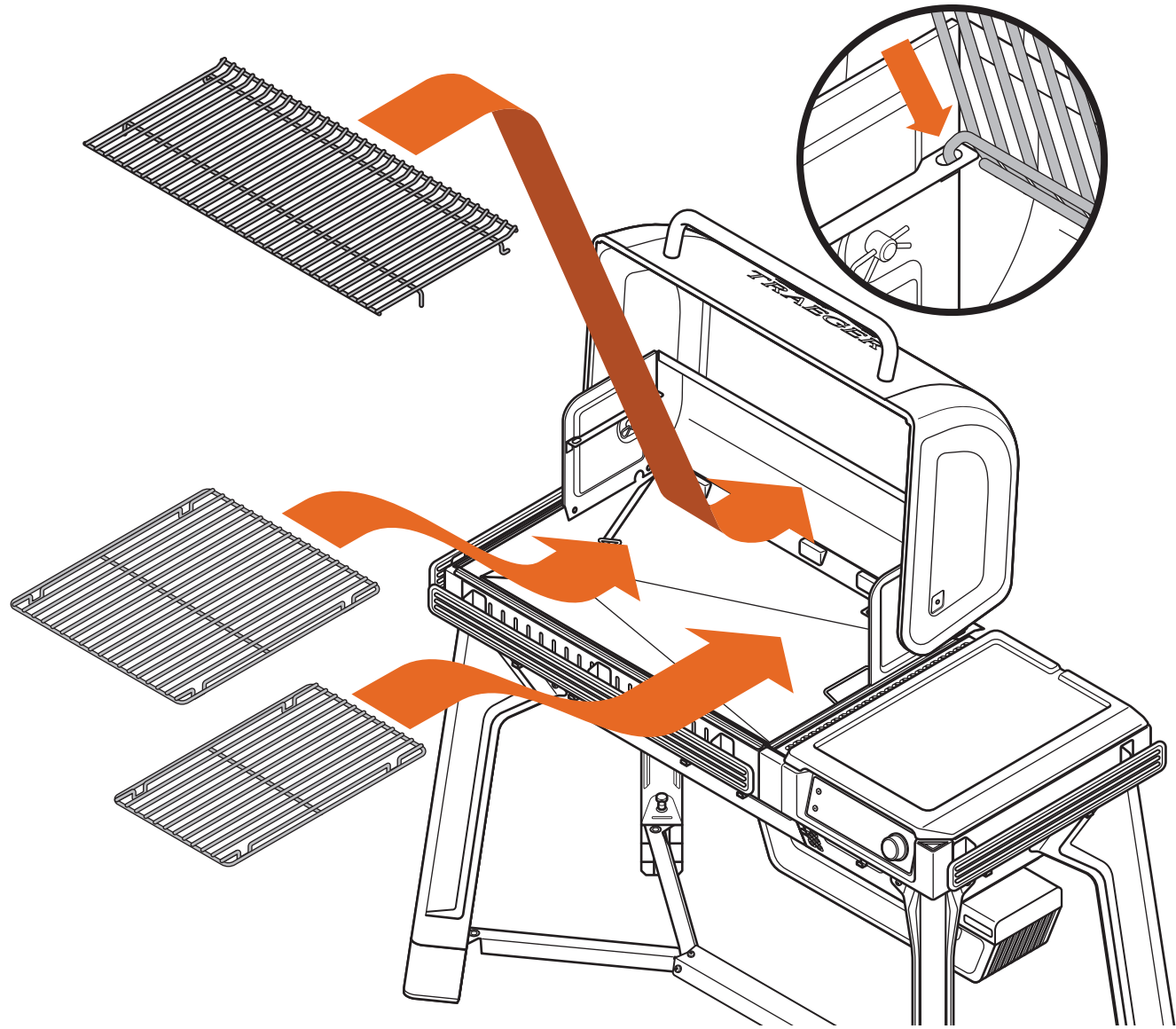
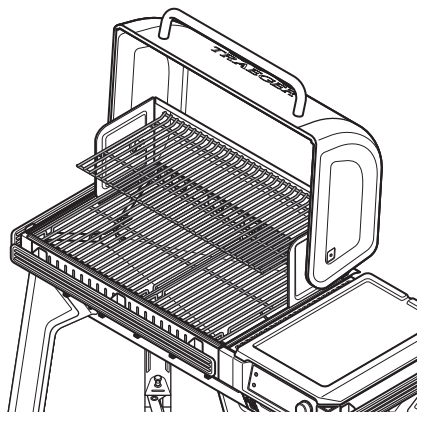

4 INSTALL GRATES





5 INSTALL GREASE & ASH KEG

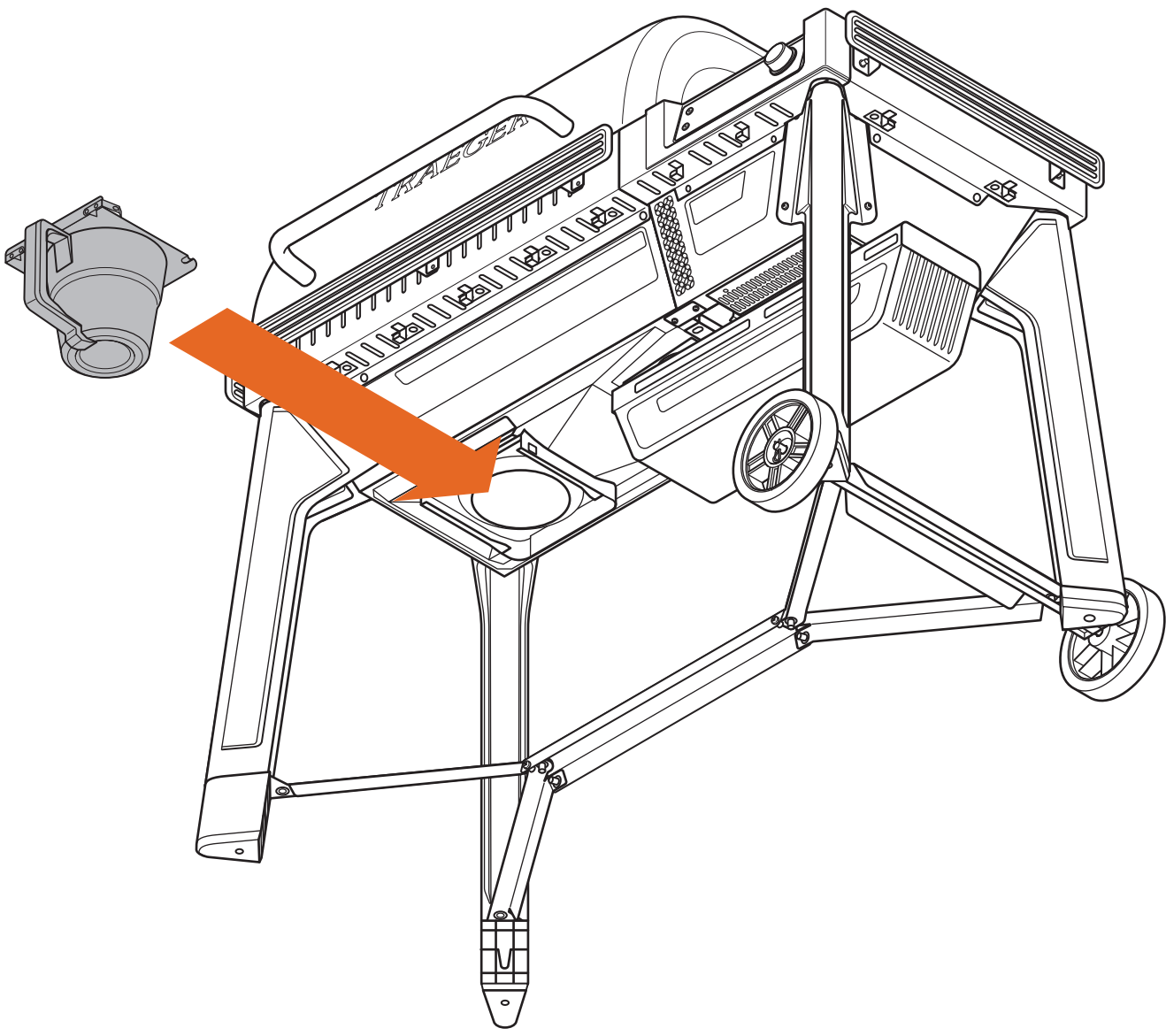
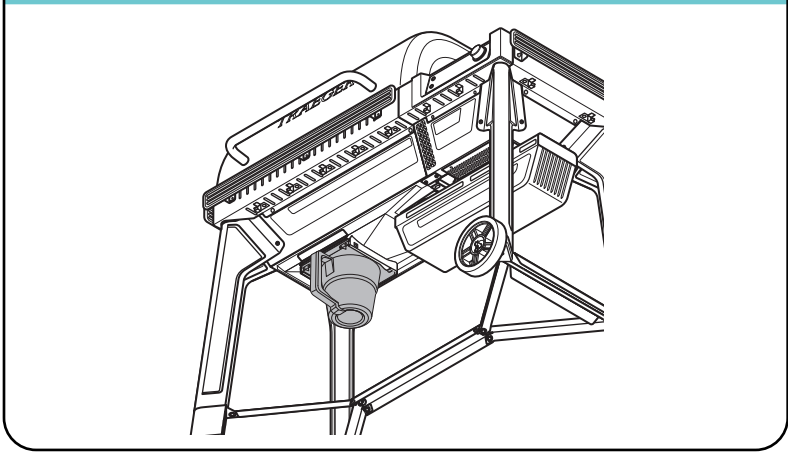



6 PLUG IN POWER CORD

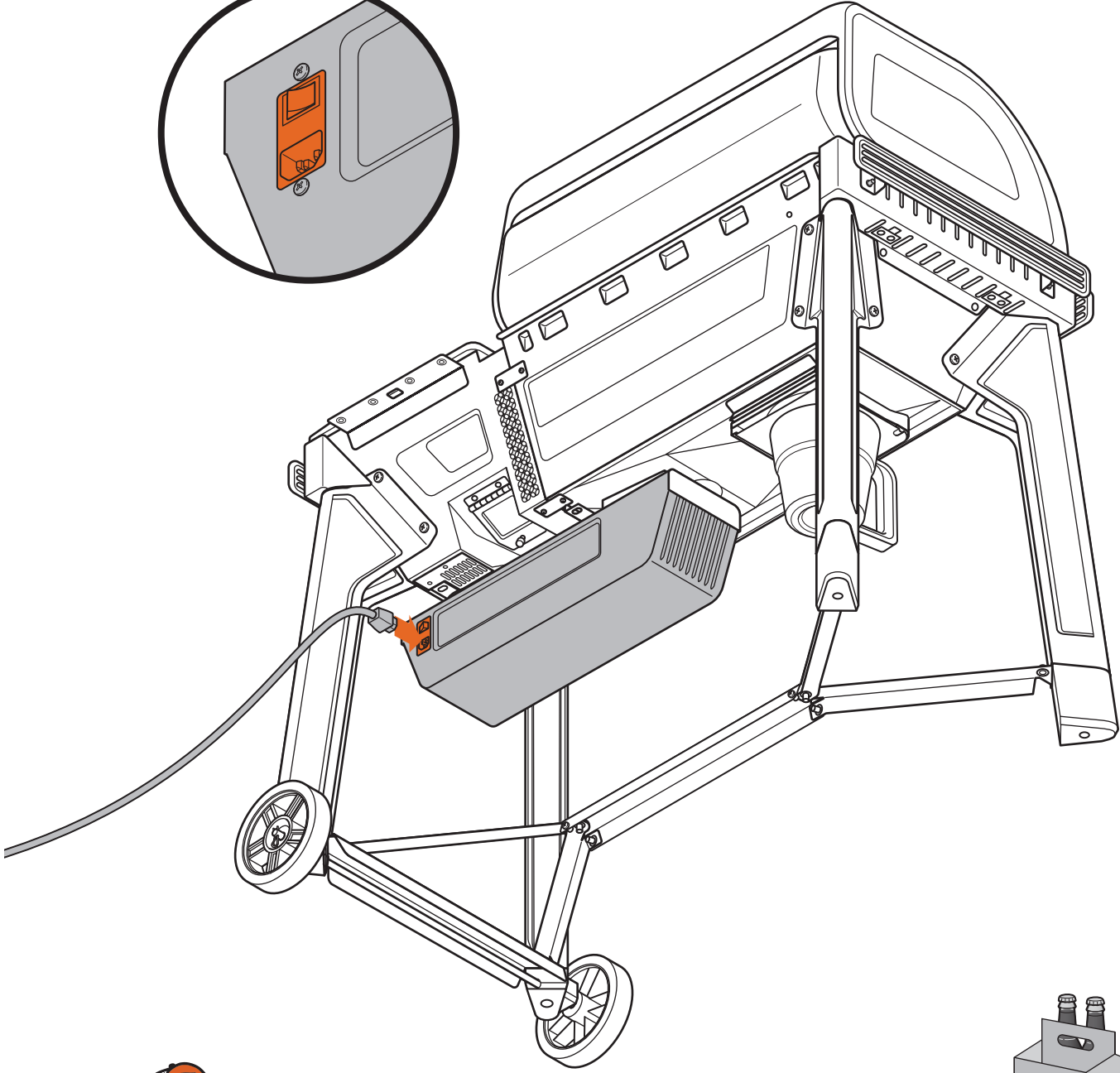
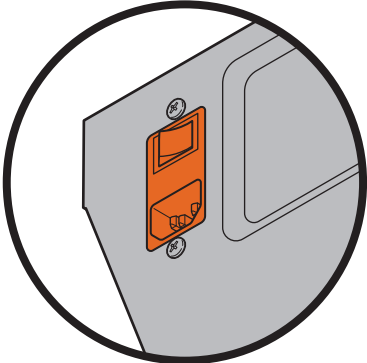
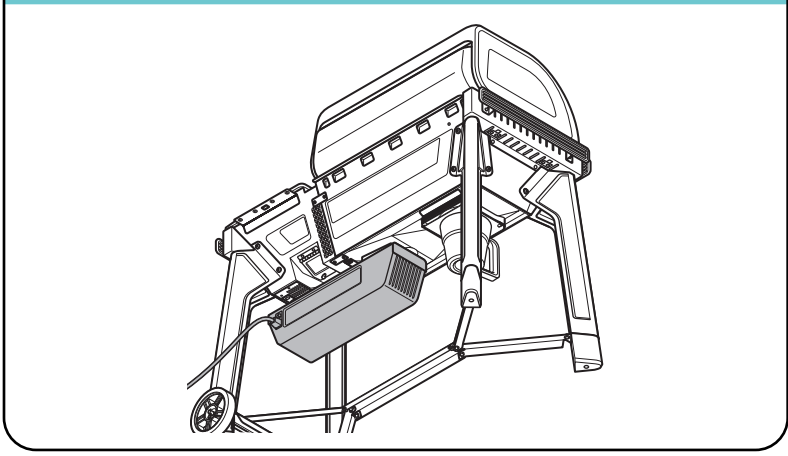

NICE WORK!
CHAPTER 4 COMPLETE!

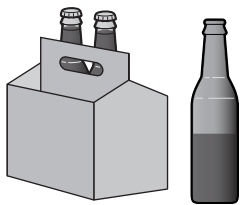

STORING PARTS AND ACCESSORIES

Wired Probe and Power Cord

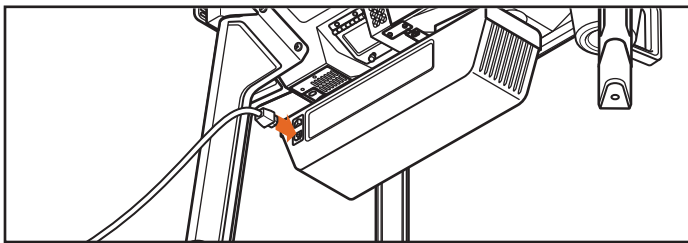
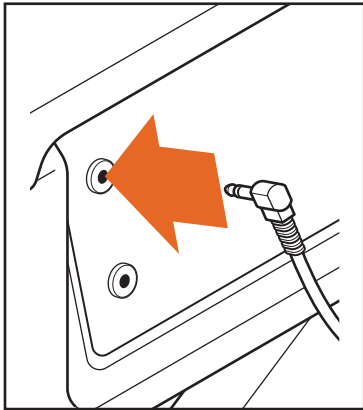

TO STORE:

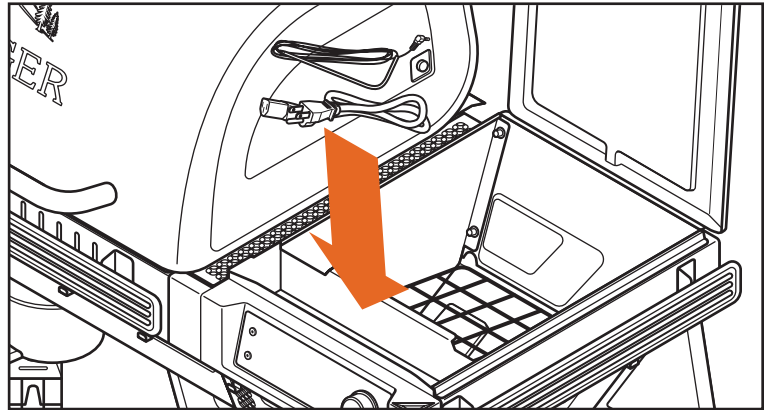

Grill Grates, Drip Tray, Grease Chute, and Ember Shield

TO STORE DURING CLEANING:

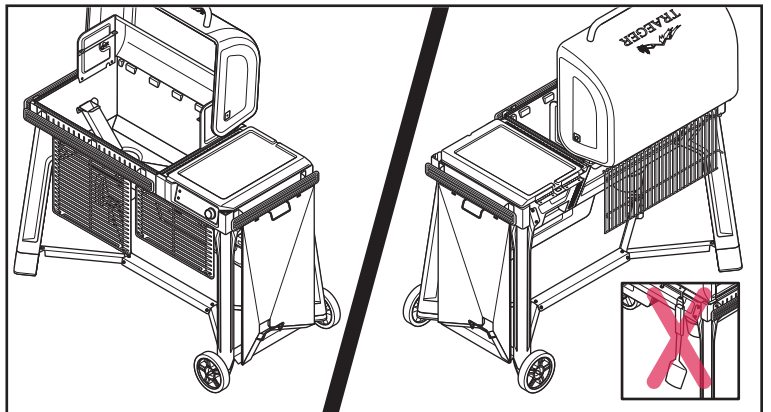
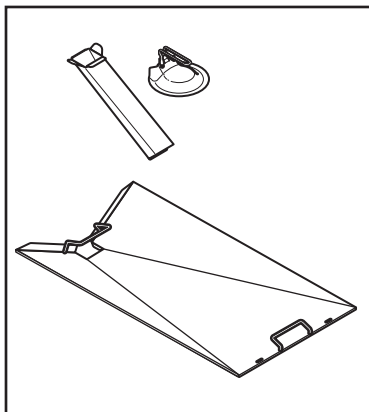
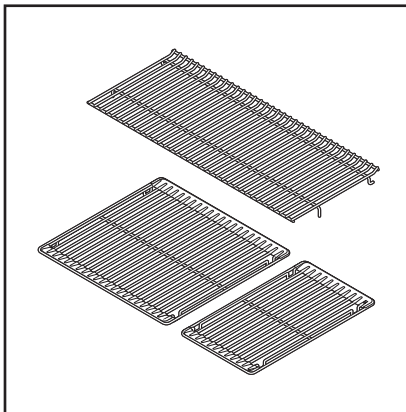

PRO TIP: Do not hang or store cooking utensils or power cord on grate hooks. Doing so could damage the utensils or power cord.

CONNECTING YOUR GRILL

Our dedication to delivering world-class products and experiences means we are constantly working to improve grill performance and features. We highly recommend connecting your Traeger Woodridge Grill to WiFIRE by following the instructions below. When your grill is connected and on, updates will automatically download, ensuring your grill is always operating at peak performance.

IMPORTANT:

- Make sure your smart device is running on the latest operating system and that Bluetooth is turned ON.
- If using an Android device, turn on location services.
- To connect your grill to your home Wi-Fi, your grill must be powered on. Make sure the main power switch is pressed to ON (I) and lit up.
- Your home Wi-Fi router signal must be 2.4 GHz (a dual band router should also work). The 2.4 GHz band is currently industry standard for connected appliances. It has better range and penetrates walls/ceilings/obstacles better than 5 GHz, which your grill cannot recognize.

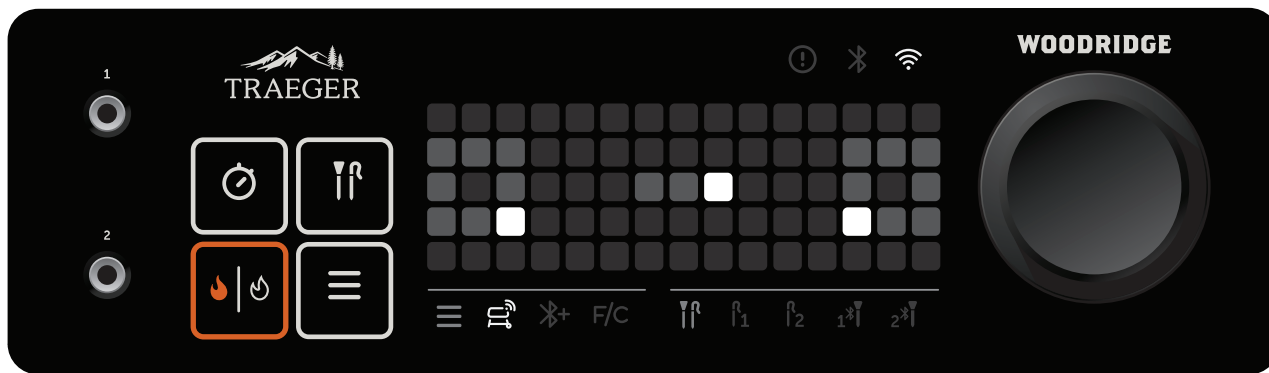

PRO TIP: Check under your hopper lid for a handy quick reference guide to your Woodridge controller!



Go to the Apple App Store or Android Google Play Store to download the latest version of the Traeger App.

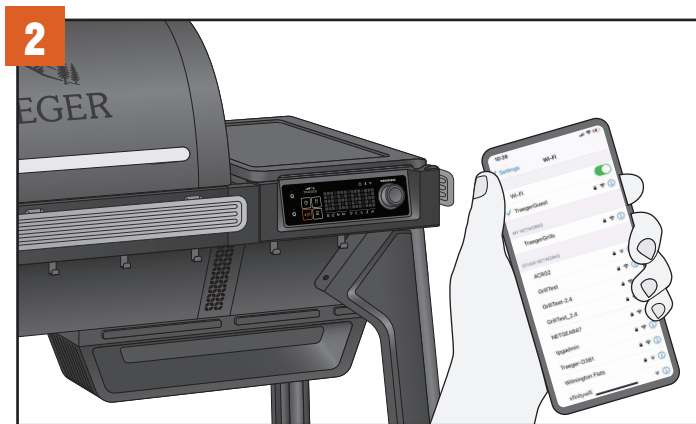

Ensure your smart device is connected to the Wi-Fi network to which you want your grill connected. The router signal must be 2.4 GHz, as the grill is not compatible with 5 GHz.

CONNECTING YOUR GRILL CONTINUED

3

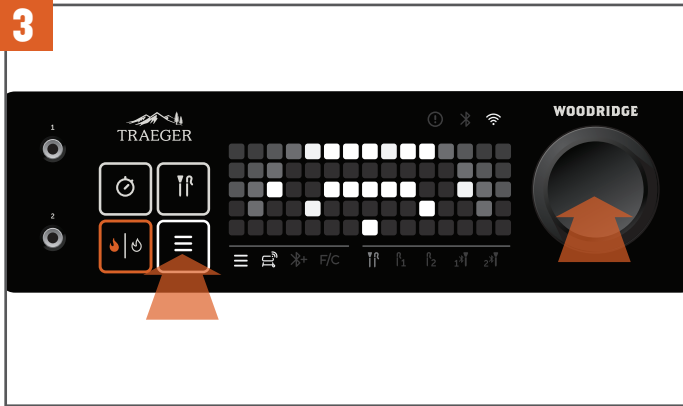

After powering on your grill, tap the menu button. You will see the Wi-Fi grill icon light up in the menu bar below the dot matrix, and an animation of a Wi-Fi signal with a question mark will be displayed. Press the selection dial to select this option and begin the connection process.

NOTE: You can navigate menu options by turning the selection dial after tapping the menu button. As you turn the dial, the menu bar icons below the dot matrix display will light up to indicate your selection.

4

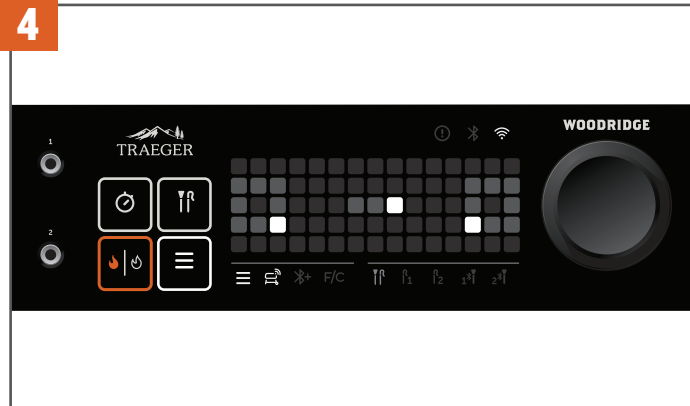

After selecting Wi-Fi, the pairing animation above will display on screen, indicating that your grill is broadcasting its Bluetooth signal and is ready to pair. Open your smart device to the Traeger App and sign in to your account. On the home screen of the Traeger App, tap the grill icon in the lower center of the screen to start connecting.

Follow the instructions on the Traeger App to (1) pair your phone to your grill (via temporary Bluetooth connection), (2) connect your grill to your desired 2.4 GHz home Wi-Fi network, and (3) complete the grill setup process.

5

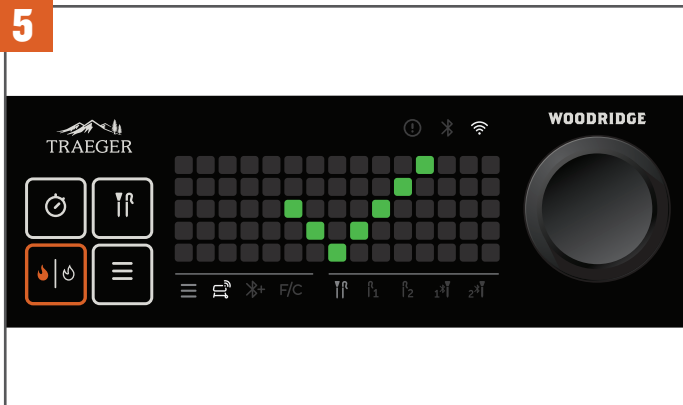

A green checkmark will display on your controller to indicate that you have successfully connected to Wi-Fi. The Wi-Fi icon in the top right above the matrix display will stay lit up when the grill is connected.

6

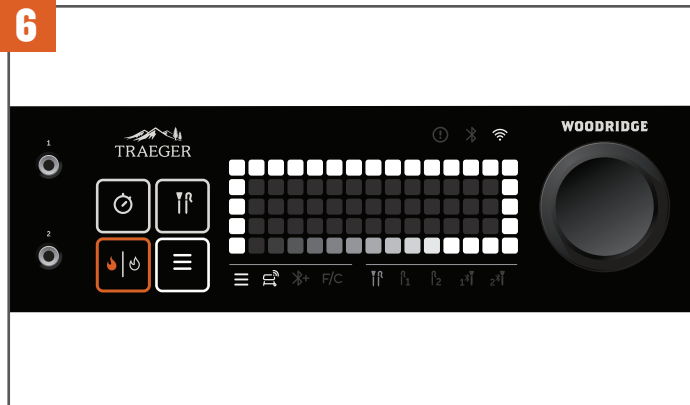

Once connected to Wi-Fi, you might see this animation on your screen. Don't turn off your grill until you see a green checkmark. This means that your grill is downloading and applying an update. Just like your smartphone, these updates keep your grill running smoothly, securely, and at peak performance. Once the update is done, you'll see a green checkmark and the grill will return to the idle mode – let's cook!

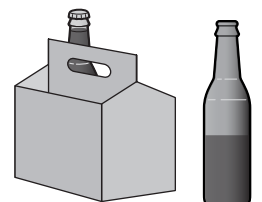

SEASONING YOUR GRILL

 **PRO TIP:** Seasoning must be completed before cooking food on your grill. For more information, scan here to access the Seasoning Guide.



Before you can cook on your grill, the grill must be seasoned. This is a hands-off process in which the empty grill gets heated to a very high temperature. This seasoning cycle ensures the grill is cleaned of any factory residue, primed, and ready for optimal performance.

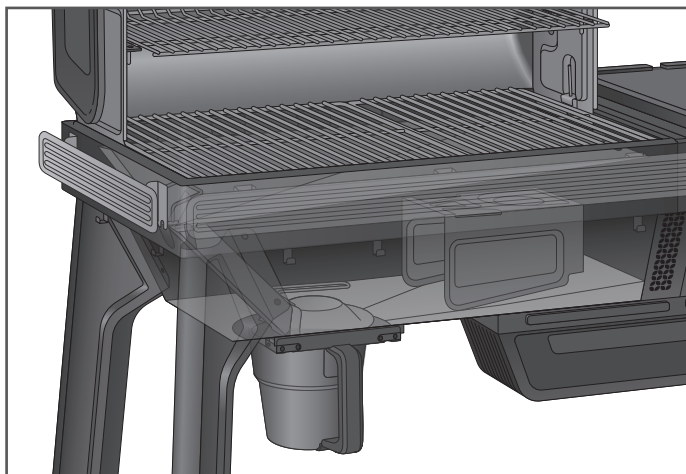

IMPORTANT:

- Make sure all components are properly installed in the grill and that all packaging/shipping materials are removed prior to seasoning.
- Do not wipe protective grease coating off of components before seasoning. This coating provides a more durable burn-in protective layer.

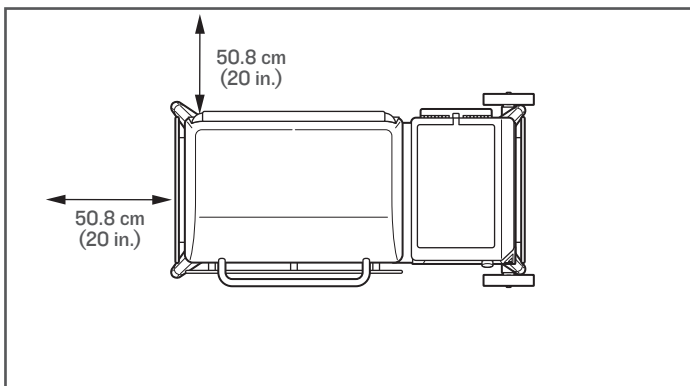

⚠️ WARNING Fire Hazard

- When operating your Traeger Grill, maintain a **MINIMUM** distance of 50.8 cm (20 inches) from the grill to any nearby combustibles, including wooden railings, home siding, window frames, furniture, trees, trash receptacles, etc.

⚠️ DANGER Carbon Monoxide Hazard

Burning wood pellets produces carbon monoxide which may lead to illness, serious injury, and/or death. Follow these guidelines to prevent this colorless, odorless gas from poisoning you, your family, your pets, or others:

- Only use your Traeger Grill outside in a well-ventilated area. This grill is intended for **OUTDOOR USE ONLY**.
- **Never** use your Traeger Grill in any enclosed area or any area without adequate ventilation.
- Know the symptoms of carbon monoxide poisoning: headache, dizziness, weakness, nausea, vomiting, sleepiness, and confusion. Carbon monoxide reduces the blood's ability to carry oxygen. Low blood oxygen levels can result in loss of consciousness and death.
- See a doctor if you or others develop cold- or flu-like symptoms while cooking or in the vicinity of this appliance. Carbon monoxide poisoning, which can easily be mistaken for a cold or flu, is often detected too late.
- Alcohol consumption and drug use increase the effects of carbon monoxide poisoning.
- Carbon monoxide is especially toxic to mother and child during pregnancy, infants, the elderly, smokers, and people with blood or circulatory system problems, such as anemia or heart disease.

⚠️ WARNING Fire Hazard

- **Never** use gasoline, lantern fuel, kerosene, lighter fluid, or other flammable materials to start or "freshen up" a fire.
- **Never** use or store flammable liquids or other combustibles materials near the grill.

⚠️ WARNING Burn Hazard

Ashes should always be completely cool before handling. Ashes should be placed in a metal container with a tight-fitting lid. The closed container of ashes should be placed on a noncombustible floor or on the ground, well away from all combustible materials, pending final disposal. Ashes should be retained in the closed container until they are disposed of.

⚠️ WARNING Do Not Use Fuel Pellets

Never use heating fuel pellets in the grill because they may contain hazardous contaminants and additives and may damage the grill.

SEASONING YOUR GRILL CONTINUED

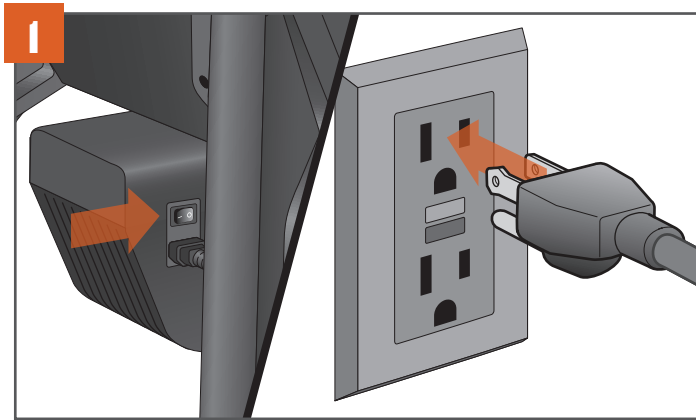

With the main power switch set to OFF (0), connect the power cord to your grill. Then plug the power cord into a properly grounded/earthed electrical outlet protected by a Ground Fault Circuit Interrupter (GFCI).

NOTE: Plug appearance may vary by region.

WARNING! ELECTRICAL SHOCK HAZARD
HAZARDOUS VOLTAGE IS PRESENT, WHICH CAN SHOCK, BURN, OR CAUSE DEATH.

- GROUND FAULT CIRCUIT INTERRUPTER (GFCI) PROTECTION MUST BE PROVIDED ON THE CIRCUIT(S) OR OUTLET(S) TO BE USED FOR THE OPERATION OF THIS TRAEGER GRILL.

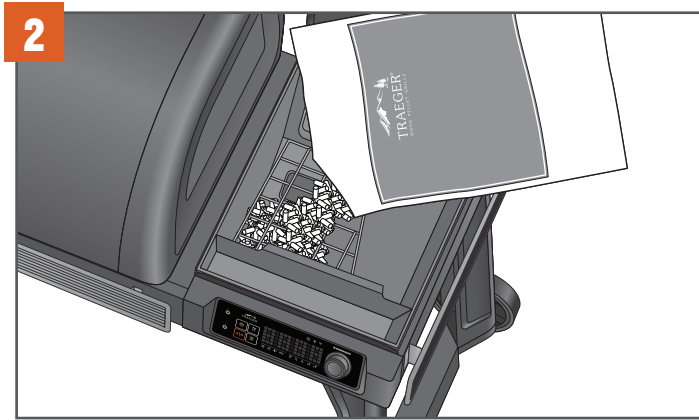

To add pellets, open the hopper lid and inspect for any foreign objects in the auger. Fill the hopper with pellets at least to the safety grate and close the lid.

USE ONLY TRAEGER HARDWOOD PELLETS. This product is developed and tuned using only Traeger pellets. Traeger pellets are crafted to meet strict quality and performance standards. Using pellets not manufactured by Traeger may result in inconsistent performance, poor flavor, and temperature inconsistency.

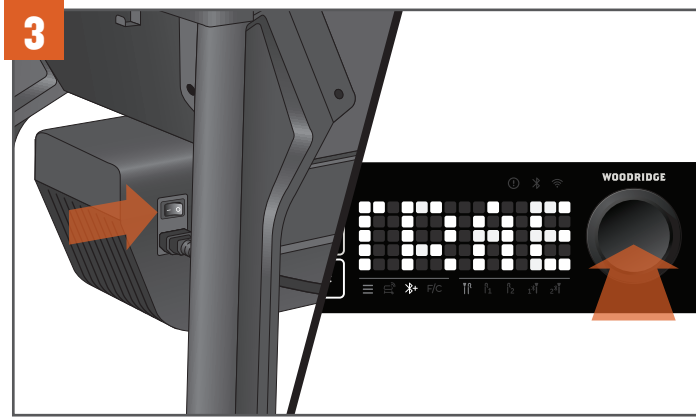

Press the main power switch, located on the back of the auger box, to ON (I). Press the selection dial to wake up the controller. "TRAEGER" will scroll across the screen, indicating the grill is on.



Turn the selection dial to set the grill's temperature to 350°F (177°C), then press the dial. Press the ignite/shutdown button.

PRO TIP: This seasoning process is important to ensure proper grill performance. Make sure that all internal components have been properly installed prior to this seasoning cycle and that there is no food on the grill grates during this process.



The grill temperature will display as it increases to the set temperature.

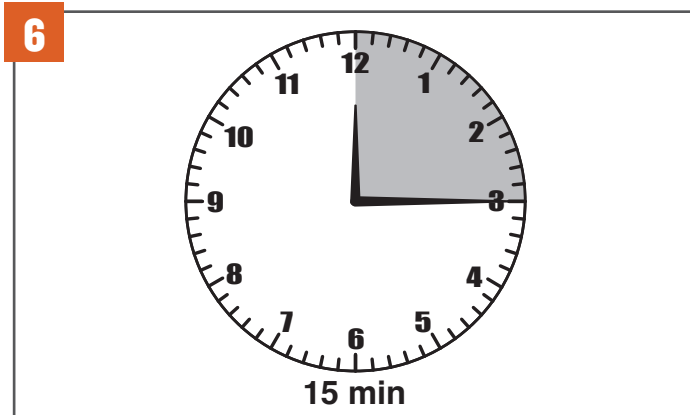

Once the grill has reached 350°F (177°C), let it run for 15 minutes. While the grill is seasoning, you may see dark or excessive smoke and ash; this is normal and will be less on future startups.



After 15 minutes at 350°F (177°C), increase the temperature to 500°F (260°C).

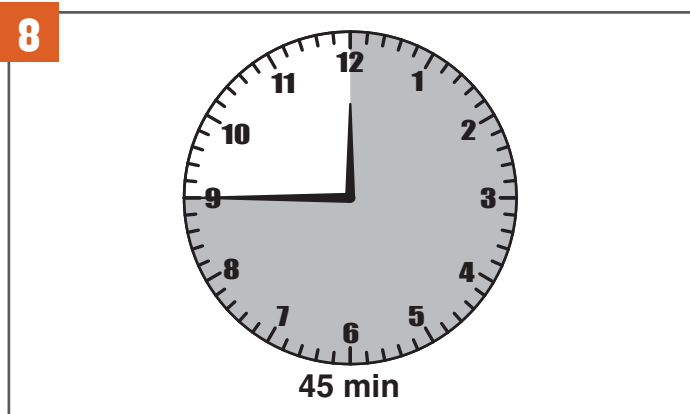

Once the grill has reached 500°F (260°C), let it run for another 45 minutes to ensure seasoning is completed properly.

NOTE: Getting to first-time seasoning temperature may take up to an hour.

SEASONING YOUR GRILL CONTINUED

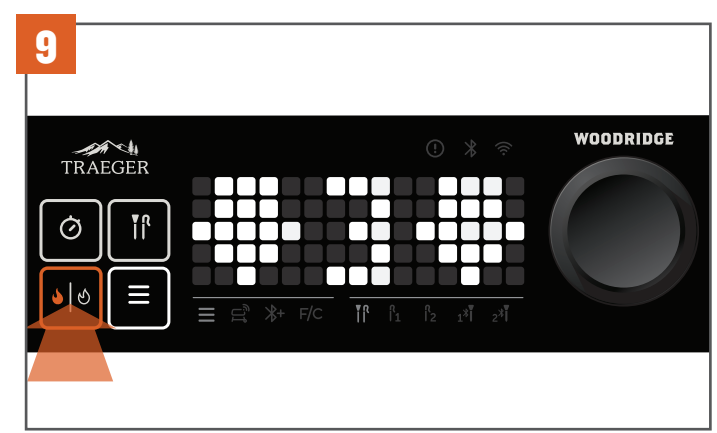

After 45 minutes at 500°F (260°C), shut down the grill and let the shutdown cycle complete. To shut down your grill, press and hold the ignite/shutdown button or the selection dial for three seconds until the display shows the shutdown animation.

NOTE: Always initiate a shutdown cycle after each and every cook.



A countdown timer begins while the grill is shutting down. You will hear the fan continue to run.

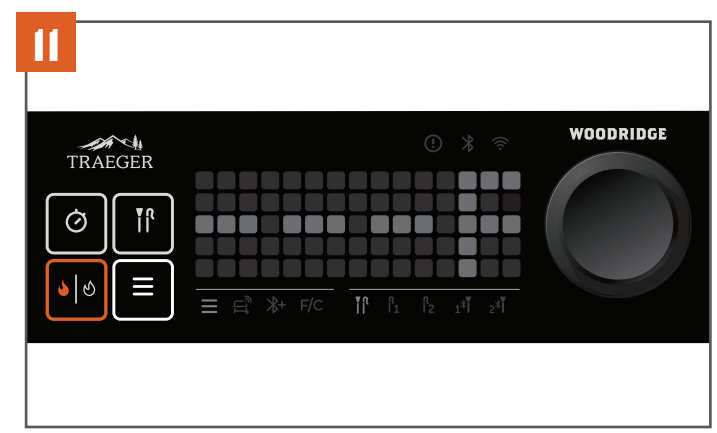

Once this countdown is complete, the shutdown cycle is complete.

NOTE: It is normal to observe ash on the drip tray and/or grill grates after seasoning. Simply wipe away ash on grill grates prior to your first cook.

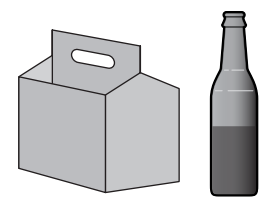



NOTES







GUIDE DE MONTAGE

BARBECUE À GRANULES À BOIS WOODRIDGE



**SCANNEZ
POUR OBTENIR
DES INSTRUCTIONS
ANIMÉES
ÉTAPE PAR ÉTAPE**

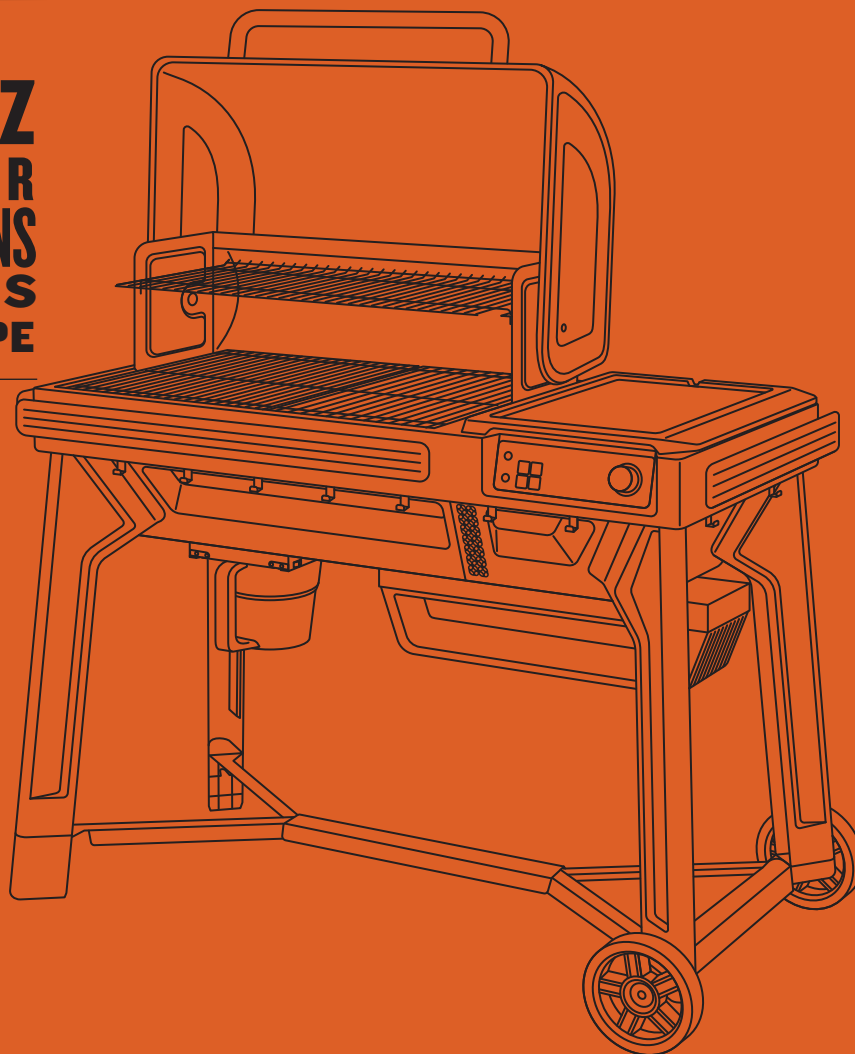
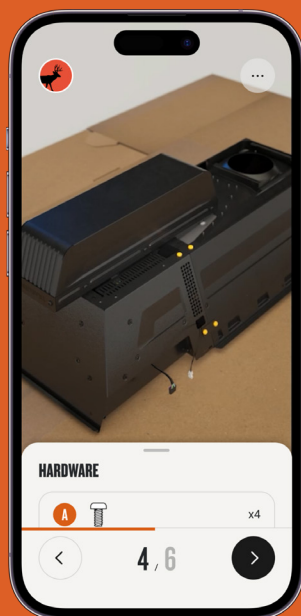

L'UNE DES PRINCIPALES CAUSES D'INCENDIE EST LE NON-RESPECT DES ESPACES REQUISES (ESPACES D'AIR) AVEC LES MATÉRIAUX COMBUSTIBLES. IL EST EXTRÊMEMENT IMPORTANT QUE CE PRODUIT SOIT INSTALLÉ CONFORMÉMENT À CES INSTRUCTIONS.

IMPORTANT : À CONSERVER. LIRE ATTENTIVEMENT.

T18983

©2025 TRAEGER PELLET GRILLS LLC.
TOUS DROITS RÉSERVÉS.

TRAERER PELLET GRILLS LLC

533 South 400 West
Salt Lake City, UT 84101

TRAERER.COM



AVANT DE COMMENCER LE MONTAGE

VEUILLEZ LIRE CE GUIDE DE MONTAGE ET VOTRE MANUEL DU PROPRIÉTAIRE AVANT L'INSTALLATION ET L'UTILISATION DE VOTRE BARBECUE TRAEGER. LE NON-RESPECT DES INSTRUCTIONS DE CE GUIDE DE MONTAGE ET DE VOTRE MANUEL DU PROPRIÉTAIRE PEUT ENTRAÎNER DES DOMMAGES MATÉRIELS, DES BLESSURES CORPORELLES, VOIRE LA MORT.

Lorsque vous utilisez votre barbecue, maintenez une distance MINIMALE de 50,8 cm (20 po) entre le barbecue et tout matériau combustible à proximité, notamment les rampes en bois, le revêtement extérieur de la maison, les cadres de fenêtres, les meubles, les arbres, les poubelles, etc. N'installez pas et n'utilisez pas ce barbecue sur des sols ou des surfaces combustibles, à l'intérieur, ni sous un plafond ou un surplomb combustible. Lisez le manuel d'utilisation pour obtenir des instructions et des avertissements supplémentaires.

ESPACE D'INSTALLATION

 **CONSEIL DE PRO :** construisez sur le plateau inférieur de la boîte d'expédition pour éviter les rayures.

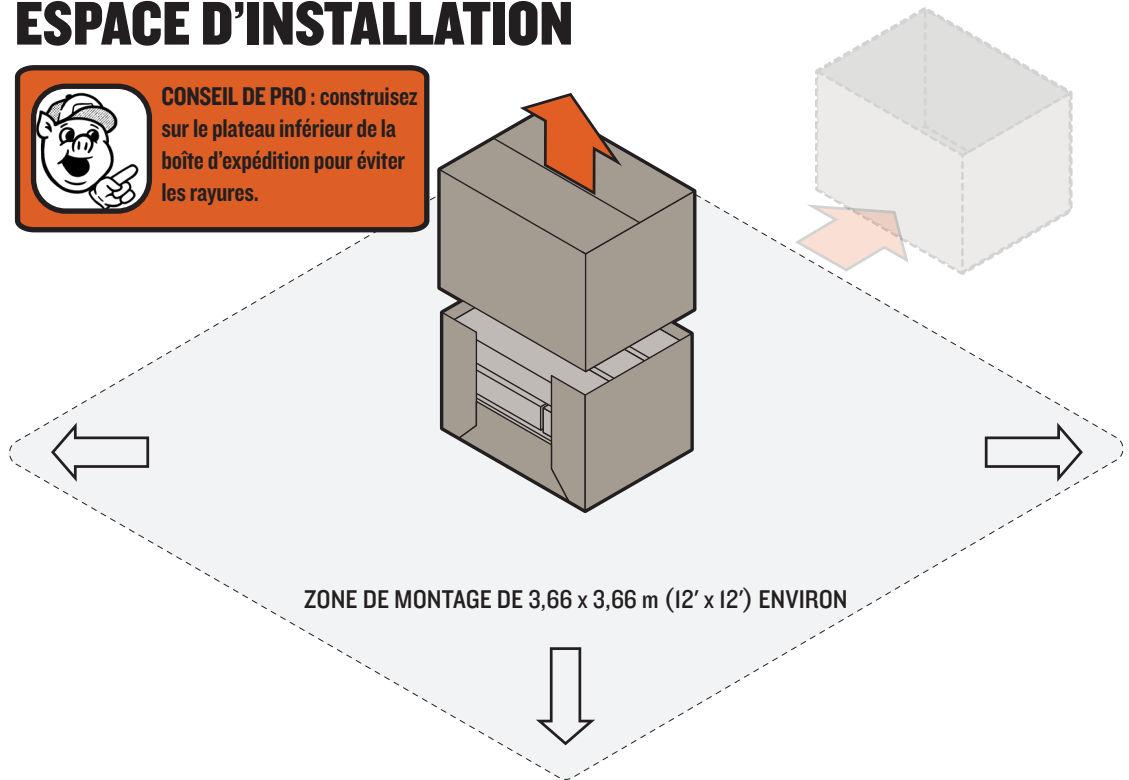

 **CONSEIL DE PRO :** nous vous recommandons de monter votre barbecue avec deux personnes.

INSTALLATION

Une fois tous les composants déballés, disposez les pièces sur le plateau inférieur de la boîte d'expédition.

REGROUPEZ LES BOÎTES EN FONCTION DE LEURS SYMBOLES D'IDENTIFICATION, COMME INDIQUÉ CI-DESSOUS :



COMPARTIMENTS ET PIEDS



ROUES ET SABOTS



COMMANDES ET ÉTAGÈRES



COUVERCLE ET COMPOSANTS INTERNES DU BARBECUE

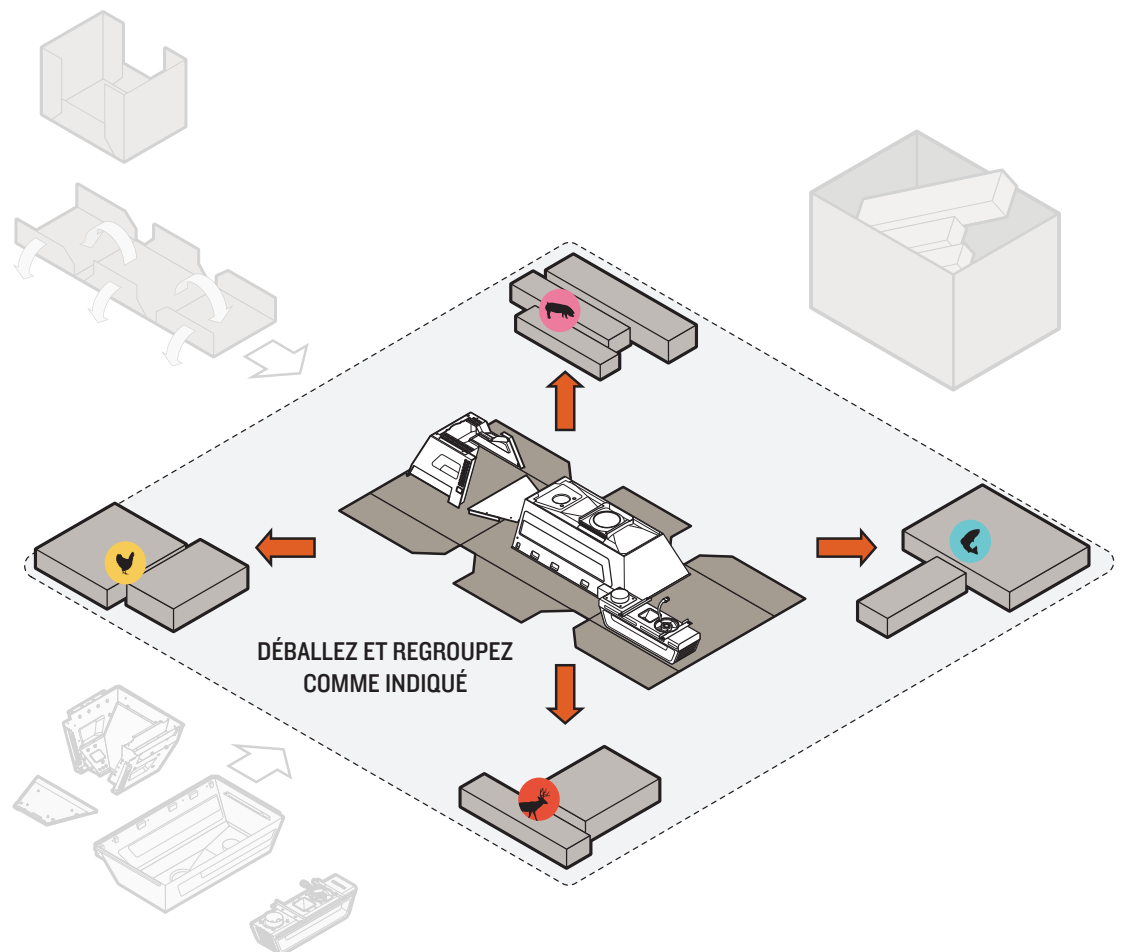



MATÉRIEL (QUANTITÉS TOTALES)

ÉCHELLE 1:1

A

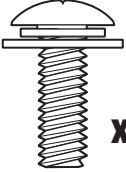

x32 x2 extra

1/4
20
0,75 po

B

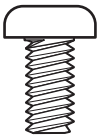

x61 x4 extra

1/4
20
0,5 po

C



x4

PLAQUE DE MONTAGE

D

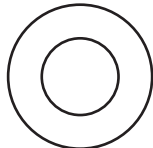

x2

0,375
RONDELLE

E



x2 x1 extra

GOUPILLE FENDUE RONDE

F



x2

0,375
GOUPILLE À ÉPAULEMENT

G

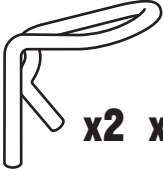

x2 x1 extra

120°
GOUPILLE FENDUE

H



x2 extra

PARE-CHOC EN SILICONE



CHAPITRES

CHAPITRE 1 – PAGE 5

COMPARTIMENTS ET PIEDS

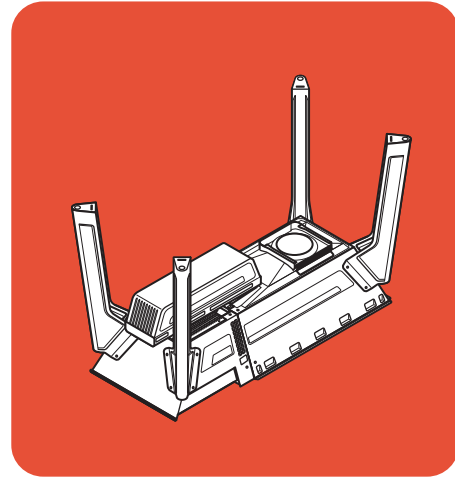

CHAPITRE 2 – PAGE 13

ROUES ET SABOTS

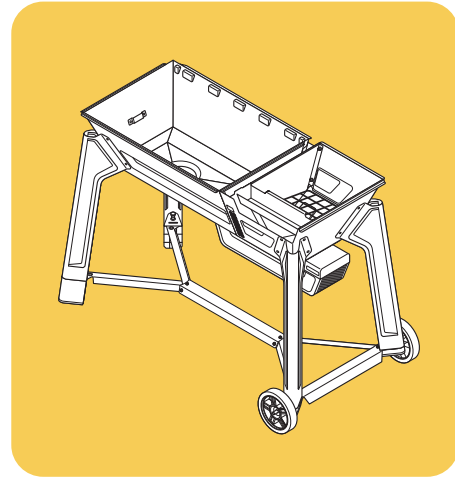

CHAPITRE 3 – PAGE 19

COMMANDES ET ÉTAGÈRES

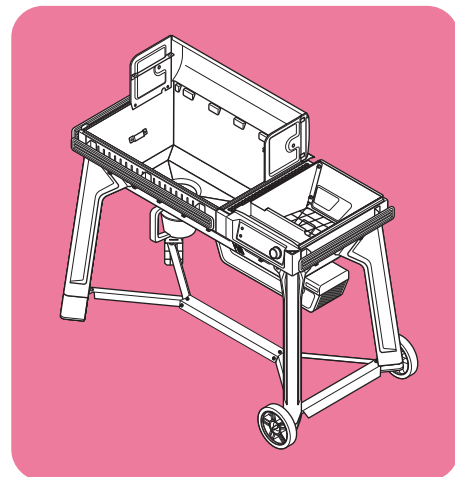

CHAPITRE 4 – PAGE 31

**COUVERCLE ET COMPOSANTS
INTERNES DU BARBECUE**

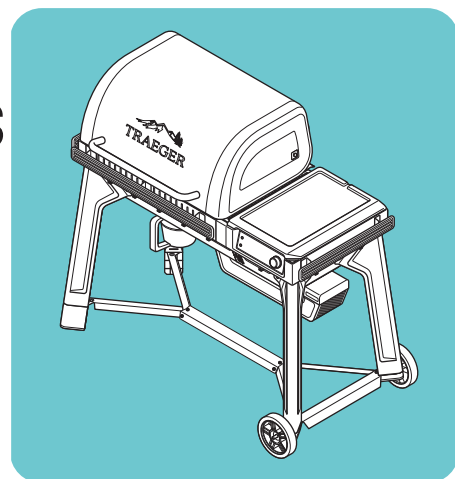

CHAPITRE 1

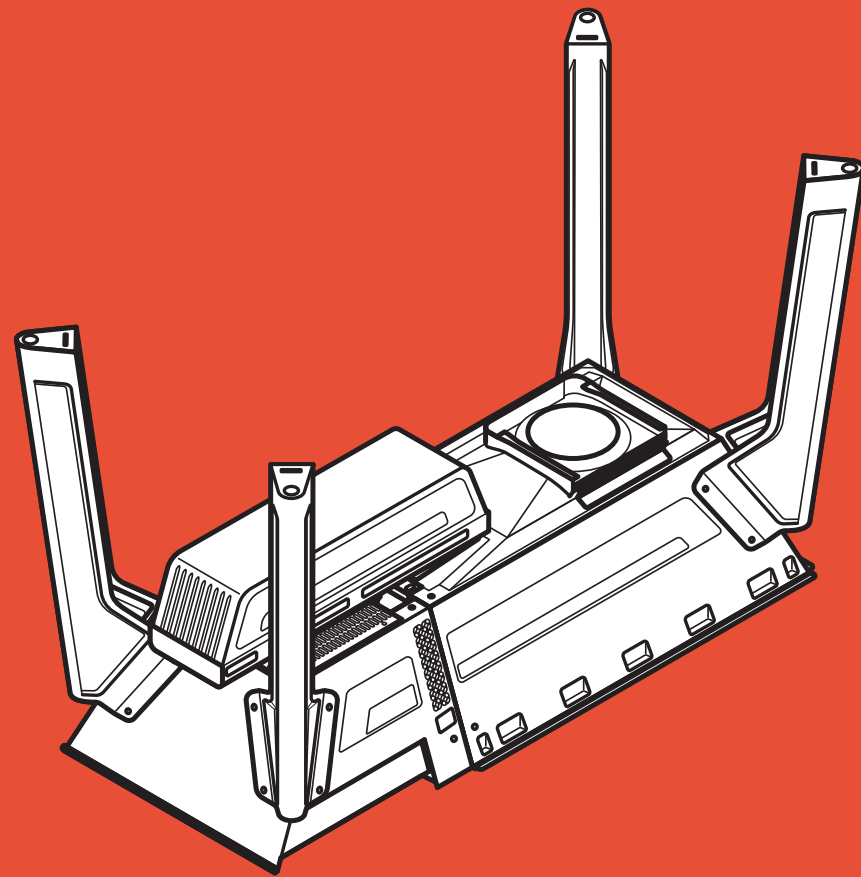

COMPARTIMENTS ET PIEDS

CHAPITRE 1

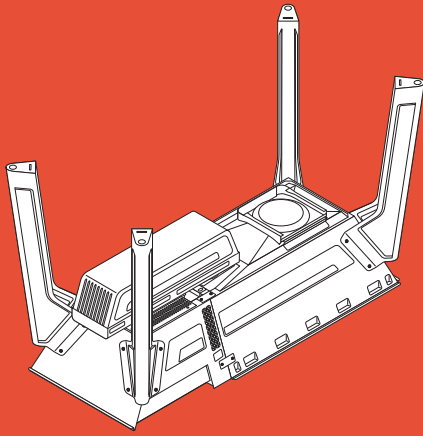

1 INSTALLER LA GRILLE DE SÉCURITÉ

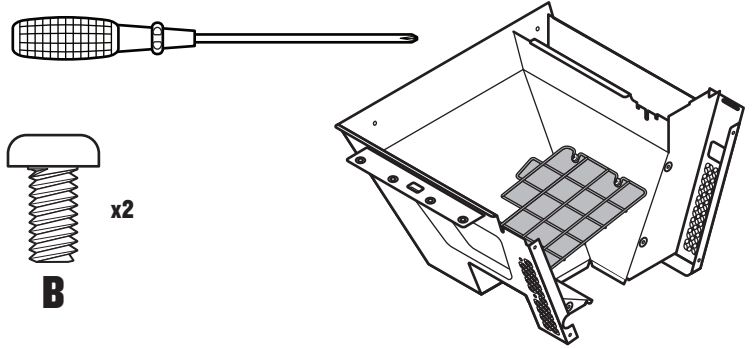

CONSEIL DE PRO : serrez d'abord toutes les vis à la main, puis terminez le serrage avec un tournevis.

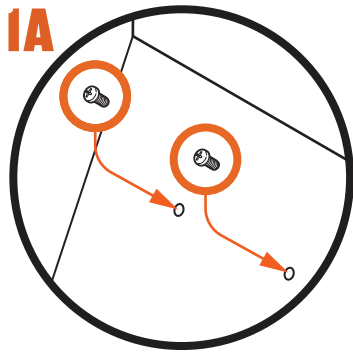

1B

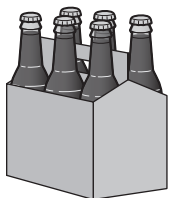
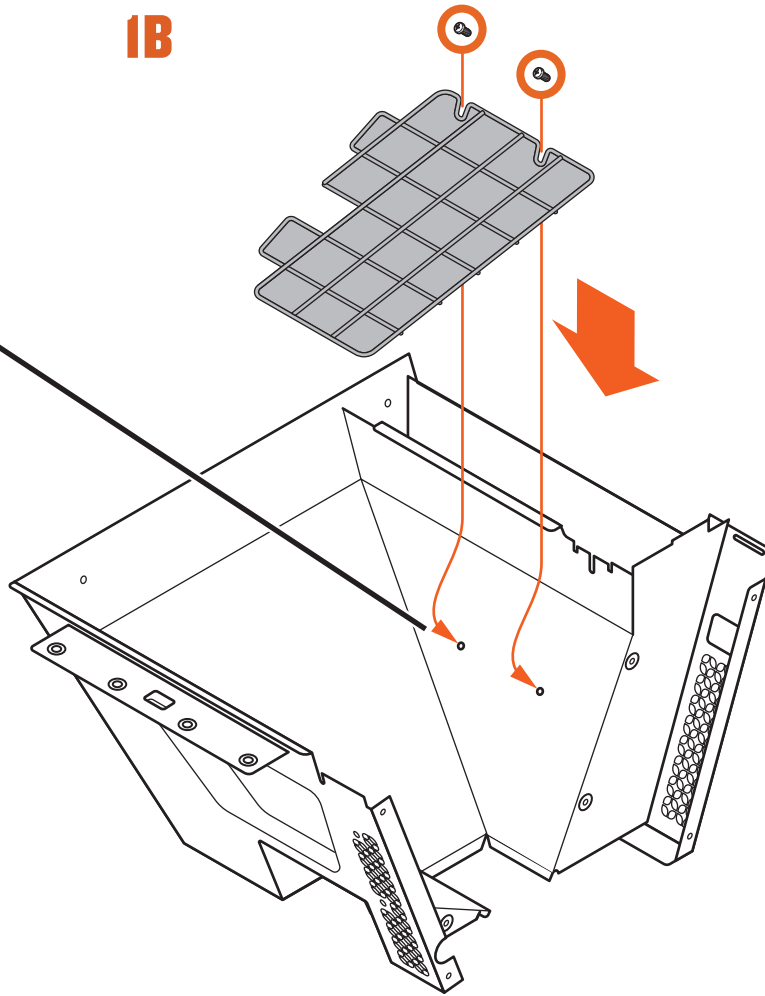

6



2 MONTER LA TRÉMIE

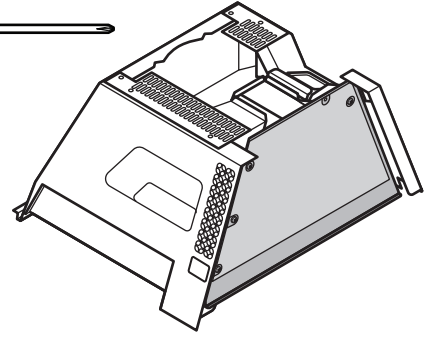
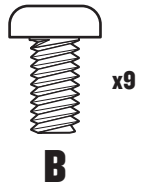
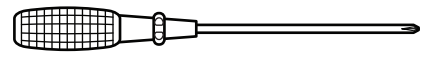

2A

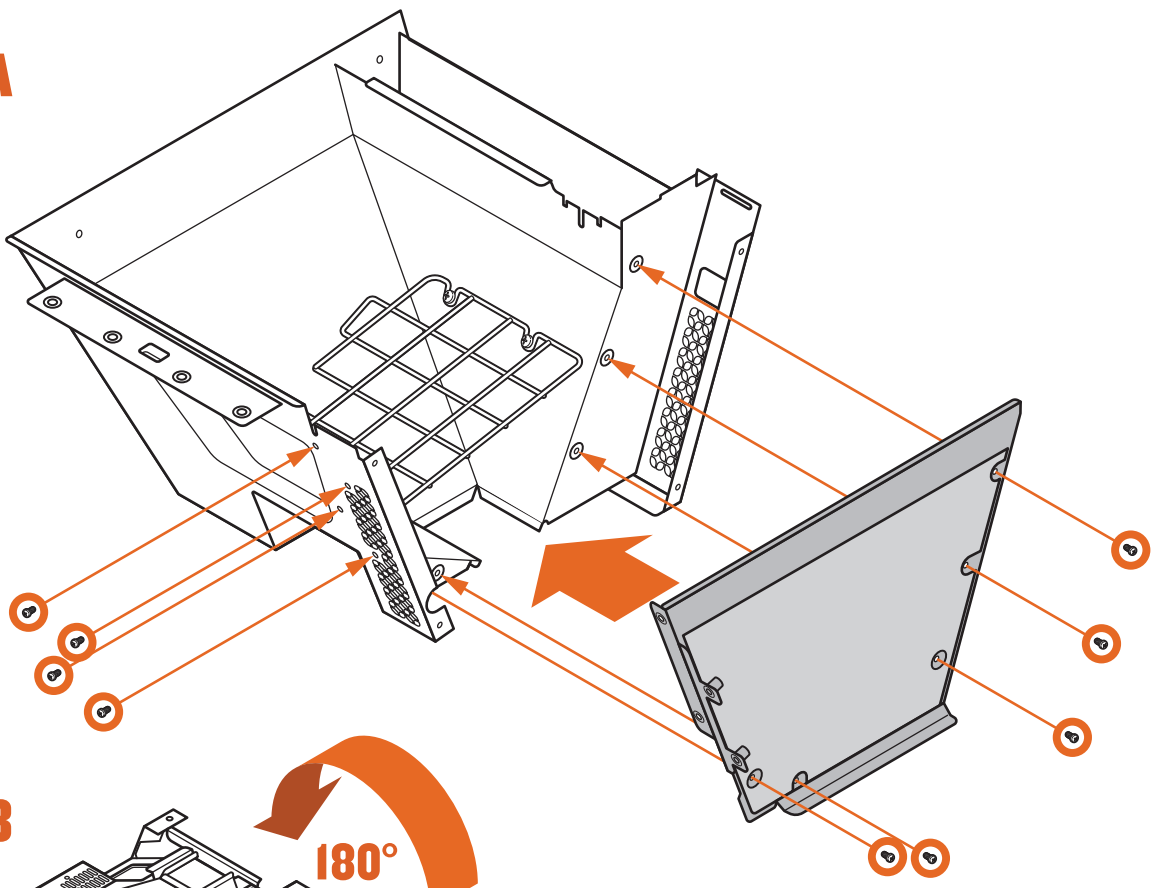

2B

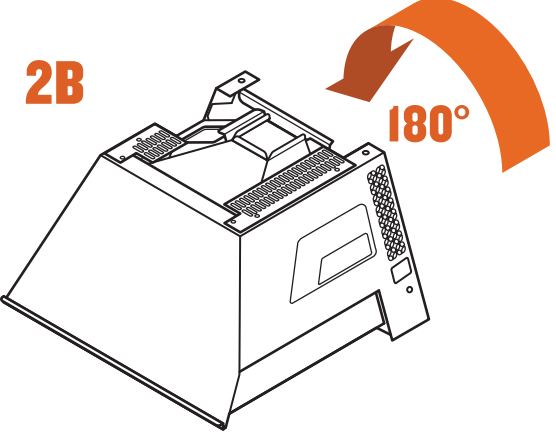



3A FIXER LA TRÉMIE AU CORPS

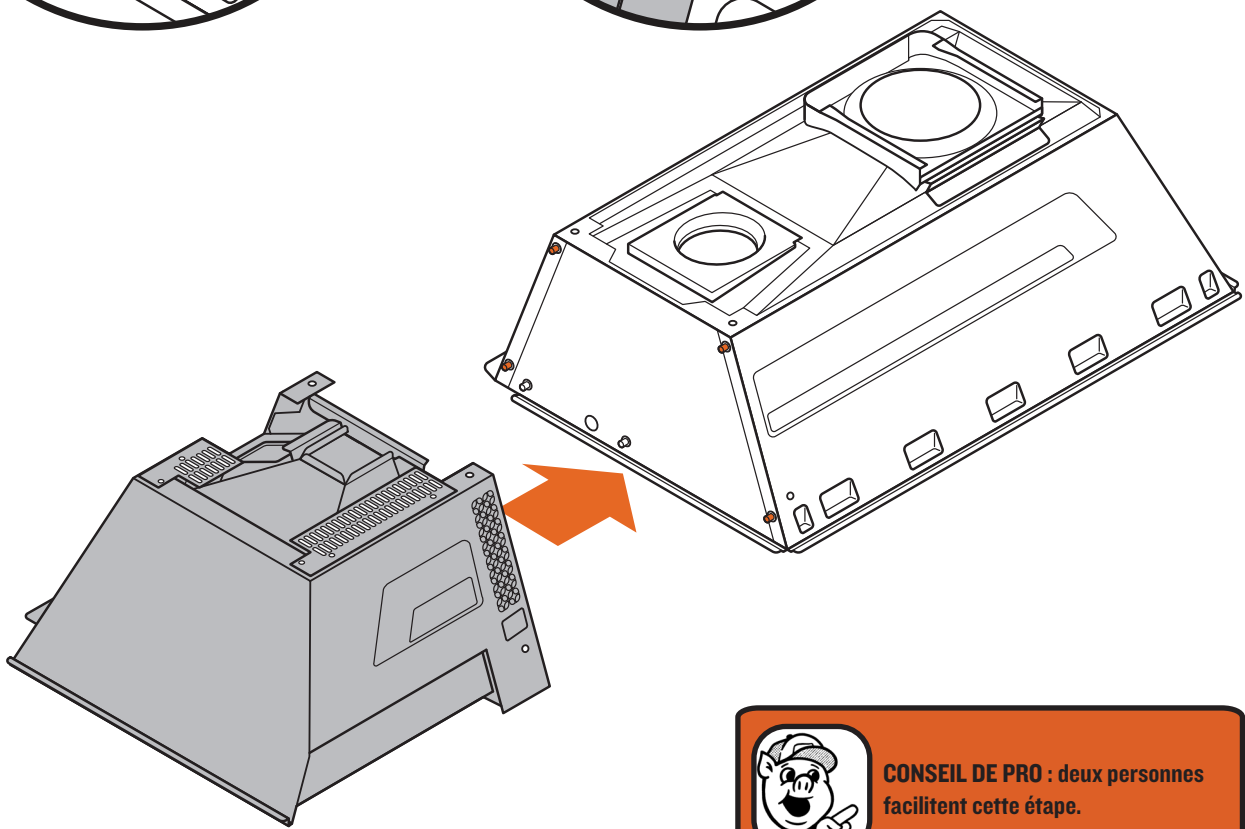
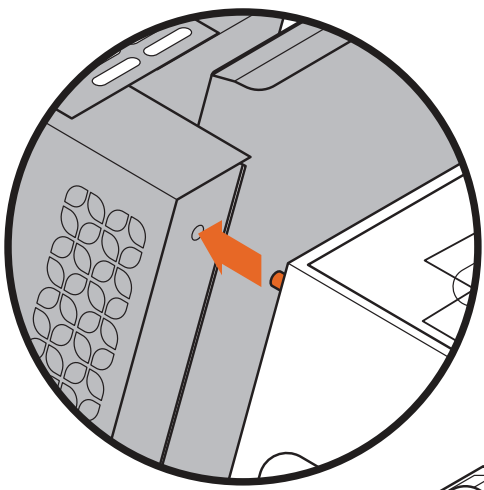
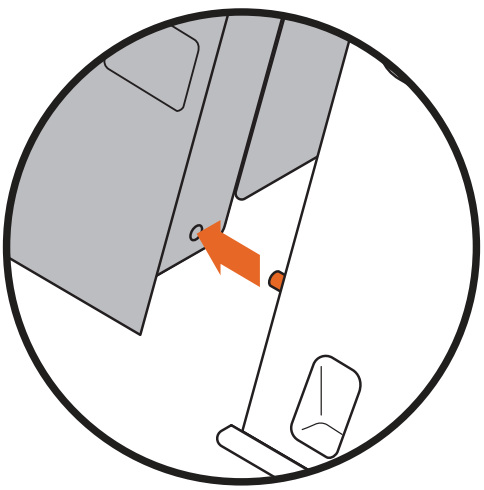
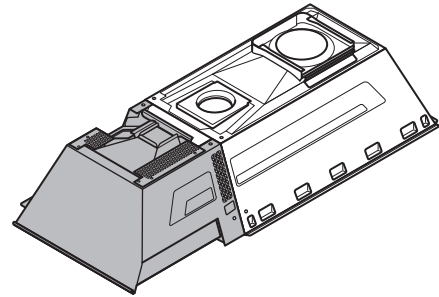

 **CONSEIL DE PRO** : deux personnes facilitent cette étape.





3B FIXER LA TRÉMIE AU CORPS

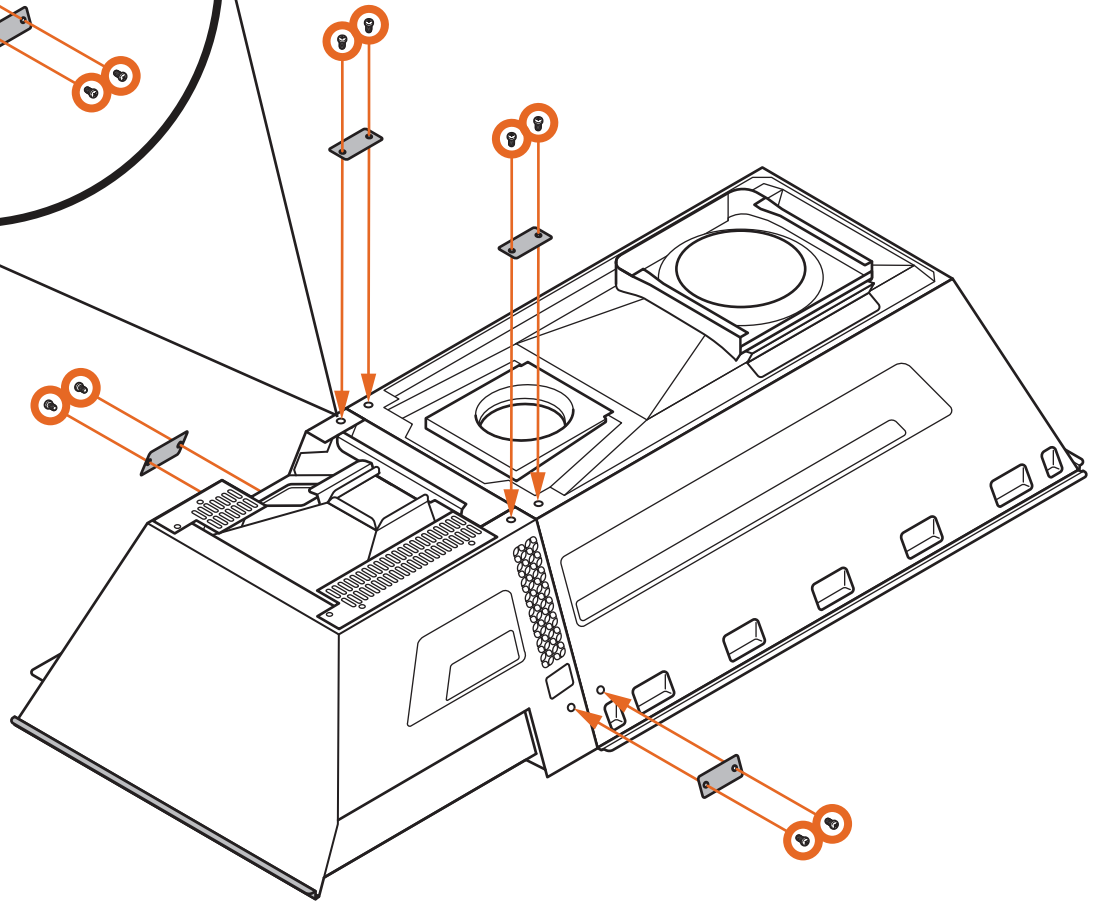
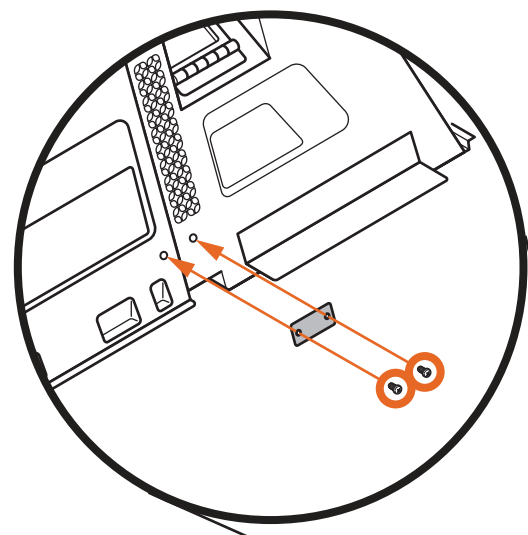
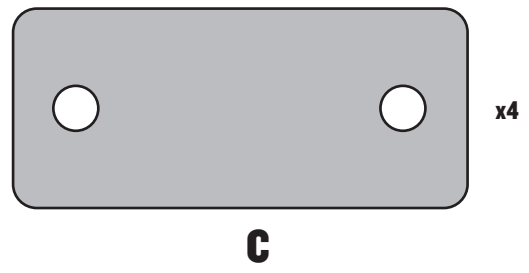
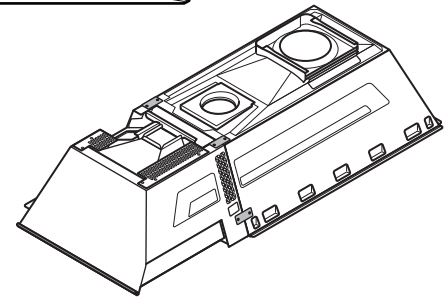
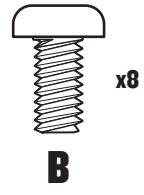
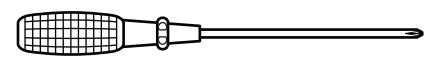



4 CONNECTER LE BOÎTIER DE LA VIS SANS FIN



CONNECTEUR À 12 BROCHES

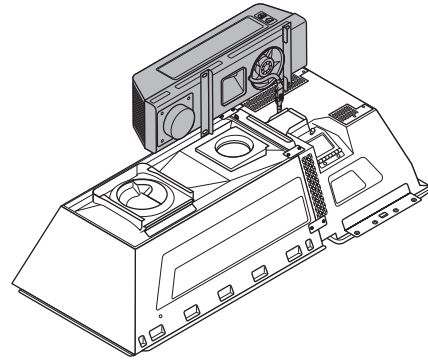
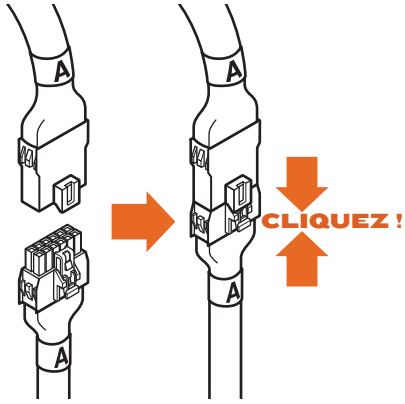
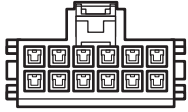

CONSEIL DE PRO : demandez à une deuxième personne de tenir le boîtier de la vis sans fin pendant que vous branchez le cordon.



CONSEIL DE PRO : n'oubliez pas de retirer le lien torsadé et le ruban adhésif qui maintiennent le cordon.

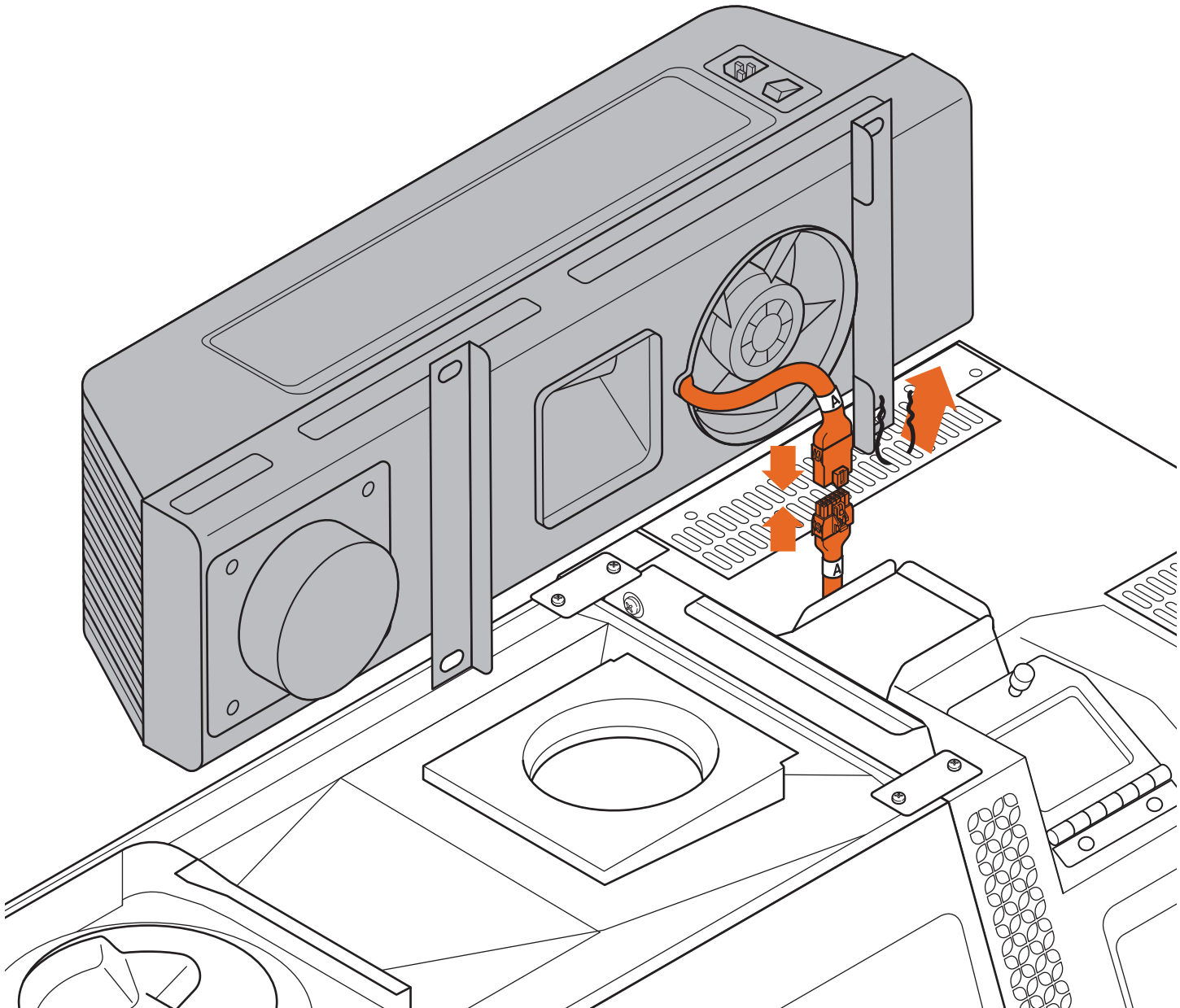



5 FIXER LE BOÎTIER DE LA VIS SANS FIN DE LA VIS SANS FIN

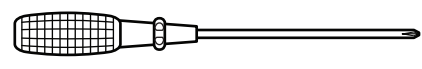

Utilisez CETTE vis maintenant !

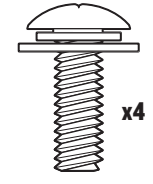

A

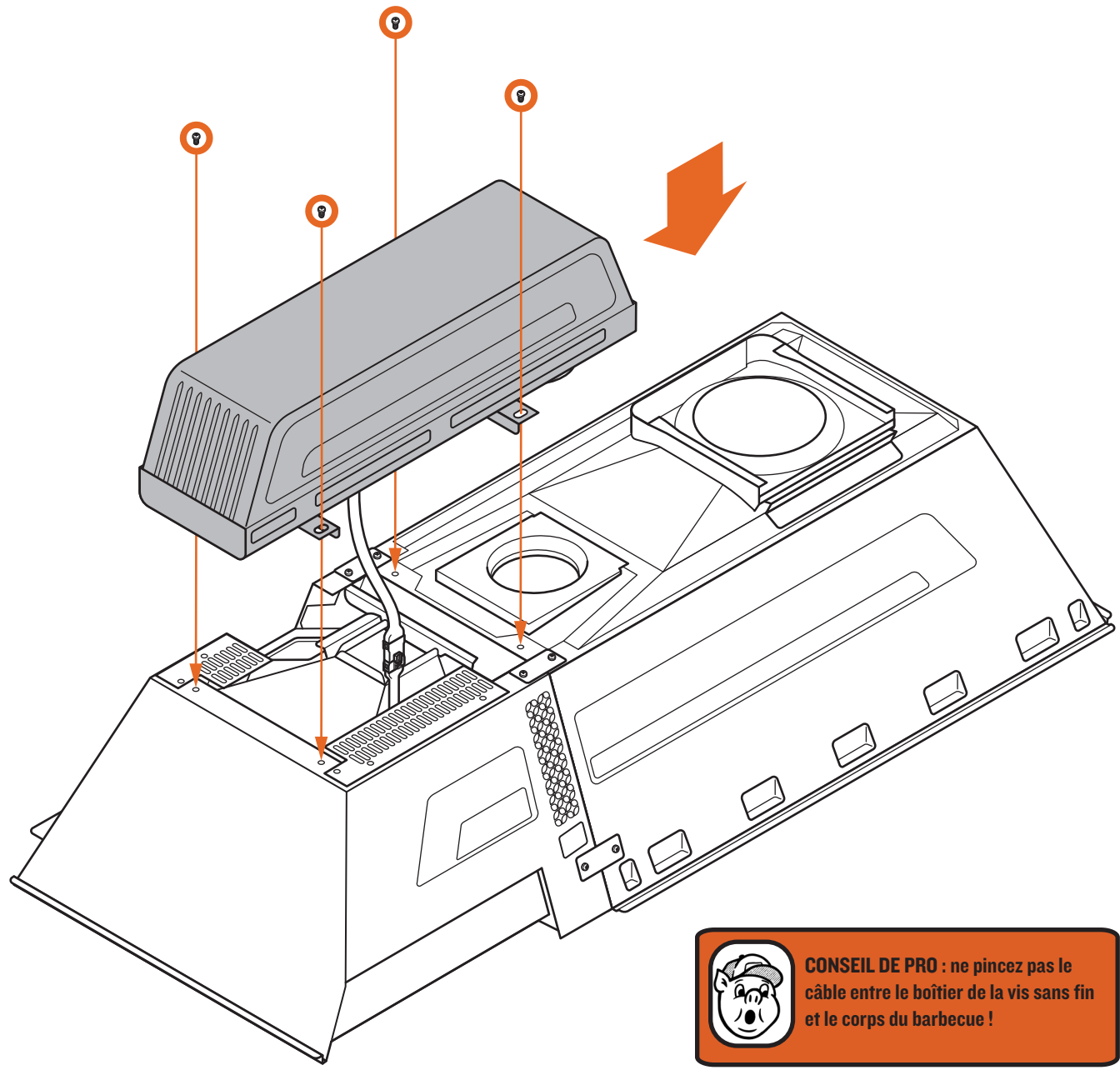
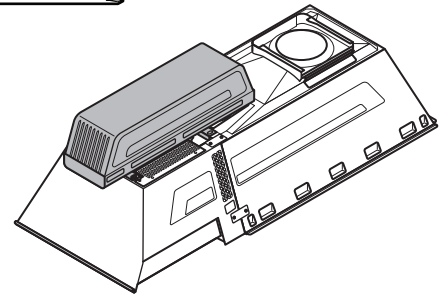

CONSEIL DE PRO : ne pincez pas le câble entre le boîtier de la vis sans fin et le corps du barbecue !



6 FIXER LES PIEDS

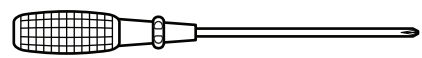

Utilisez **CETTE** vis encore une fois !

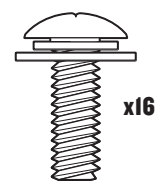

A

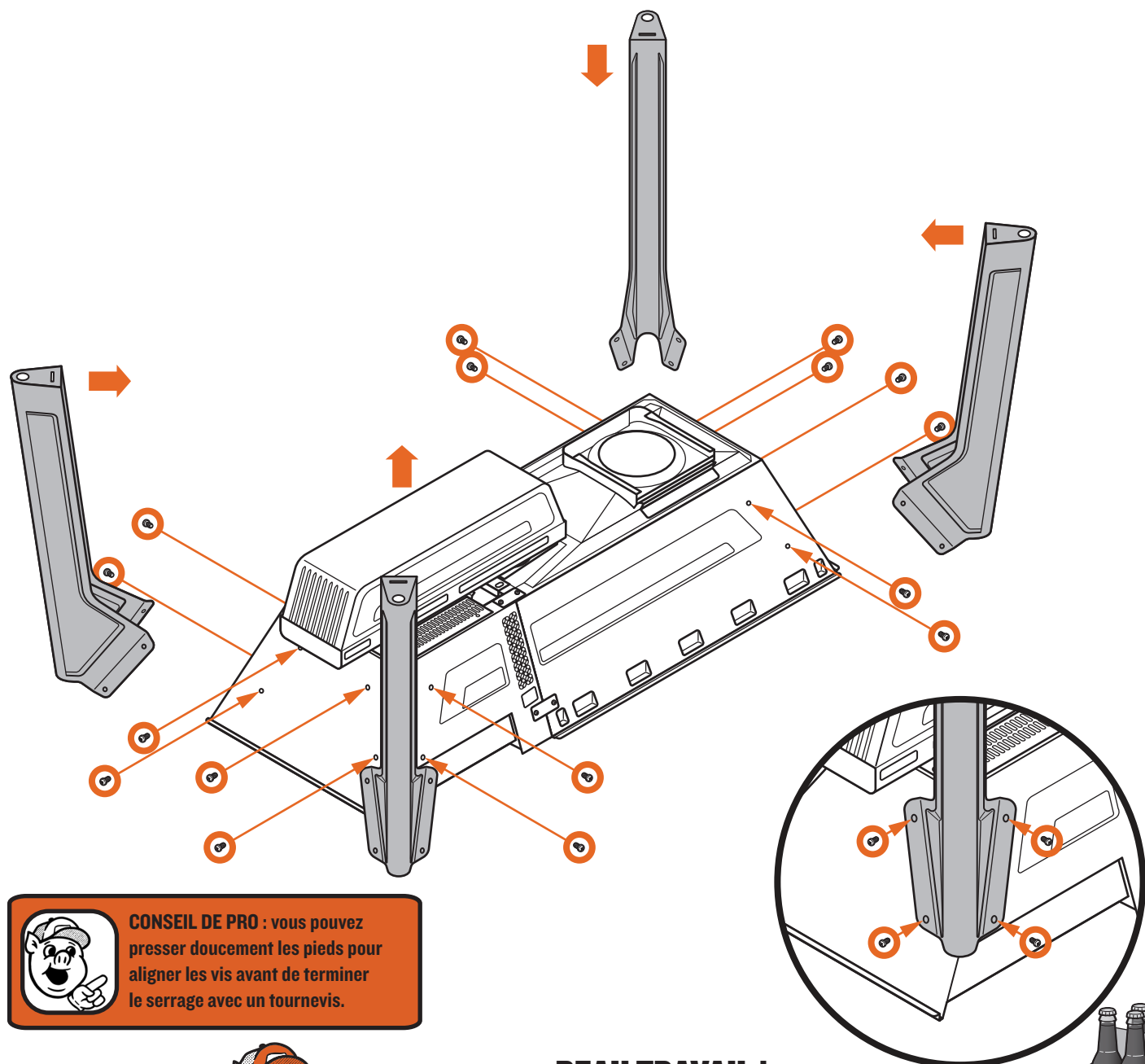
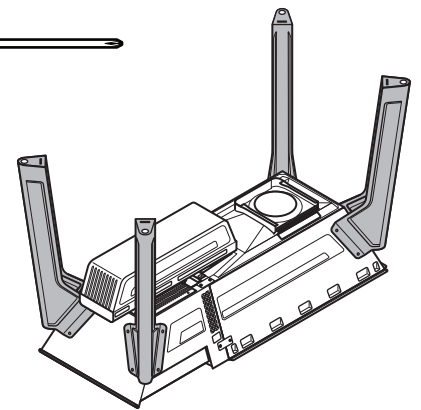

 **CONSEIL DE PRO :** vous pouvez presser doucement les pieds pour aligner les vis avant de terminer le serrage avec un tournevis.

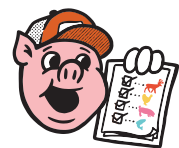

**BEAU TRAVAIL !
CHAPITRE I TERMINÉ !**

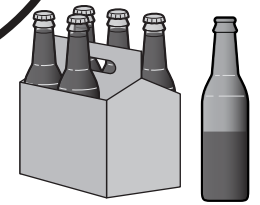

CHAPITRE 2

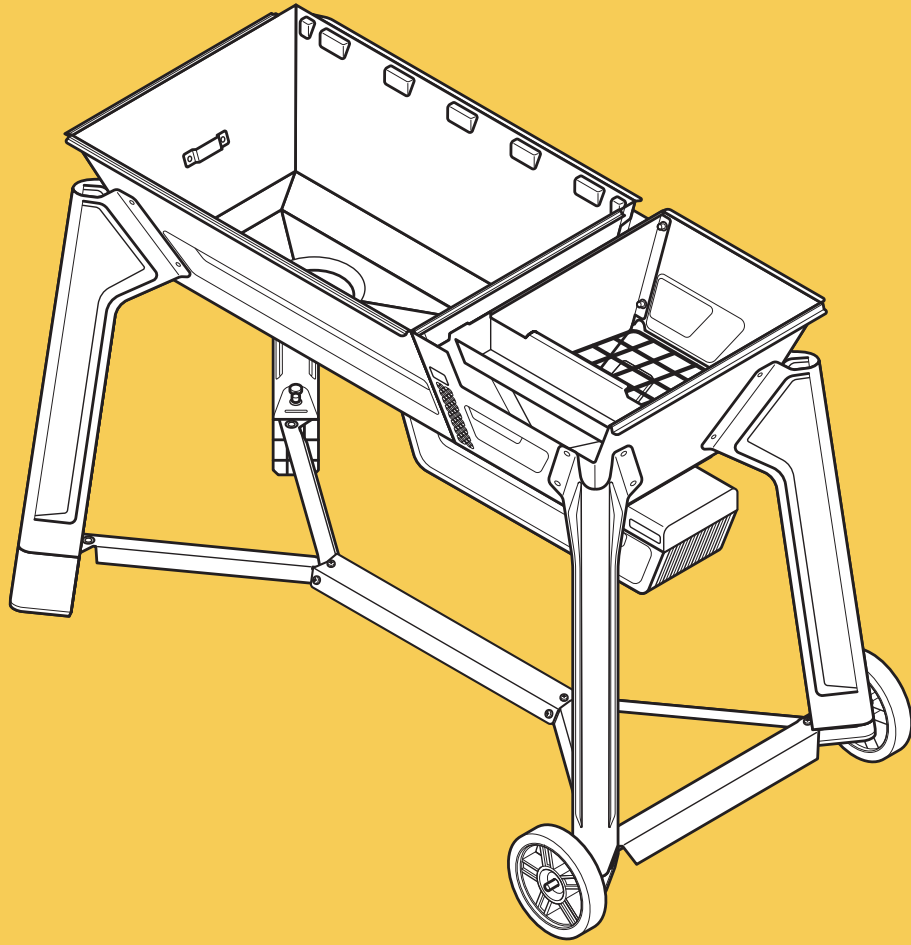

ROUES ET SABOTS

CHAPITRE 2

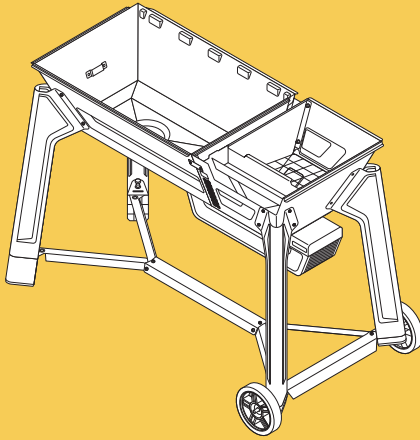

1 MONTER LE SUPPORT / CAPOT D'ESSIEU

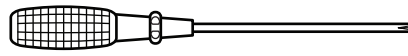

Utilisez **CETTE** vis encore une fois !

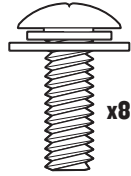

A

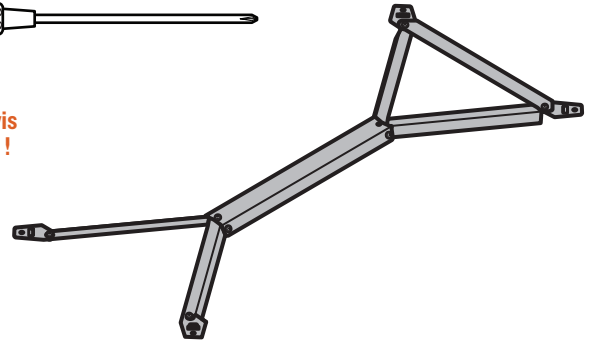

CONSEIL DE PRO : serrez d'abord toutes les vis à la main, puis terminez le serrage avec un tournevis.

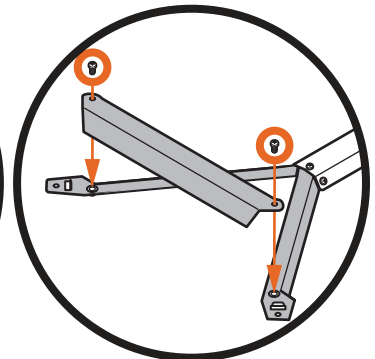
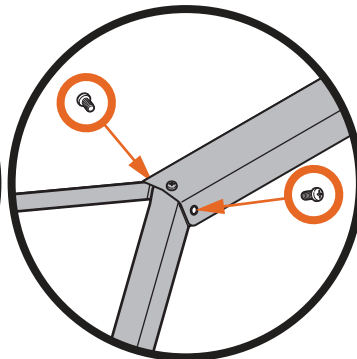
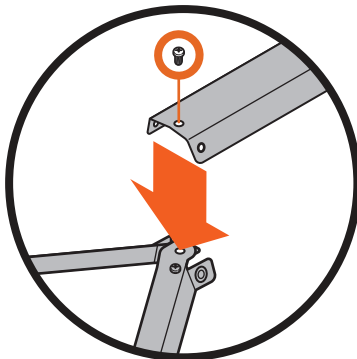
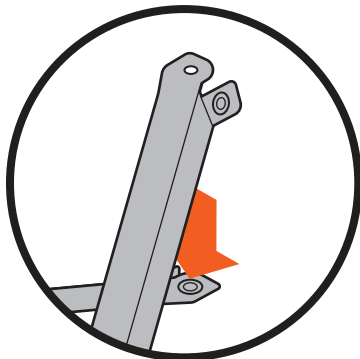
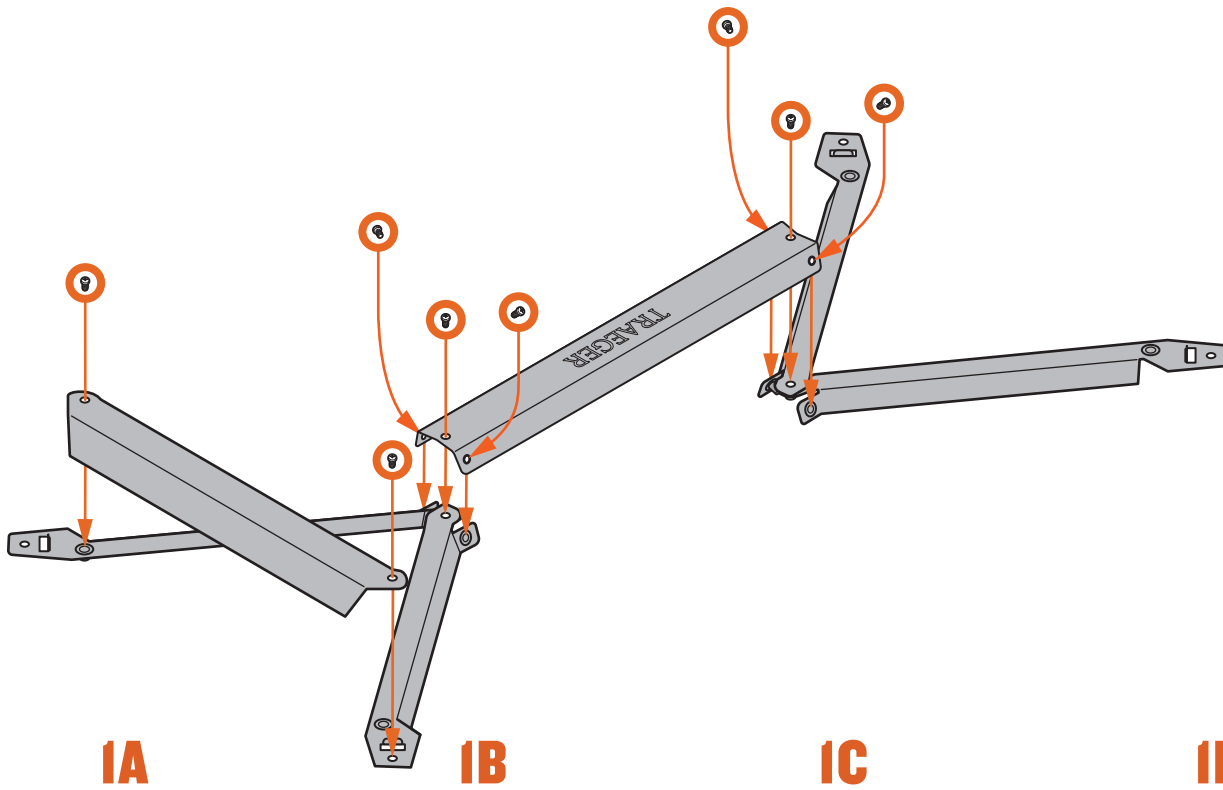



2 FIXER LE SUPPORT / CAPOT D'ESSIEU

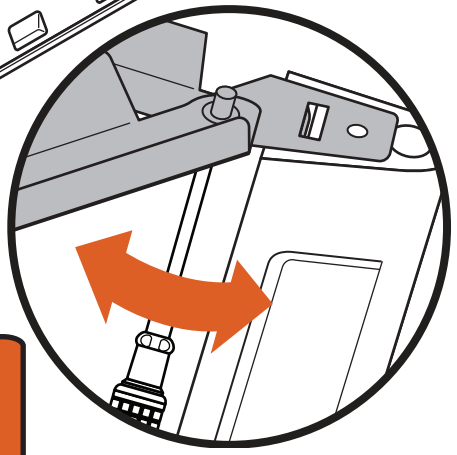
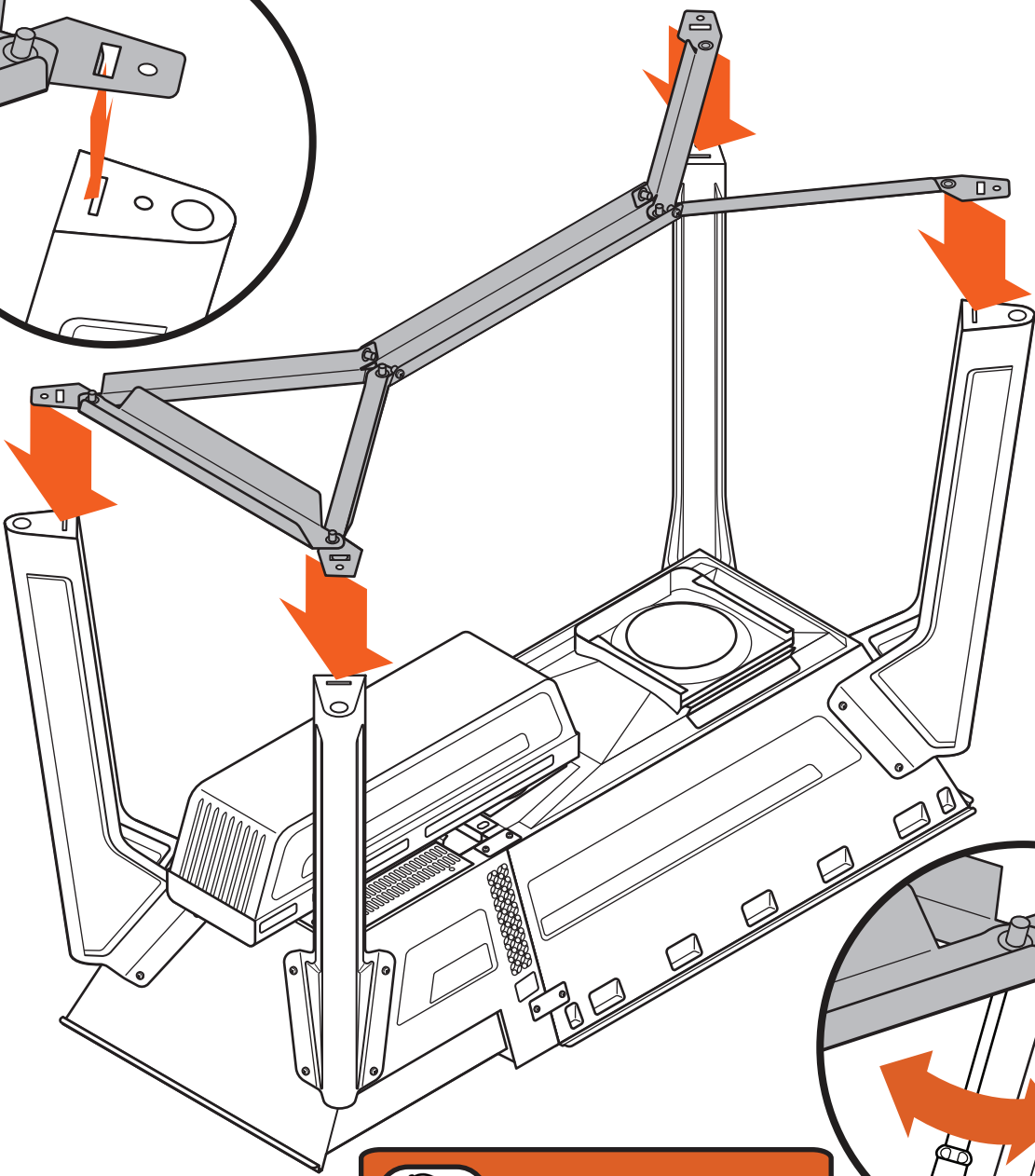
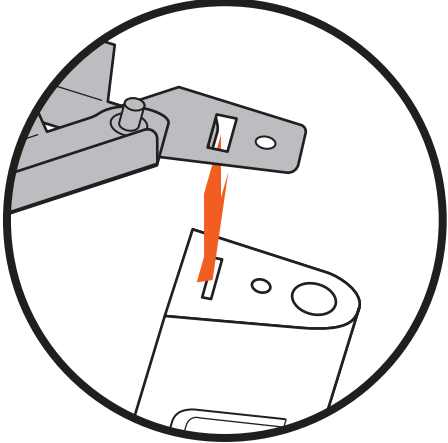
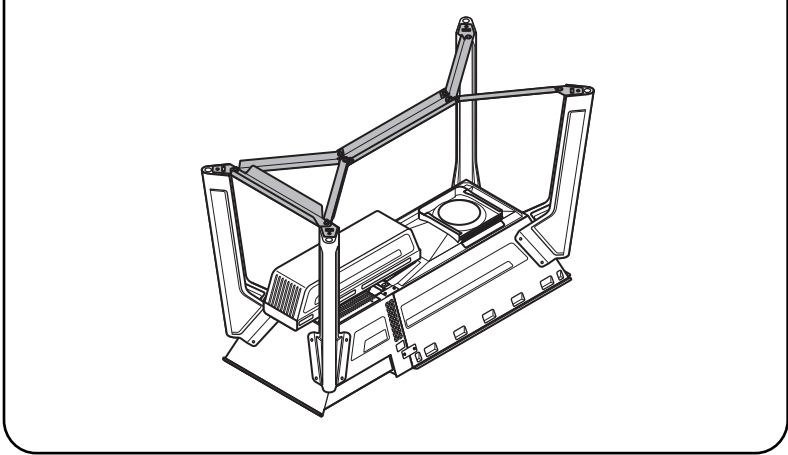
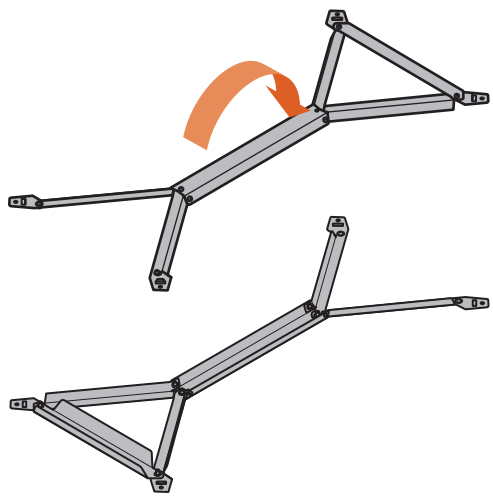

CONSEIL DE PRO : pour régler le support, desserrez et serrez les vis selon les besoins.

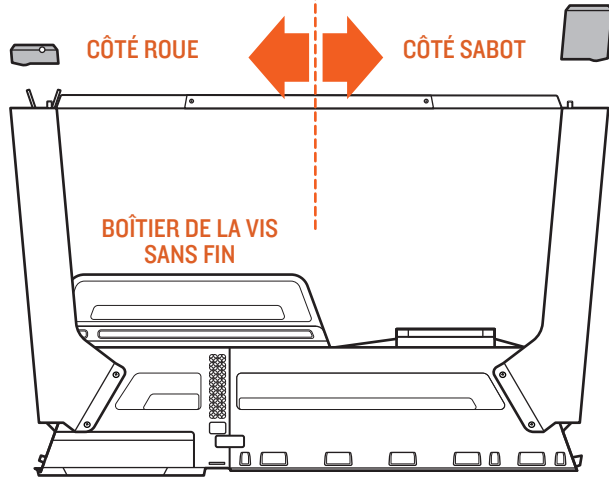

3 FIXER LES SABOTS DES ROUES

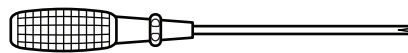

Utilisez **CETTE** vis encore une fois !

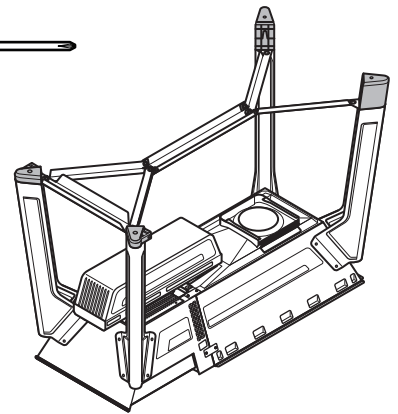
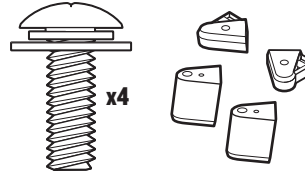

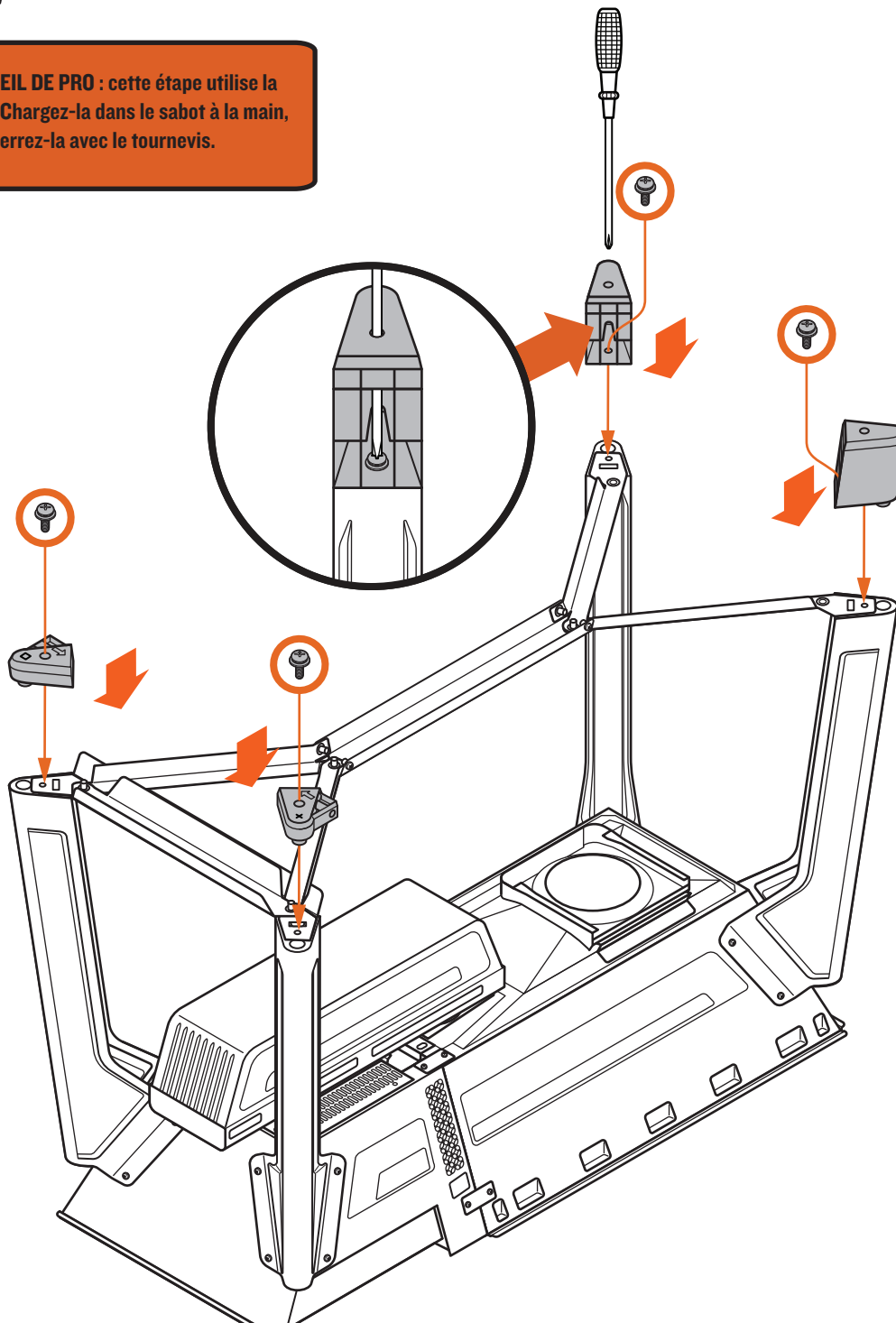

CONSEIL DE PRO : cette étape utilise la vis A. Chargez-la dans le sabot à la main, puis serrez-la avec le tournevis.



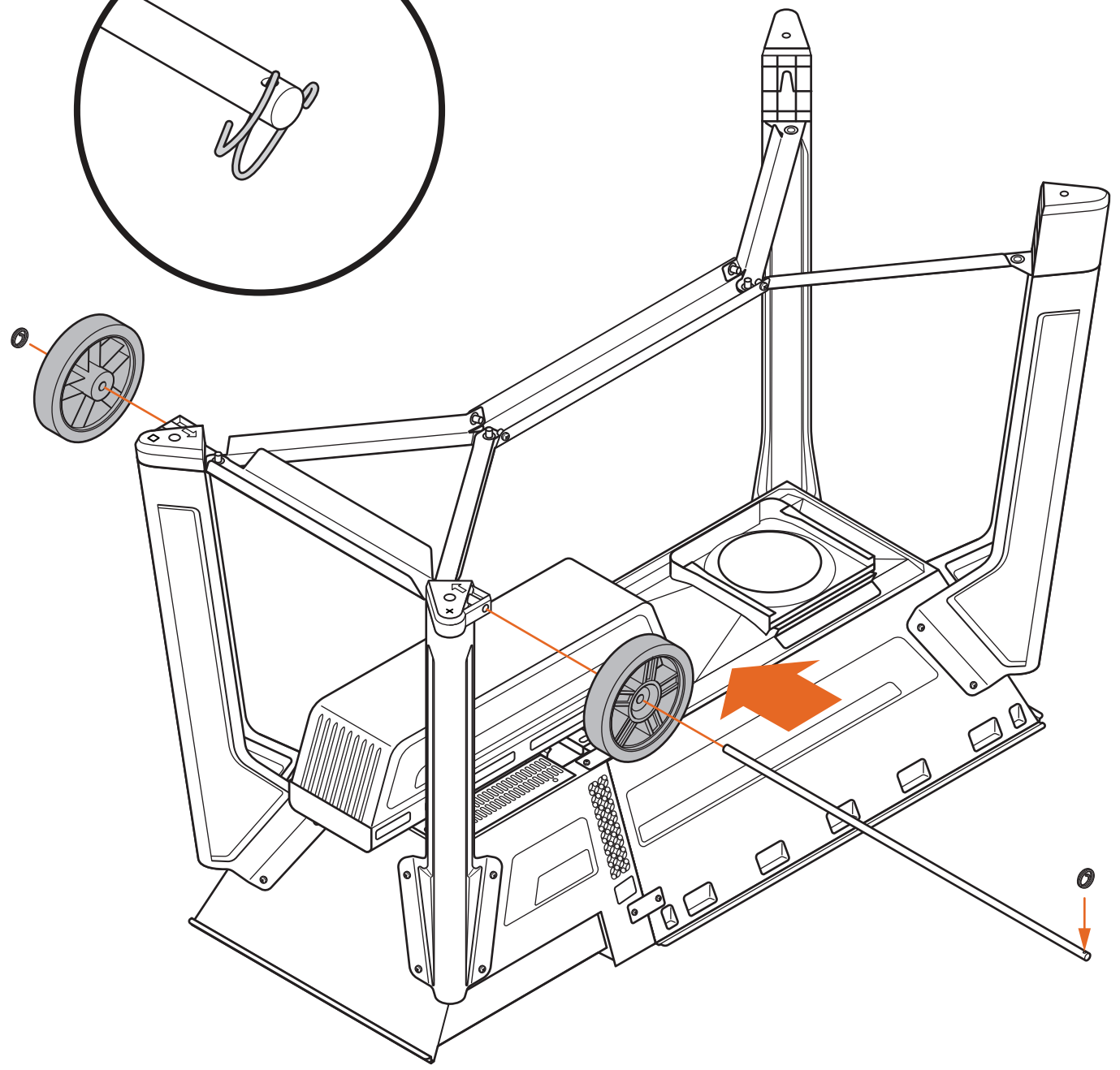
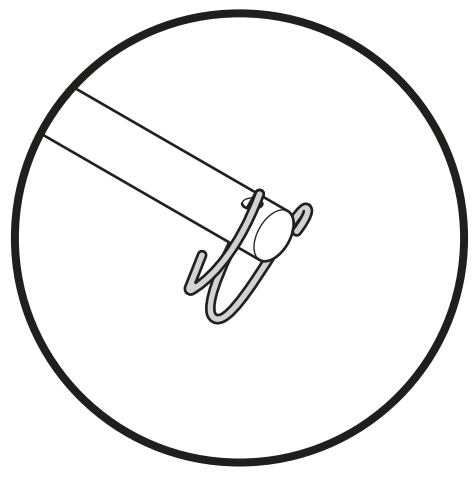
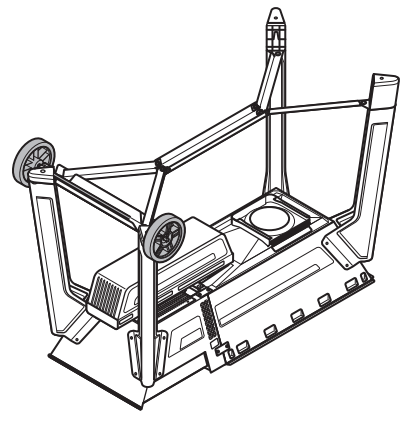
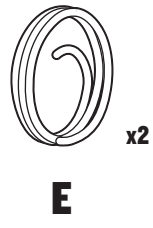

4 MONTER LES ROUES





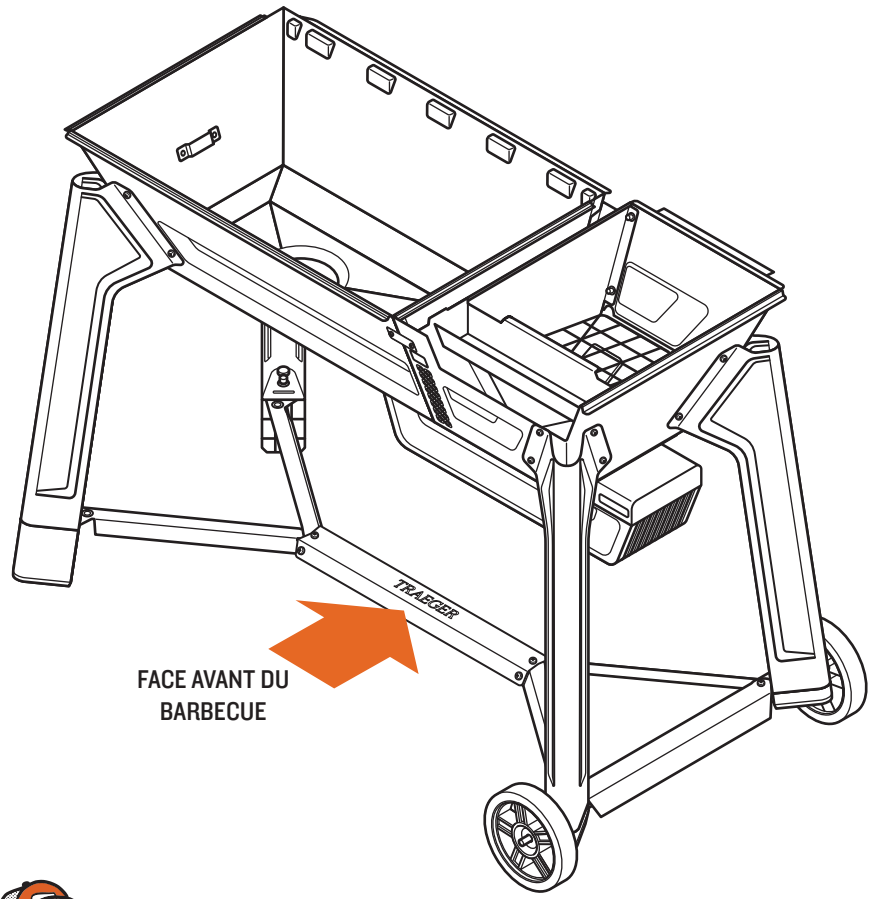
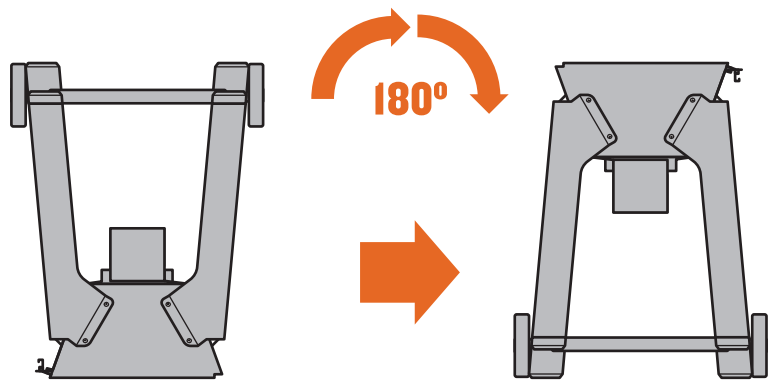
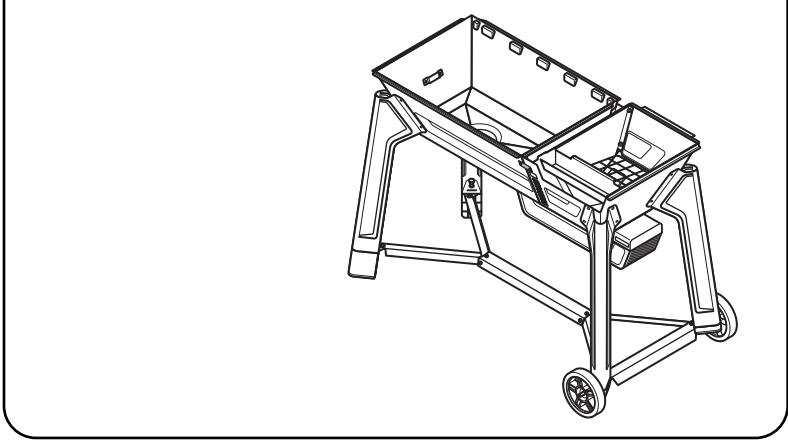

CONSEIL DE PRO : demandez à une deuxième personne de vous aider à soulever et à faire pivoter le barbecue.

5 RETOURNER LE BARBECUE

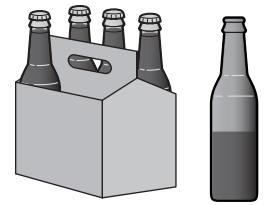

**BEAU TRAVAIL !
CHAPITRE 2 TERMINÉ !**



CHAPITRE 3

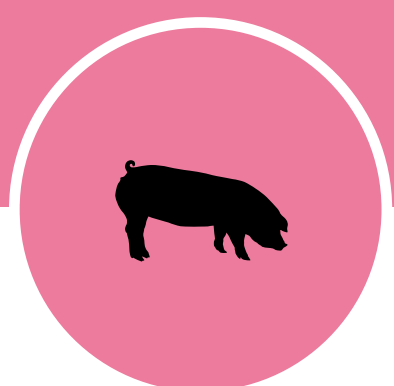
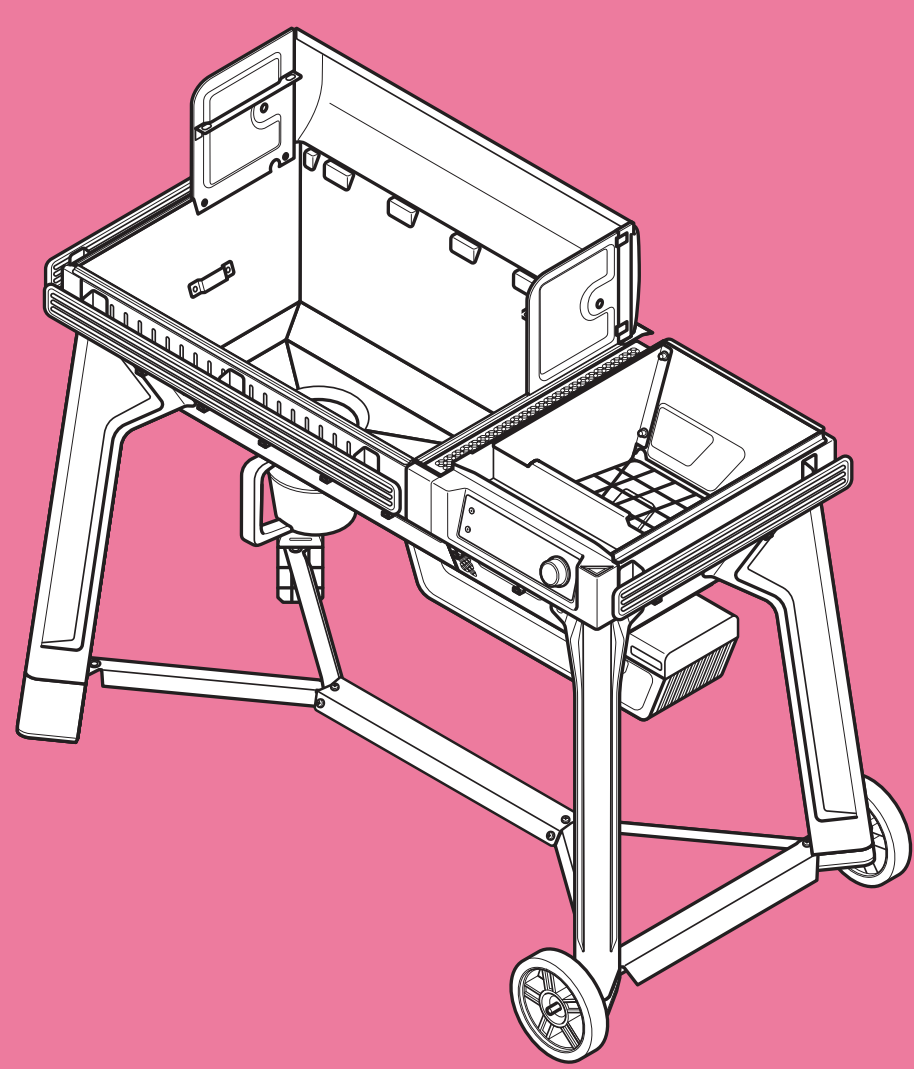



COMMANDES ET ÉTAGÈRES

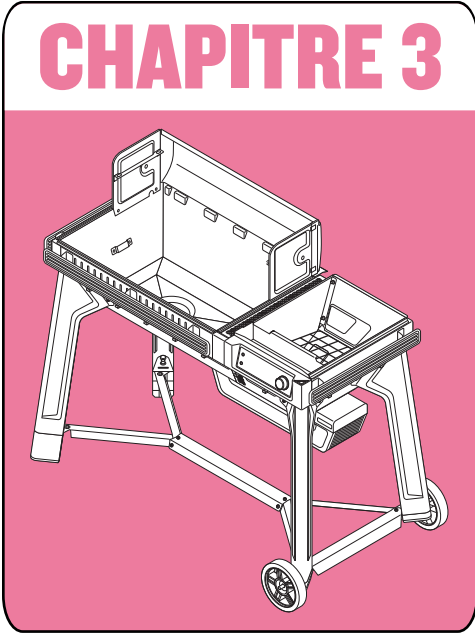

CHAPITRE 3

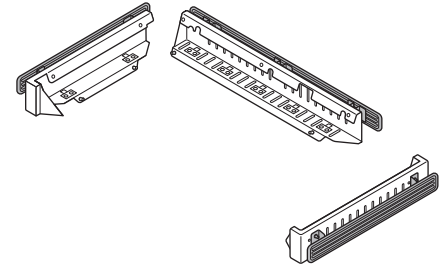
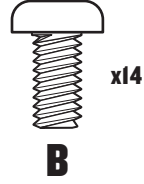
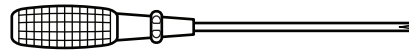

1 MONTER LES RAILS P.A.L.

CONSEIL DE PRO : serrez d'abord toutes les vis à la main, puis terminez le serrage avec un tournevis.



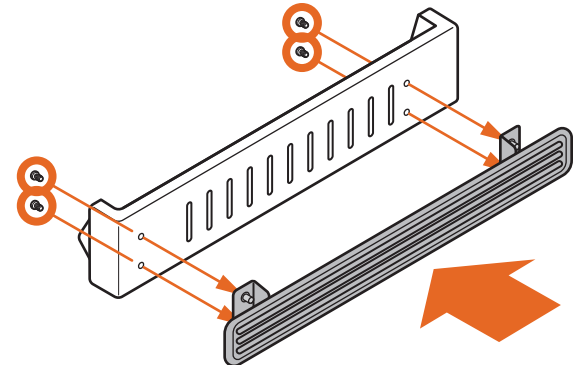
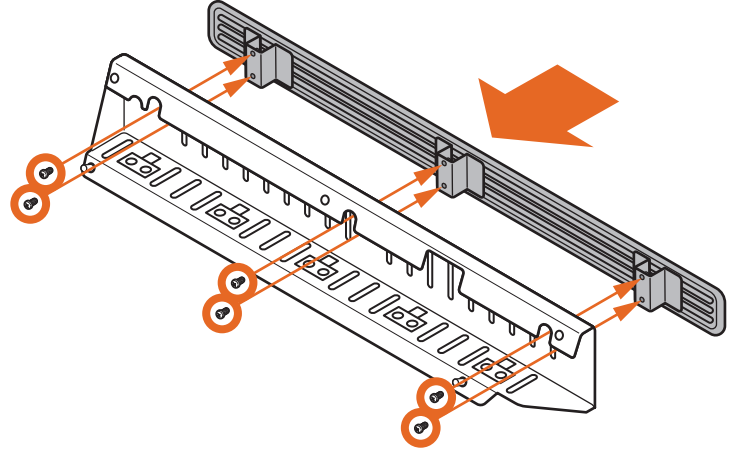
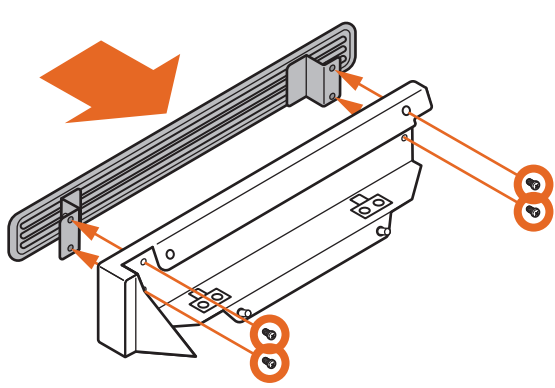



CONSEIL DE PRO : cette étape peut être délicate. Scannez notre QR code pour accéder aux animations vidéo de montage. Passez au chapitre 3, Étape 2 pour voir une vidéo.



CONSEIL DE PRO : Pour éviter que le matériel ne tombe dans le boîtier de la vis sans fin, posez ce manuel sur la grille.

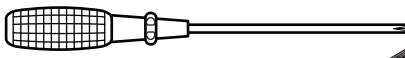
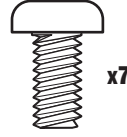
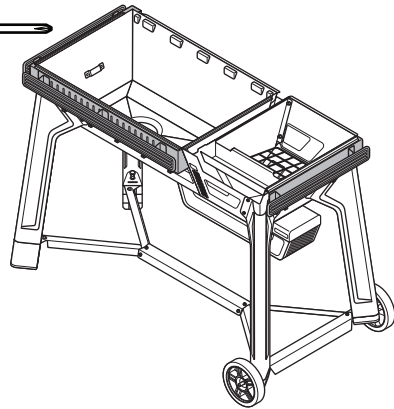

2A FIXER LA GARNITURE DU P.A.L.

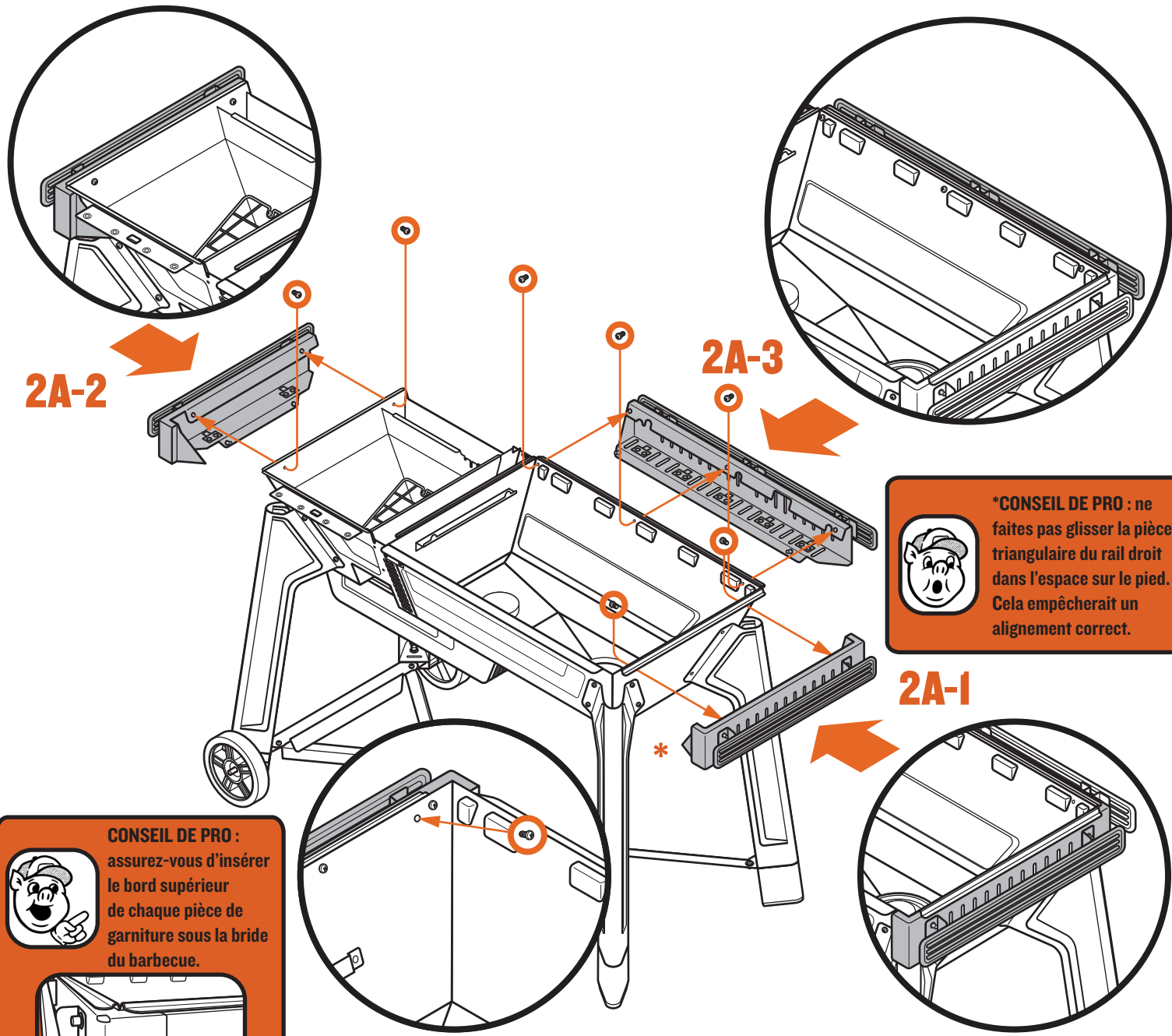
***CONSEIL DE PRO :** ne faites pas glisser la pièce triangulaire du rail droit dans l'espace sur le pied. Cela empêcherait un alignement correct.





CONSEIL DE PRO : assurez-vous d'insérer le bord supérieur de chaque pièce de garniture sous la bride du barbecue.







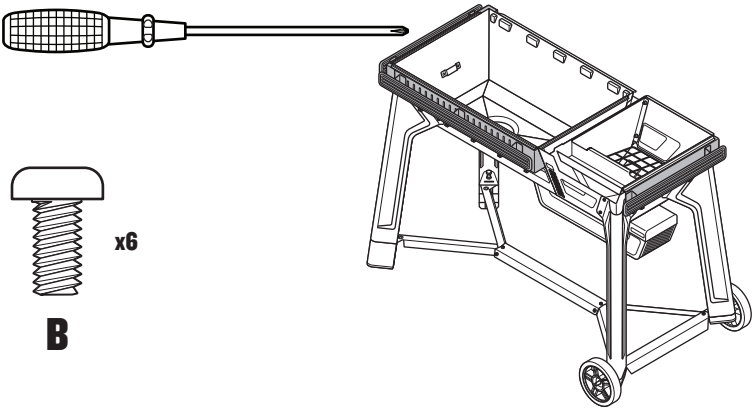

2B SÉCURISER LA GARNITURE P.A.L.

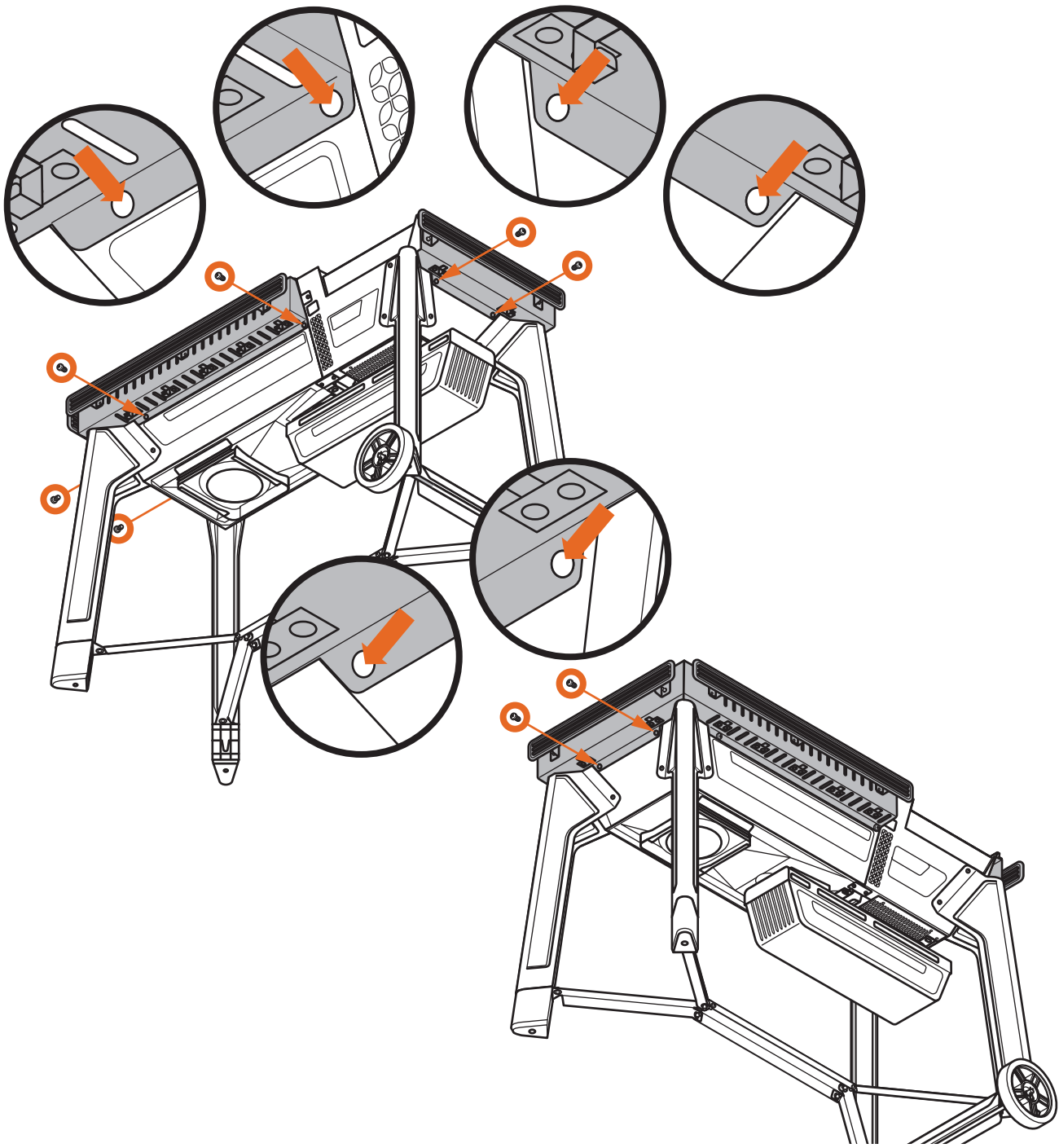

B x6



CONSEIL DE PRO : cette étape ne nécessite aucun matériel.

3 MONTER LE DOSSERET

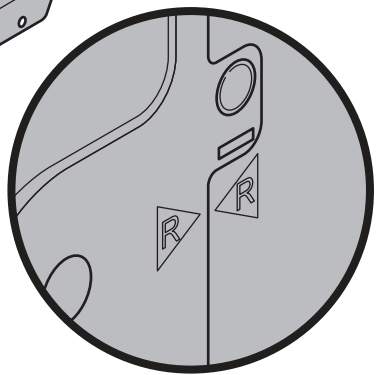
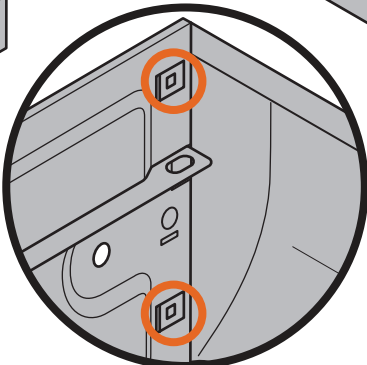
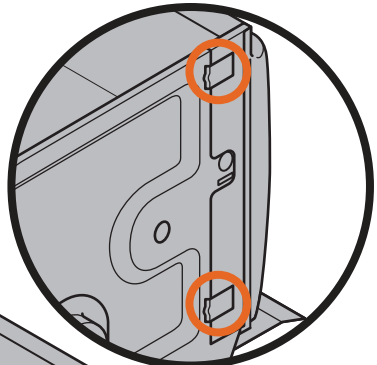
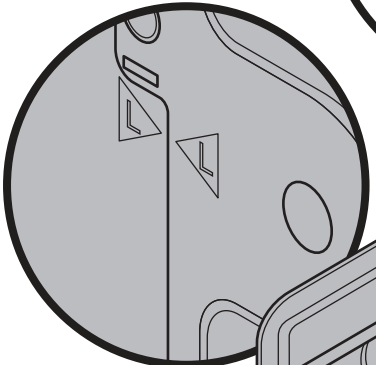
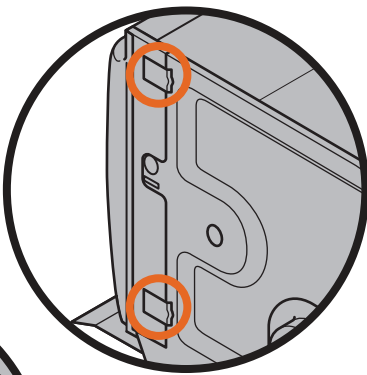
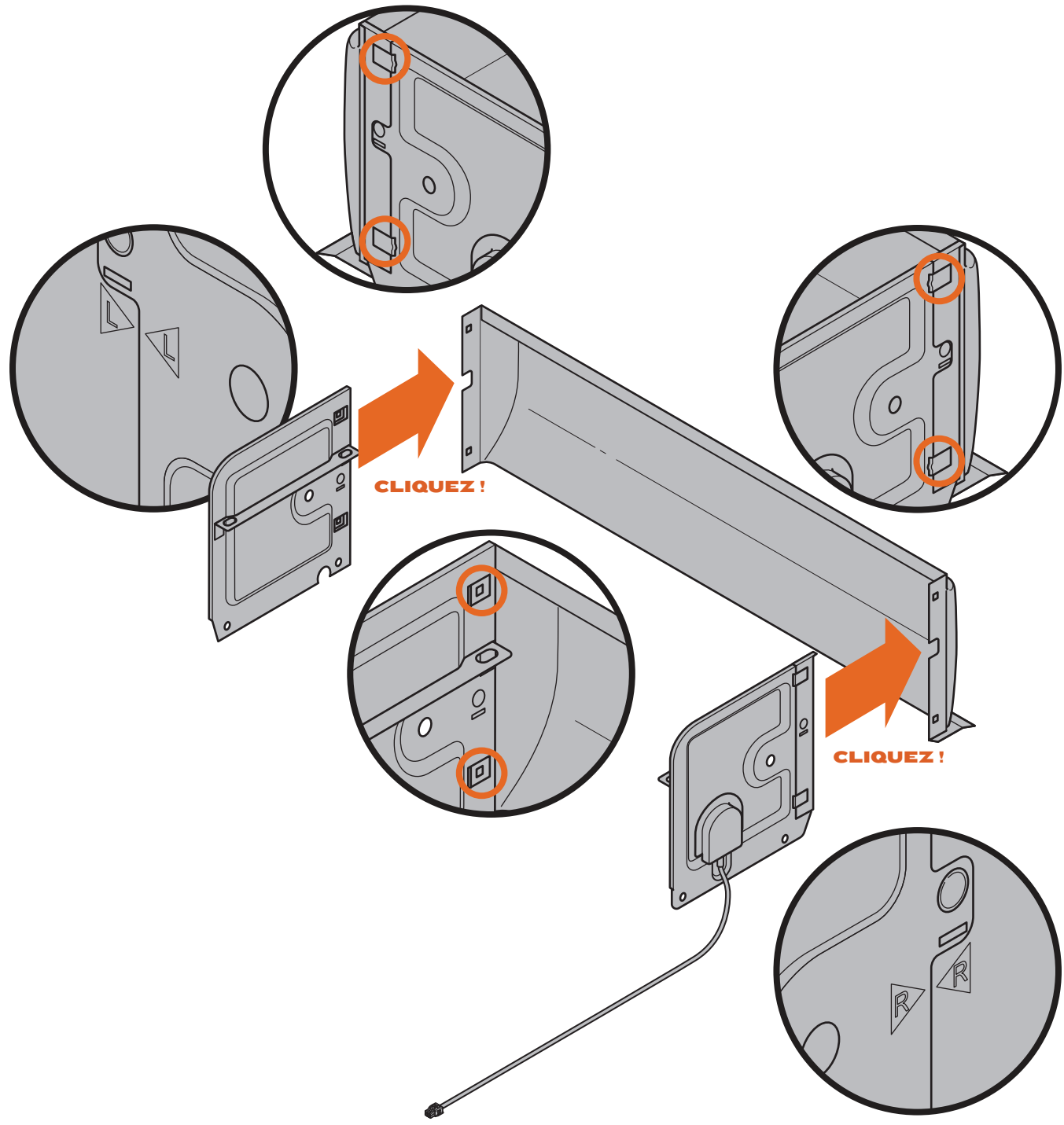
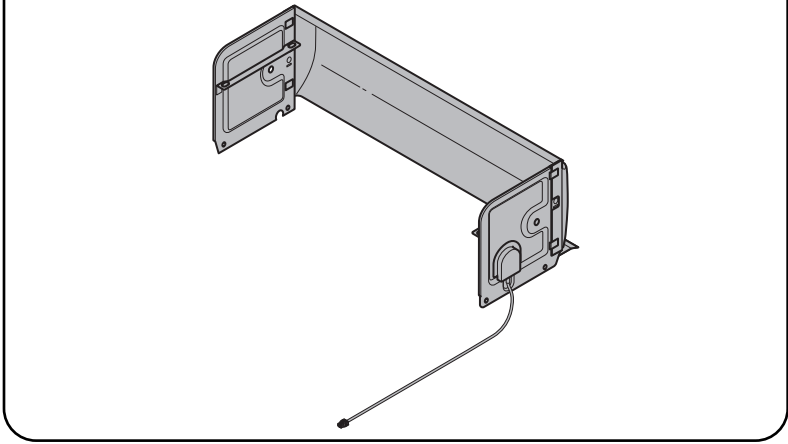

CONSEIL DE PRO : ne pincez pas le câble entre le dossieret et le corps du barbecue ! Faites également glisser le câble à travers les ouvertures avec précaution pour éviter tout dommage !

4 ACHEMINER LE CÂBLAGE DU DOSSERET

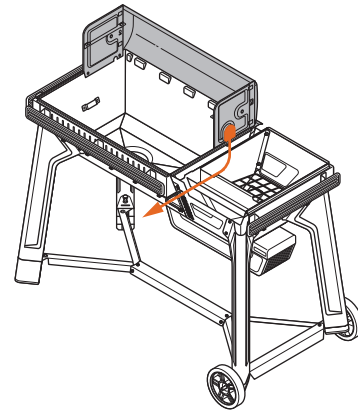

4A

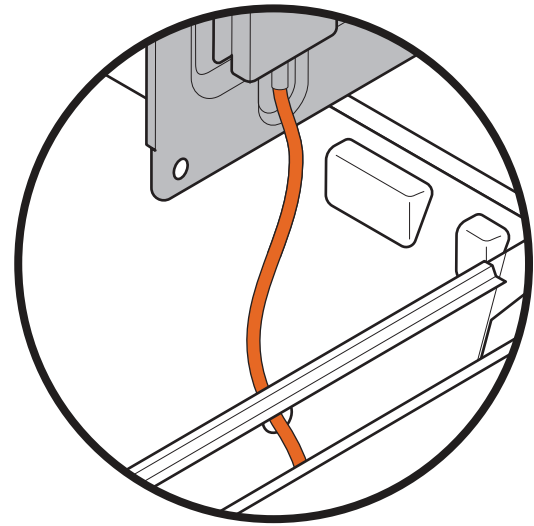
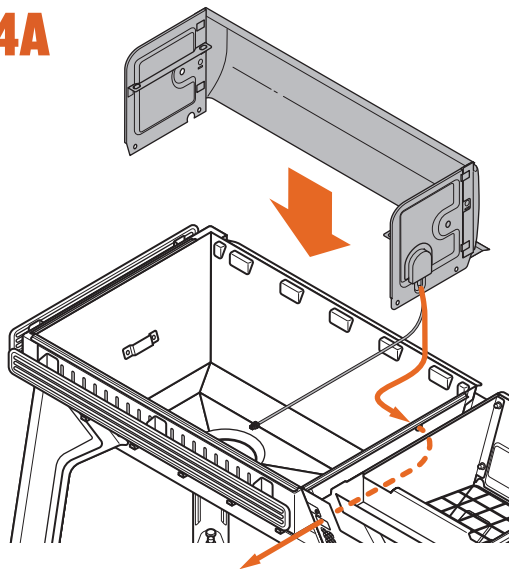

4B

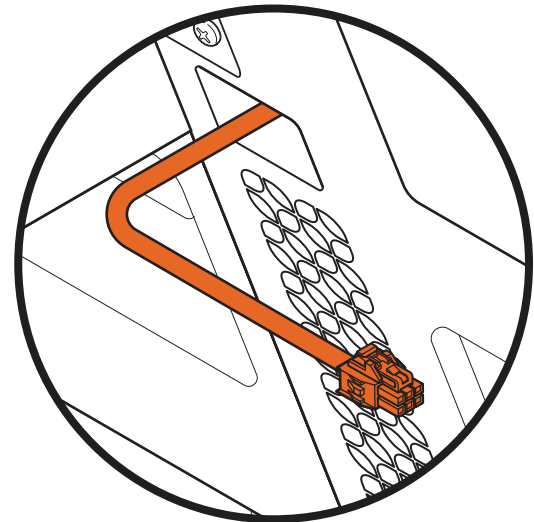
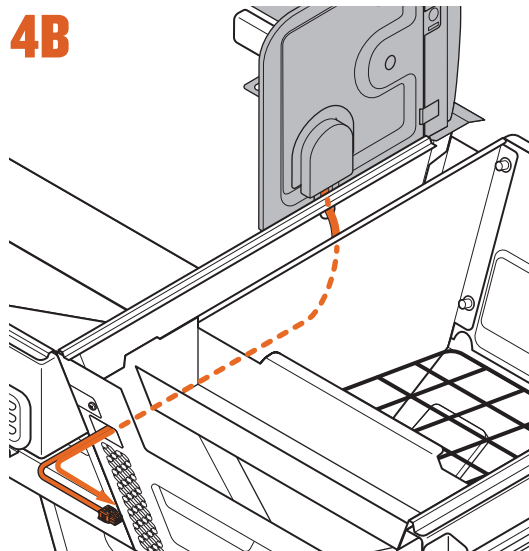



5 FIXER LE DOSSERET

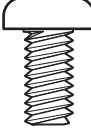
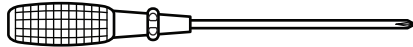

B x4

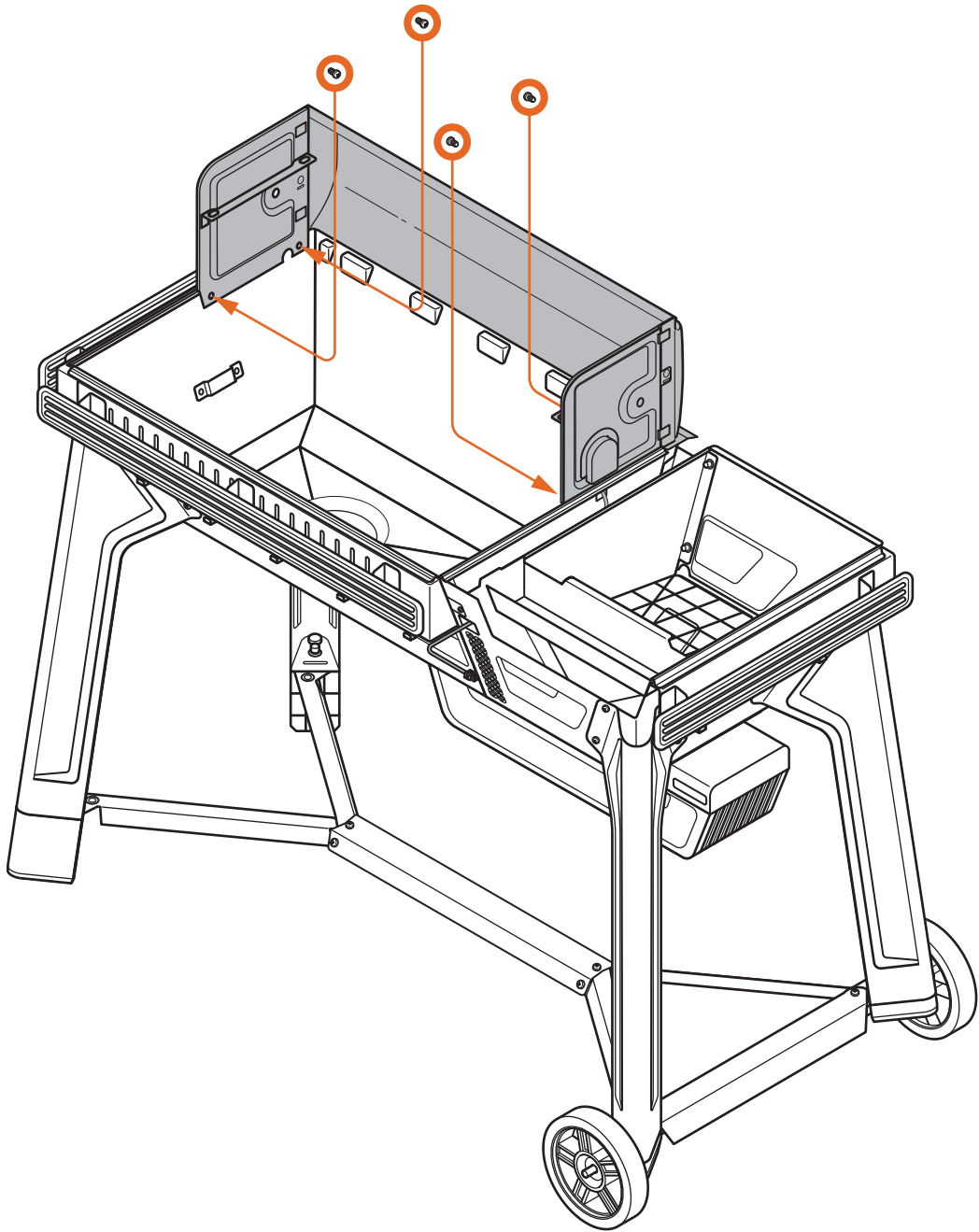
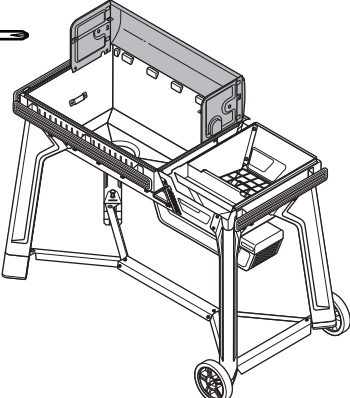



6 INSTALLER LES CROCHETS ARRIÈRE

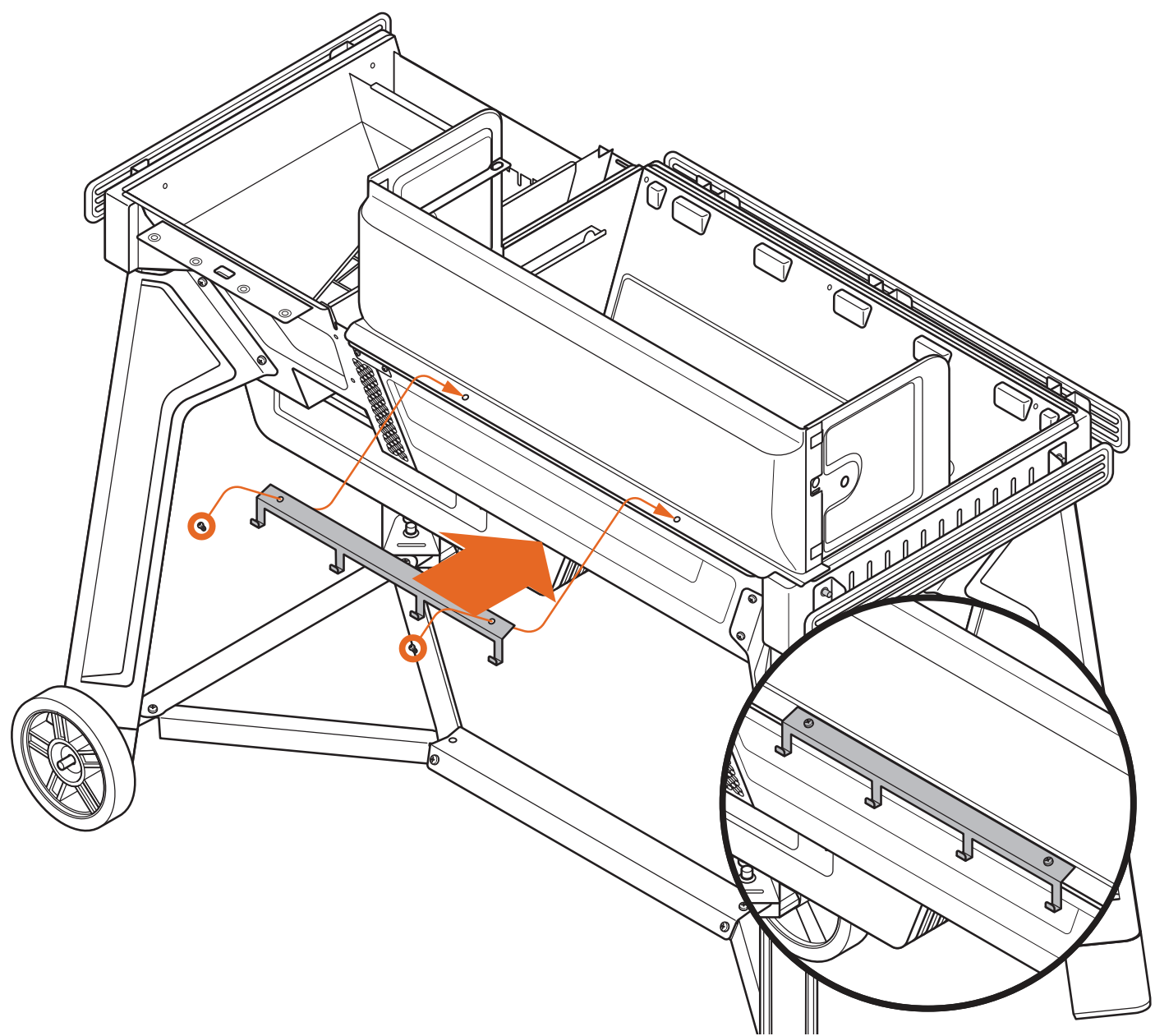
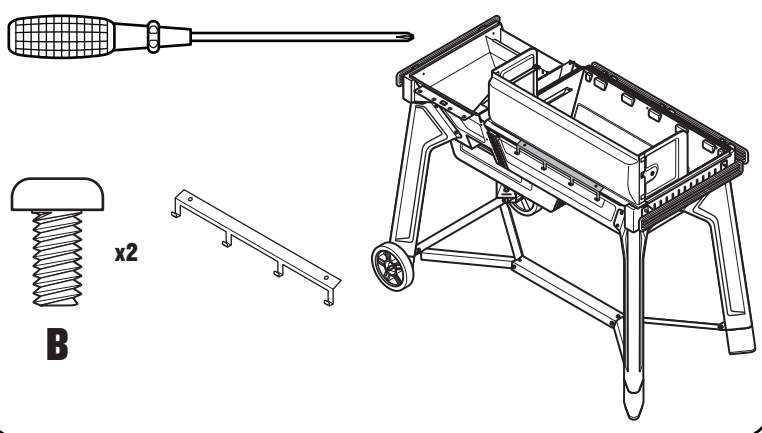



7 CONNECTER LE PANNEAU DE COMMANDE

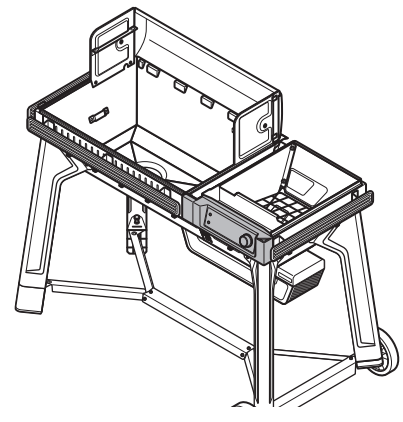
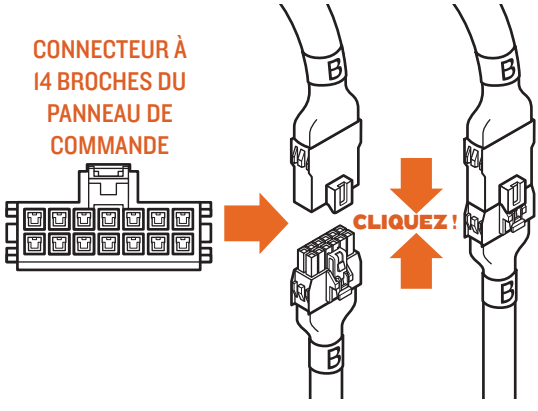

CONSEIL DE PRO : pour une connexion plus facile, posez le panneau de commande sur le dos, sur le bord de la trémie.

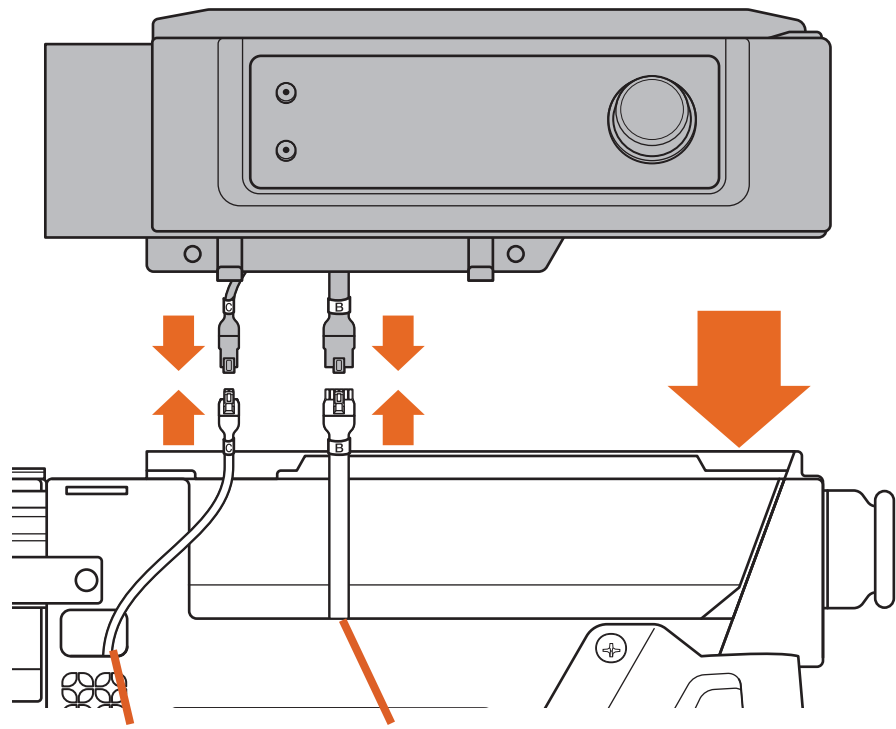
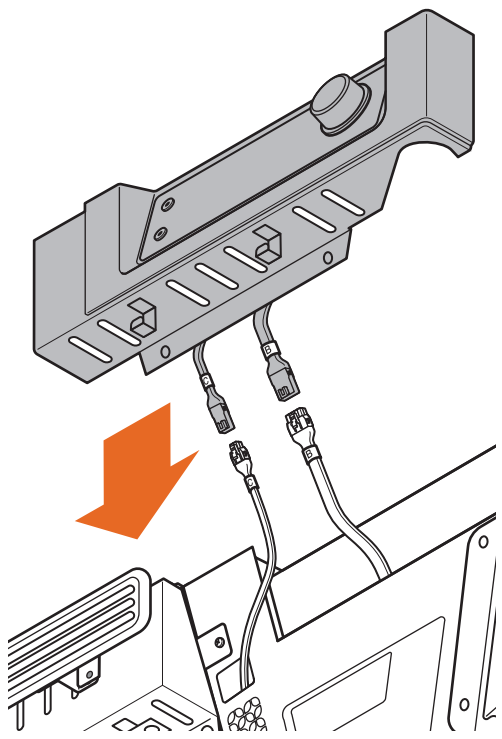

CONSEIL DE PRO : après la connexion, replacez les câbles dans le barbecue pour éviter de les pincer.

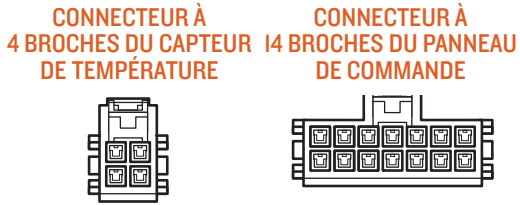

CONSEIL DE PRO : pour connecter plus facilement le connecteur B, coupez le collier de serrage qui le maintient au barbecue.



 **CONSEIL DE PRO :** installez le panneau de commande sur la bride dans la trémie.

8A FIXER LE PANNEAU DE COMMANDE

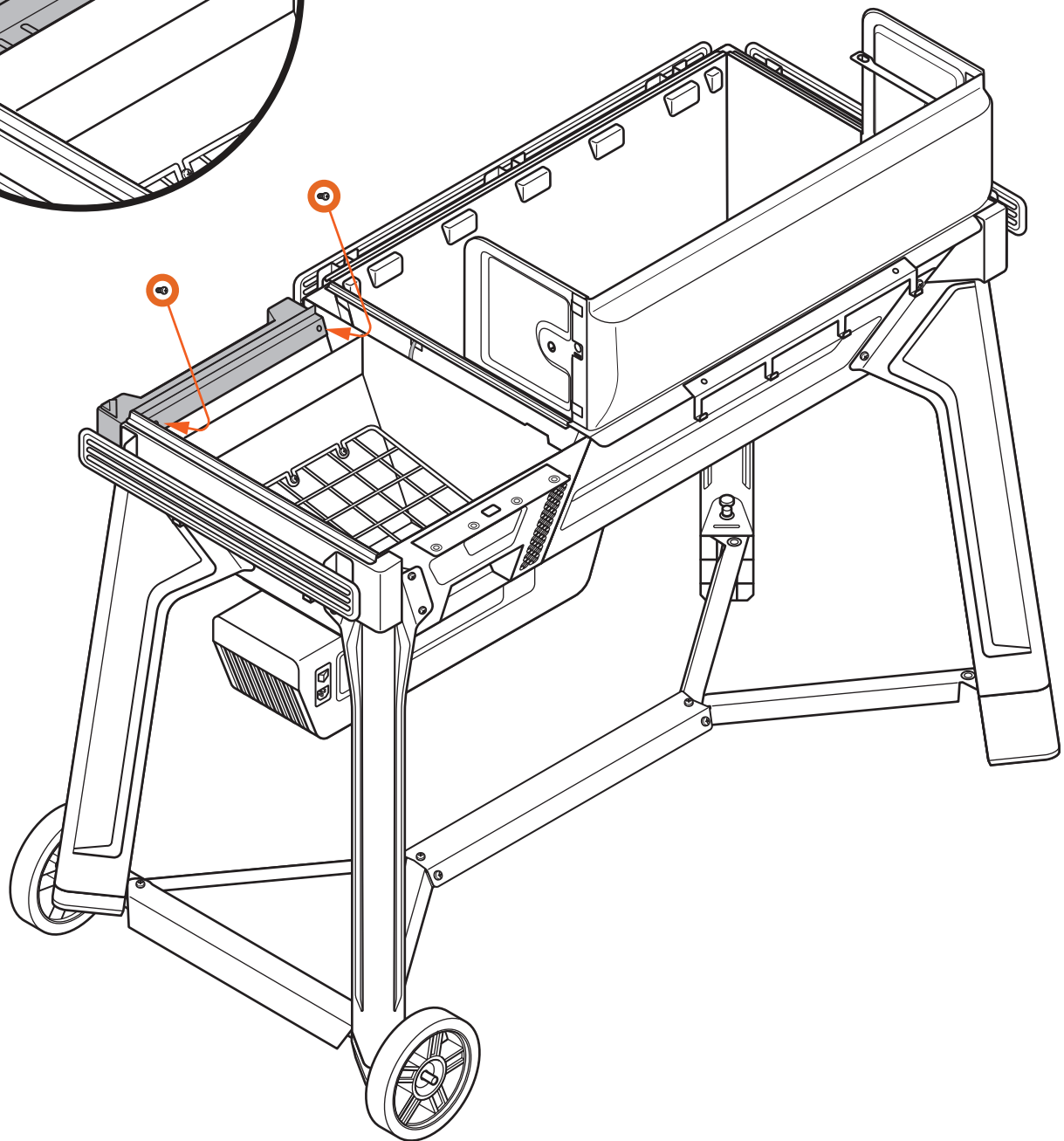
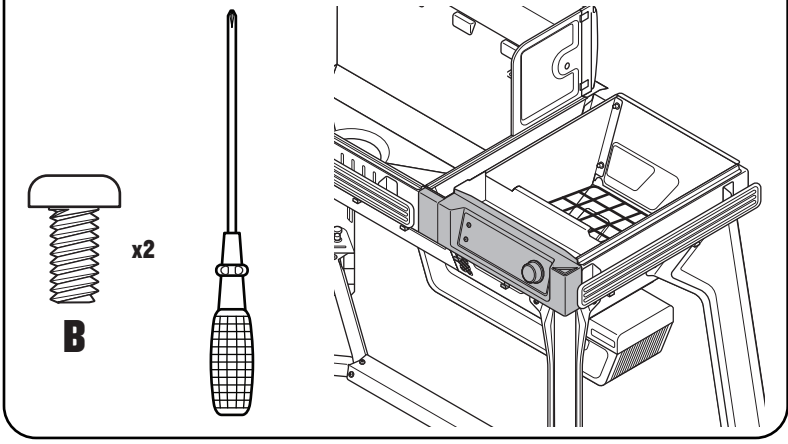
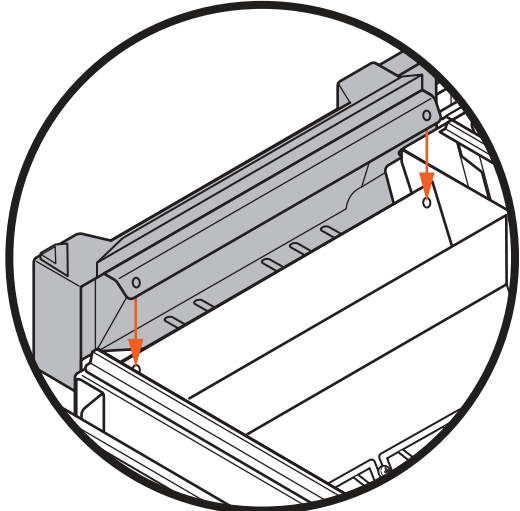



8B FIXER LE PANNEAU DE COMMANDE

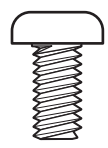

x2

B

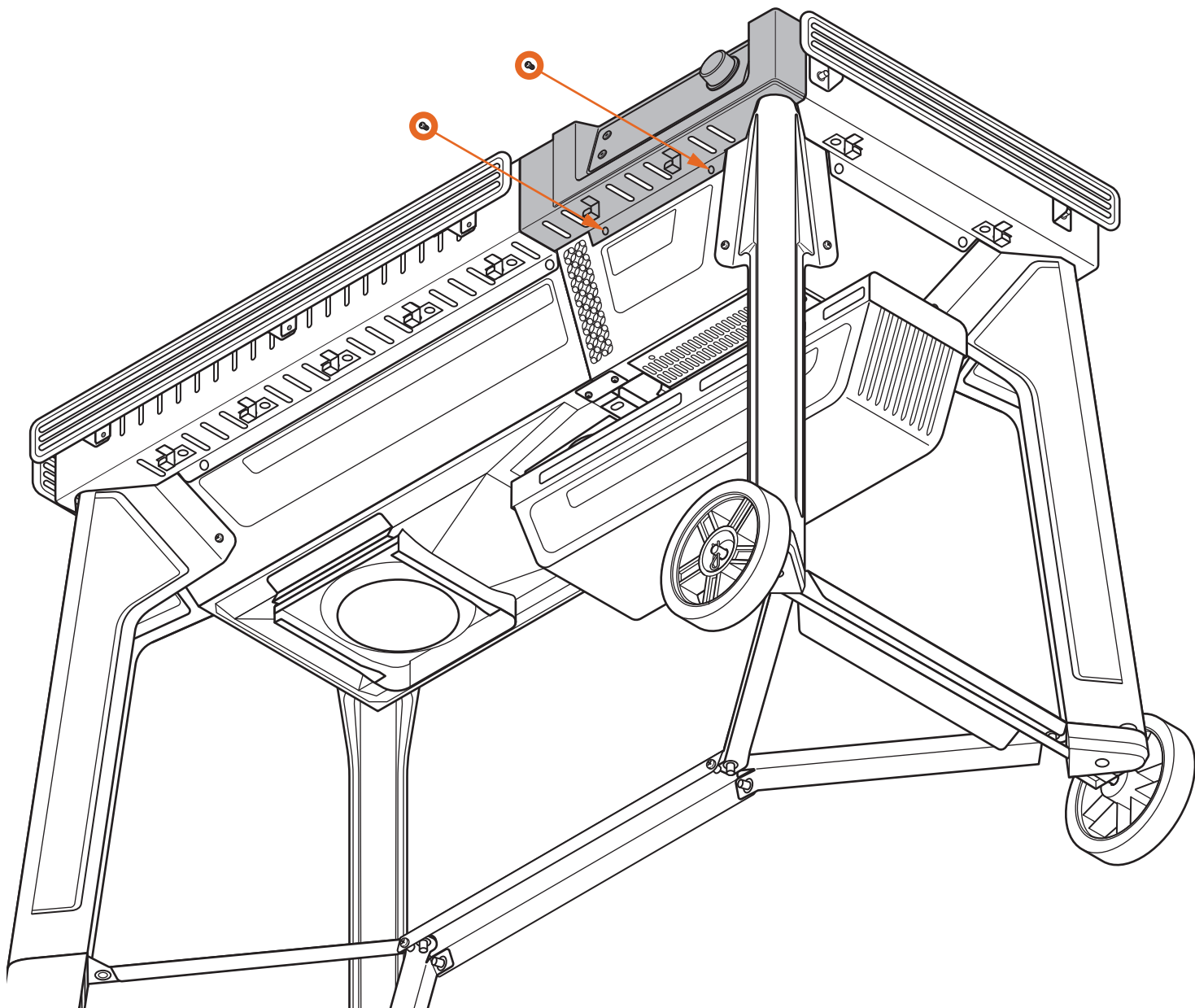
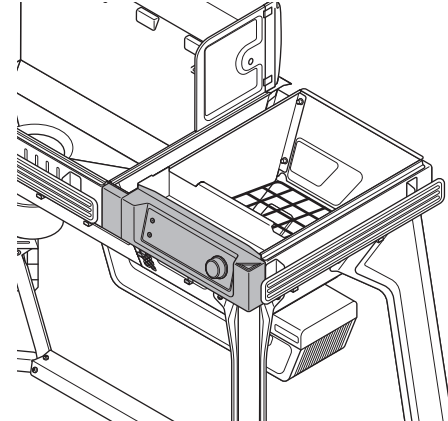
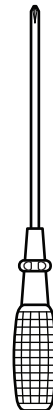



9 FIXER LA PLAQUE DE VENTILATION

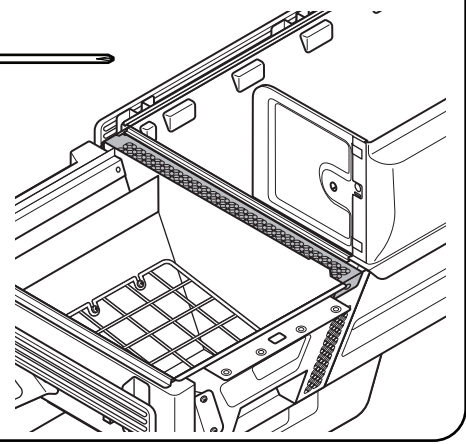
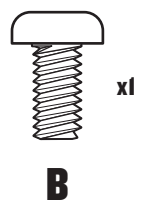
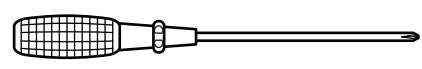

9A

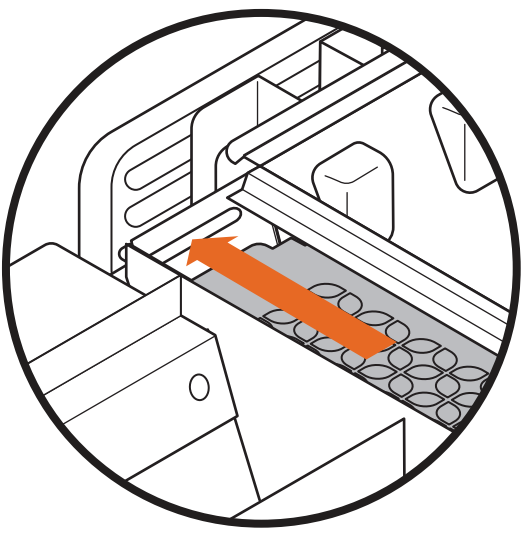

9B

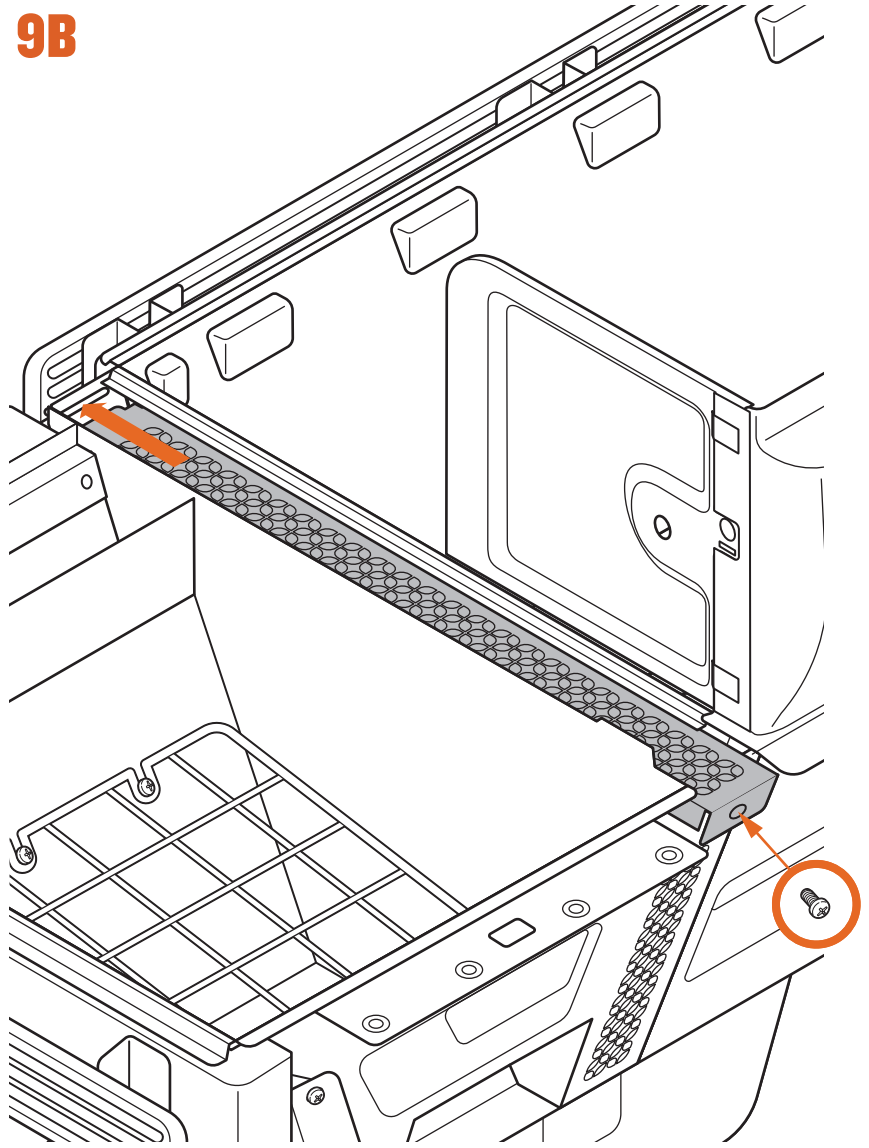

**BEAU TRAVAIL !
CHAPITRE 3 TERMINÉ !**

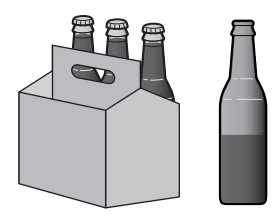

CHAPITRE 4

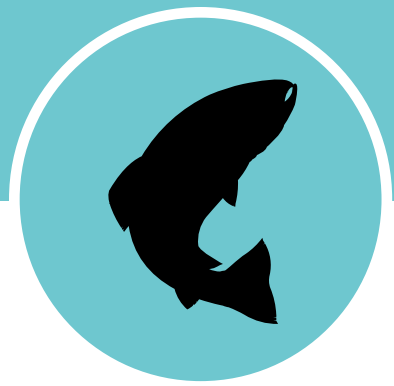
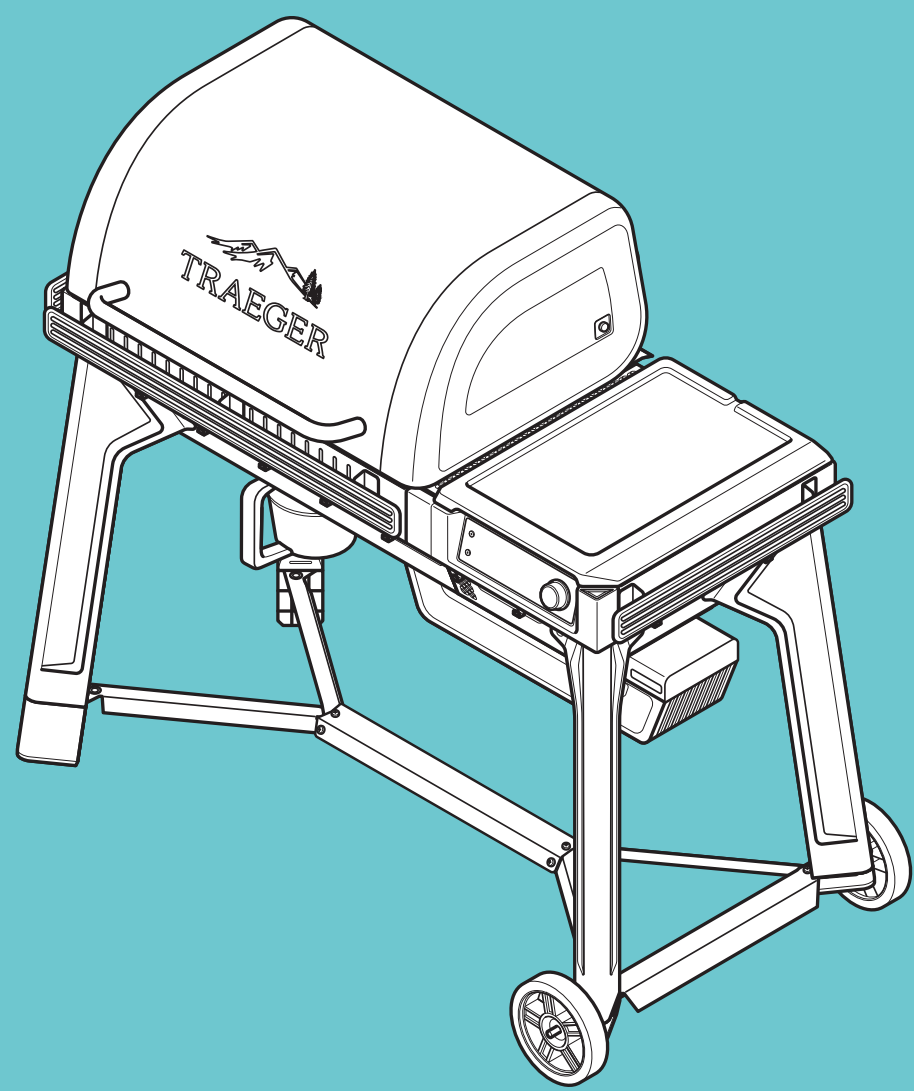

COUVERCLE ET COMPOSANTS INTERNES DU BARBECUE

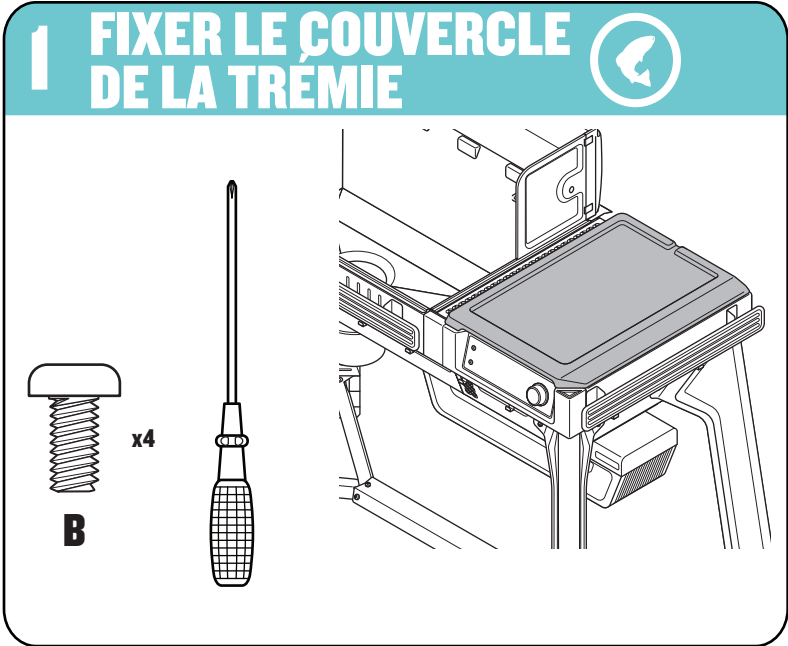

CONSEIL DE PRO : serrez d'abord toutes les vis à la main, puis terminez le serrage avec un tournevis.

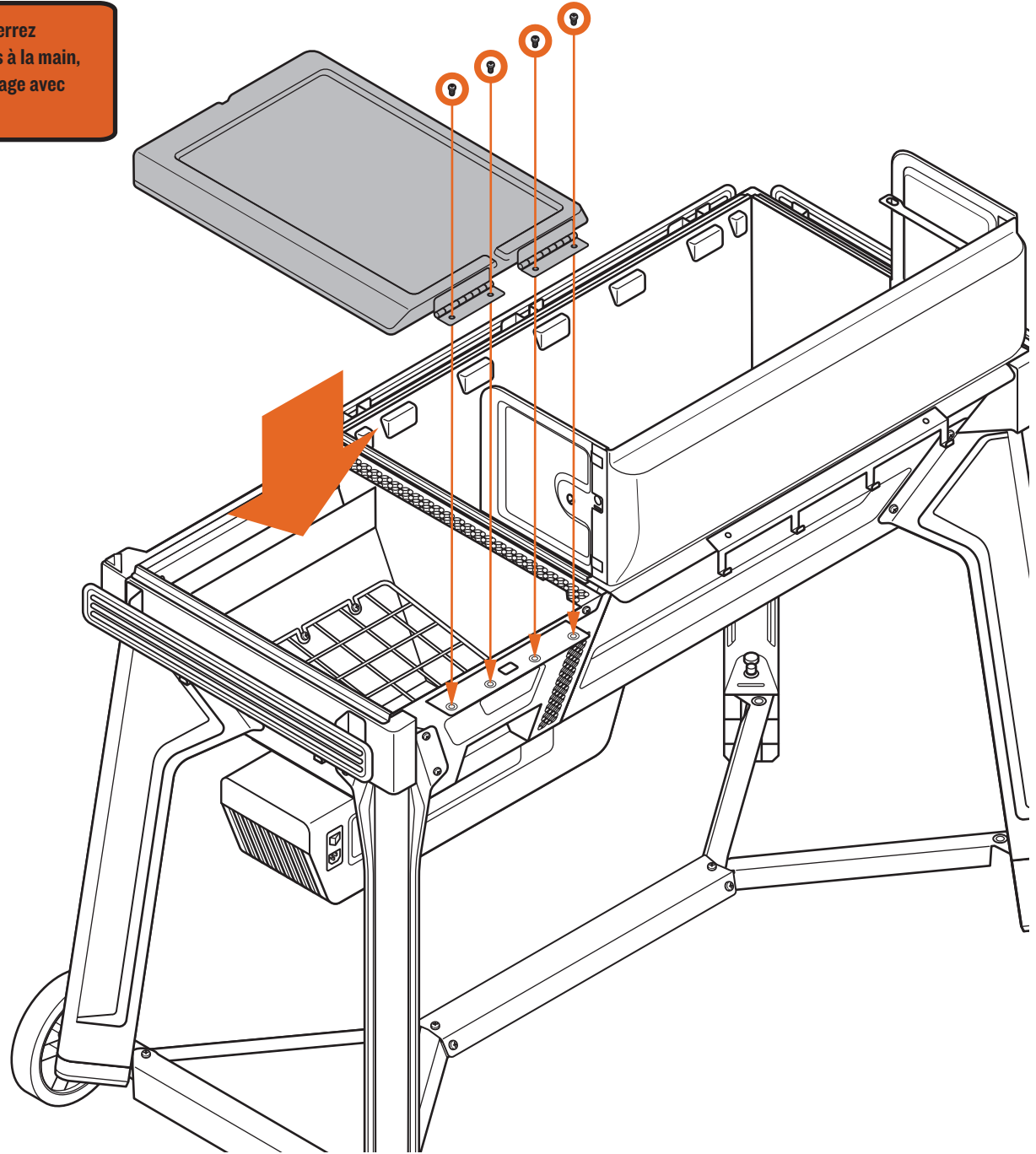



2A INSTALLER LA GOULOTTE, LE BOUCLIER ET LE DÉFLECTEUR

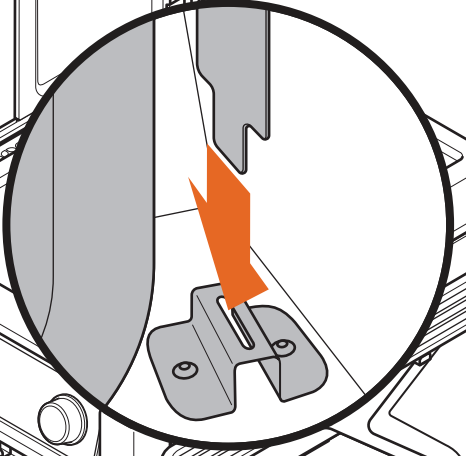
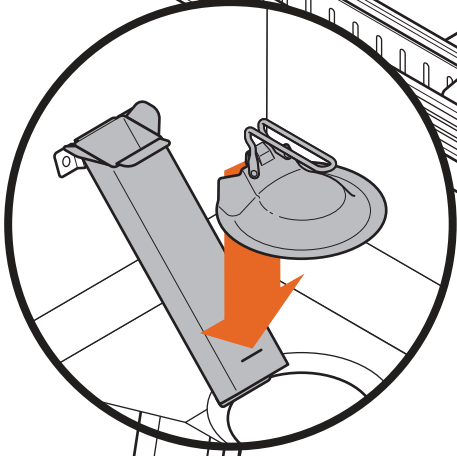
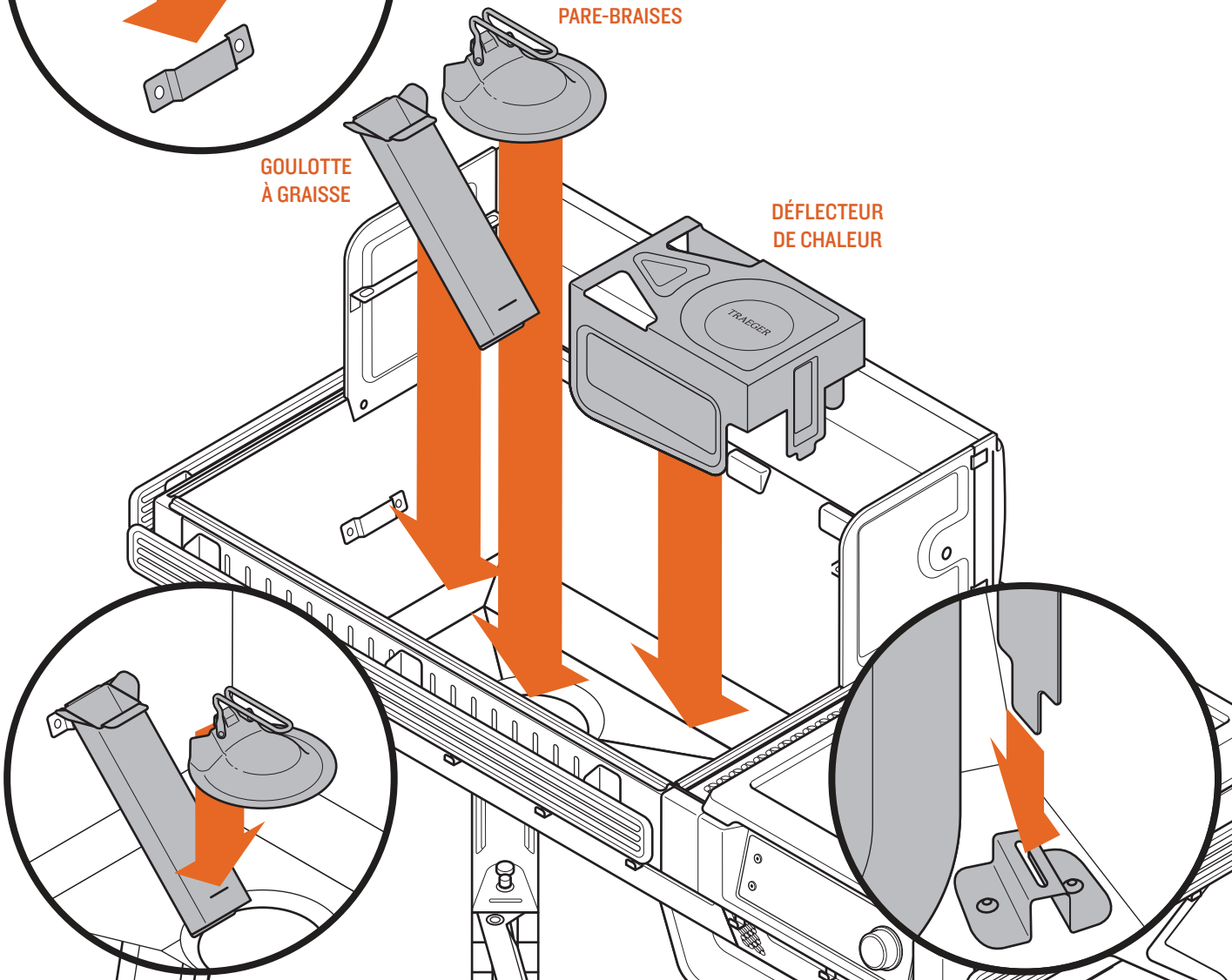
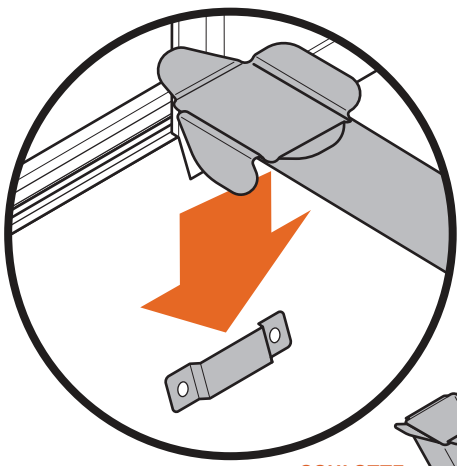
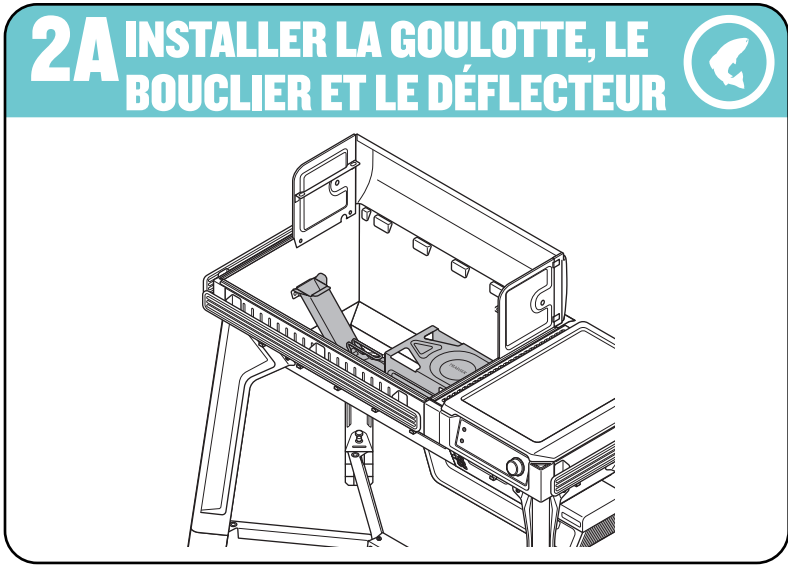
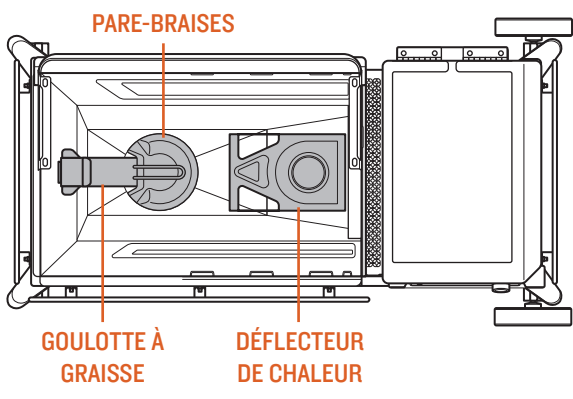



2B INSTALLER LE PLATEAU D'EGOUTTEMENT

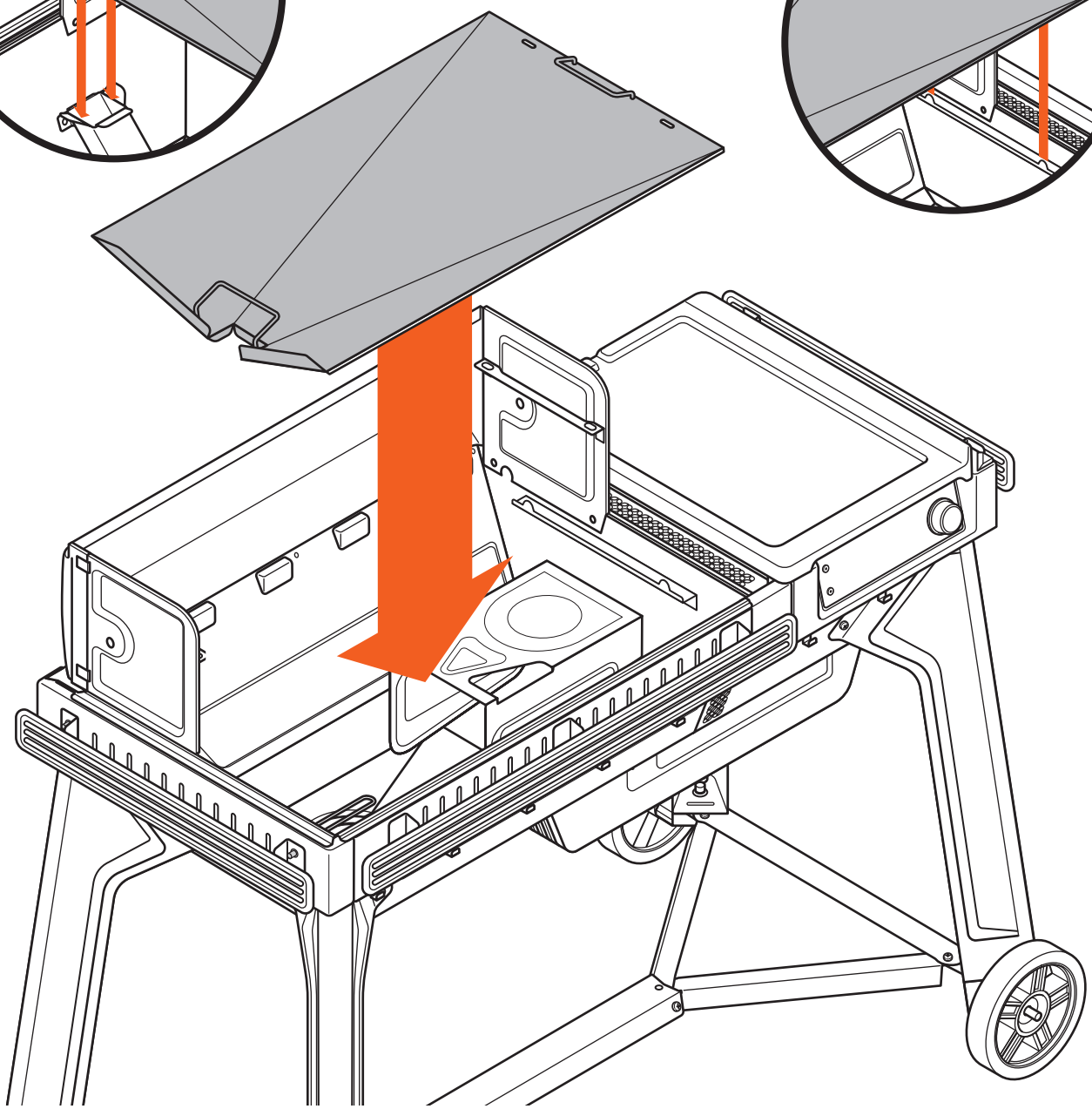
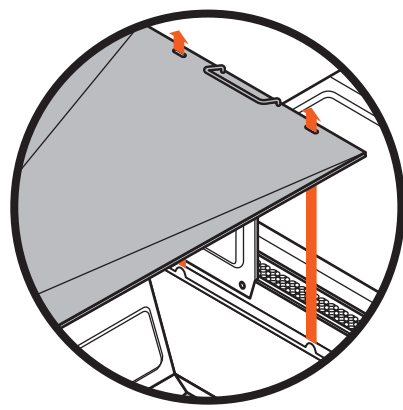
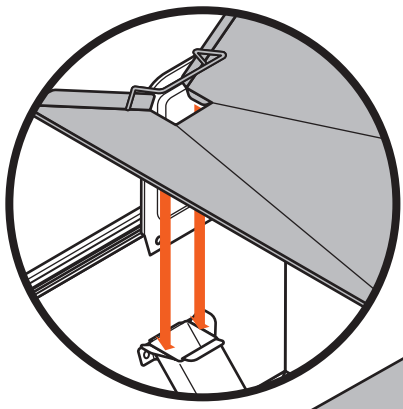
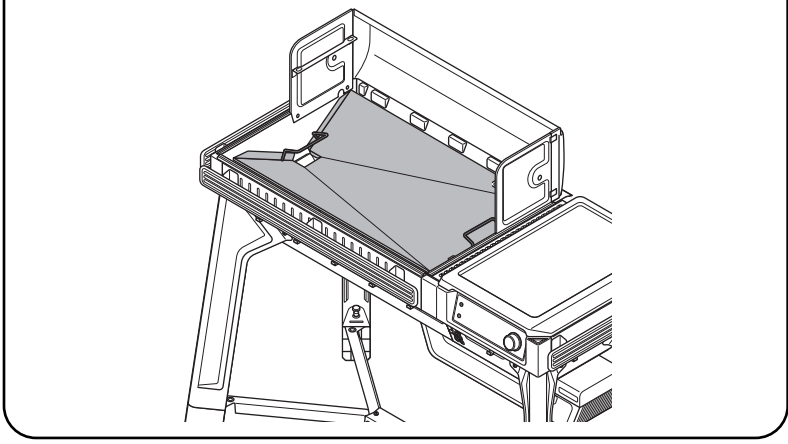



3A FIXER LA POIGNÉE DU COUVERCLE

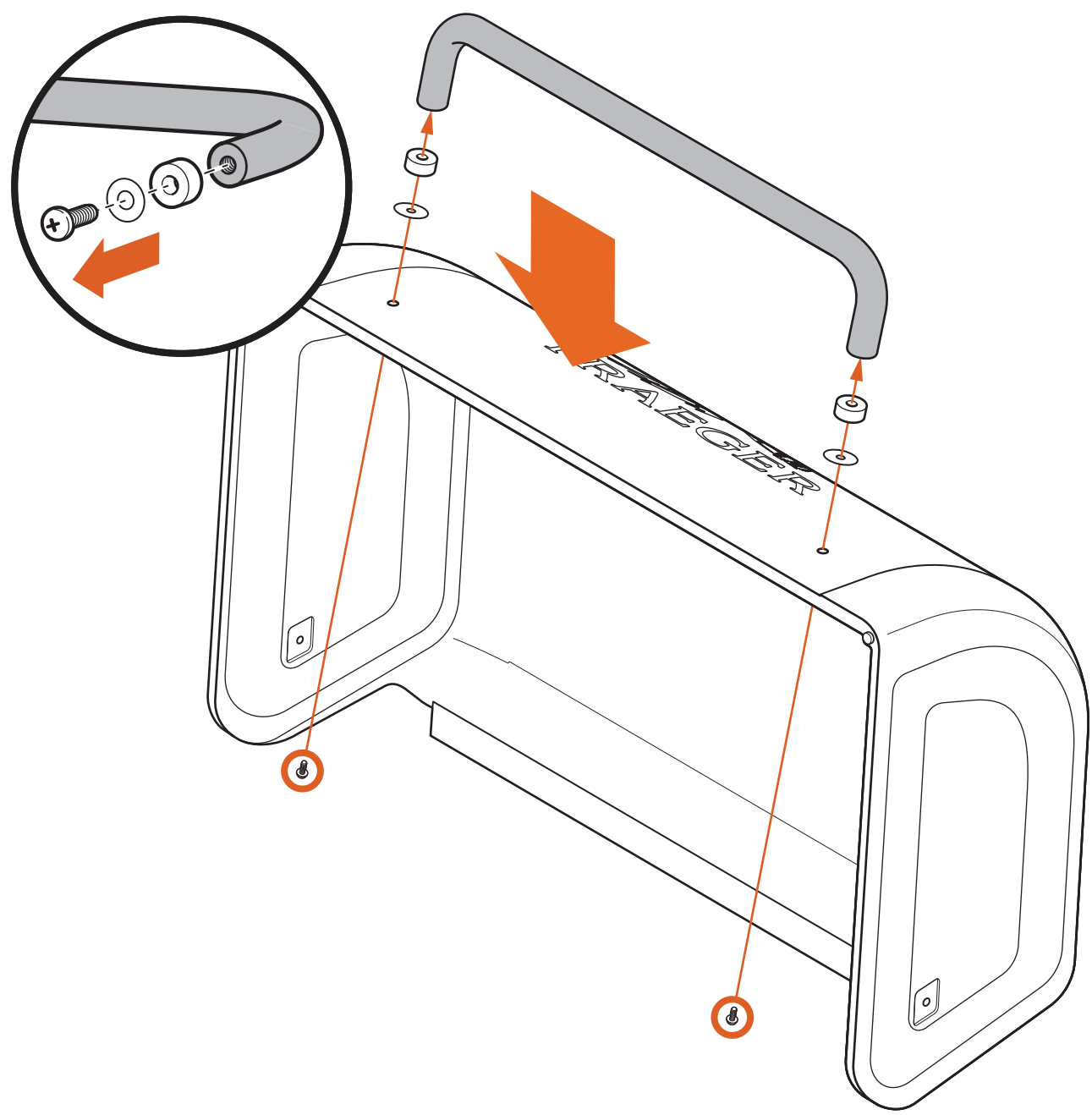
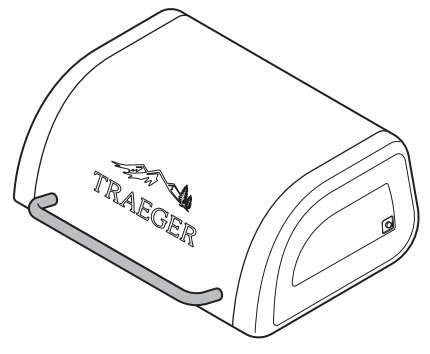
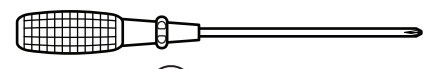



 **CONSEIL DE PRO :** utilisez deux personnes pour fixer le couvercle.

3B FIXER LE COUVERCLE

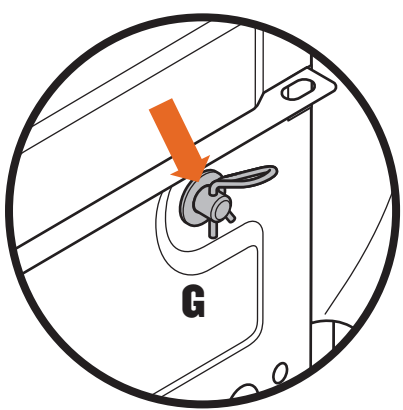
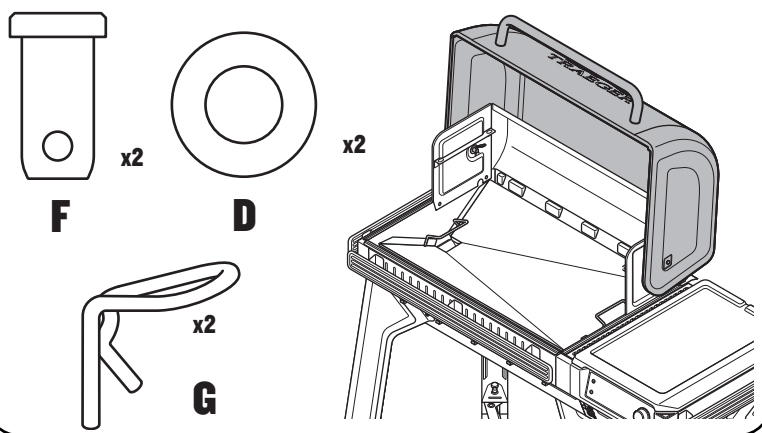

 **CONSEIL DE PRO :** fixez les goupilles à épaulement F avec le couvercle fermé, puis ouvrez le couvercle pour installer G et D.

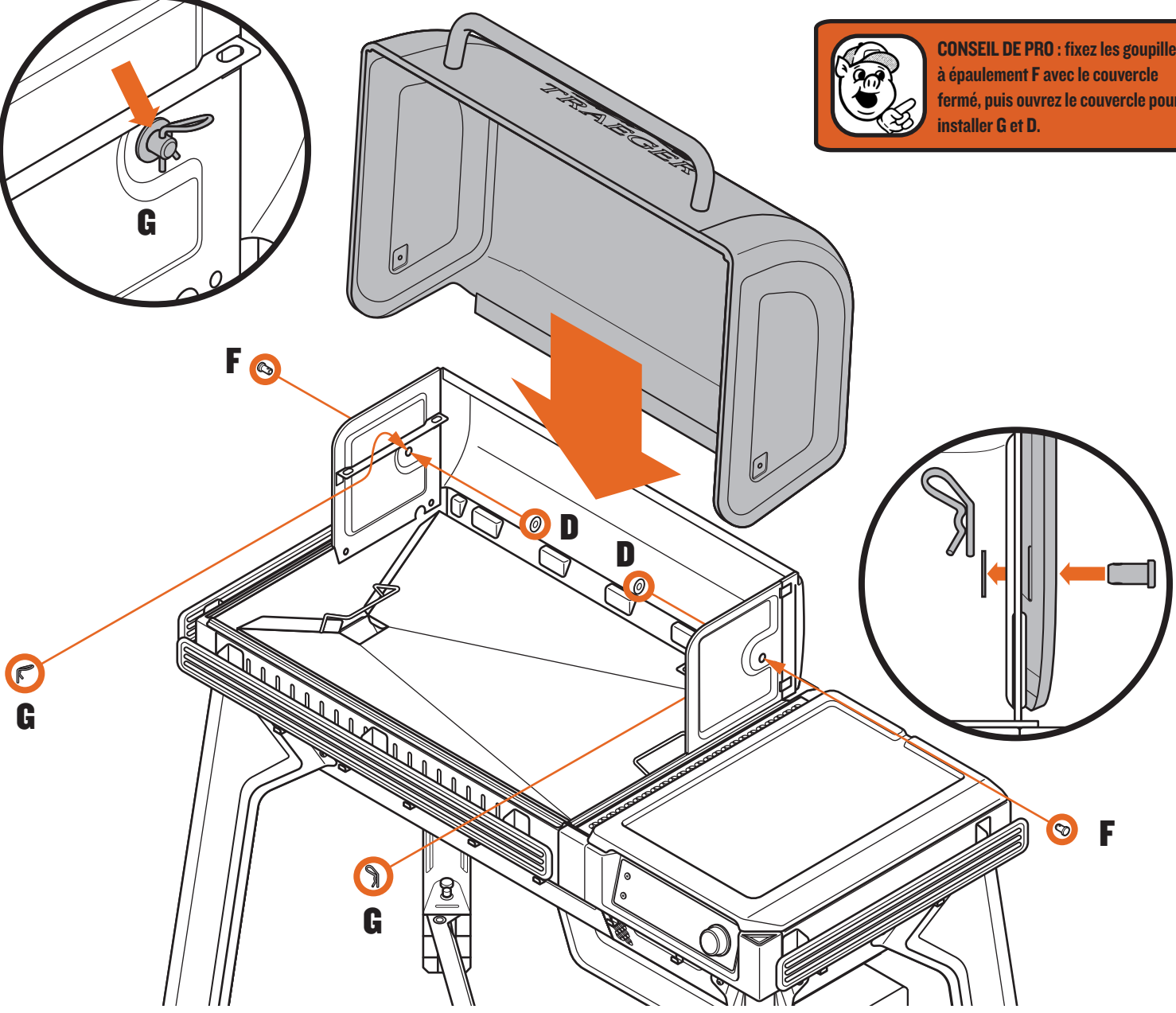



4 INSTALLER LES GRILLES

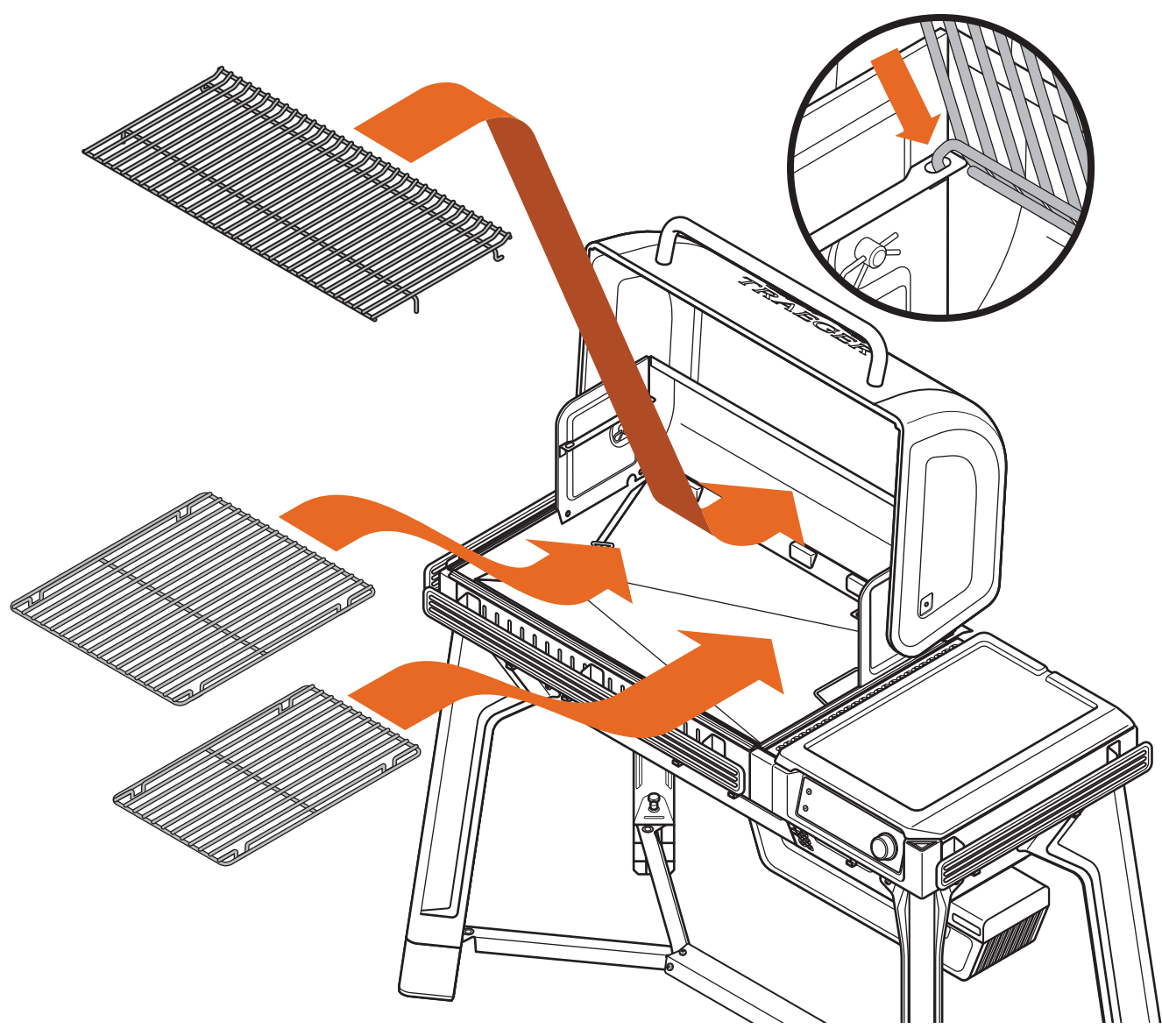
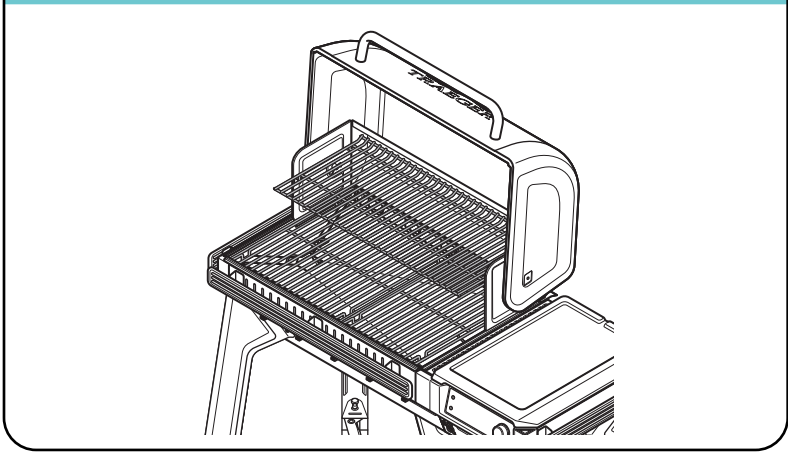



5 INSTALLER LE SEAU À GRAISSE ET À CENDRES

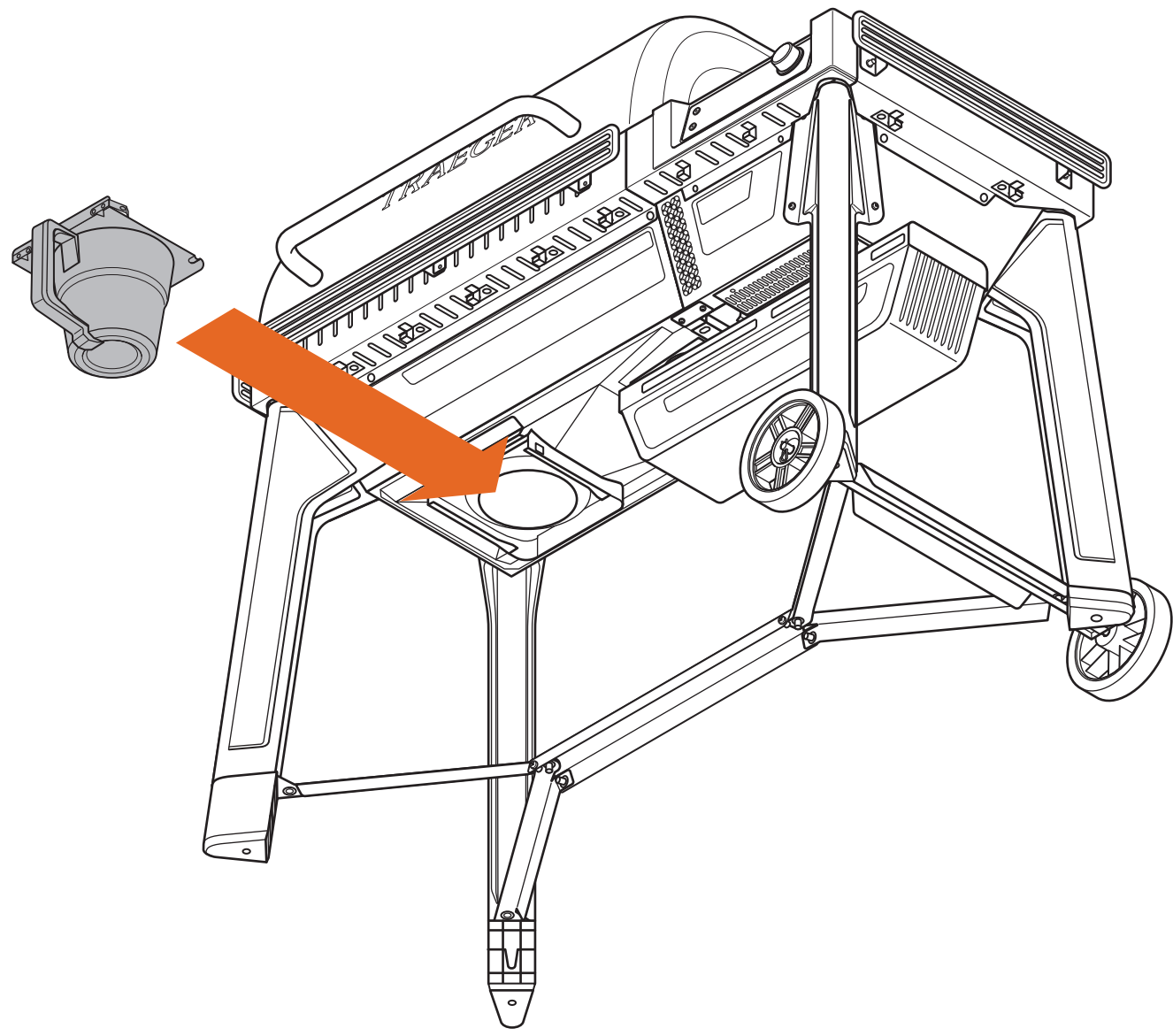
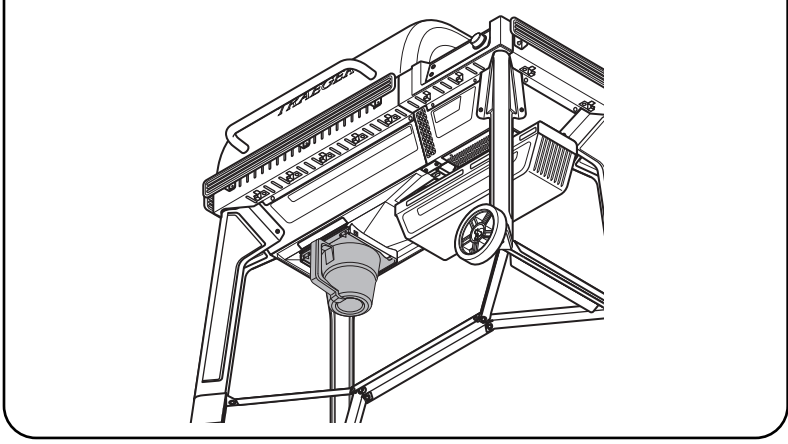



6 BRANCHER LE CORDON D'ALIMENTATION

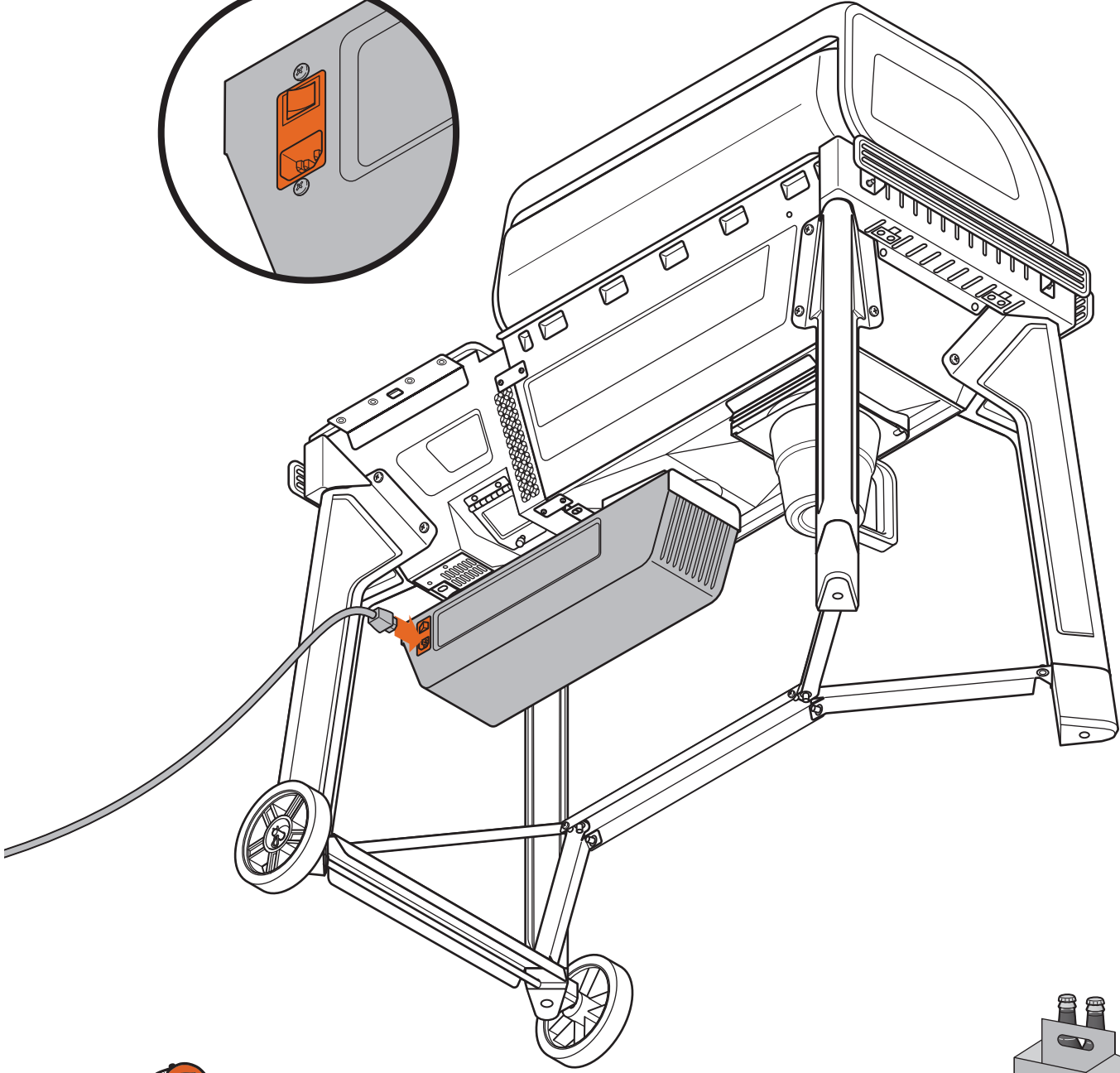
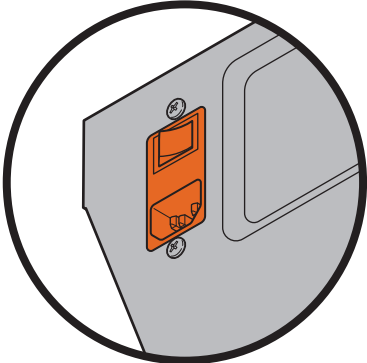
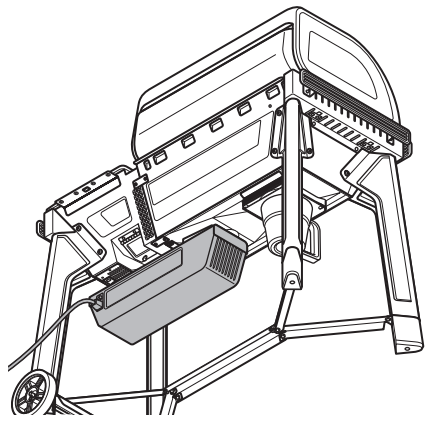

**BEAU TRAVAIL !
CHAPITRE 4 TERMINÉ !**

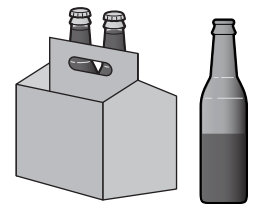

RANGEMENT DES PIÈCES ET ACCESSOIRES

Sonde filaire et cordon d'alimentation

POUR RANGER :

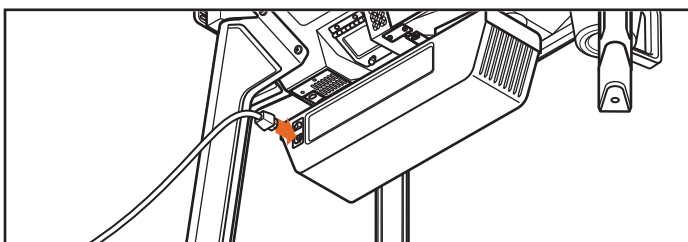
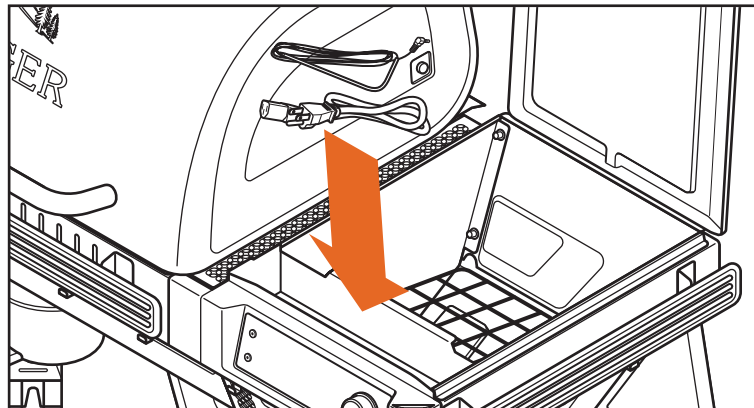
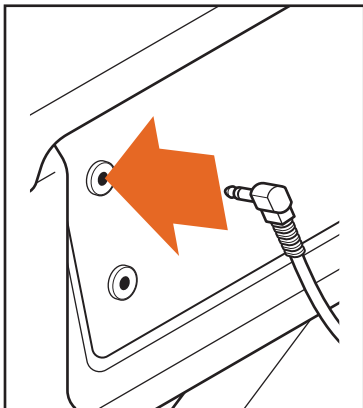

Grilles de barbecue, plateau d'égouttement, goulotte à graisse et pare-braises

POUR RANGER PENDANT LE NETTOYAGE :

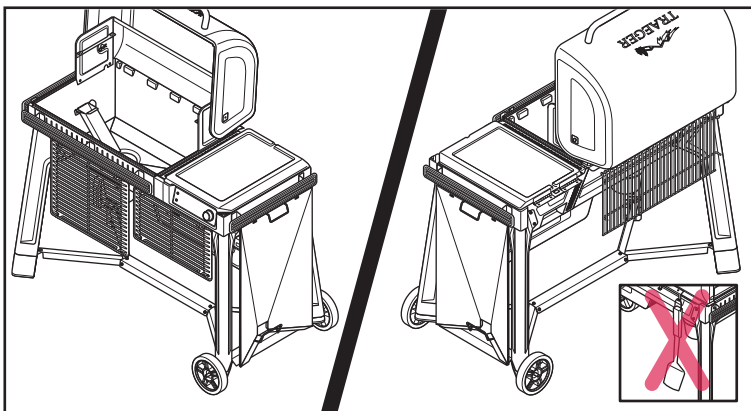
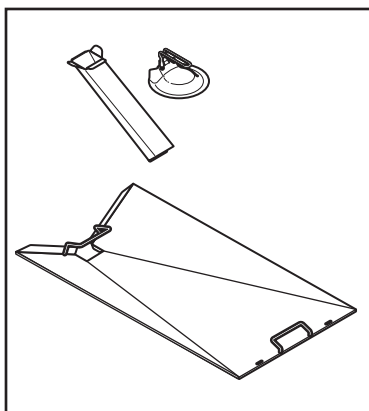
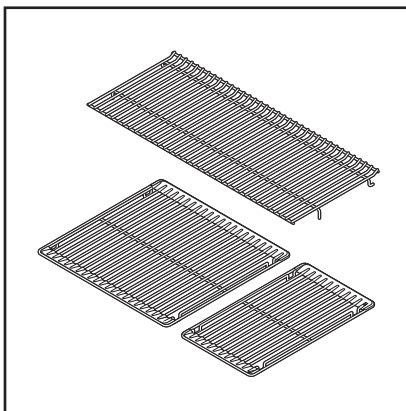

CONSEIL DE PRO : Ne suspendez pas et ne rangez pas les ustensiles de cuisine ou le cordon d'alimentation sur les crochets de la grille. Cela pourrait endommager les ustensiles ou le cordon d'alimentation.

CONNEXION DE VOTRE BARBECUE

Notre engagement à fournir des produits et des expériences de classe mondiale signifie que nous travaillons constamment à améliorer les performances et les fonctionnalités du barbecue. Nous vous recommandons vivement de connecter votre barbecue Traeger Woodridge à WiFIRE en suivant les instructions ci-dessous. Lorsque votre barbecue est connecté et allumé, les mises à jour sont automatiquement téléchargées, ce qui garantit que votre barbecue fonctionne toujours à des performances optimales.

IMPORTANT :

- Assurez-vous que votre appareil intelligent fonctionne avec la dernière version du système d'exploitation et que le Bluetooth est activé.
- Si vous utilisez un appareil Android, activez les services de localisation.
- Pour connecter votre barbecue à votre Wi-Fi domestique, votre barbecue doit être sous tension. Assurez-vous que l'interrupteur d'alimentation principal est en position **MARCHE (I)** et allumé.
- Le signal du routeur de votre Wi-Fi domestique doit être de 2,4 GHz (un routeur double bande devrait également fonctionner). La bande 2,4 GHz est actuellement la norme industrielle pour les appareils connectés. Elle a une meilleure portée et pénètre mieux les murs/plafonds/obstacles que celle de 5 GHz, que votre barbecue ne peut pas reconnaître.

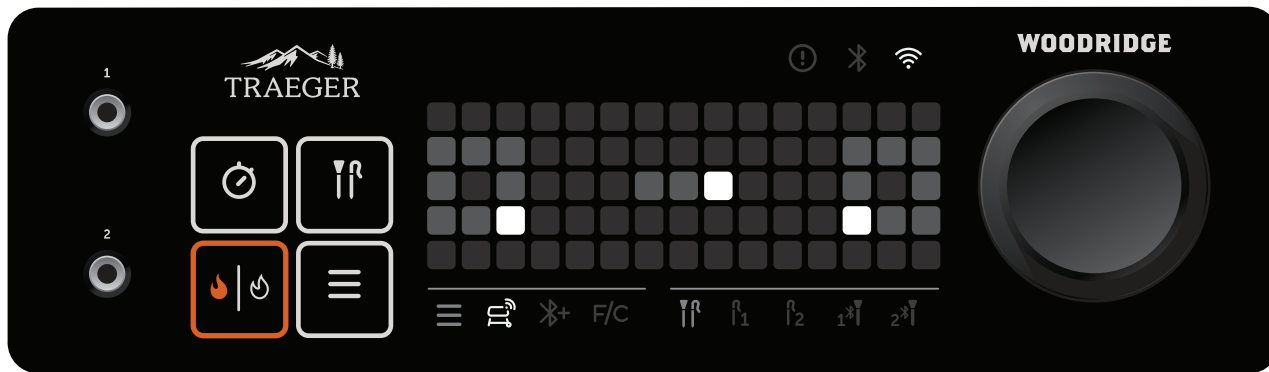

CONSEIL DE PRO : vérifiez sous le couvercle de votre trémie pour un guide de référence rapide et pratique sur votre panneau de commande Woodridge !

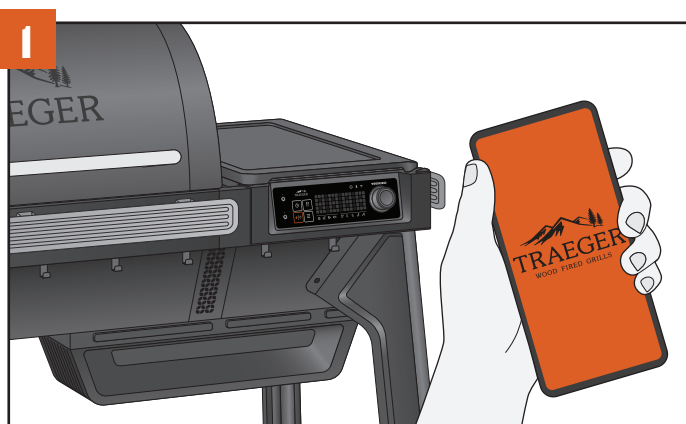

Allez sur l'App Store d'Apple ou sur le Google Play Store d'Android pour télécharger la dernière version de l'appli Traeger.

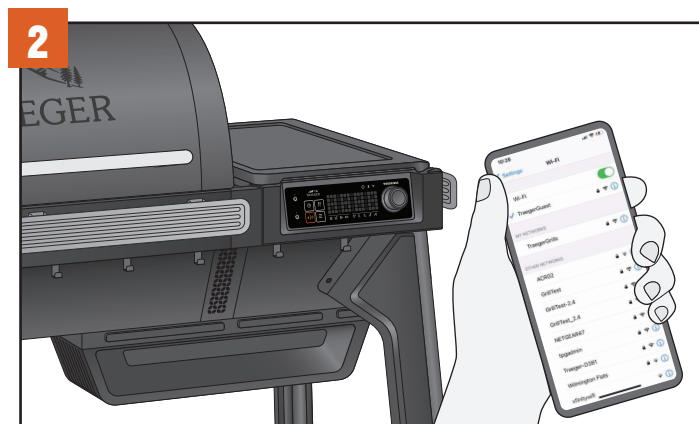

Assurez-vous que votre appareil intelligent est connecté au réseau Wi-Fi auquel vous voulez connecter votre barbecue. Le signal du routeur doit être de 2,4 GHz, car le barbecue n'est pas compatible avec 5 GHz.

CONNEXION DE VOTRE BARBECUE SUITE

3

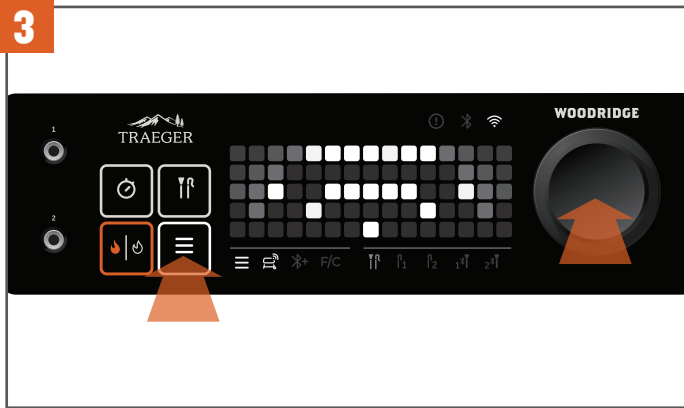

Après avoir allumé votre barbecue, appuyez sur le bouton de menu. Vous verrez l'icône Wi-Fi du barbecue s'allumer dans la barre de menu sous la matrice de points, et une animation d'un signal Wi-Fi avec un point d'interrogation s'affichera. Appuyez sur la molette de sélection pour sélectionner cette option et commencer le processus de connexion.

REMARQUE : Vous pouvez parcourir les options du menu en tournant la molette de sélection après avoir appuyé sur le bouton de menu. Lorsque vous tournez la molette, les icônes de la barre de menu situées sous l'écran à matrice de points s'allument pour indiquer votre sélection.

4



Après avoir sélectionné WiFIRE, l'animation d'appariement ci-dessus s'affichera à l'écran, indiquant que votre barbecue diffuse son signal Bluetooth et est prêt à être apparié. Ouvrez votre appareil intelligent sur l'appli Traeger et connectez-vous à votre compte. Sur l'écran d'accueil de l'appli Traeger, appuyez sur l'icône du barbecue en bas au centre de l'écran pour lancer la connexion.

Suivez les instructions de l'appli Traeger pour (1) appairer votre téléphone à votre barbecue (via une connexion Bluetooth temporaire), (2) connecter votre barbecue à votre réseau Wi-Fi domestique de 2,4 GHz souhaité et (3) terminer le processus de configuration du barbecue.

5

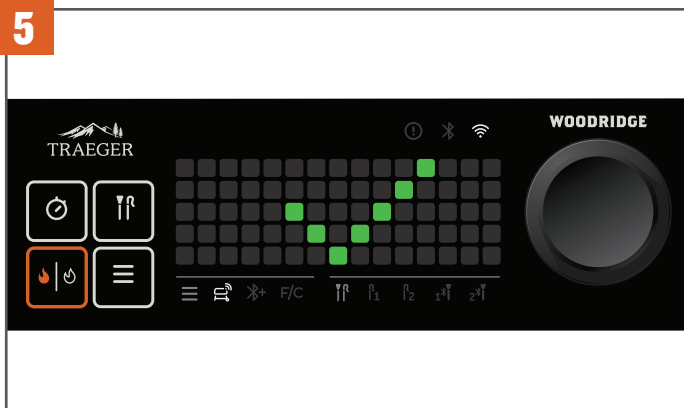

Une coche verte s'affichera sur votre panneau de commande pour indiquer que vous vous êtes connecté avec succès à WiFIRE. L'icône Wi-Fi en haut à droite au-dessus de l'écran à matrice restera allumée lorsque le barbecue est connecté.

6

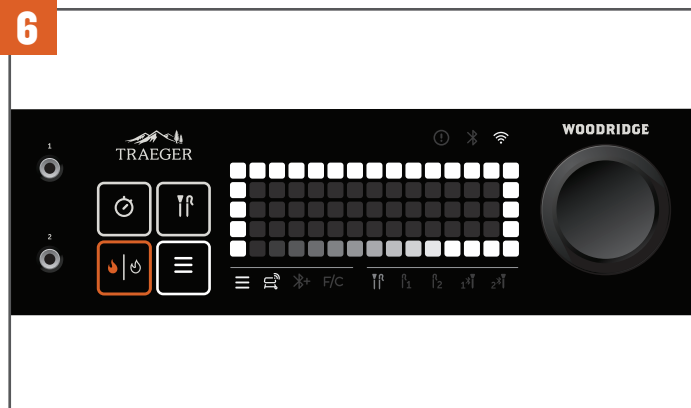

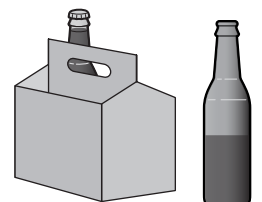

Une fois connecté à WiFIRE, vous pourriez voir cette animation sur votre écran. N'éteignez pas votre barbecue tant que vous ne voyez pas une coche verte. Cela signifie que votre barbecue télécharge et applique une mise à jour. Tout comme votre smartphone, ces mises à jour permettent à votre barbecue de fonctionner correctement, en toute sécurité et à des performances optimales. Une fois la mise à jour terminée, vous verrez une coche verte et le barbecue reviendra en mode veille – cuisinons !

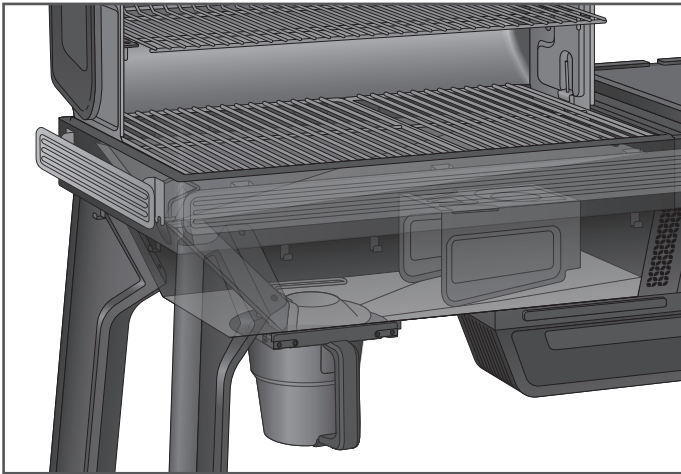

CULOTTAGE DE VOTRE BARBECUE

CONSEIL DE PRO : le culottage doit être effectué avant de cuisiner des aliments sur votre barbecue. Pour plus d'informations, scannez ici pour accéder au Guide de culottage.



IMPORTANT :

- Assurez-vous que tous les composants sont correctement installés dans le barbecue et que tous les matériaux d'emballage/d'expédition sont retirés avant le culottage.
- N'essuyez pas le film de graisse protecteur sur les composants avant le culottage. Ce film offre une couche protectrice plus durable.

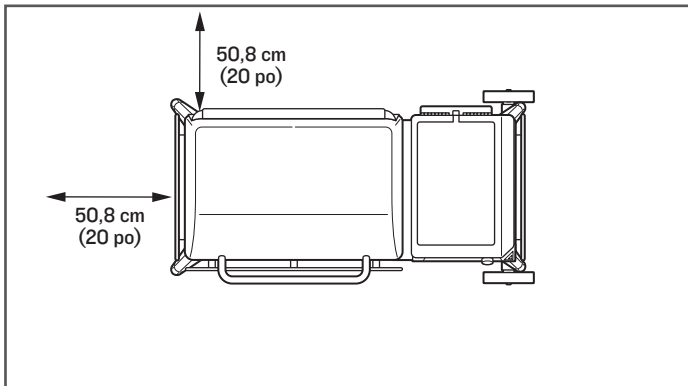

⚠ AVERTISSEMENT Risque d'incendie

- Lorsque le barbecue Traeger est utilisé, il faut maintenir une distance **MINIMUM** de 50,8 cm (20 po) entre le barbecue et tout autre matériau combustible à proximité, y compris les rampes en bois, le revêtement de la maison, les cadres de fenêtres, les meubles, les arbres, les poubelles, etc.

Avant de pouvoir cuisiner sur votre barbecue, celui-ci doit être culotté. Il s'agit d'un processus sans intervention manuelle dans lequel le barbecue vide est chauffé à une température très élevée. Ce cycle de culottage garantit que le barbecue est nettoyé de tout résidu d'usine, préparé et prêt pour des performances optimales.

⚠ DANGER Risque lié au monoxyde de carbone

La combustion de pellets de bois génère du monoxyde de carbone qui peut entraîner des maladies, des blessures graves, voire la mort. Respectez ces directives pour éviter que ce gaz sans couleur ni odeur ne vous intoxique vous et votre famille, vos animaux de compagnie ou autres :

- N'utilisez votre barbecue Traeger qu'à l'extérieur, dans un endroit bien ventilé. Ce barbecue est conçu **UNIQUEMENT POUR UN USAGE EN EXTÉRIEUR**.
- N'utilisez **jamais** le barbecue Traeger dans un endroit clos ou sans aération adéquate.
- Il faut connaître les symptômes d'une intoxication au monoxyde de carbone : maux de tête, étourdissements, faiblesse, nausées, vomissements, somnolence et confusion. Le monoxyde de carbone réduit la capacité du sang à transporter l'oxygène. De faibles niveaux d'oxygène dans le sang entraînent une perte de conscience et la mort.
- Consultez un médecin si vous ou quelqu'un d'autre présente des symptômes de type rhume ou grippe lorsque vous cuisinez ou que vous êtes à proximité de cet appareil. Une intoxication au monoxyde de carbone, facilement confondue avec un rhume ou une grippe, est souvent détectée trop tard.
- La consommation d'alcool ou de médicaments augmente les effets de l'intoxication au monoxyde de carbone.
- Le monoxyde de carbone est particulièrement toxique pour les mères et leur bébé pendant la grossesse, pour les nouveau-nés, les personnes âgées, les fumeurs, et les personnes présentant des problèmes du sang ou de circulation sanguine, comme l'anémie ou les affections cardiaques.

⚠ AVERTISSEMENT Risque d'incendie

- **Ne jamais** utilisez d'essence, de combustible de lanterne de type essence, de kérosène, de l'essence pour briquet, ou d'autres matériaux inflammables pour allumer ou « raviver » un feu.
- **Ne jamais** utilisez ou stocker de liquides ou d'autres matériaux inflammables à proximité du barbecue.

⚠ AVERTISSEMENT Risque de brûlures

Les cendres doivent toujours être complètement refroidies avant d'être manipulées. Les cendres doivent être placées dans un récipient en métal avec un couvercle hermétique. Le récipient à cendres fermé doit être placé sur une surface non combustible ou par terre, à distance de tout matériau combustible, avant l'élimination finale. Les cendres doivent être conservées dans le récipient fermé jusqu'à leur élimination.

⚠ AVERTISSEMENT N'utilisez pas de pellets de combustible

N'utilisez jamais de pellets de combustible dans le barbecue, car ils peuvent contenir des contaminants et des additifs dangereux et endommager le barbecue.

CULOTTAGE DE VOTRE BARBECUE SUITE

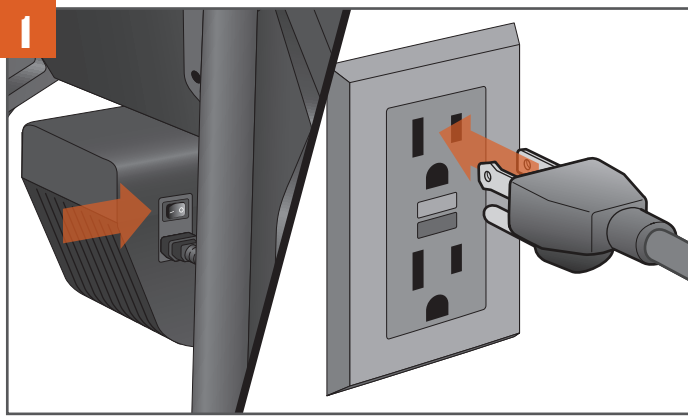

Avec l'interrupteur d'alimentation principal en position **ARRÊT (0)**, connectez le cordon d'alimentation à votre barbecue. Branchez ensuite le cordon d'alimentation sur une prise électrique correctement mise à la terre et protégée par un disjoncteur de fuite à la terre (GFCI).

REMARQUE : l'aspect de la prise peut varier selon la région.



AVERTISSEMENT ! RISQUE DE CHOC ÉLECTRIQUE
UNE TENSION DANGEREUSE EST PRÉSENTE ET ELLE PEUT PROVOQUER UN CHOC, UNE BRÛLURE OU LA MORT.

- UNE PROTECTION PAR DISJONCTEUR DE FUITE À LA TERRE (GFCI) DOIT ÊTRE FOURNIE SUR LES CIRCUITS OU LES PRISES À UTILISER POUR LE FONCTIONNEMENT DE CE BARBECUE TRAEGER.

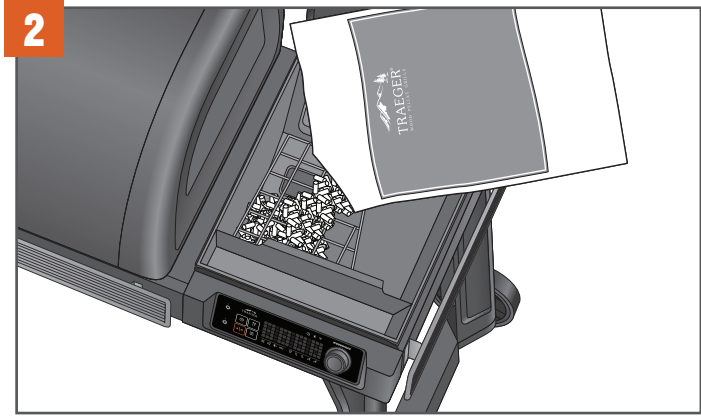

Pour ajouter des granules, ouvrez le couvercle de la trémie et vérifiez s'il y a des corps étrangers dans la vis sans fin. Remplissez la trémie de granules au moins jusqu'à la grille de sécurité et fermez le couvercle.

UTILISEZ UNIQUEMENT DES GRANULES À BOIS DUR TRAEGER. Ce produit est développé et réglé en utilisant uniquement des granules Traeger. Les granules Traeger sont fabriqués pour répondre à des normes strictes de qualité et de performance. L'utilisation de granules non fabriqués par Traeger peut entraîner des performances irrégulières, une saveur médiocre et des écarts de température.

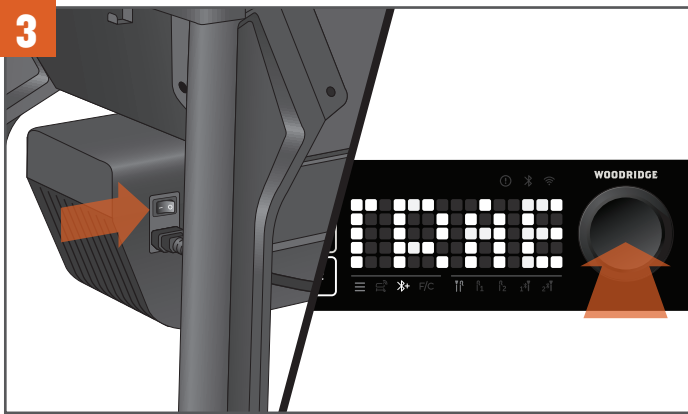

Appuyez sur l'interrupteur d'alimentation principal, situé à l'arrière du boîtier de la vis sans fin, pour mettre en **MARCHE (I)**. Appuyez sur la molette de sélection pour réveiller le panneau de commande. « TRAEGER » défilera sur l'écran, indiquant que le barbecue est allumé.



Tournez la molette de sélection pour régler la température du barbecue à 350 °F (177 °C), puis appuyez sur la molette. Appuyez sur le bouton d'allumage/extinction.



CONSEIL DE PRO : ce processus de culottage est important pour garantir le bon fonctionnement du barbecue. Assurez-vous que tous les composants internes ont été correctement installés avant ce cycle de culottage et qu'aucun aliment ne se trouve sur les grilles du barbecue pendant ce processus.



5 La température du barbecue s'affichera à mesure qu'elle augmentera jusqu'à la température réglée.

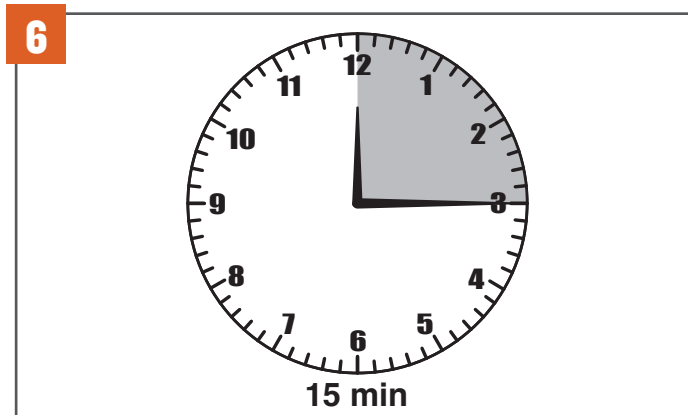

6 Une fois que le barbecue a atteint 350 °F (177 °C), laissez-le fonctionner pendant 15 minutes. Pendant le culottage du barbecue, vous pouvez observer une fumée et des cendres foncées ou excessives ; cela est normal et sera moins important lors des prochains démarrages.



7 Après 15 minutes à 350 °F (177 °C), augmentez la température à 500 °F (260 °C).

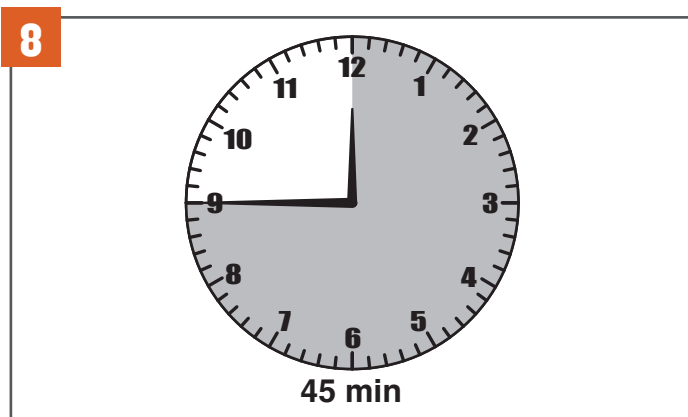

8 Une fois que le barbecue a atteint 500 °F (260 °C), laissez-le fonctionner pendant 45 minutes supplémentaires pour vous assurer que le culottage est terminé correctement.

REMARQUE : atteindre la température de culottage pour la première fois peut prendre jusqu'à une heure.

CULOTTAGE DE VOTRE BARBECUE SUITE



Après 45 minutes à 500 °F (260 °C), éteignez le barbecue et laissez le cycle d'extinction se terminer. Pour éteindre votre barbecue, appuyez sur le bouton d'allumage/extinction ou sur la molette de sélection maintenez enfoncé pendant trois secondes jusqu'à ce que l'écran affiche l'animation d'extinction.

REMARQUE : lancez toujours un cycle d'extinction après chaque cuisson.

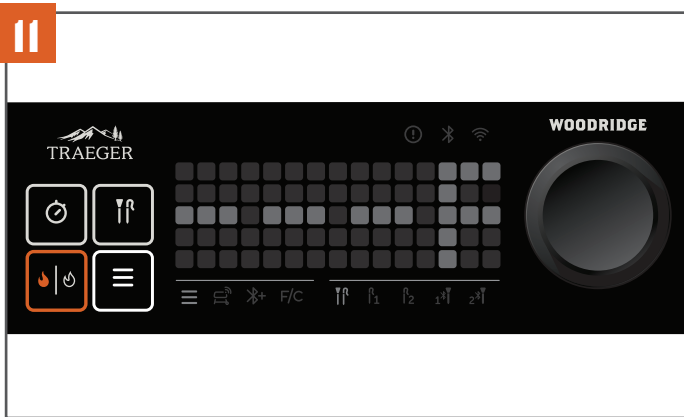

Une fois ce compte à rebours terminé, le cycle d'extinction est terminé.

REMARQUE : il est normal d'observer des cendres sur le plateau d'égouttement et/ou les grilles du barbecue après le culottage. Essayez simplement les cendres sur les grilles du barbecue avant votre première cuisson.



Un compte à rebours démarre pendant que le barbecue s'éteint. Vous entendrez le ventilateur continuer à fonctionner.

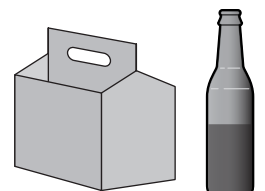



REMARQUES





MONTAGEANLEITUNG

WOODRIDGE HOLZPELLETGRILL



**HIER SCANNEN
FÜR EINE SCHRITTWEISE
ANIMIERTE
ANLEITUNG**

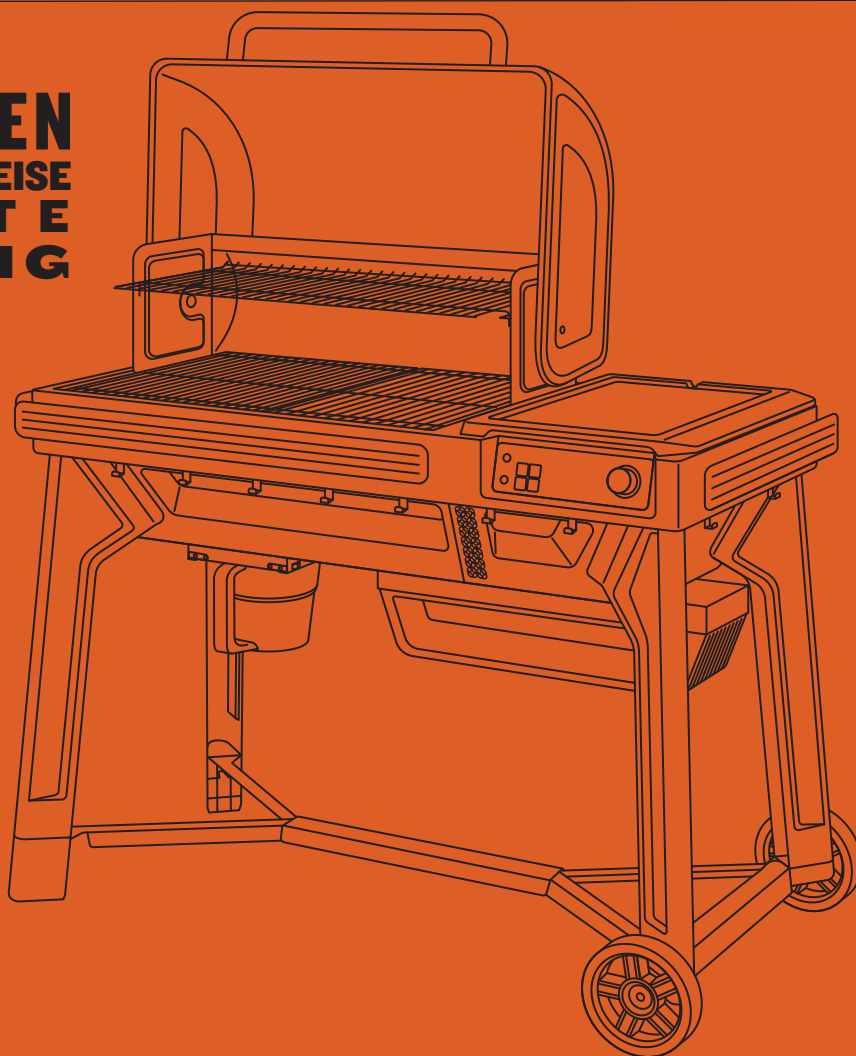

EINE DER HAUPTURSACHEN FÜR BRÄNDE IST DIE NICHTEINHALTUNG DER ERFORDERLICHEN ABSTÄNDE (LUFTRÄUME) ZU BRENNBAREN MATERIALIEN. ES IST ÄUSSERST WICHTIG, DASS DIESES PRODUKT NUR GEMÄSS DIESER ANLEITUNG AUFGEBAUT WIRD.

WICHTIG: ANLEITUNG FÜR SPÄTERE VERWENDUNG AUFBEWAHREN. ANLEITUNG SORGFÄLTIG DURCHLESEN.

T18983

©2025 TRAEGER PELLET GRILLS LLC.
ALLE RECHTE VORBEHALTEN.

TRAEGER PELLET GRILLS LLC

533 South 400 West
Salt Lake City, UT 84101

TRAEGER.COM

VOR DER MONTAGE

BITTE LESEN SIE DIESE MONTAGEANLEITUNG UND DIE BETRIEBSANLEITUNG VOR DER INSTALLATION UND VERWENDUNG IHRES TRÄGERGRILLS. DIE NICHTBEACHTUNG DER ANWEISUNGEN IN DIESER MONTAGEANLEITUNG UND DER BETRIEBSANLEITUNG KANN ZU SACHSCHÄDEN, PERSONENSCHÄDEN ODER SOGAR ZUM TOD FÜHREN.

Achten Sie darauf, dass beim Grillen ein Mindestabstand von 50,8 cm (20 Zoll) zu brennbaren Gegenständen in der Nähe besteht, z. B. zu Holzgeländern, Hausverkleidungen, Fensterrahmen, Möbeln, Bäumen, Mülleimern usw. Installieren und betreiben Sie diesen Grill nicht auf brennbaren Böden oder Oberflächen, in Innenräumen oder unter brennbaren Zimmerdecken oder Überhängen. Weitere Anweisungen und Warnungen finden Sie in der Bedienungsanleitung.

MONTAGE-BEREICH

PROFI-TIPP: Montieren Sie den Grill auf der Unterseite des Versandkartons, um Kratzer zu vermeiden.

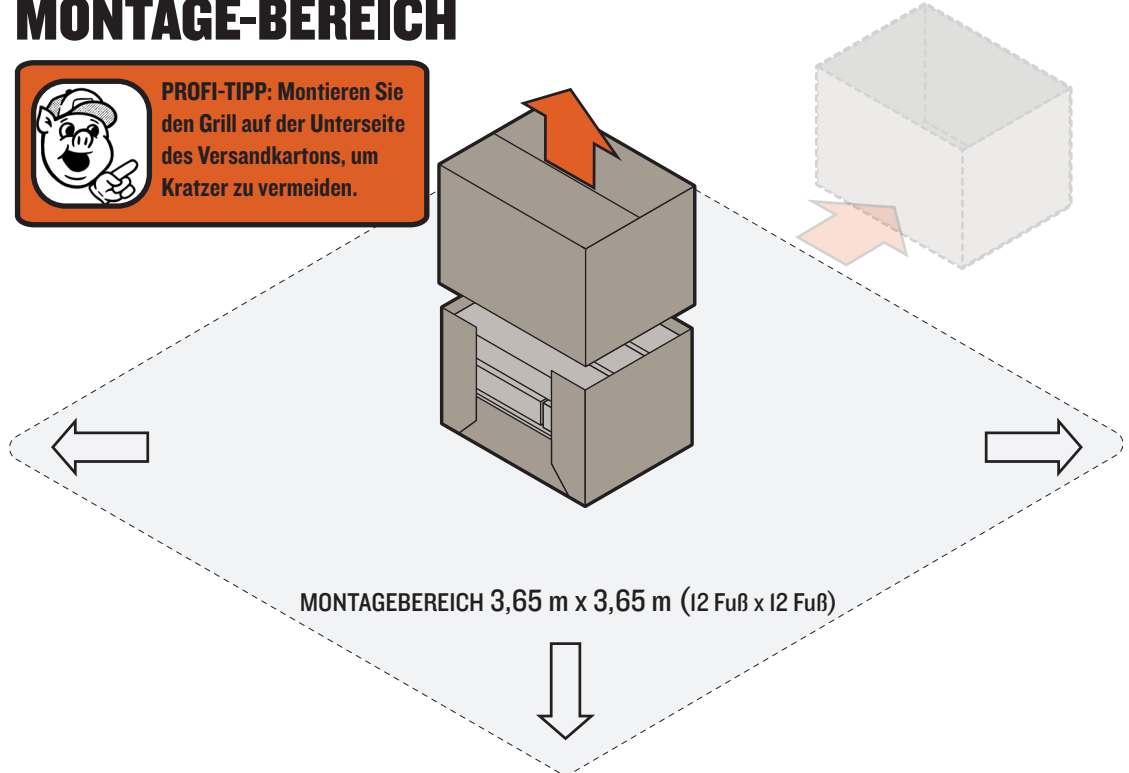

PROFI-TIPP: Wir empfehlen, den Aufbau des Grills zu zweit durchzuführen.

MONTAGE

Nachdem alle Komponenten ausgepackt sind, legen Sie die Teile auf die Unterseite des Versandkartons.

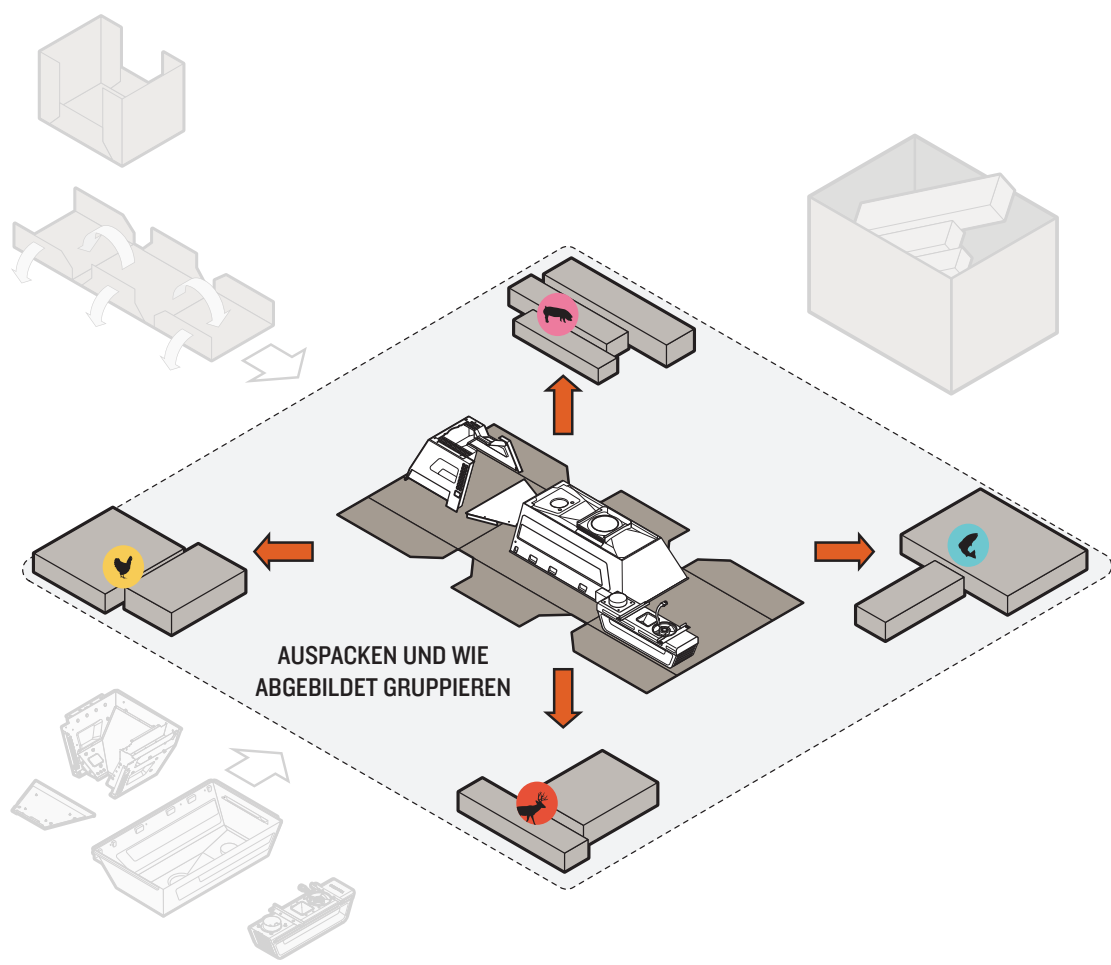

GRUPPIEREN SIE DIE SCHACHTELN ANHAND IHRER KENNZEICHNUNGEN, WIE UNTEN DARGESTELLT:

-  FÄCHER & BEINE
-  RÄDER & STANDFÜSSE
-  BEDIENELEMENTE UND ABLAGEN
-  DECKEL & INNENTEILE DES GRILLS



BEFESTIGUNGSTEILE (GESAMTMENGEN)

MASSSTAB 1:1

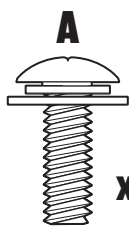

x 32 x 2 extra

1/4
20
0,75 Zoll.

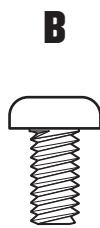

x 61 x 4 extra

1/4
20
0,5 Zoll.

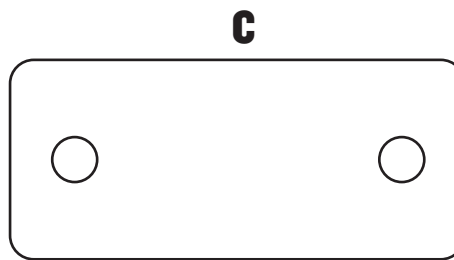

MONTAGE-
PLATTE

x 4

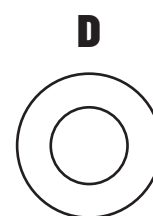

x 2

0,375
UNTERLEG-
SCHEIBE



x 2 x 1 extra

RUNDER
SPLINT



x 2

0,375
SPLINT-
BOLZEN

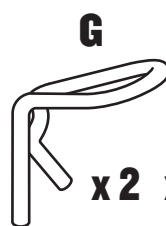

x 2 x 1 extra

120 °
SPLINT



x 2 extra

SILIKON-
STOSSFÄNGER



KAPITEL

KAPITEL 1 – SEITE 5

FÄCHER & BEINE

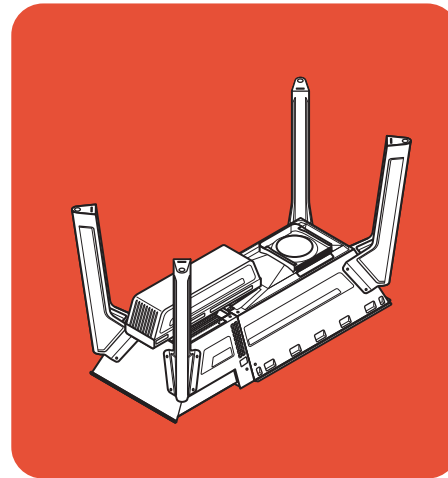

KAPITEL 2 – SEITE 13

RÄDER & STANDFÜSSE

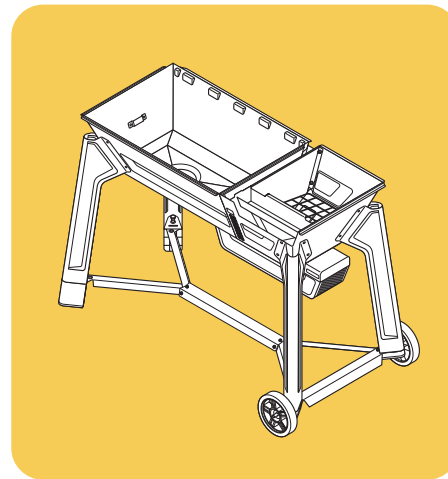
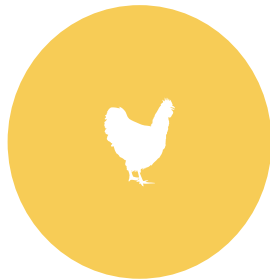

KAPITEL 3 – SEITE 19

BEDIENELEMENTE UND ABLAGEN

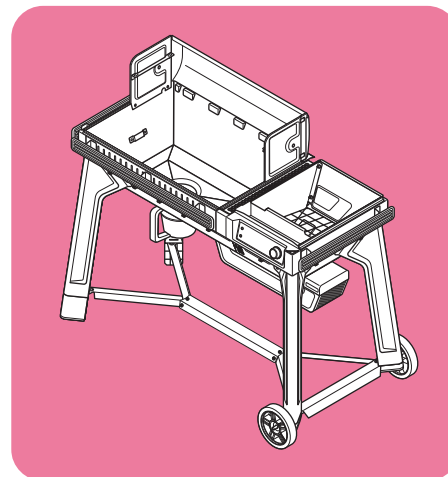

KAPITEL 4 – SEITE 31

DECKEL & INNENTEILE DES GRILLS

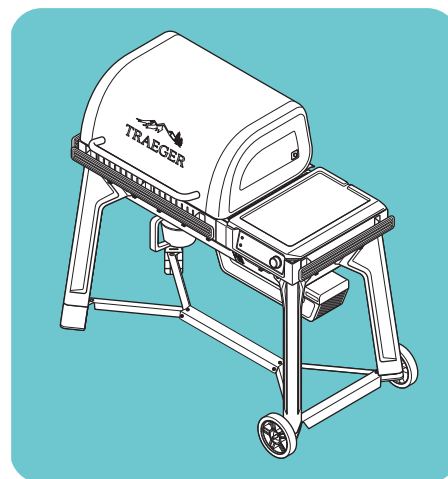

KAPITEL I

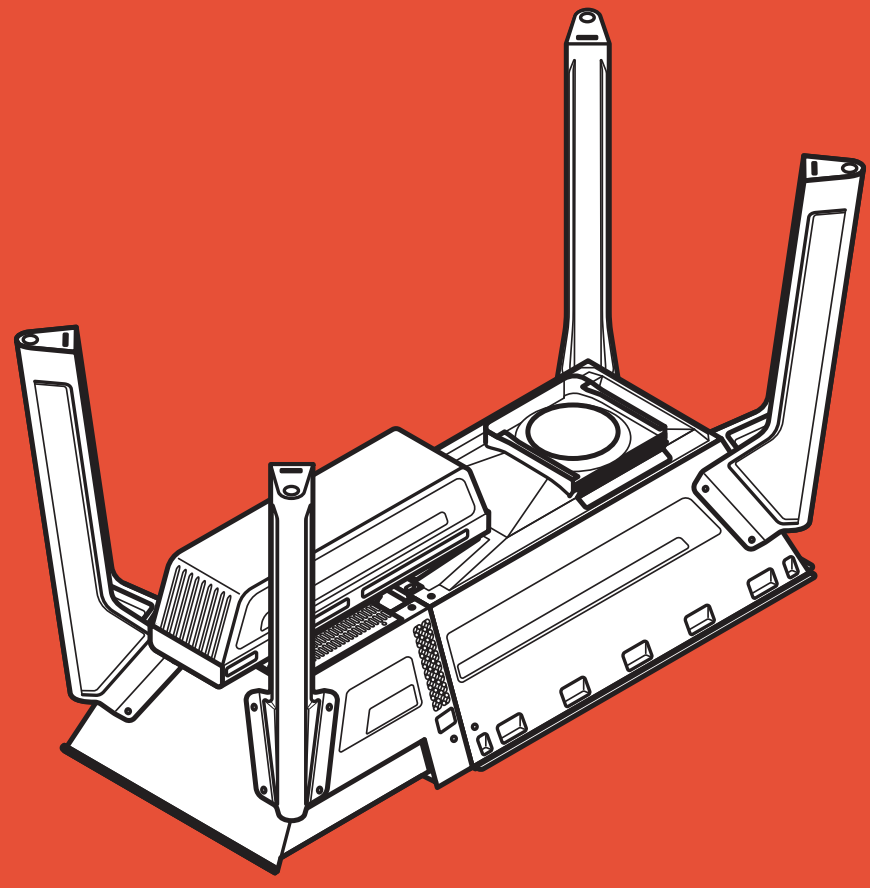

FÄCHER & BEINE

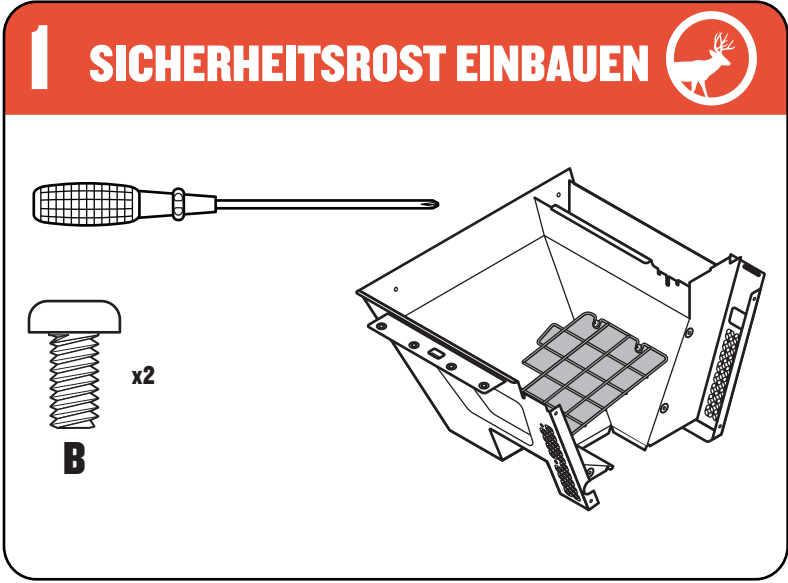
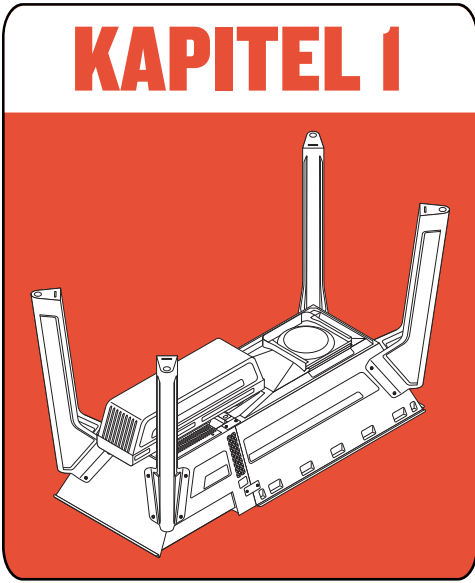

PROFI-TIPP: Ziehen Sie alle Schrauben zunächst handfest an und ziehen Sie sie dann mit einem Schraubendreher fest.

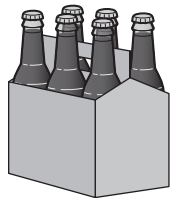
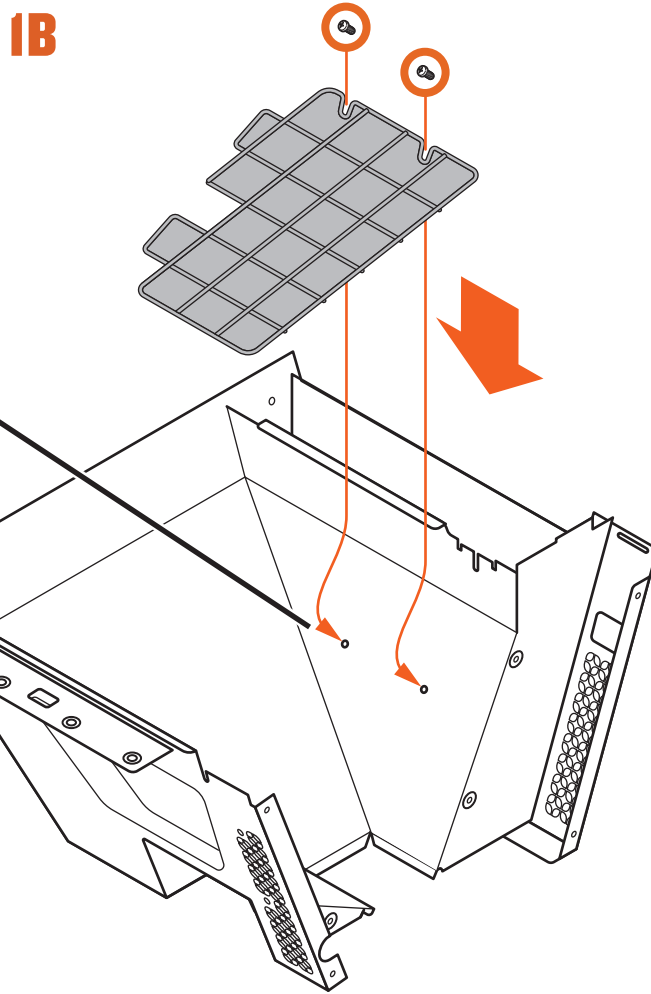
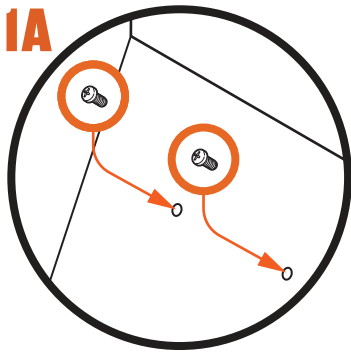

6





2 PELLETKAMMER ZUSAMMENBAUEN

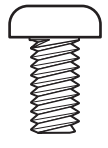
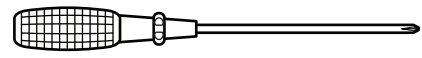

x9

B

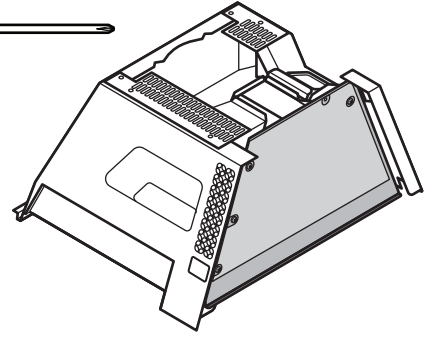

2A

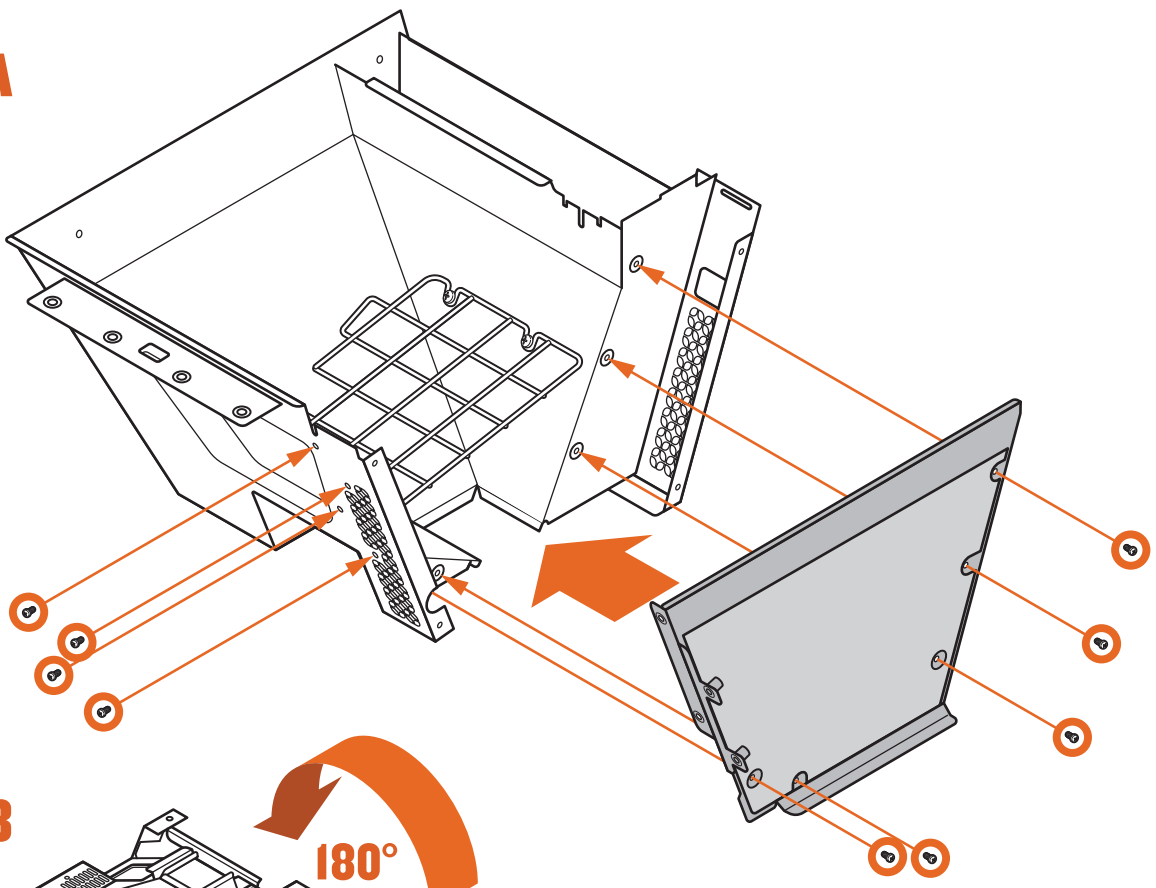

2B

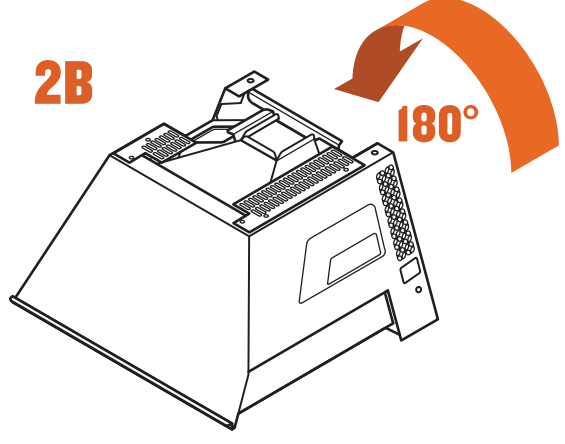



3A PELLETKAMMER AM GEHÄUSE ANBRINGEN

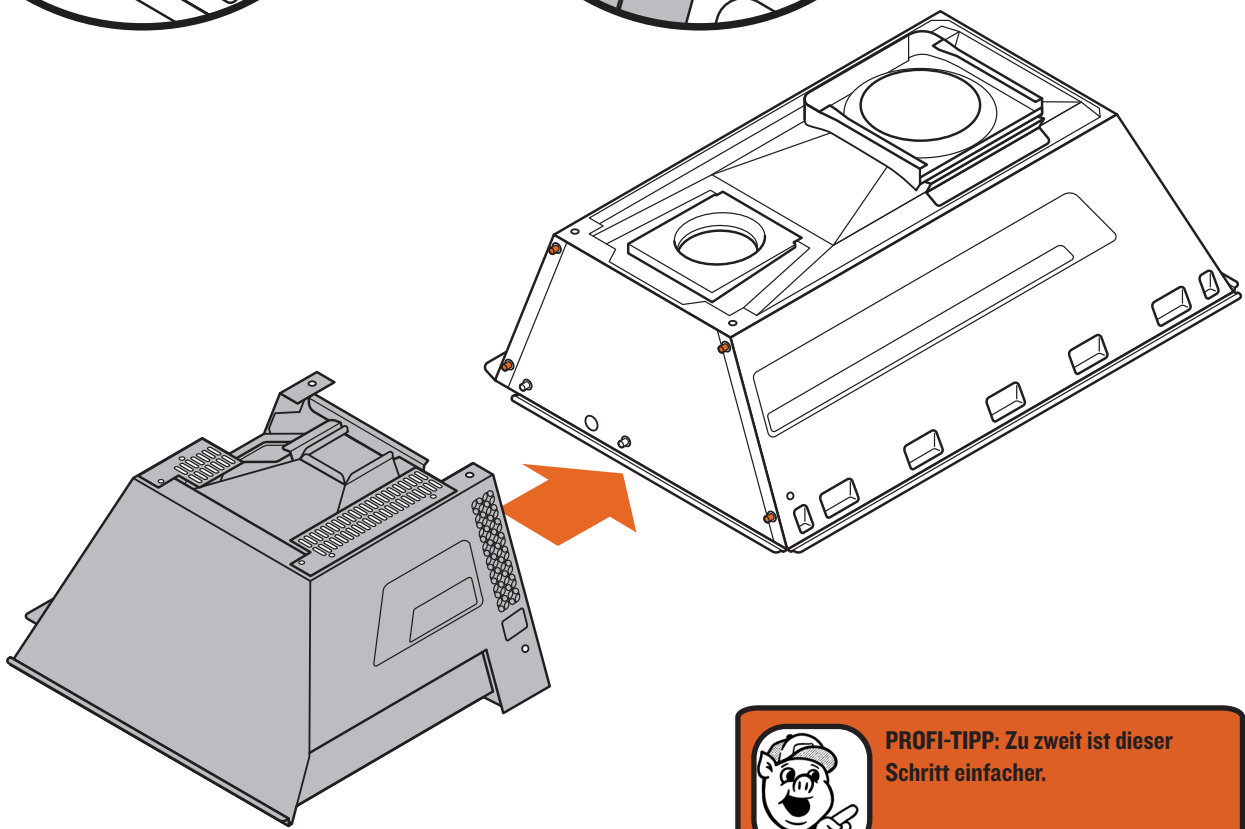
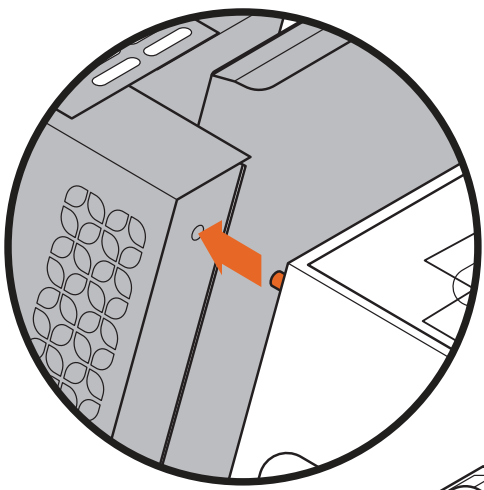
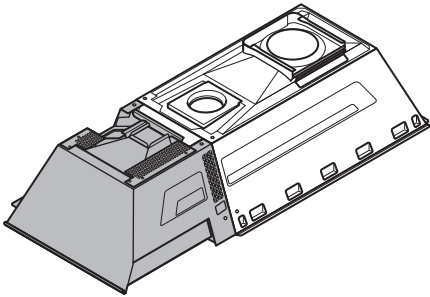

 **PROFI-TIPP:** Zu zweit ist dieser Schritt einfacher.





3B PELLETKAMMER AM GEHÄUSE ANBRINGEN

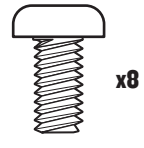
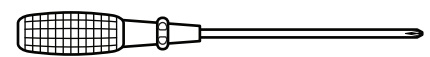

B

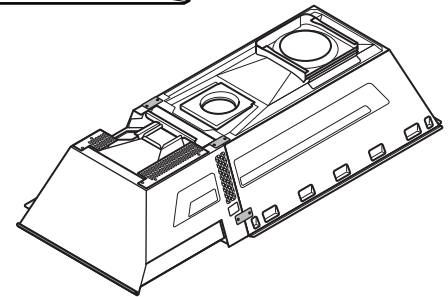

x4

C

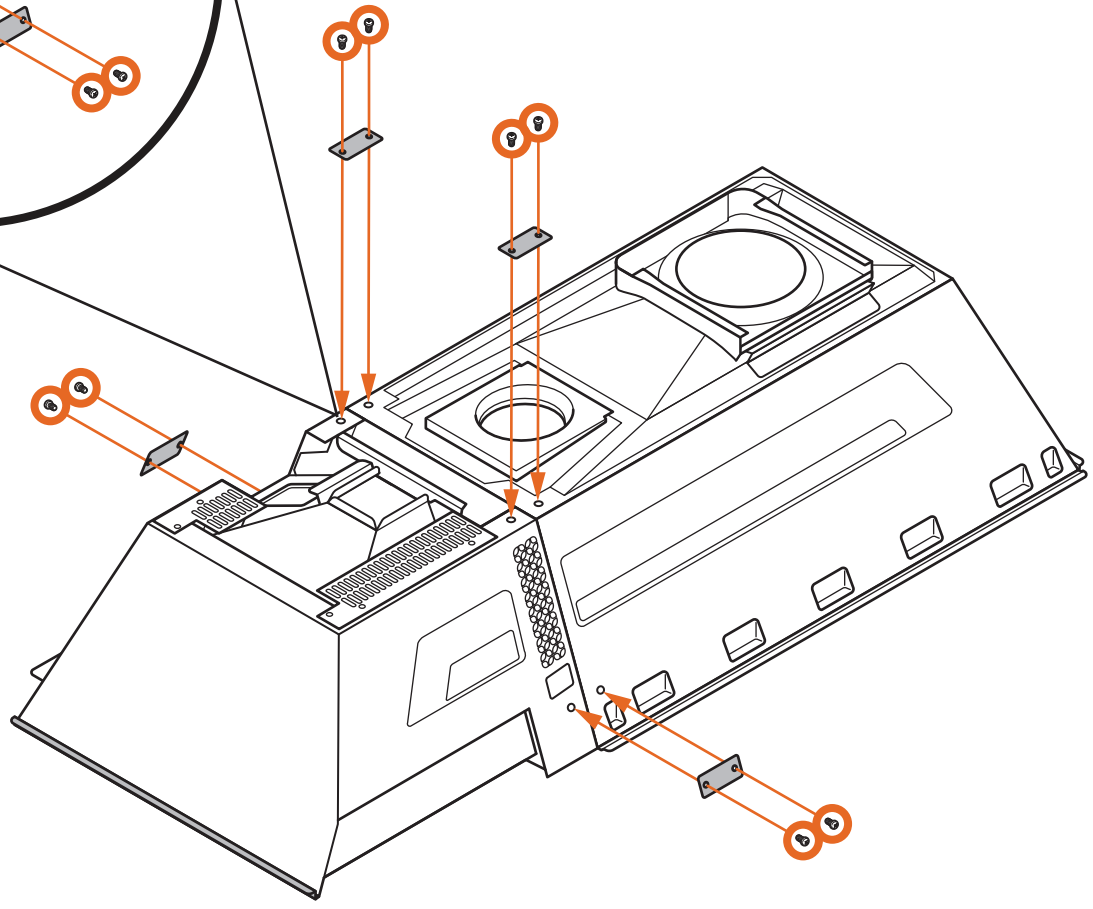
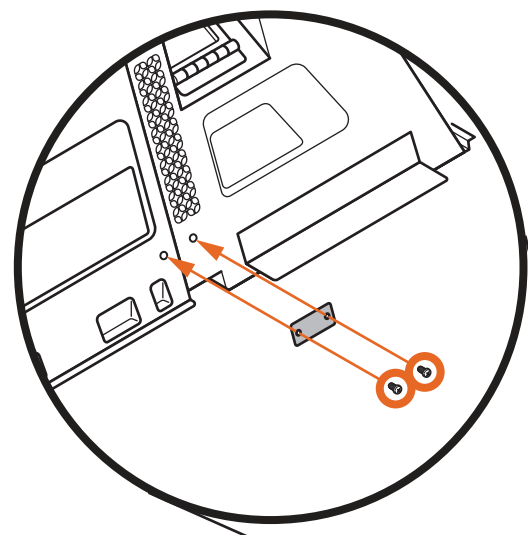



4 FÖRDERSCNECKENGEHÄUSE ANSCHLIESSEN



12-POLIGER STECKER

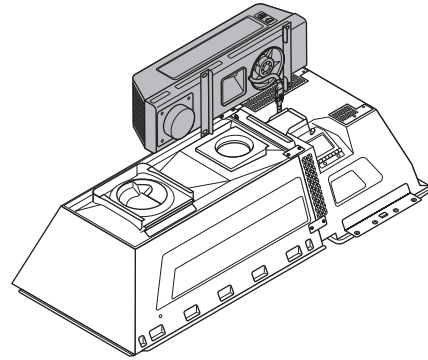
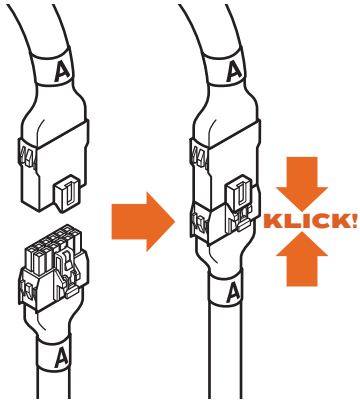
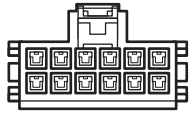

PROFI-TIPP: Lassen Sie das Förderschneckengehäuse von einer zweiten Person festhalten, während Sie das Kabel anschließen.



PROFI-TIPP: Vergessen Sie nicht, den Binddraht und das Klebeband zu entfernen, mit denen das Kabel befestigt ist.

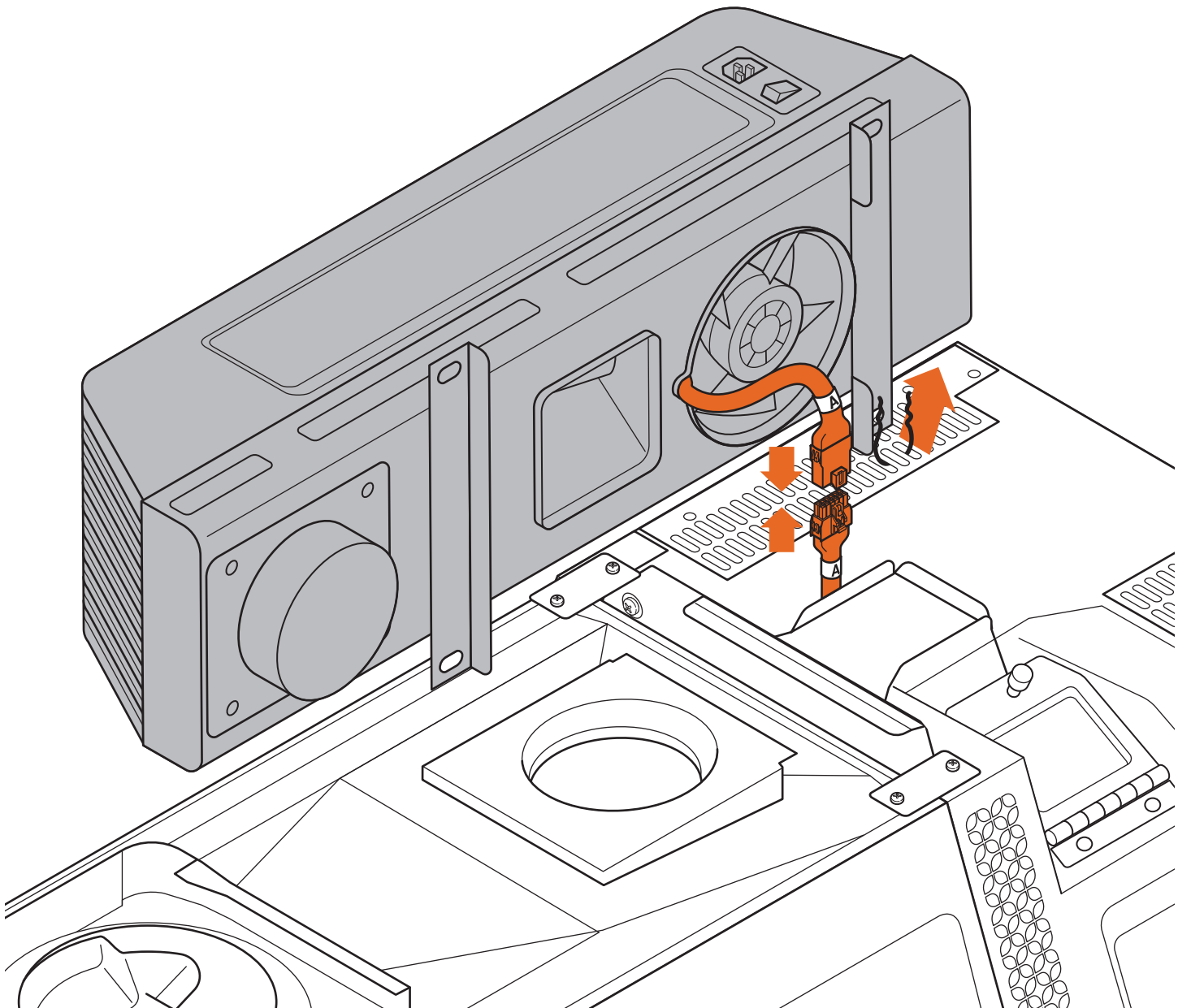



5 FÖRDERSCNECKENGEHÄUSE ANBRINGEN

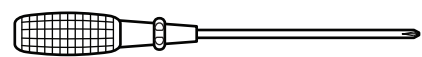

Verwenden Sie jetzt
DIESE Schraube!

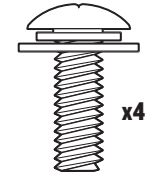

A

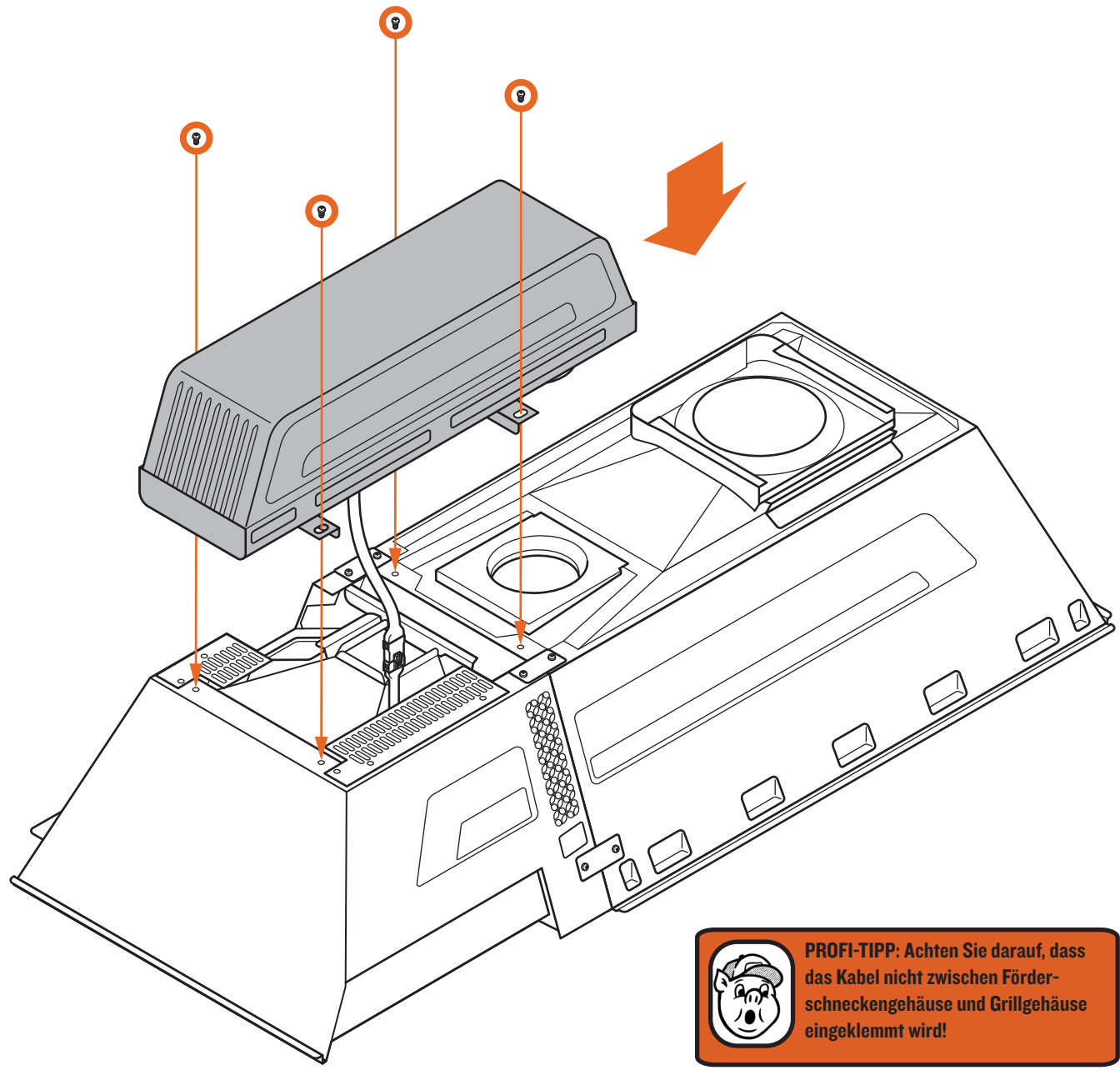
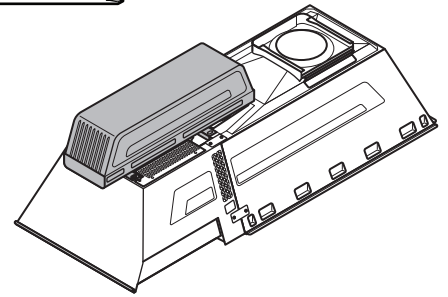

PROFI-TIPP: Achten Sie darauf, dass das Kabel nicht zwischen Förder-
schneckengehäuse und Grillgehäuse
eingeklemmt wird!



6 BEINE ANBRINGEN

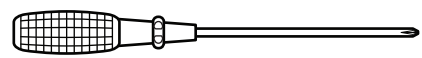

Verwenden Sie wieder
DIESE Schraube!

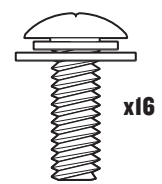

A

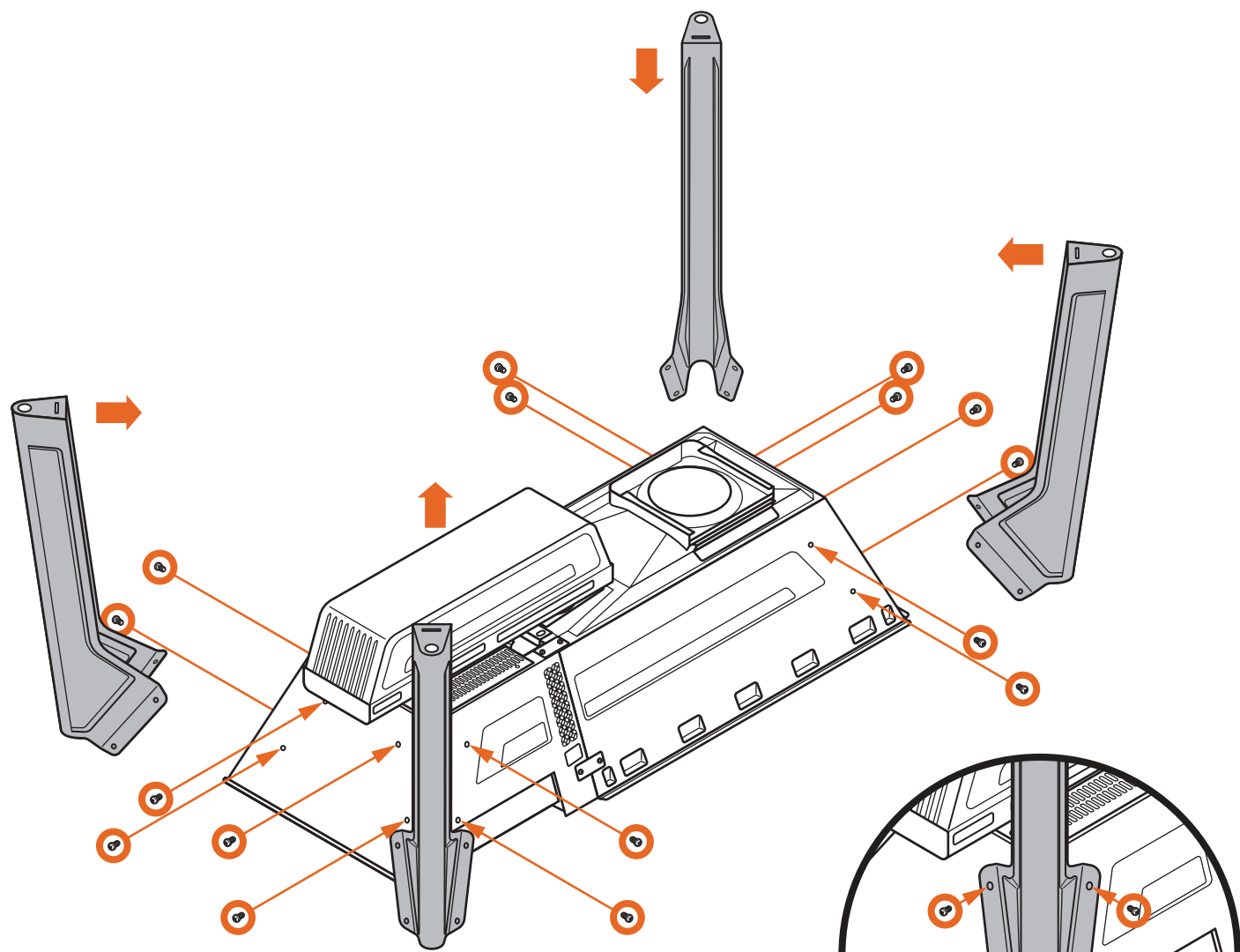
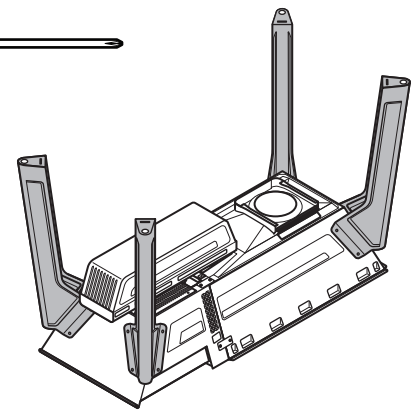

 **PROFI-TIPP:** Sie können die Beine leicht zusammendrücken, um die Schrauben auszurichten, bevor Sie sie mit einem Schraubendreher festziehen.

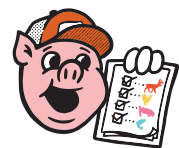

**GUTE ARBEIT!
KAPITEL I ABGESCHLOSSEN!**

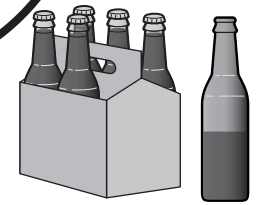

KAPITEL 2

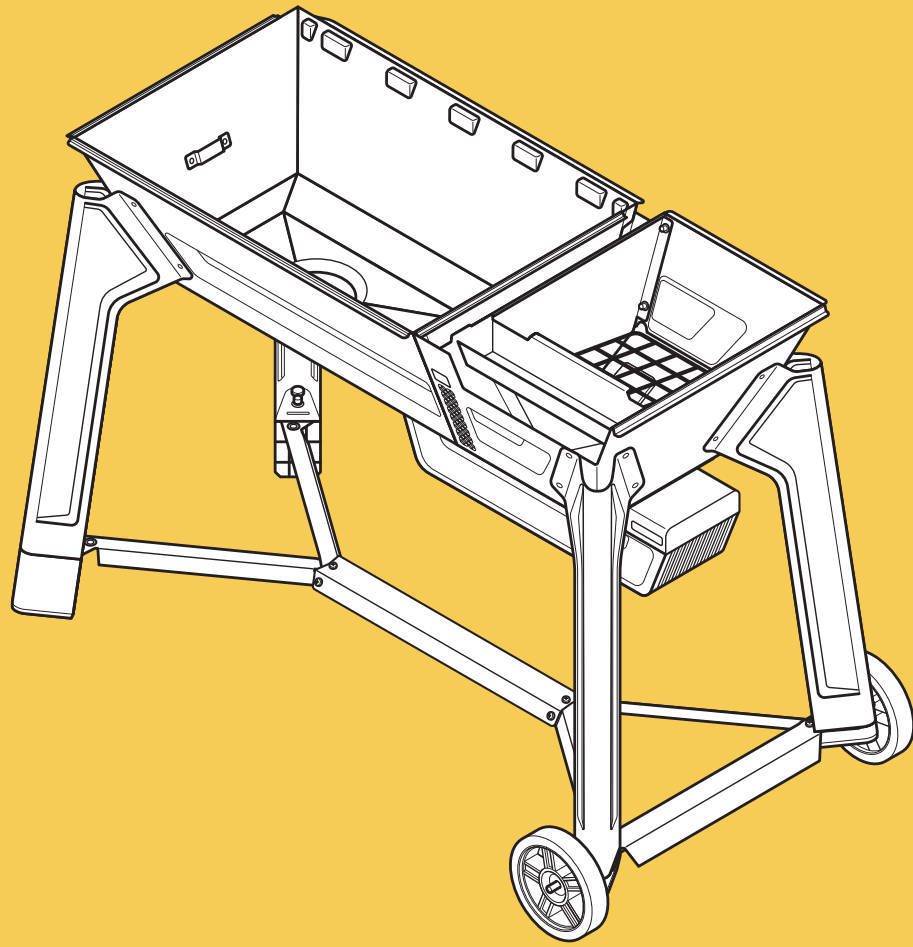

RÄDER & STANDFÜSSE

KAPITEL 2

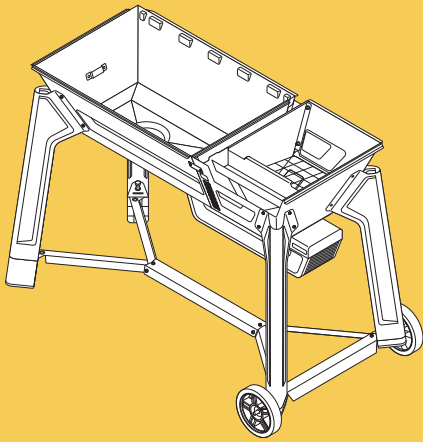

1 STREBE/ACHSABDECKUNG MONTIEREN

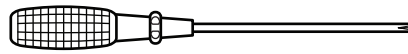

Verwenden Sie wieder
DIESE Schraube!

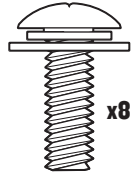

A

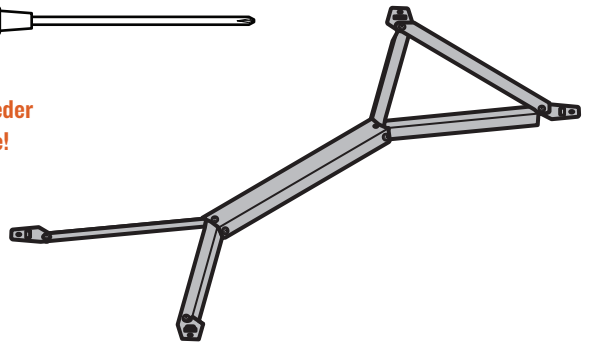

PROFI-TIPP: Ziehen Sie alle Schrauben zunächst handfest an und ziehen Sie sie dann mit einem Schraubendreher fest.

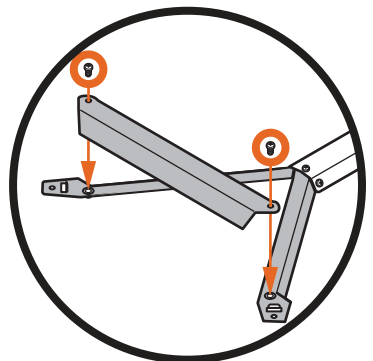
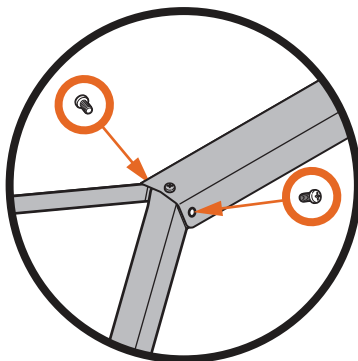
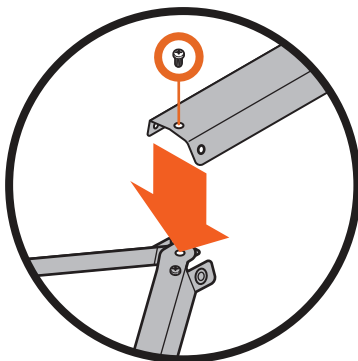
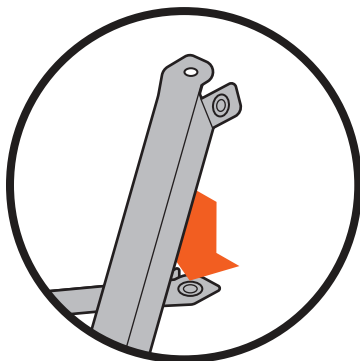
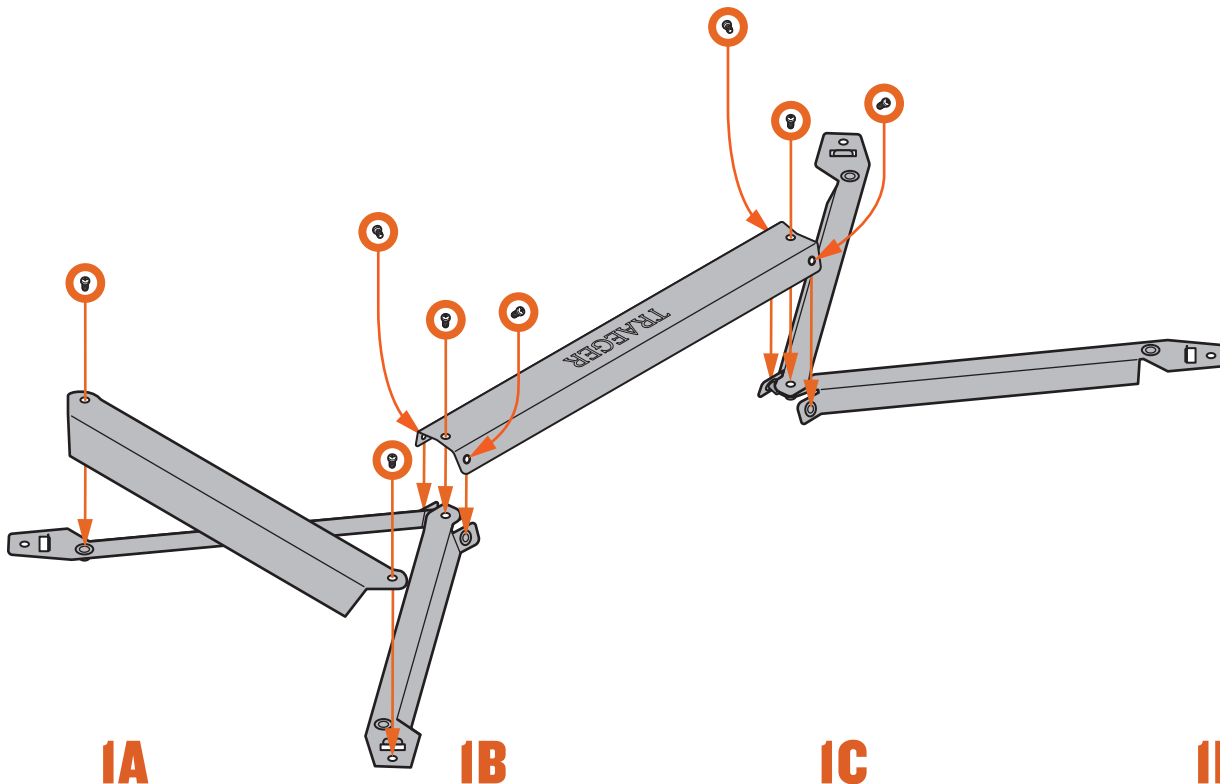

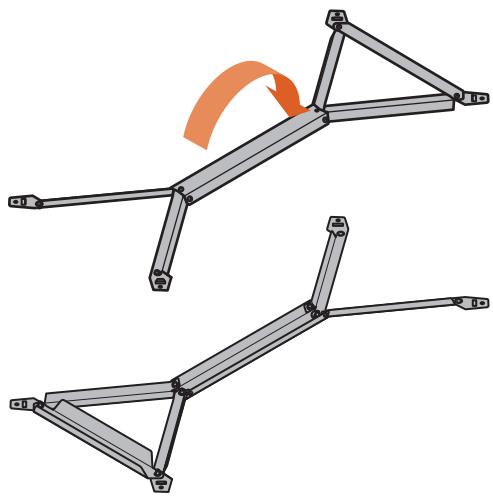

2 STREBE/ACHSABDECKUNG ANBRINGEN

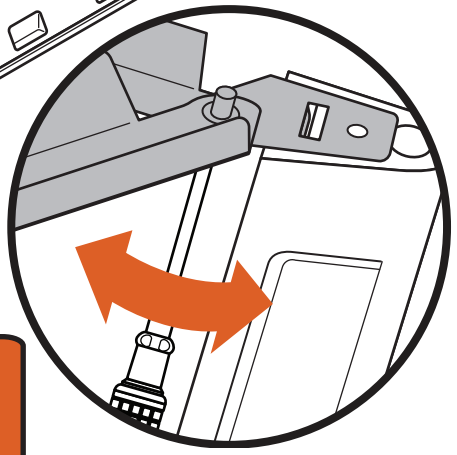
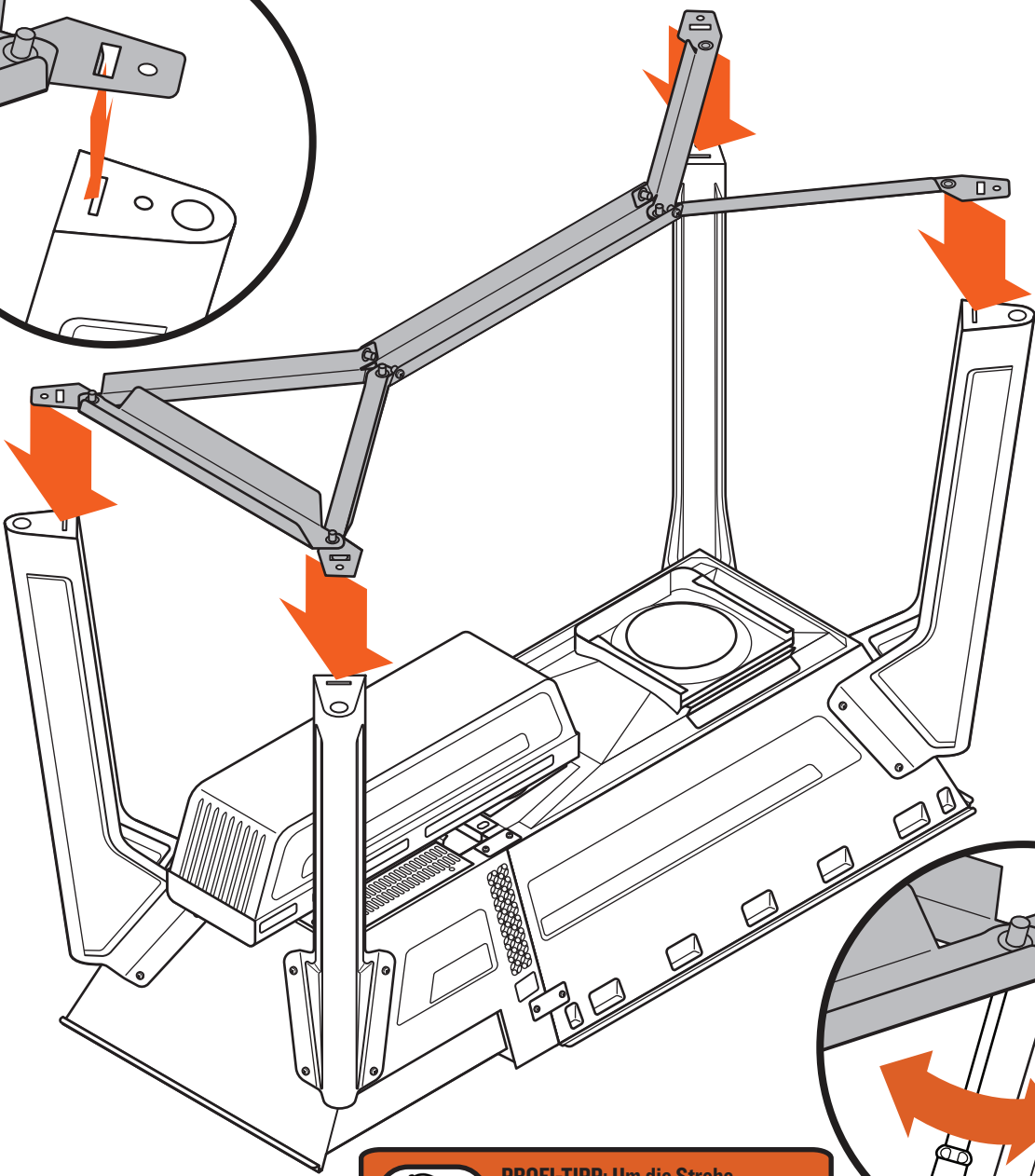
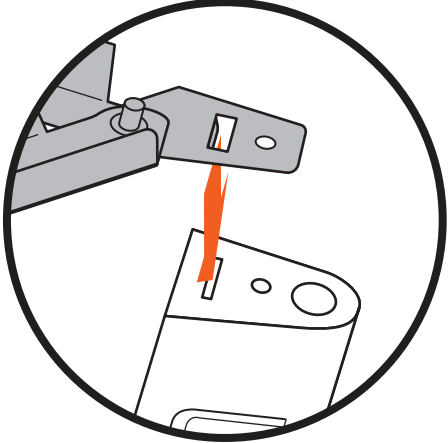
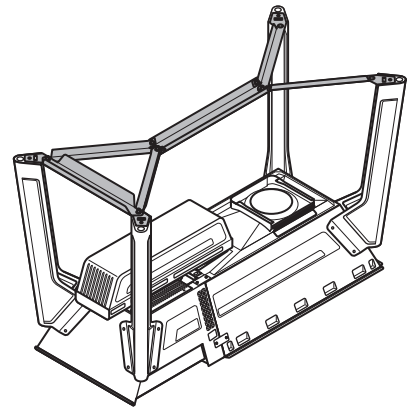

PROFI-TIPP: Um die Strebe anzupassen, können Sie die Schrauben nach Bedarf lösen und festziehen.

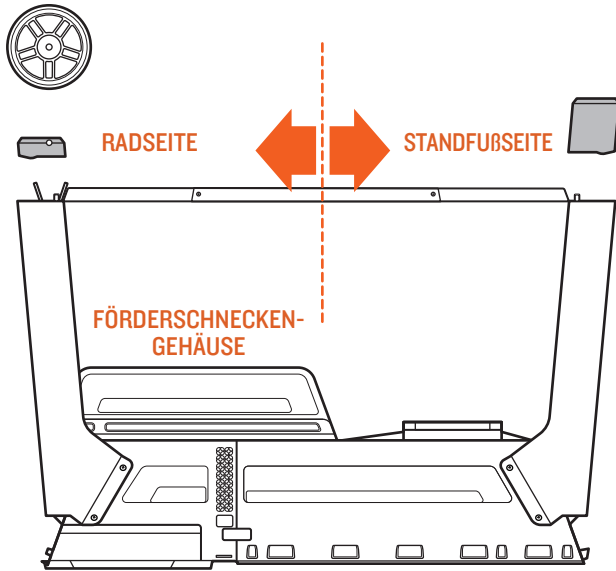

3 STANDFÜSSE ANBRINGEN

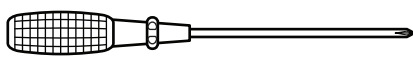

Verwenden Sie wieder **DIESE** Schraube!

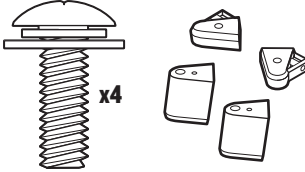

x4

A

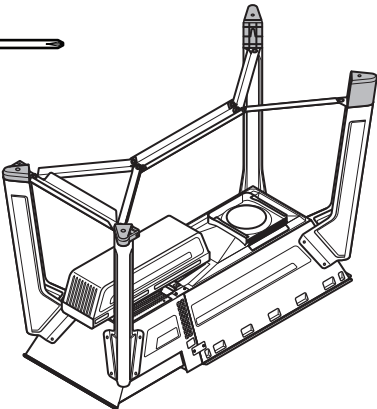

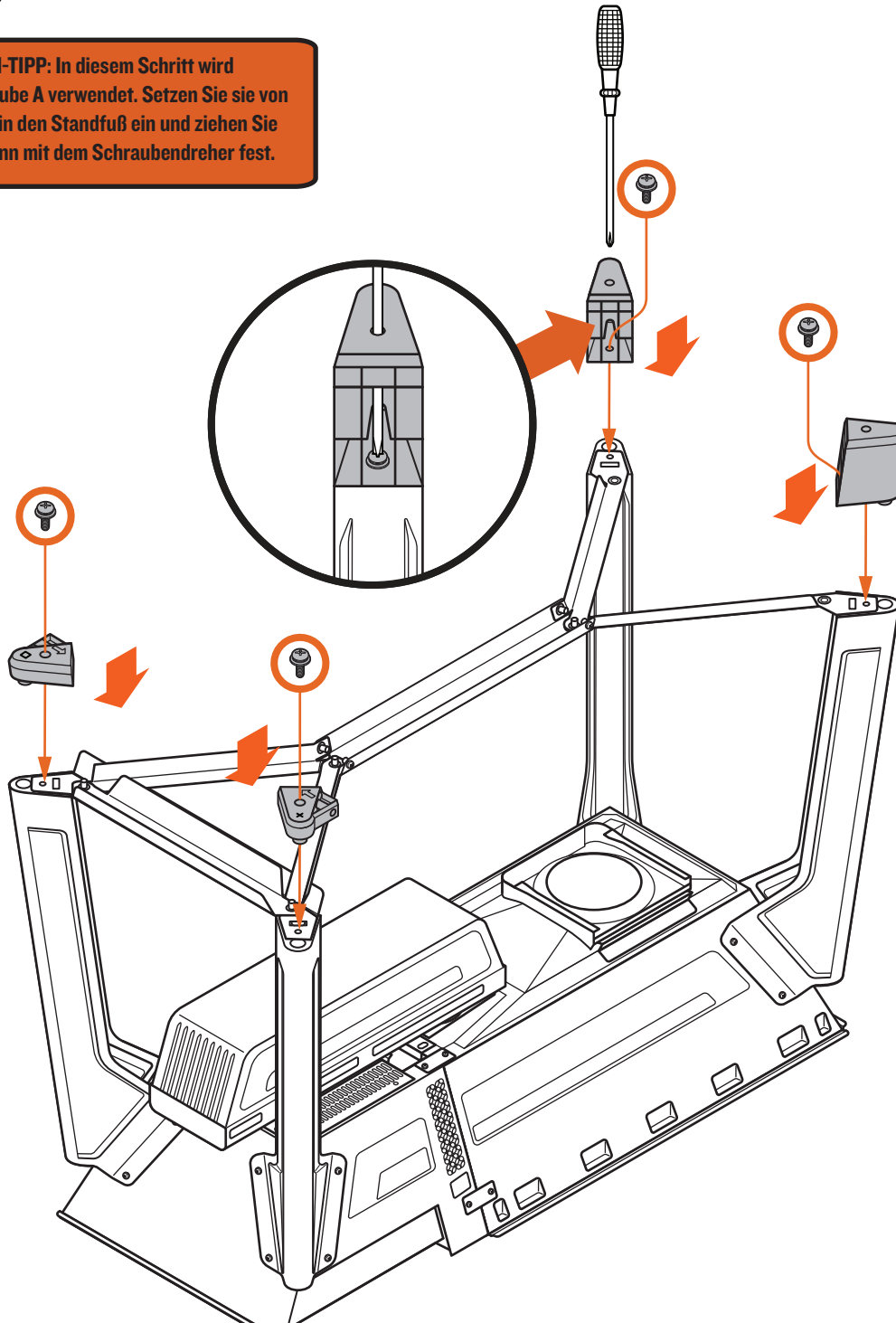

 **PROFI-TIPP:** In diesem Schritt wird Schraube A verwendet. Setzen Sie sie von Hand in den Standfuß ein und ziehen Sie sie dann mit dem Schraubendreher fest.



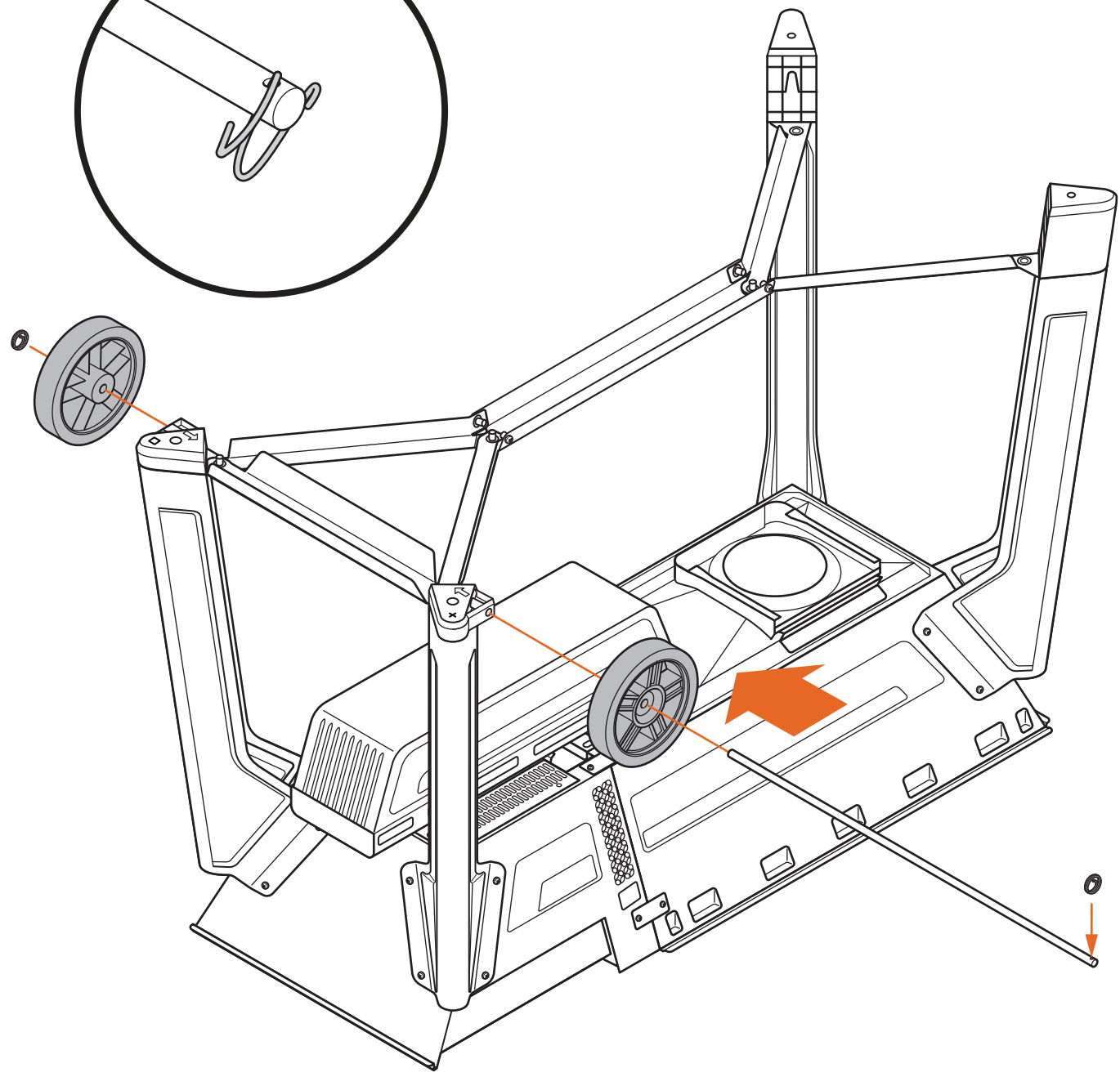
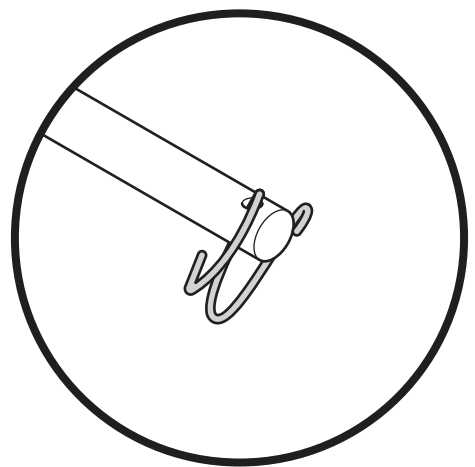
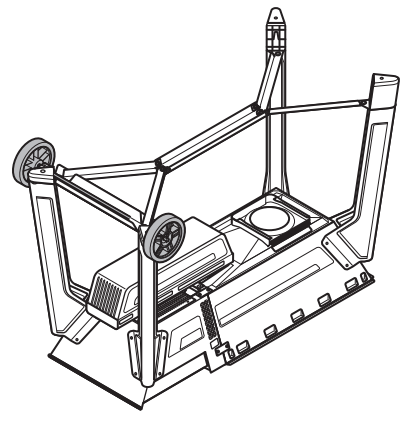
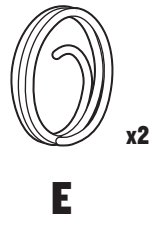

4 RÄDER MONTIEREN





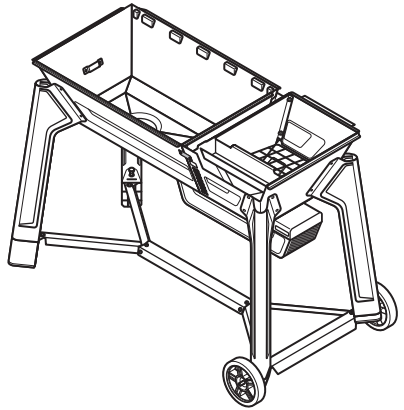
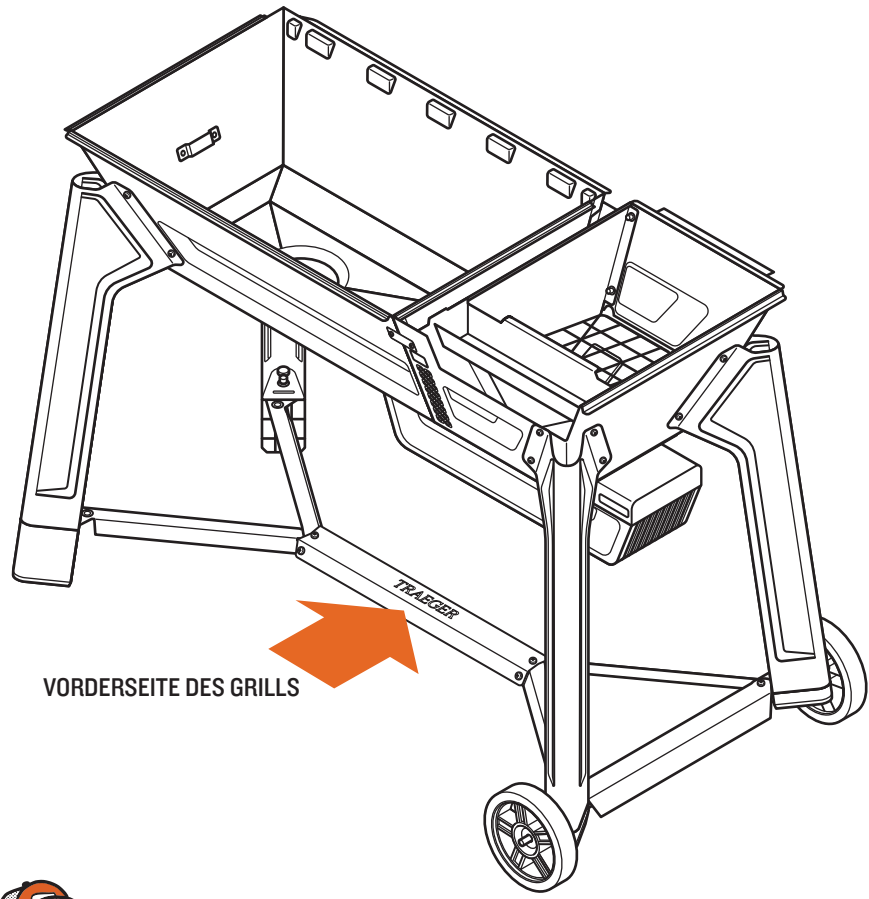
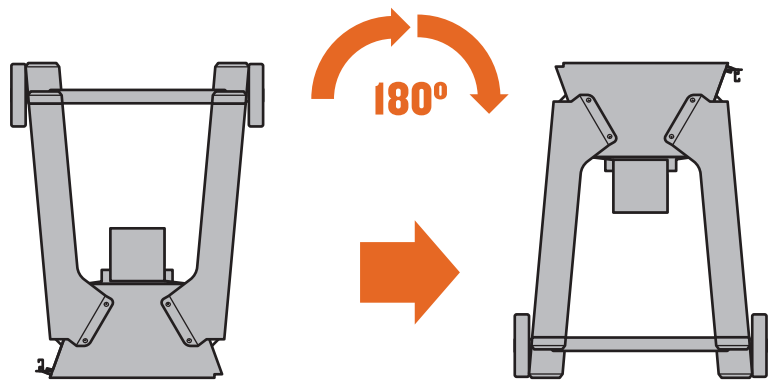

PROFI-TIPP: Lassen Sie sich beim Anheben und Drehen des Grills von einer zweiten Person helfen.

5 GRILL AUFRECHT DREHEN

**GUTE ARBEIT!
KAPITEL 2 ABGESCHLOSSEN!**

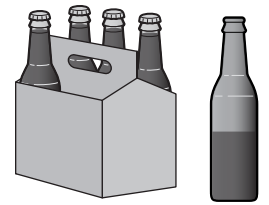

KAPITEL 3

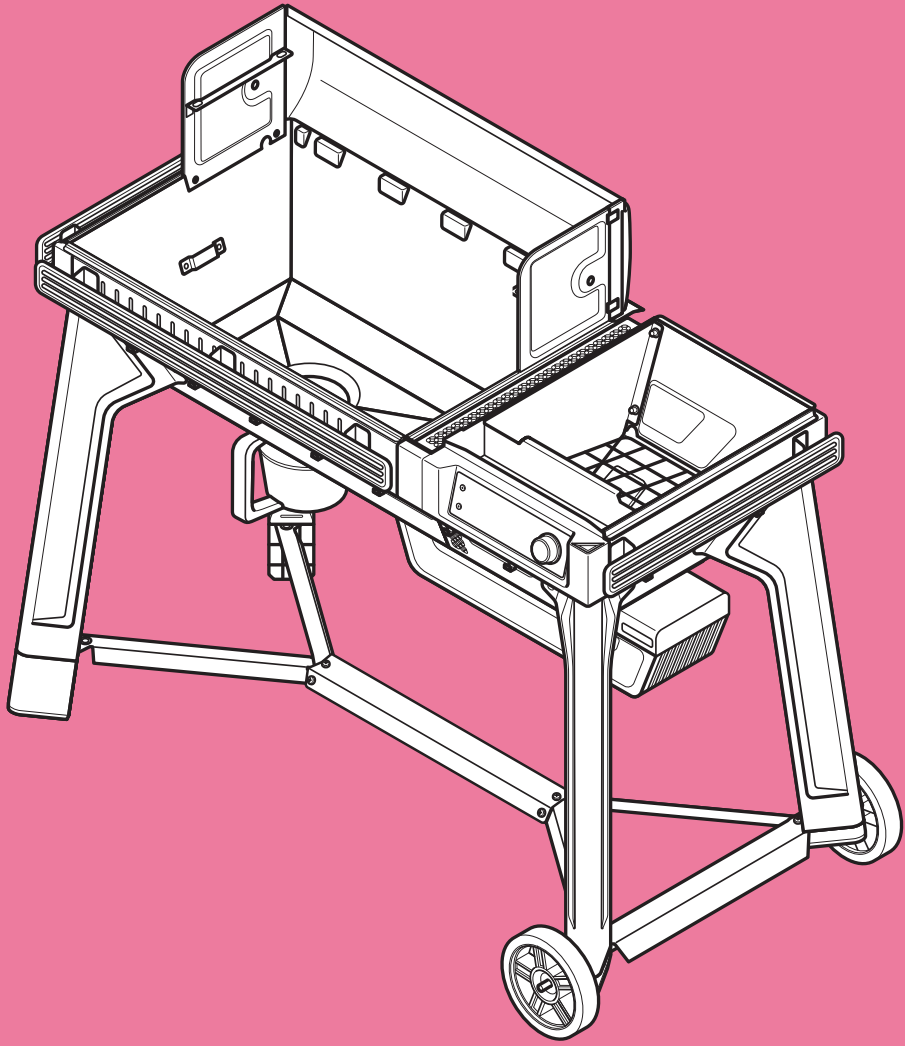

BEDIENELEMENTE UND ABLAGEN

KAPITEL 3

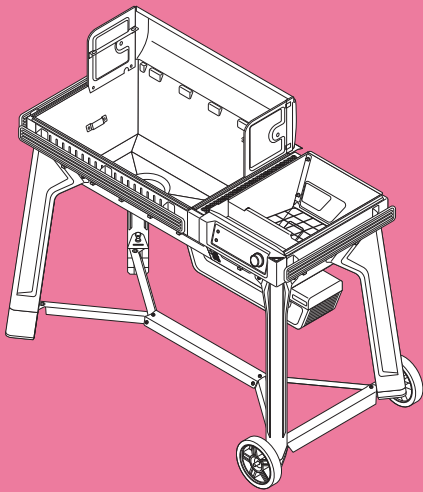

1 P.A.L.-SCHIENEN ZUSAMMENBAUEN

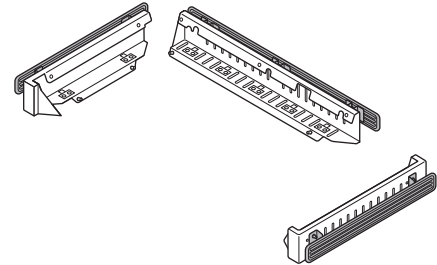
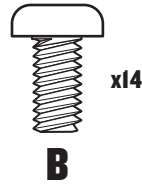
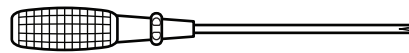

PROFI-TIPP: Ziehen Sie alle Schrauben zunächst handfest an und ziehen Sie sie dann mit einem Schraubendreher fest.

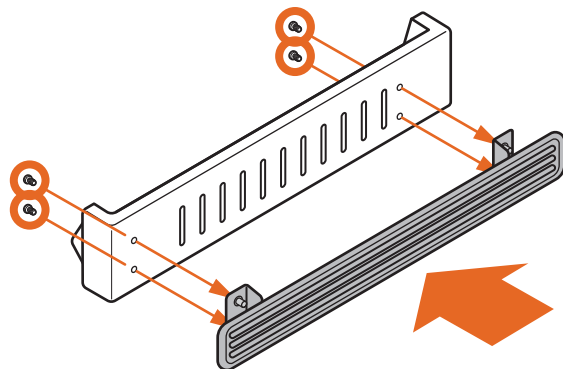
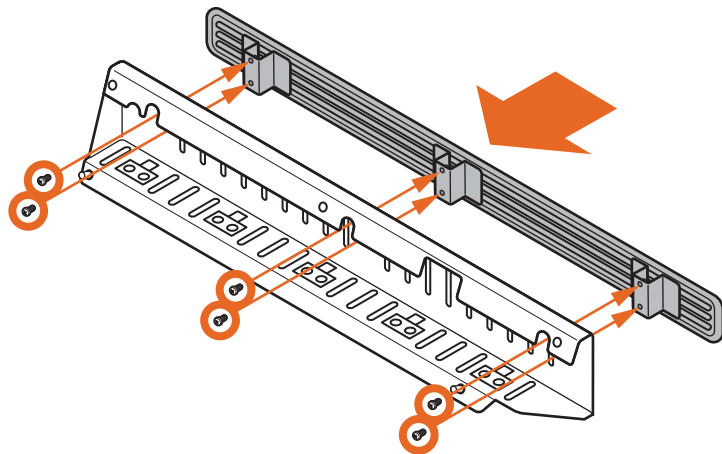
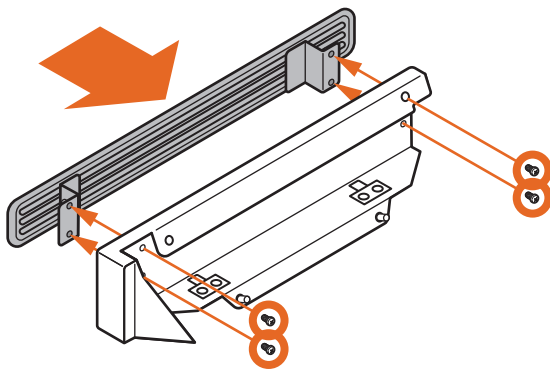



PROFI-TIPP: Dieser Schritt kann ein bisschen schwierig sein. Scannen Sie den QR-Code, um ein Video mit einer Animation zur Montage anzuzeigen. Gehen Sie für ein Video zu Kapitel 3, Schritt 2.



PROFI-TIPP: Um zu verhindern, dass Befestigungsteile in das Förderschneckengehäuse fallen, legen Sie dieses Handbuch auf den Rost.

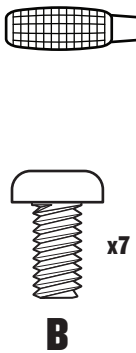
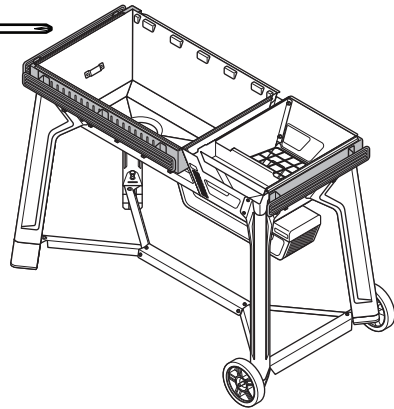
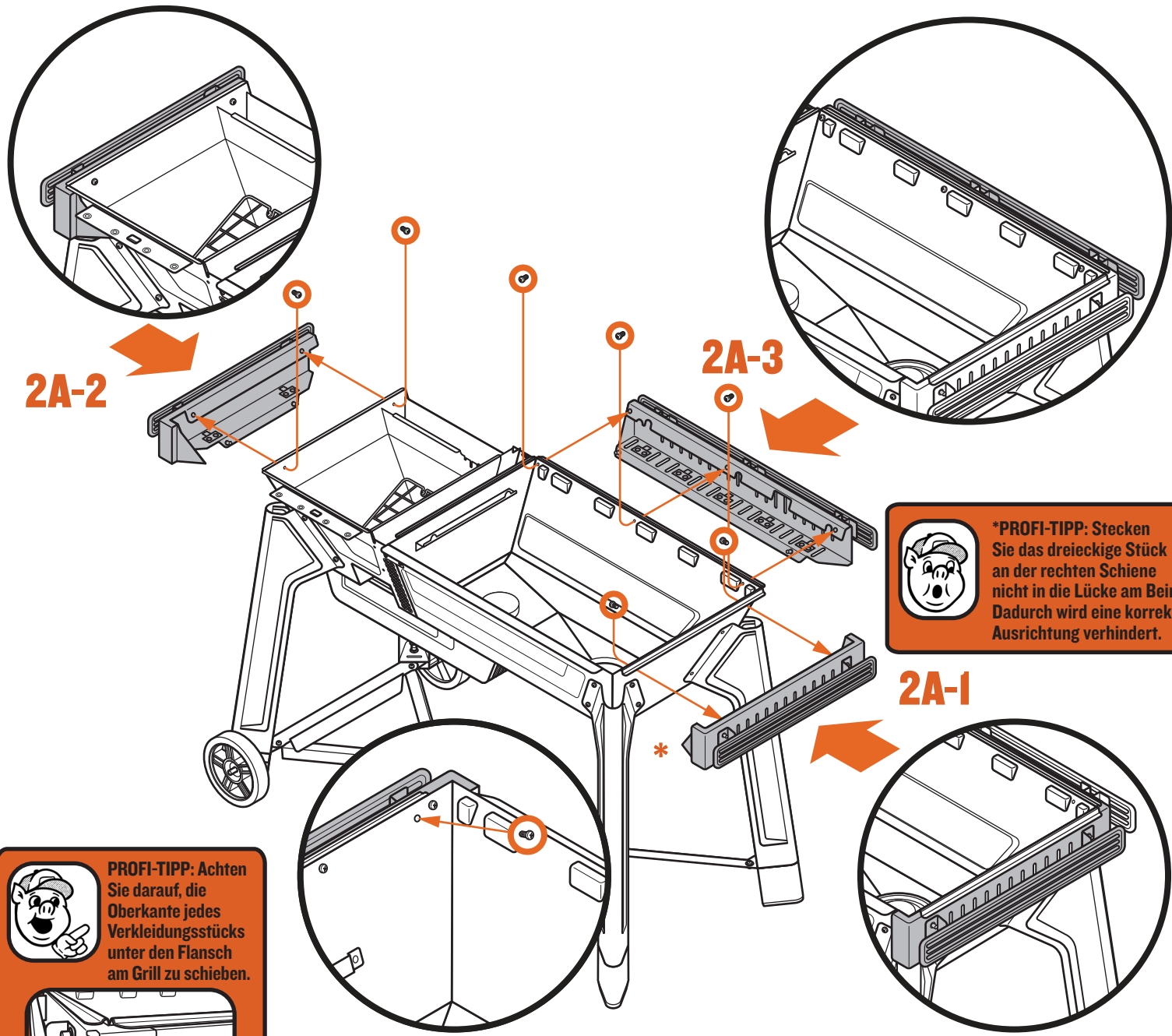

2A P.A.L.-VERKLEIDUNGEN ANBRINGEN

***PROFI-TIPP:** Stecken Sie das dreieckige Stück an der rechten Schiene nicht in die Lücke am Bein. Dadurch wird eine korrekte Ausrichtung verhindert.





PROFI-TIPP: Achten Sie darauf, die Oberkante jedes Verkleidungsstücks unter den Flansch am Grill zu schieben.





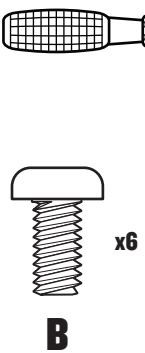

2B P.A.L.-VERKLEIDUNG BEFESTIGEN

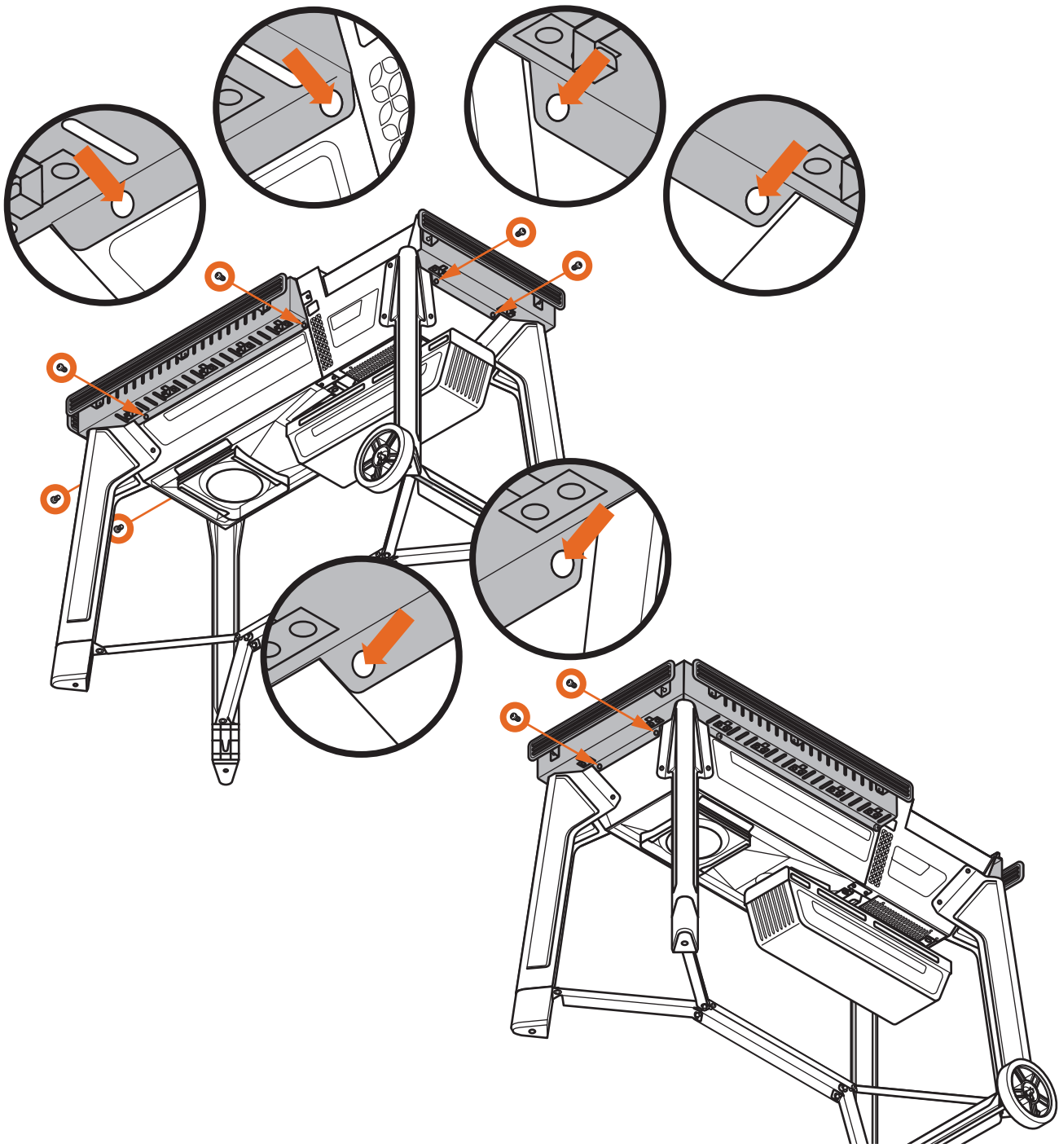
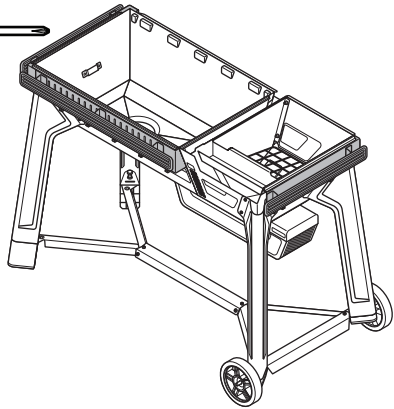

x6

B





 **PROFI-TIPP:** Für diesen Schritt sind keine Befestigungsteile erforderlich.

3 RÜCKWAND MONTIEREN

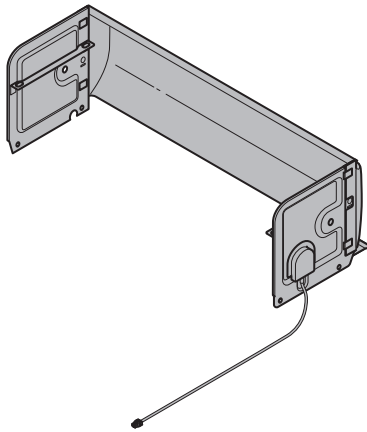
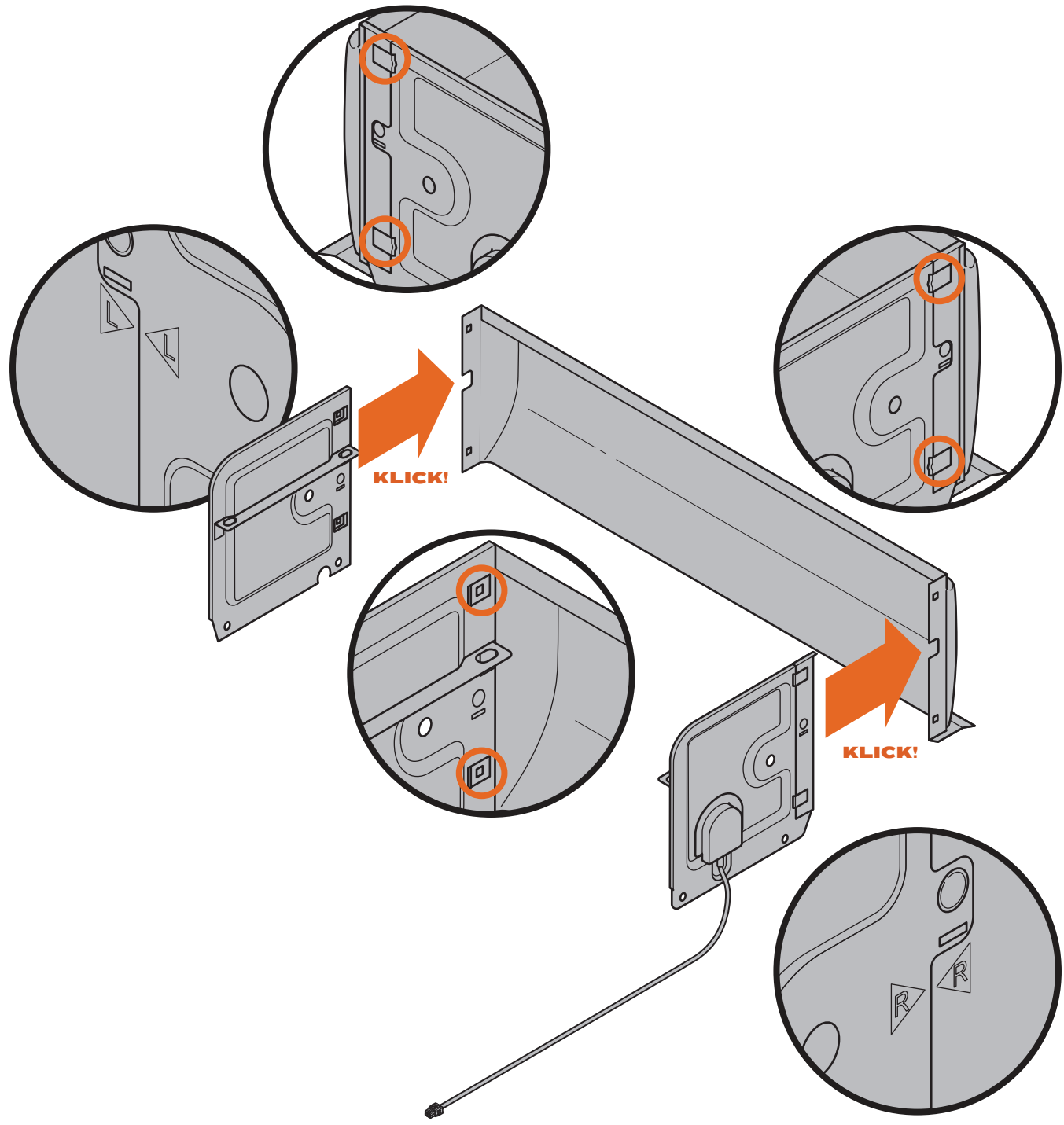

PROFI-TIPP: Achten Sie darauf, dass das Kabel nicht zwischen Rückwand und Grillgehäuse eingeklemmt wird! Führen Sie das Kabel außerdem vorsichtig durch die Öffnungen, um Beschädigungen zu vermeiden!

4 RÜCKWANDKABEL VERLEGEN

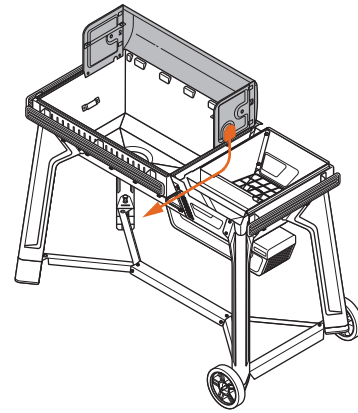

4A

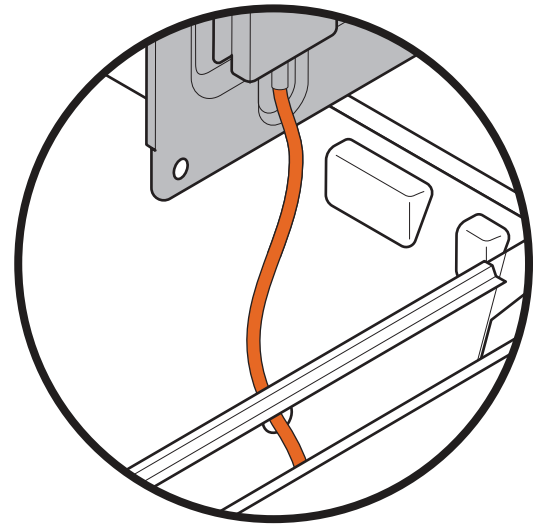
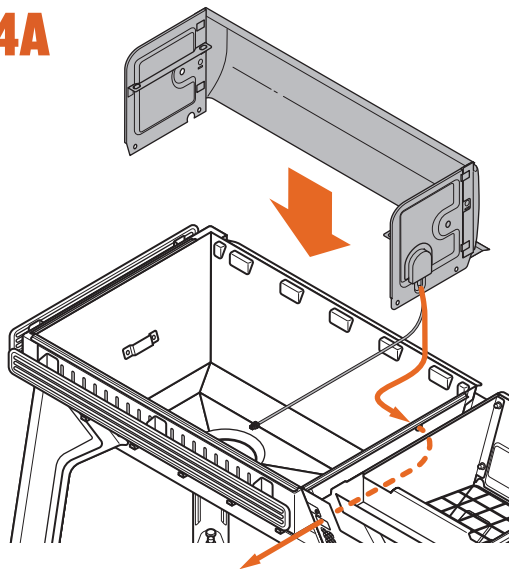

4B

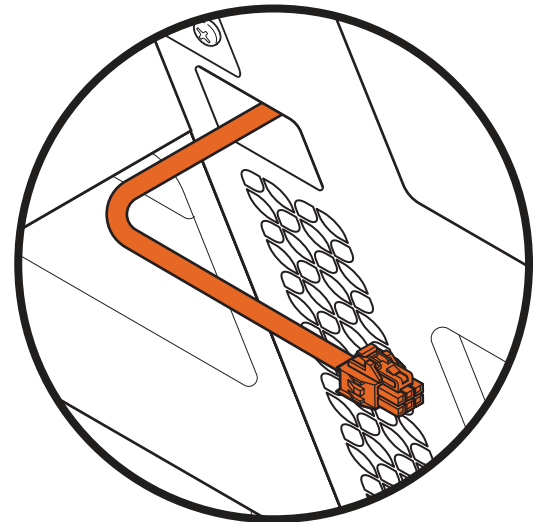
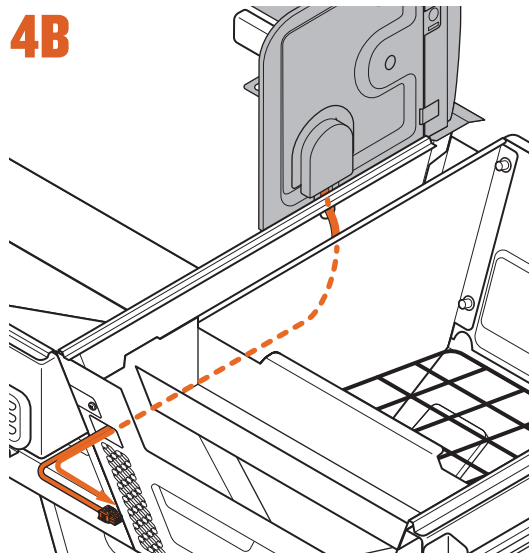



5 RÜCKWAND ANBRINGEN

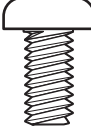
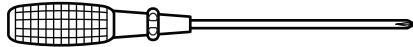

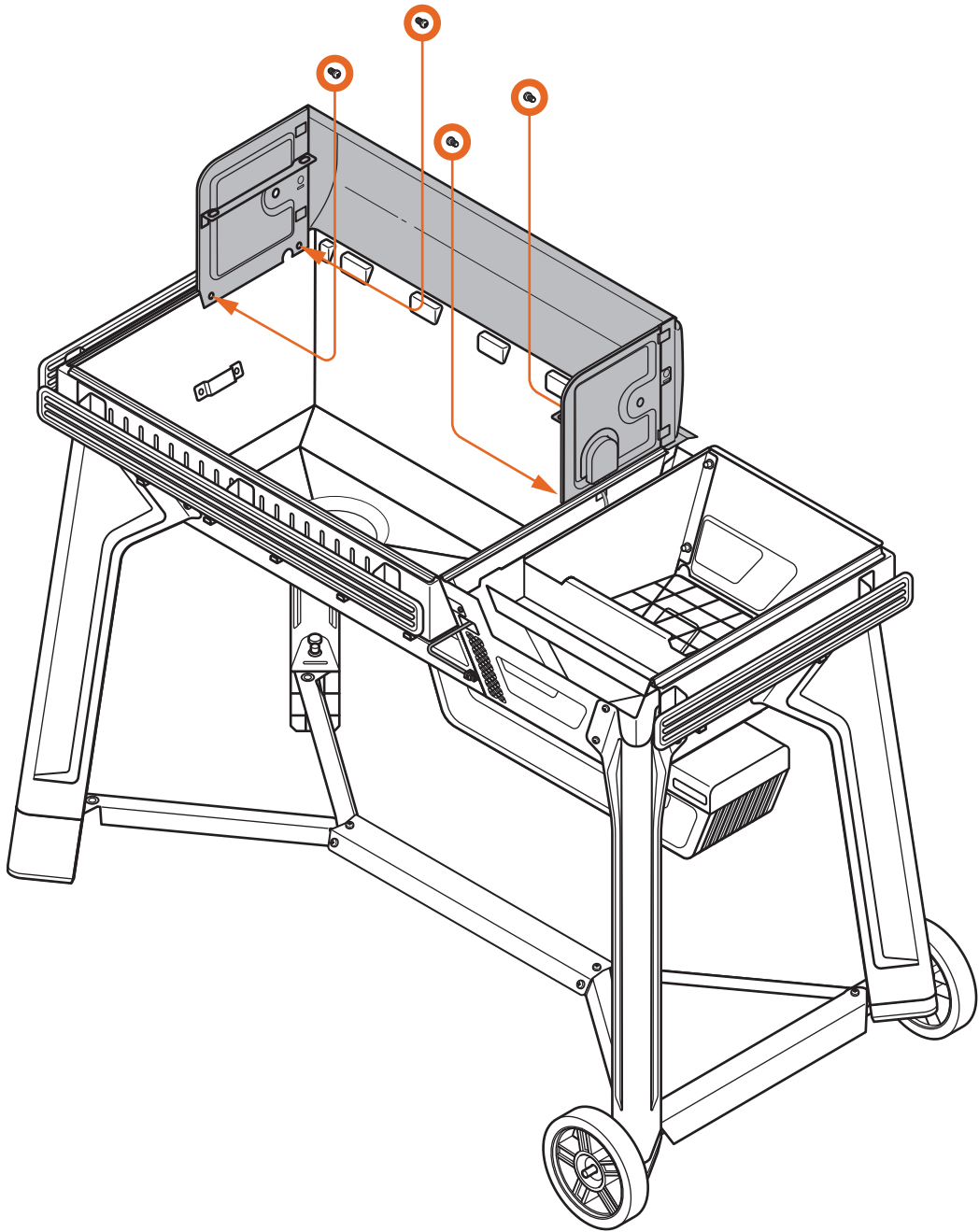
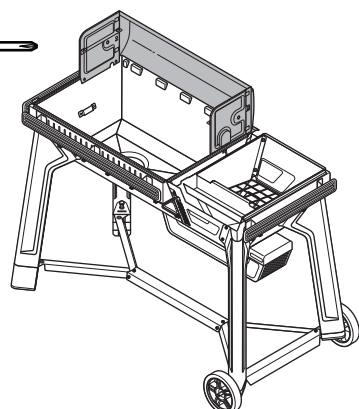

B x4



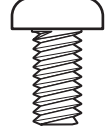
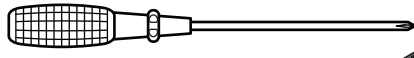

6 RÜCKSEITIGE HAKENLEISTE BEFESTIGEN



x2

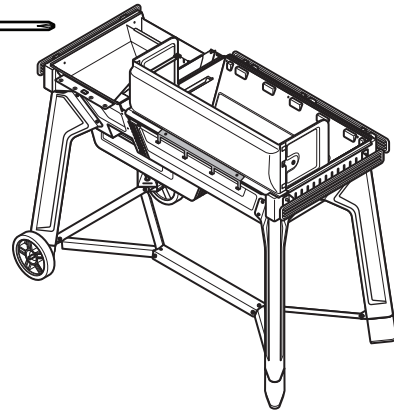
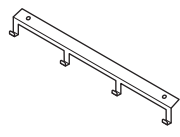

B

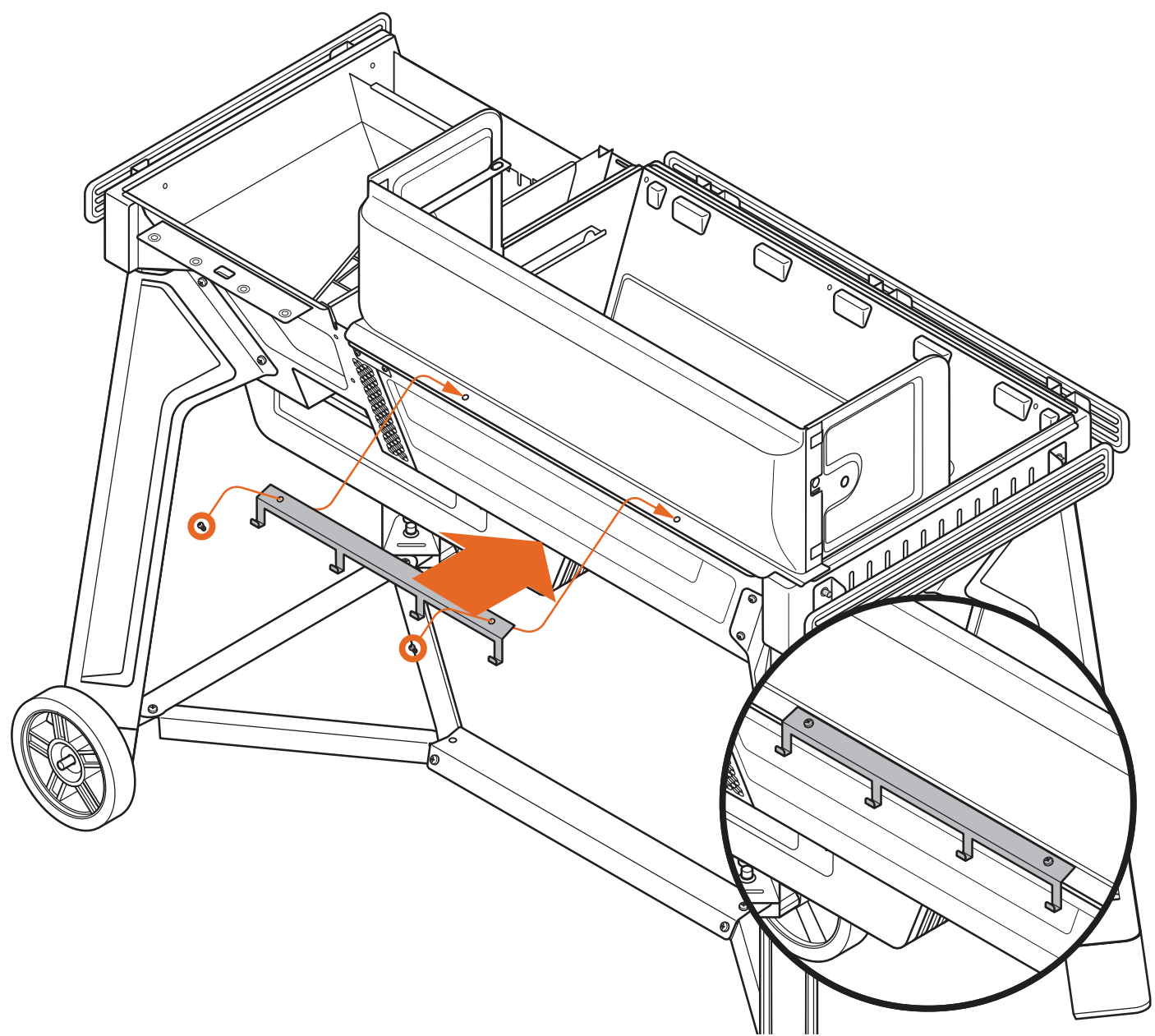



7 BEDIENFELD ANSCHLIESSEN



14-POLIGER
STECKER DES
BEDIENFELDS

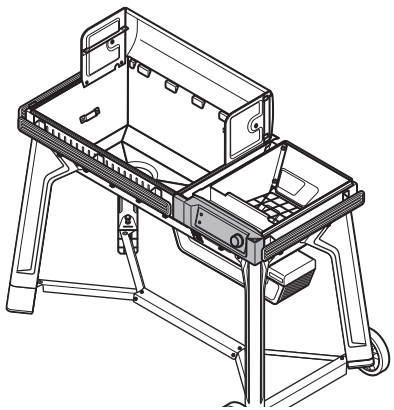
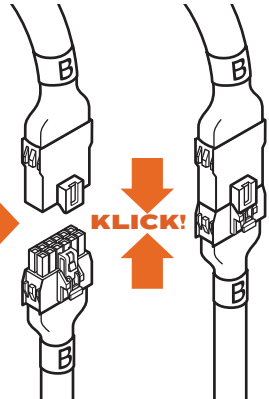
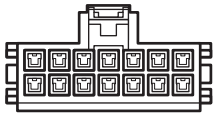

PROFI-TIPP: Zum einfacheren Anschließen legen Sie das Bedienfeld mit der Rückseite nach unten auf den Rand der Pelletkammer.

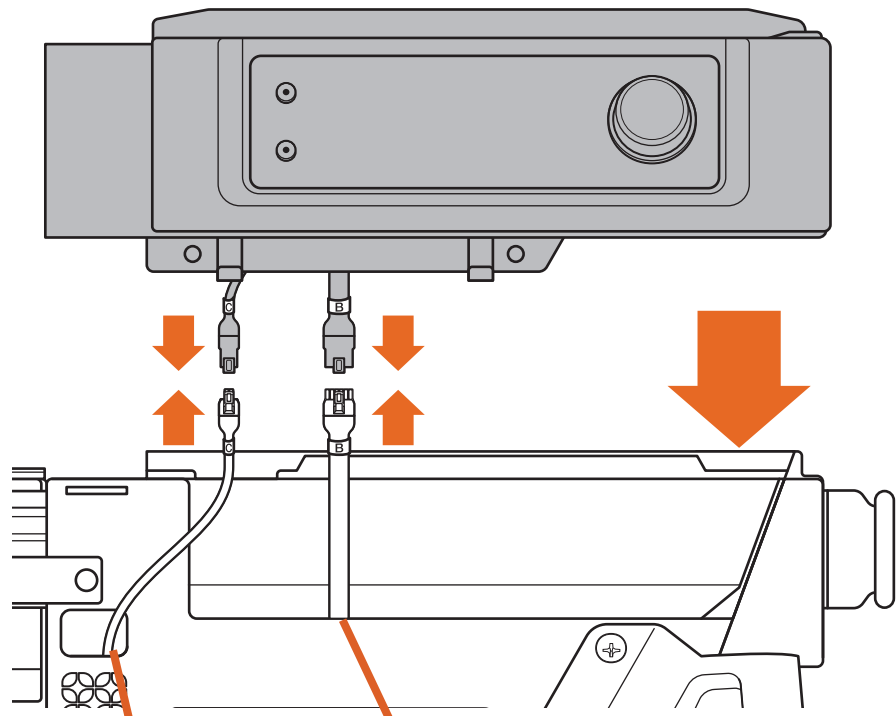
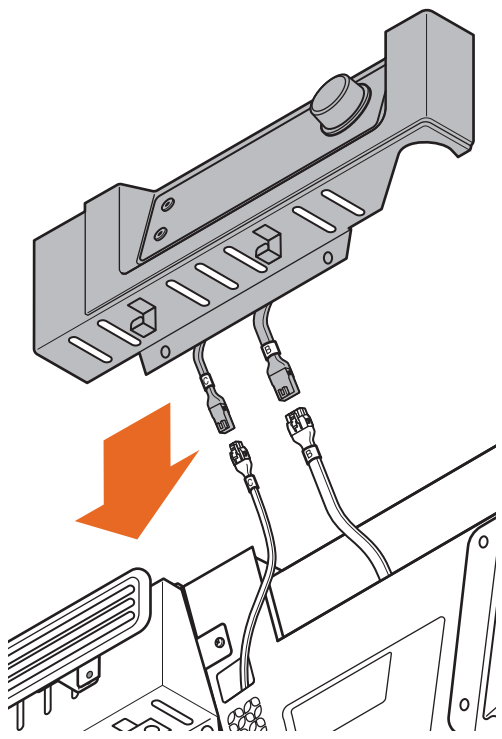

PROFI-TIPP: Stecken Sie die Kabel nach dem Anschließen wieder in den Grill, um ein Einklemmen zu verhindern.

4-POLIGER STECKER DES TEMPERATURSENSORS



14-POLIGER STECKER DES BEDIENFELDS

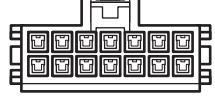

PROFI-TIPP: Um die Anbringung von Stecker B zu erleichtern, schneiden Sie den Kabelbinder durch, mit dem er am Grill befestigt ist.



 **PROFI-TIPP:** Installieren Sie das Bedienfeld über dem Flansch in der Pelletkammer.

8A BEDIENFELD ANBRINGEN

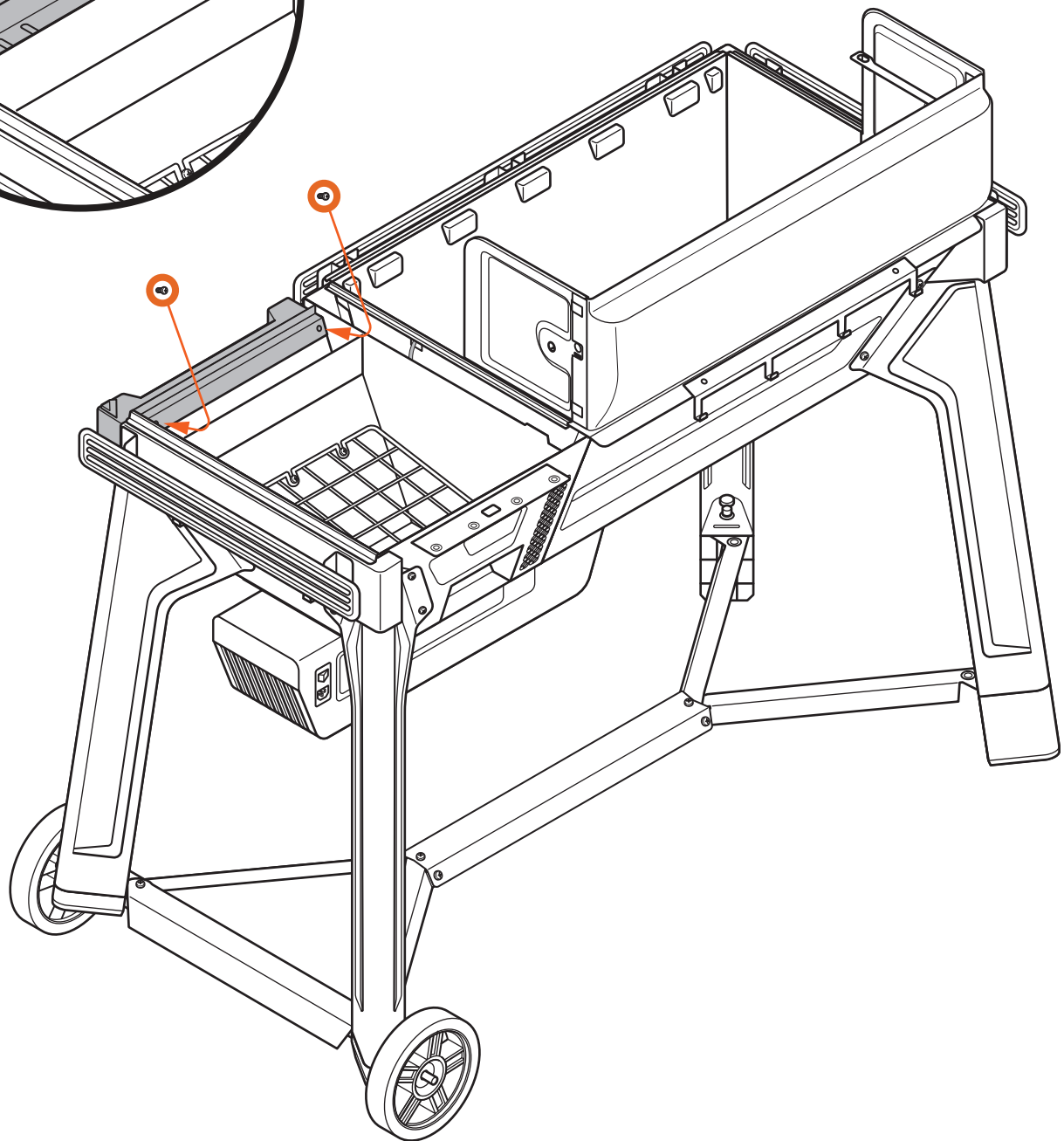
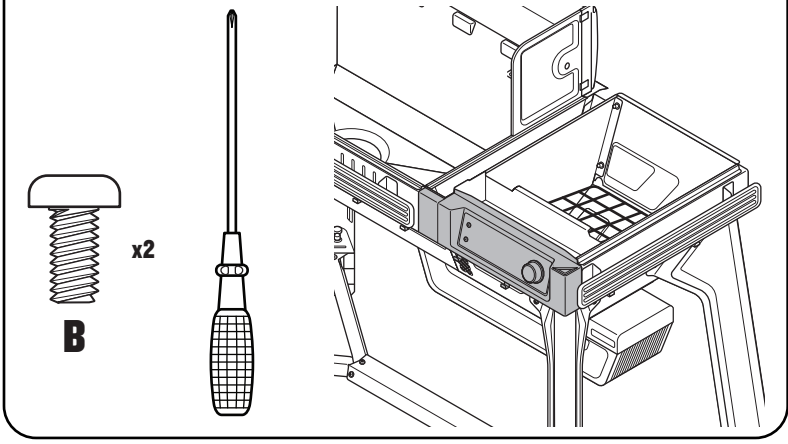
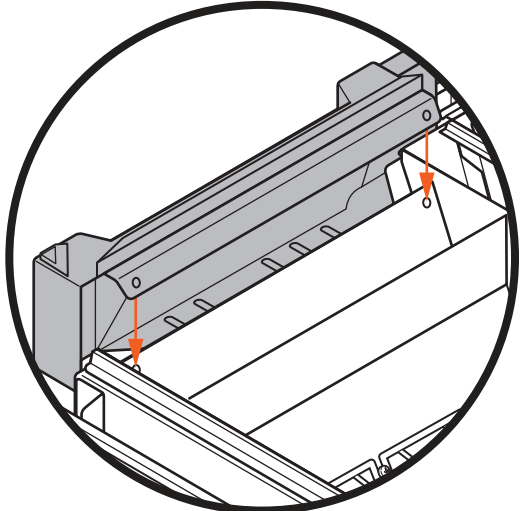



8B BEDIENFELD ANBRINGEN

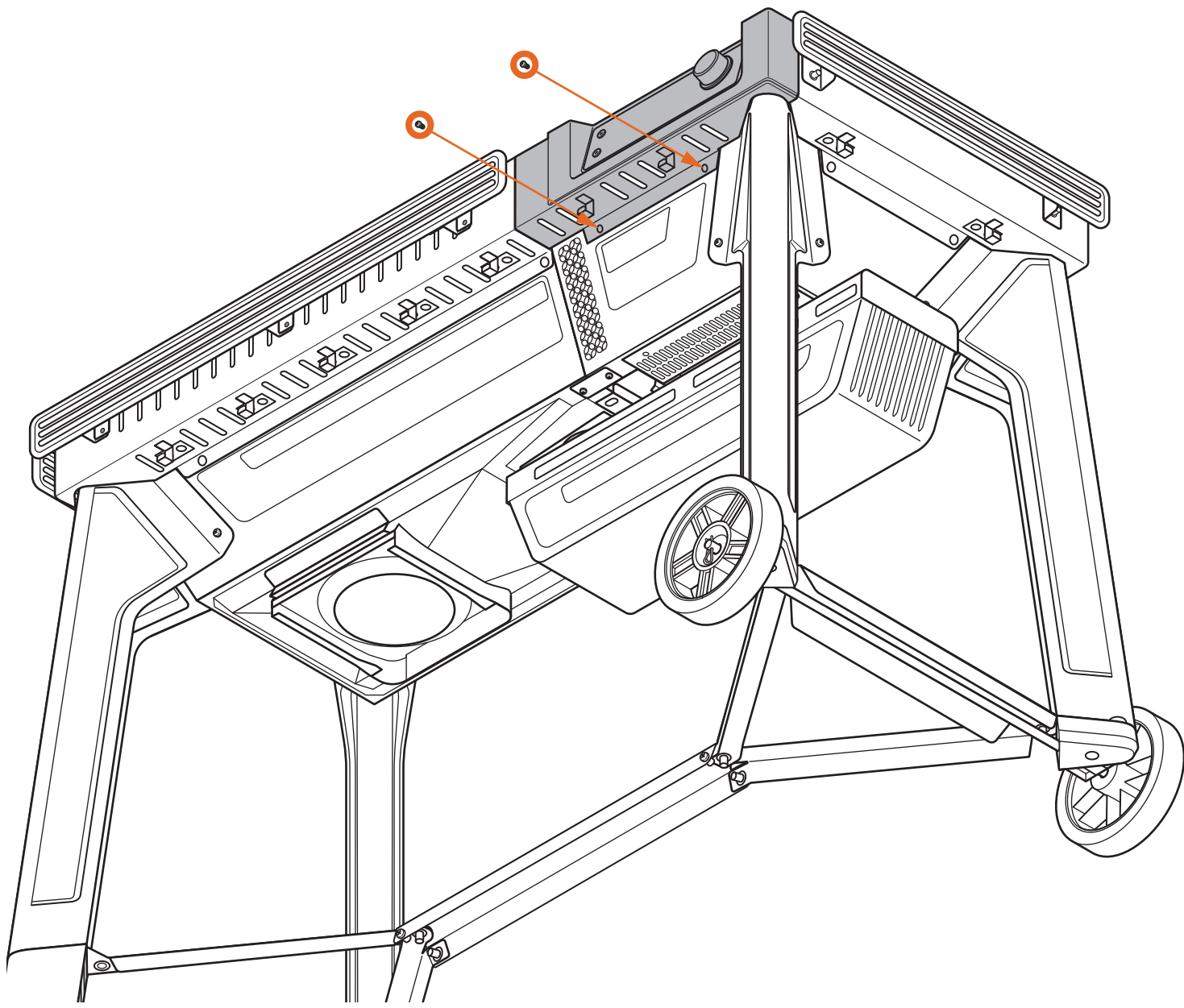
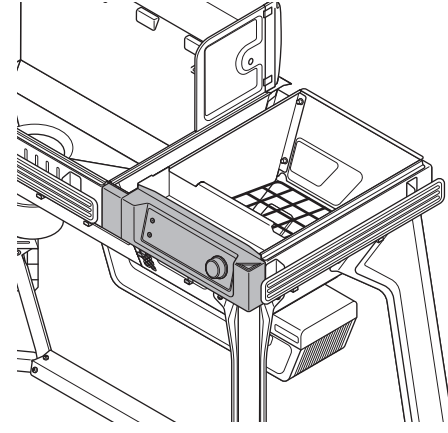
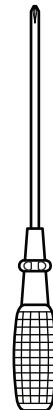
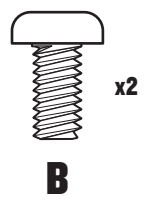



9 BELÜFTUNGSPLATTE ANBRINGEN

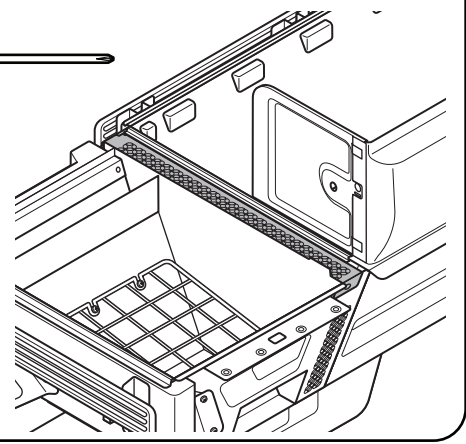
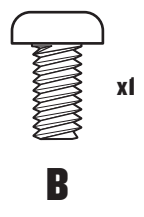
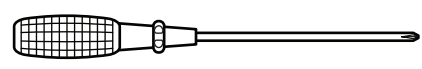

9A

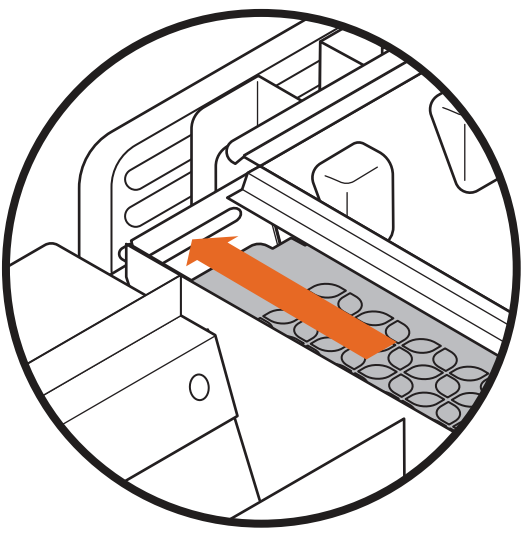

9B

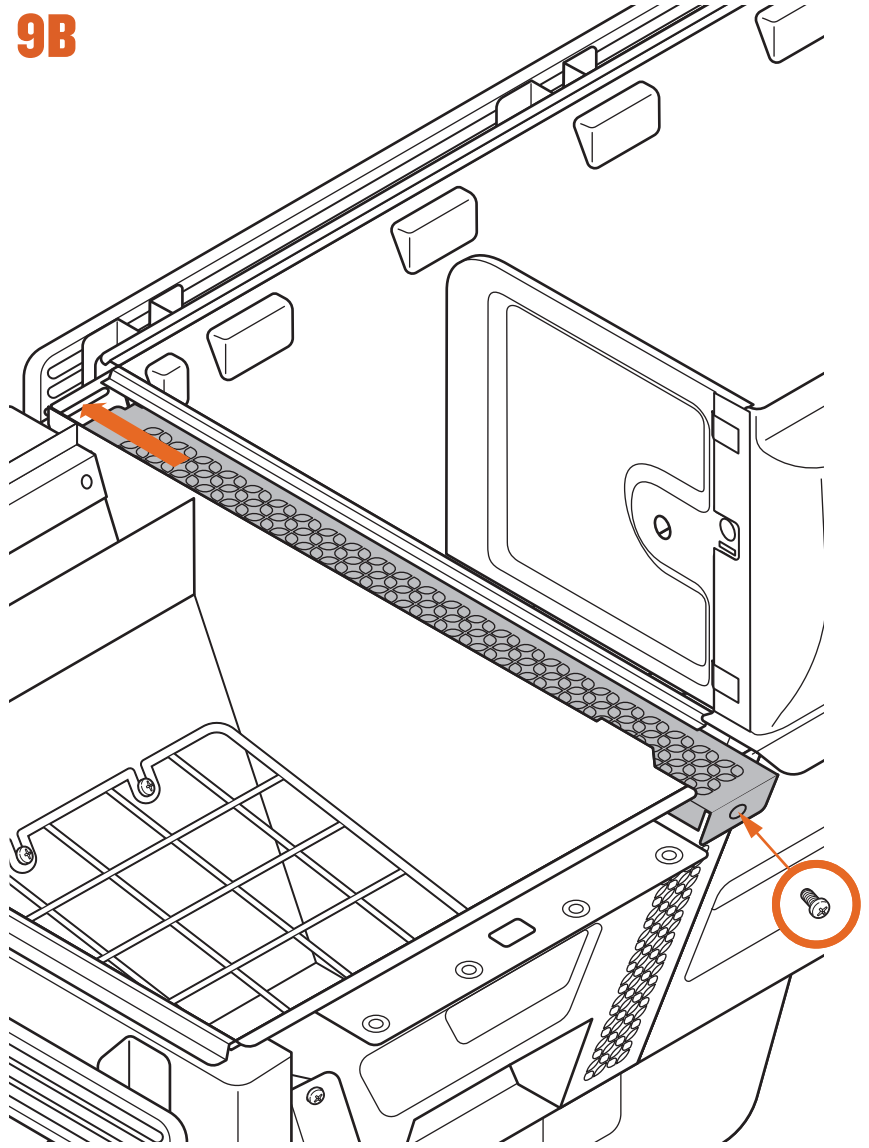

**GUTE ARBEIT!
KAPITEL 3 ABGESCHLOSSEN!**

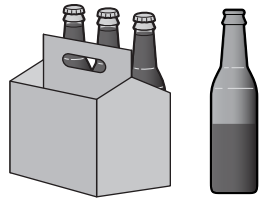

KAPITEL 4

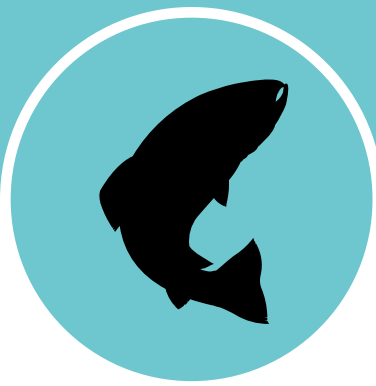
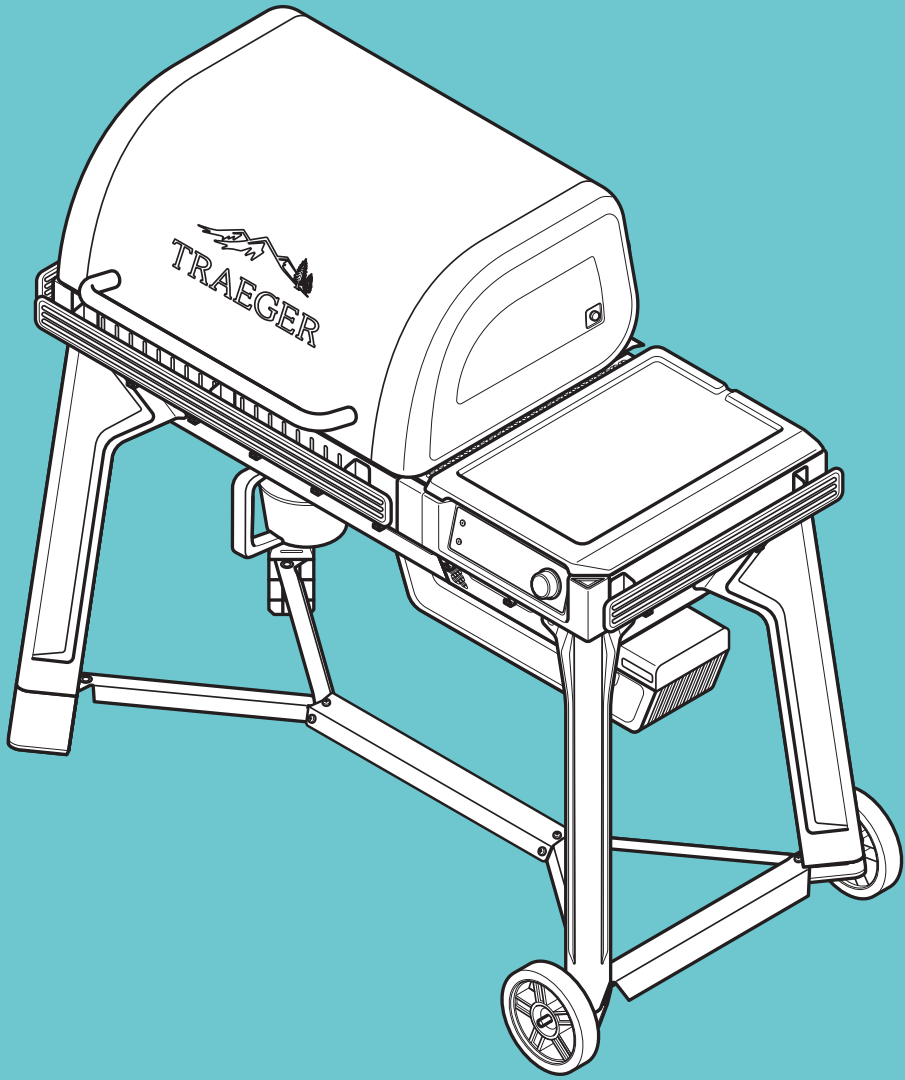

DECKEL & INNENTEILE DES GRILLS

KAPITEL 4

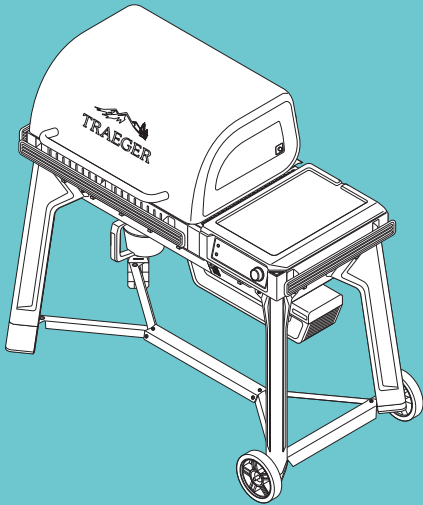

1 DECKEL DER PELLETKAMMER ANBRINGEN

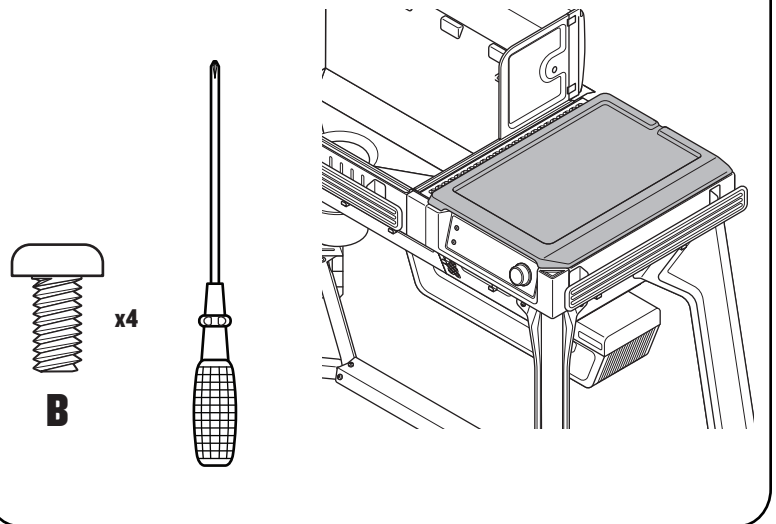

PROFI-TIPP: Ziehen Sie alle Schrauben zunächst handfest an und ziehen Sie sie dann mit einem Schraubendreher fest.

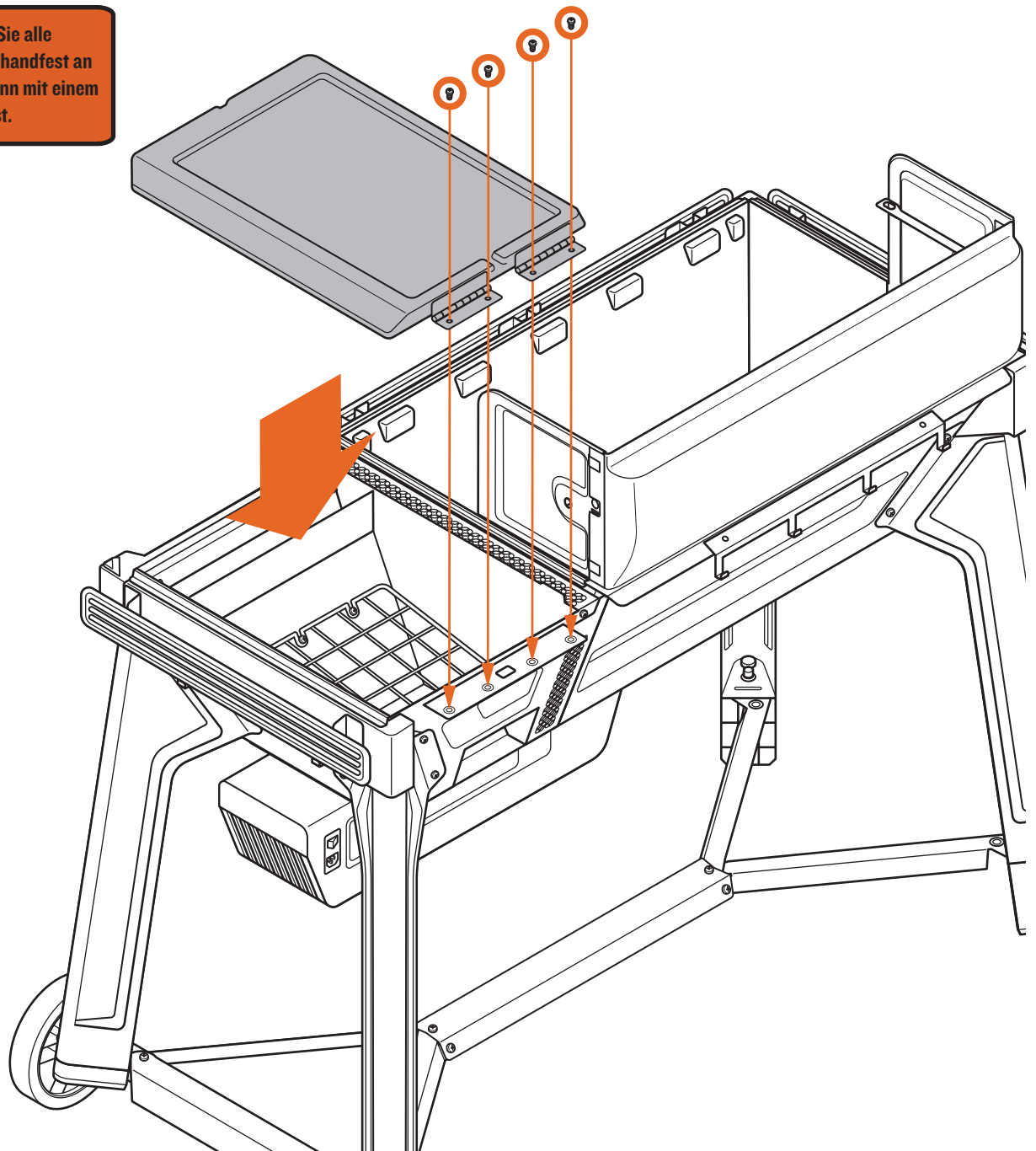



2A ABLAUFRINNE, GLUTSCHUTZ UND HITZELEITBLECH EINBAUEN

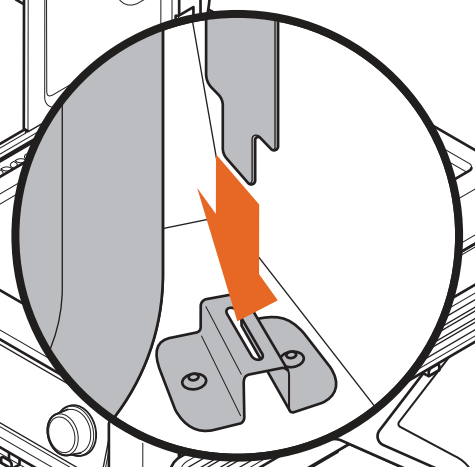
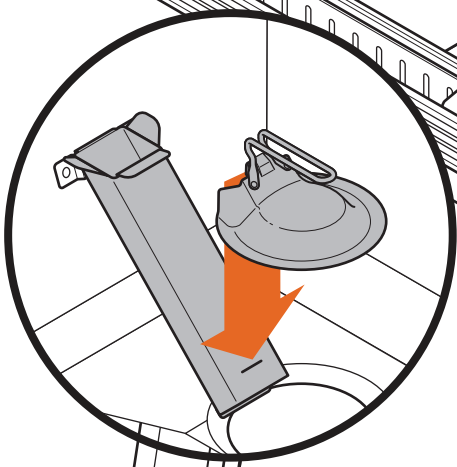
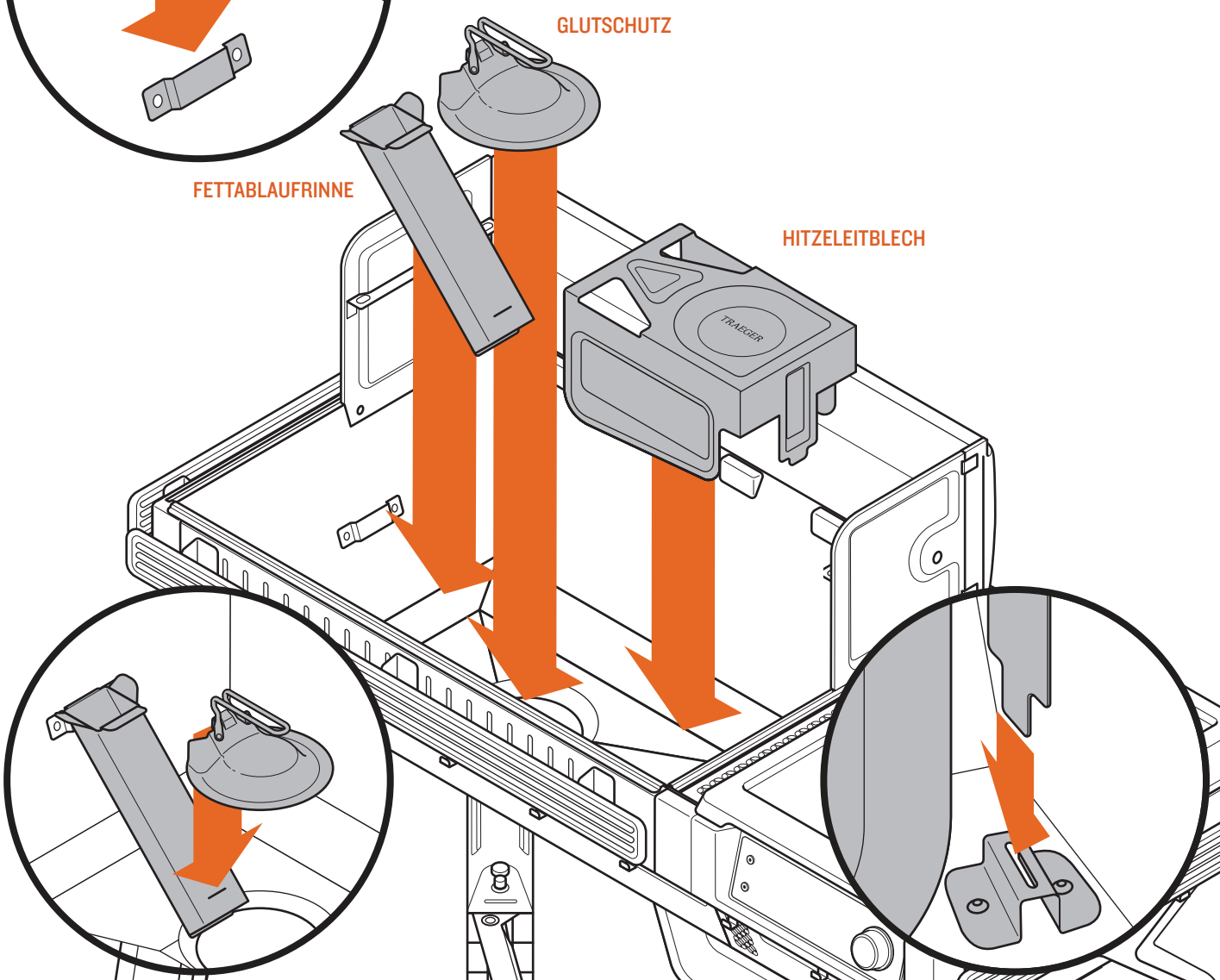
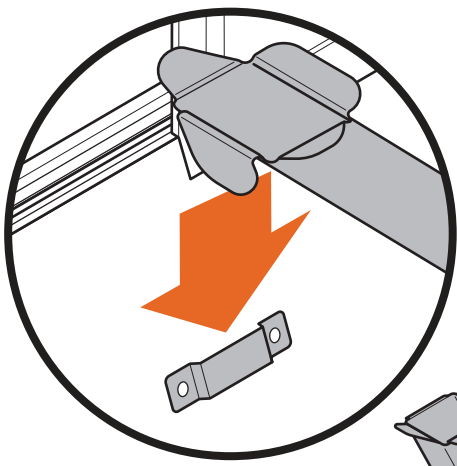
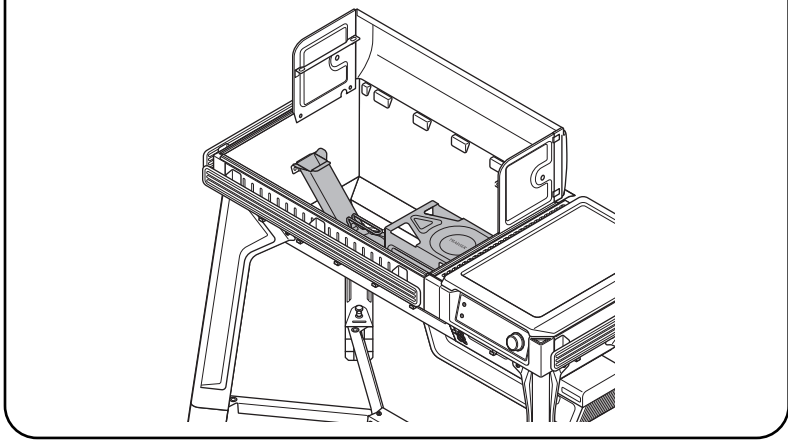
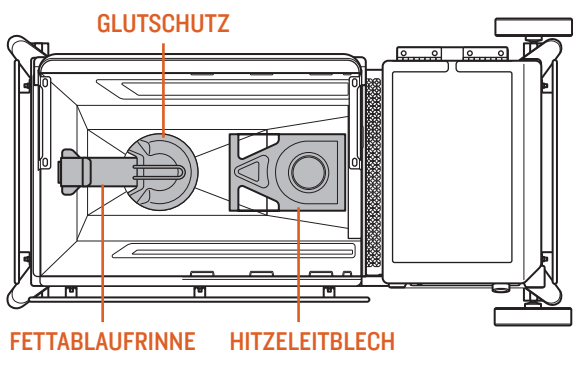



2B TROPFSCHALE EINBAUEN

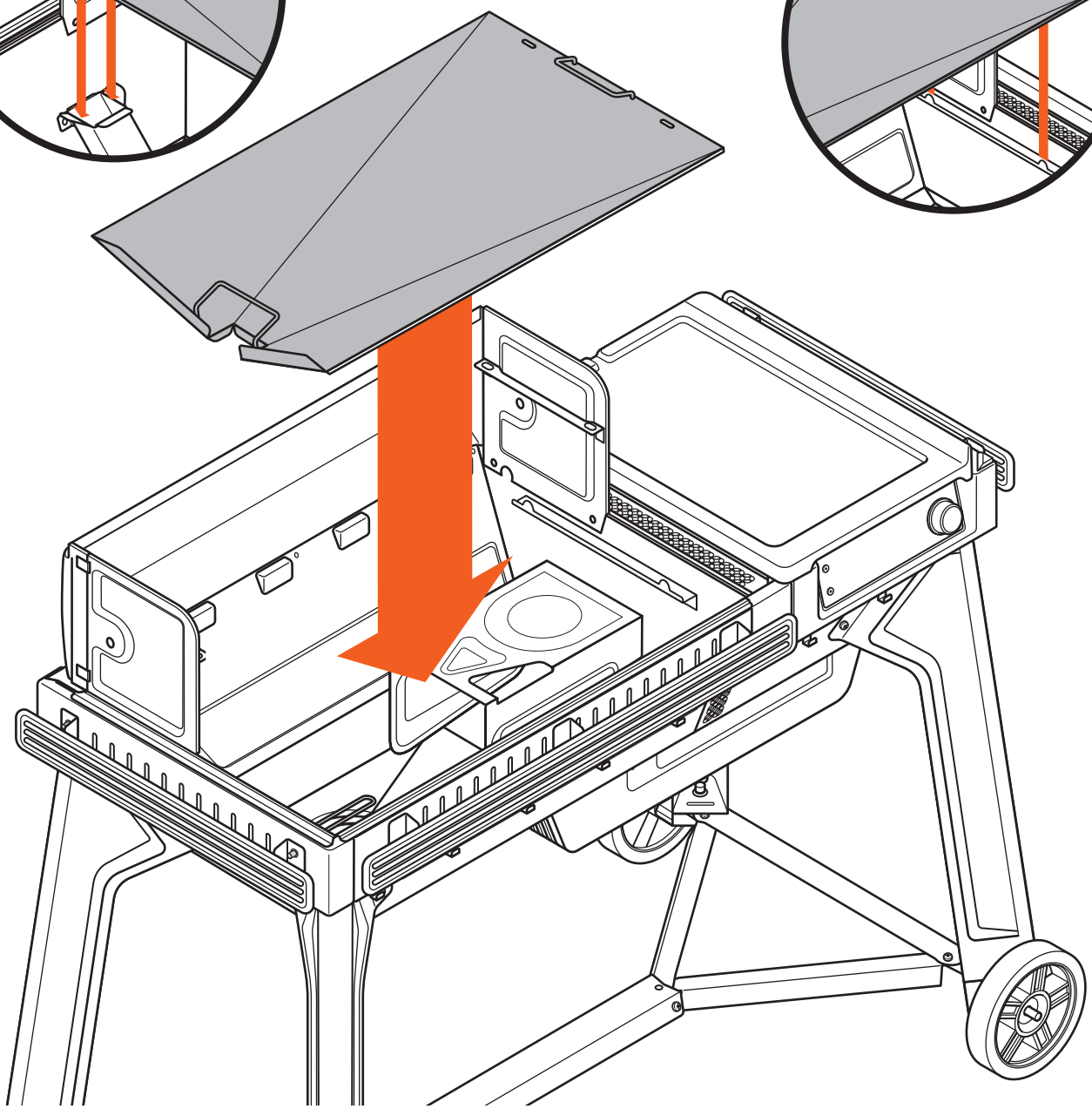
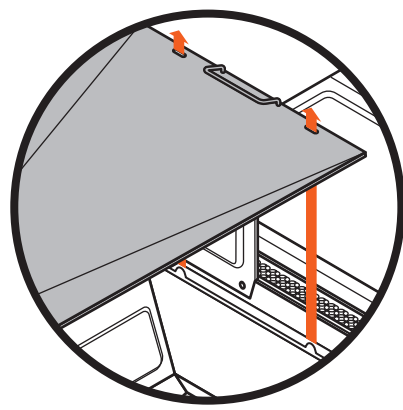
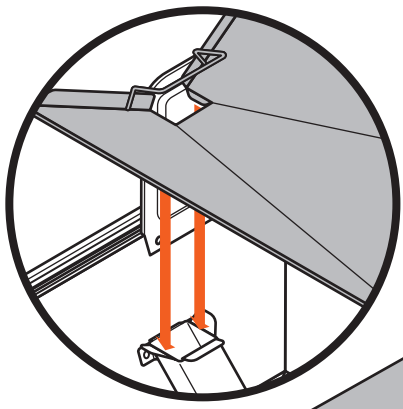
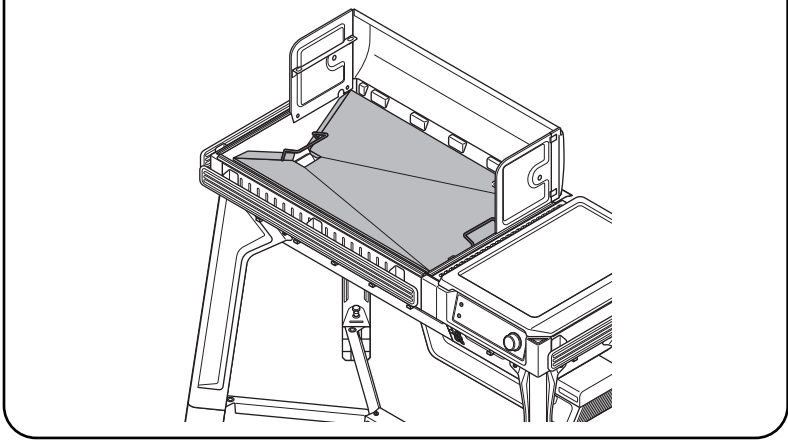



3A DECKELGRIFF ANBRINGEN

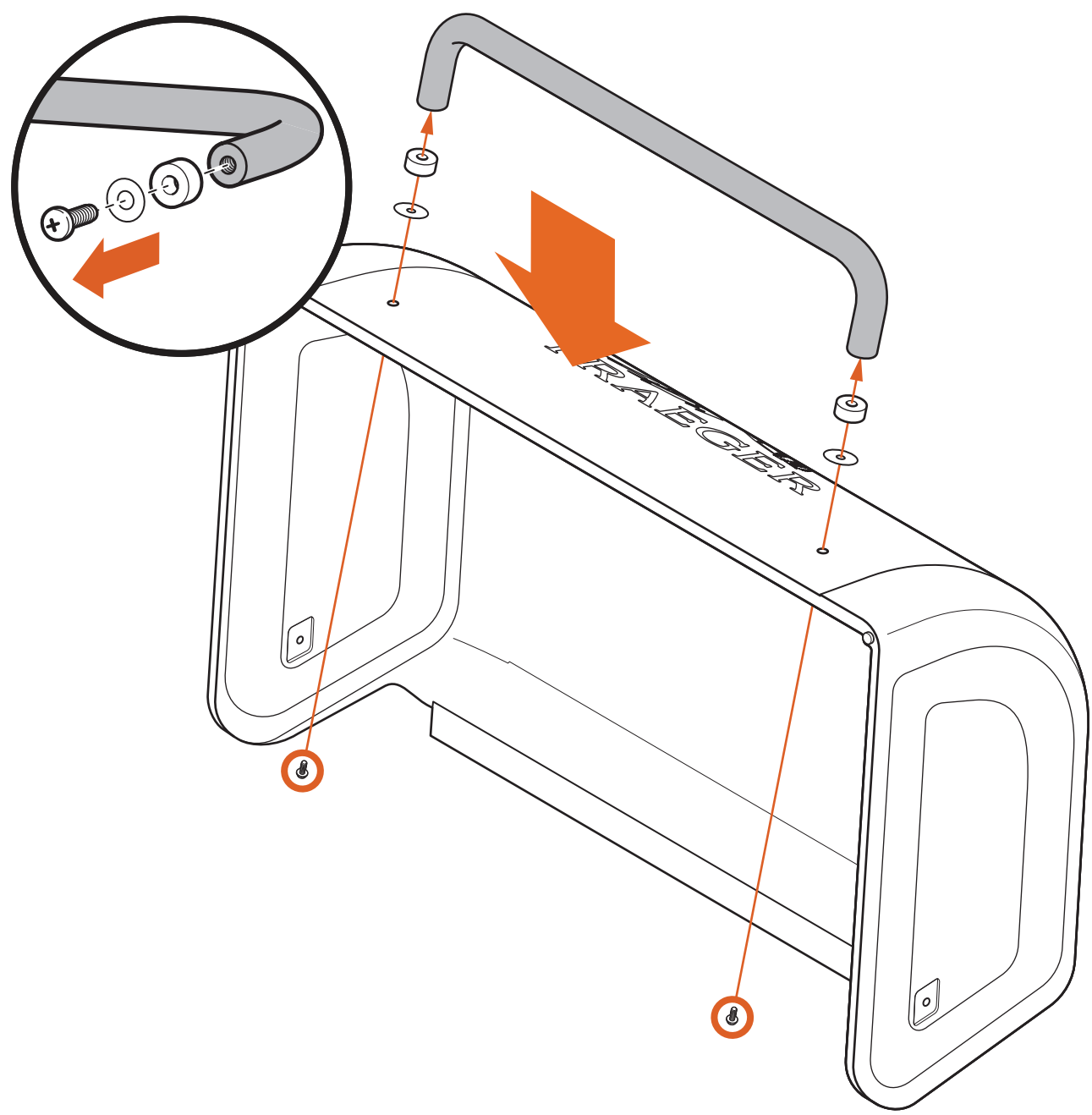
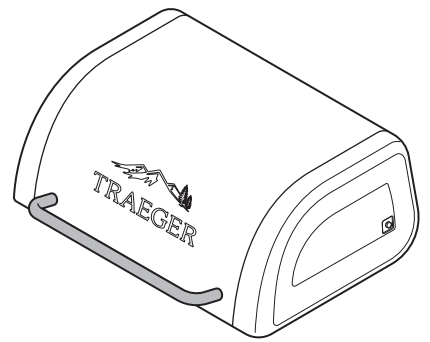
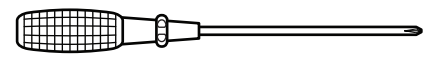



 **PROFI-TIPP:** Bringen Sie den Deckel zu zweit an.

3B DECKEL ANBRINGEN

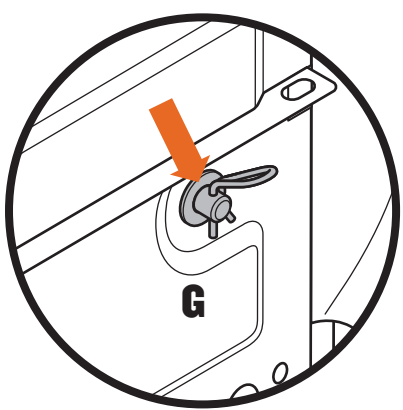
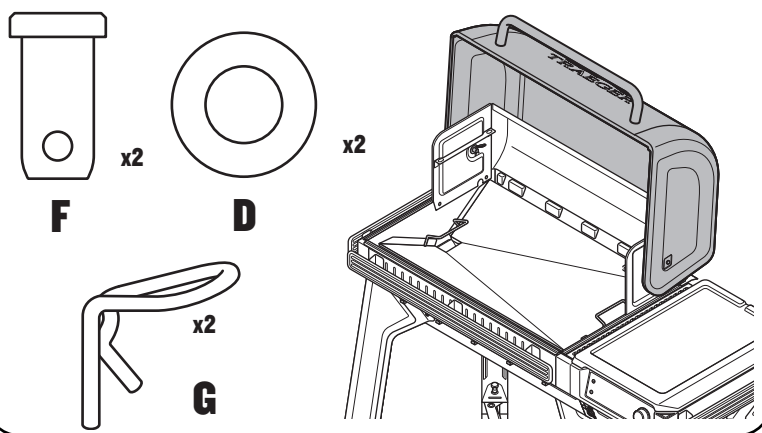

 **PROFI-TIPP:** Befestigen Sie die Splintbolzen F bei geschlossenem Deckel und öffnen Sie dann den Deckel, um G und D einzubauen.

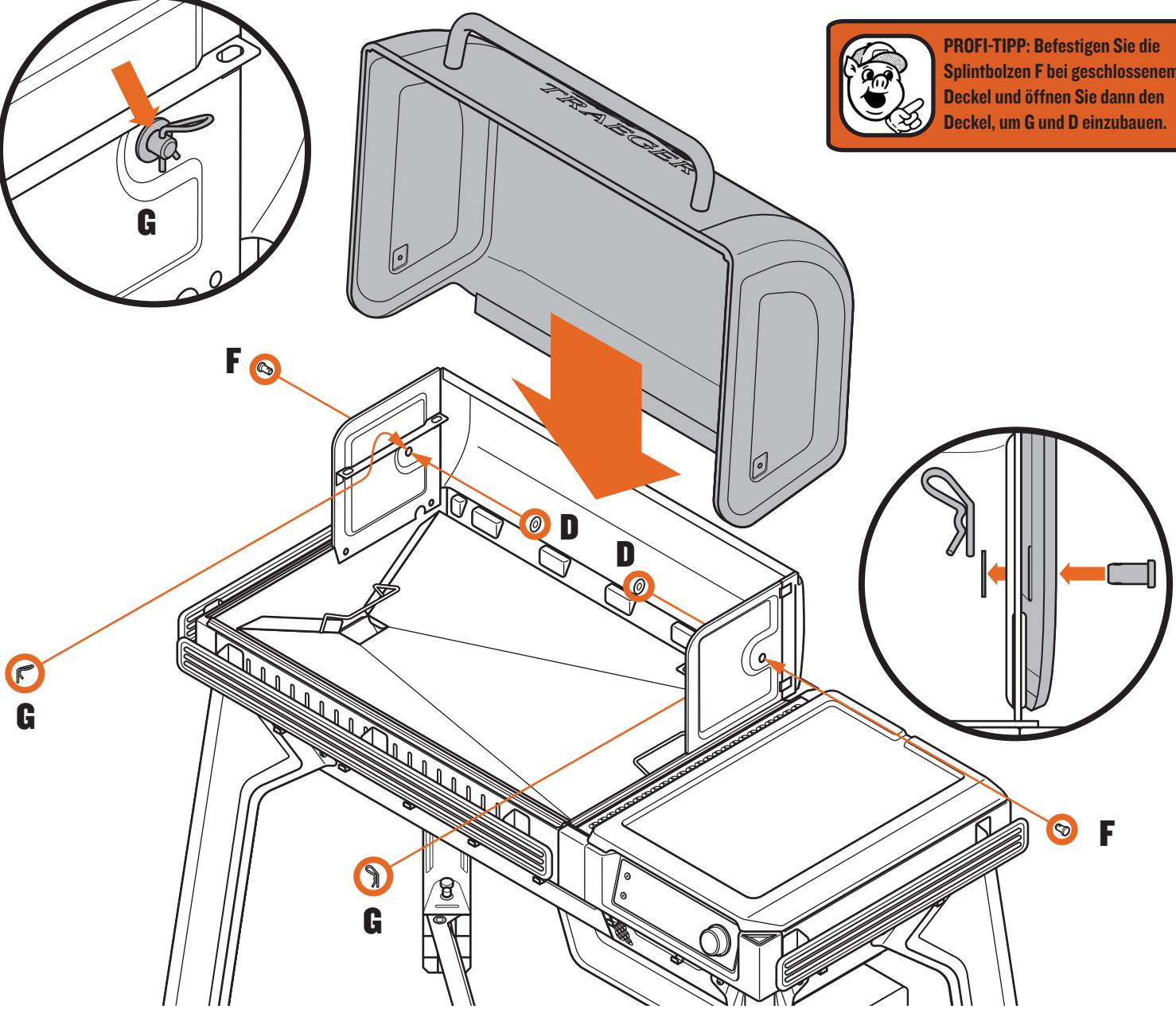



4 ROSTE EINBAUEN

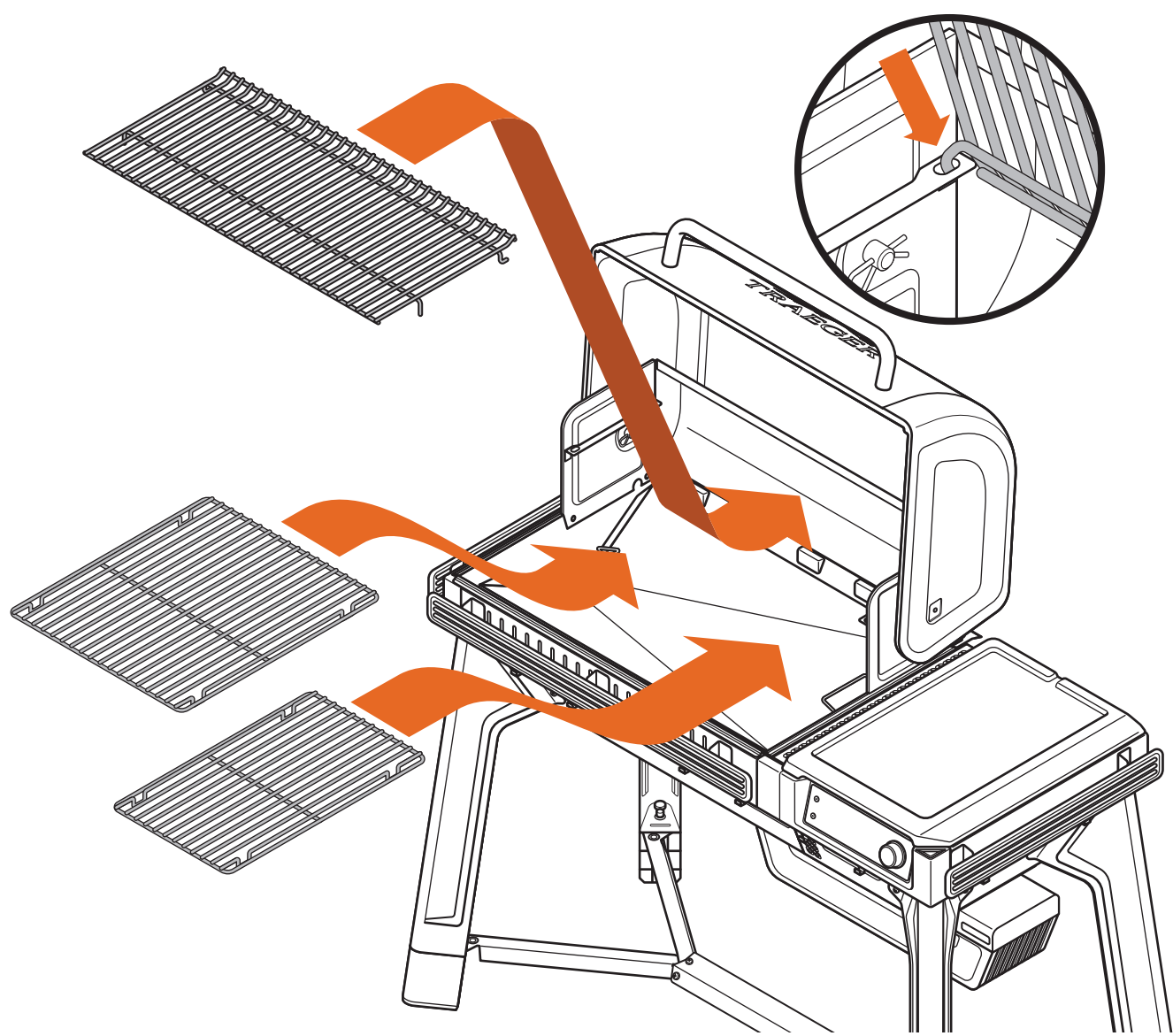
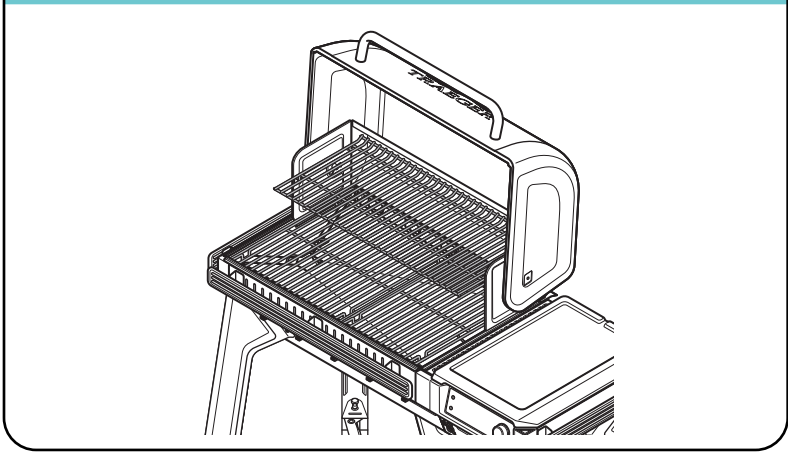



5 FETT-ASCHEBEHÄLTER EINBAUEN

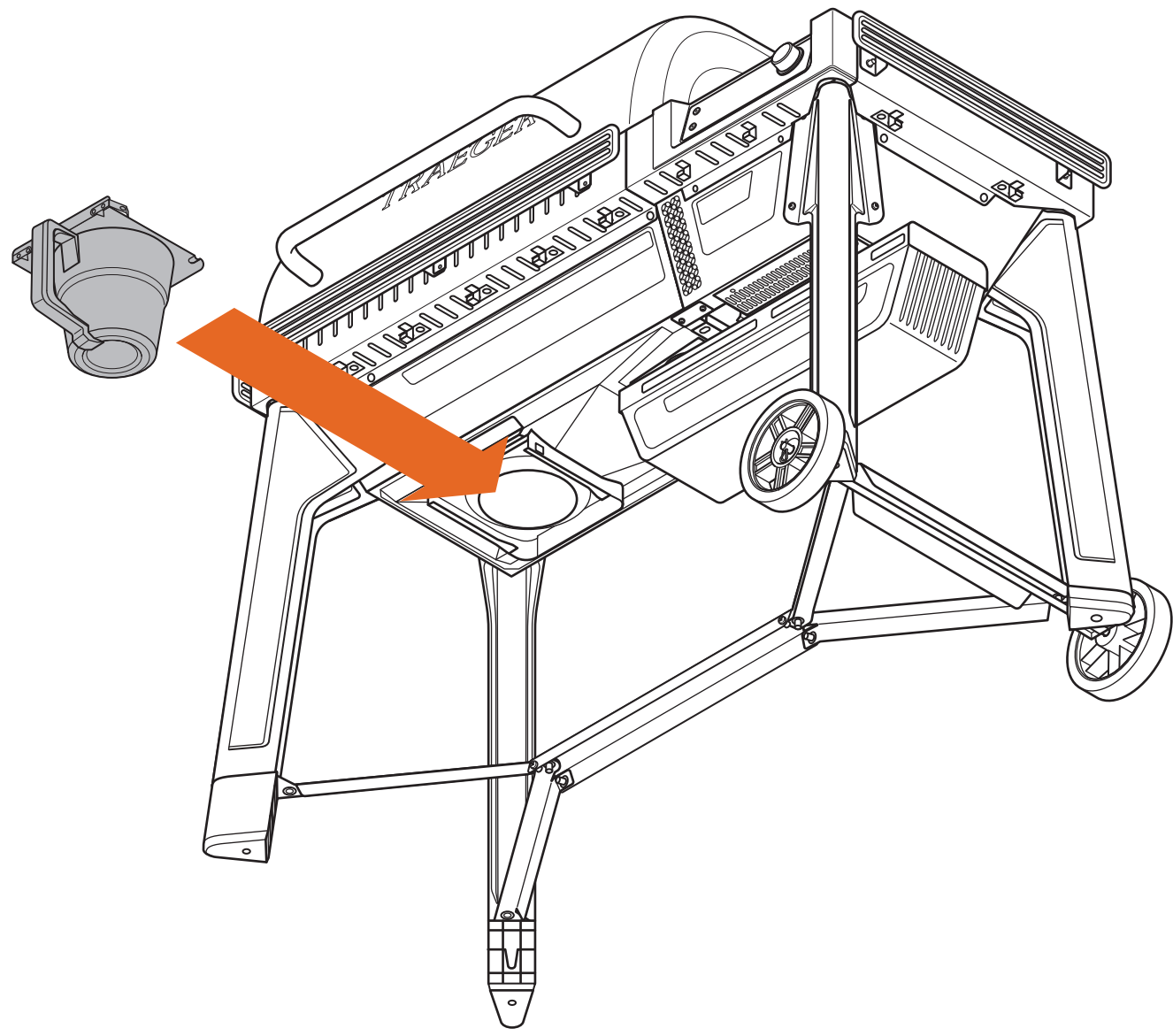
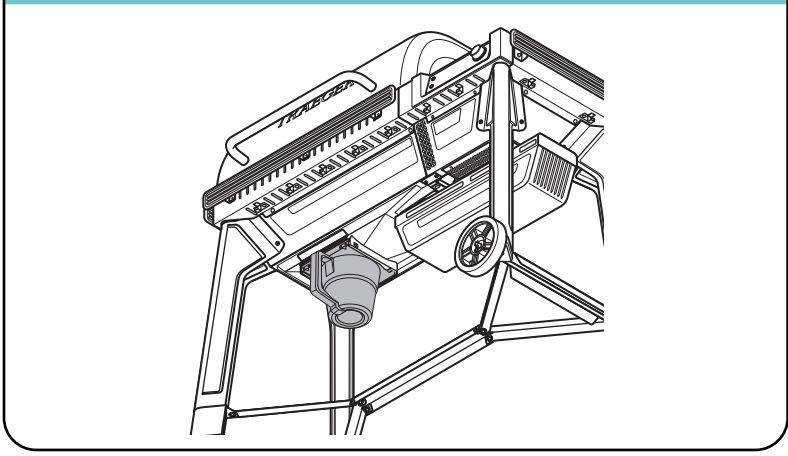



6 NETZKABEL EINSTECKEN

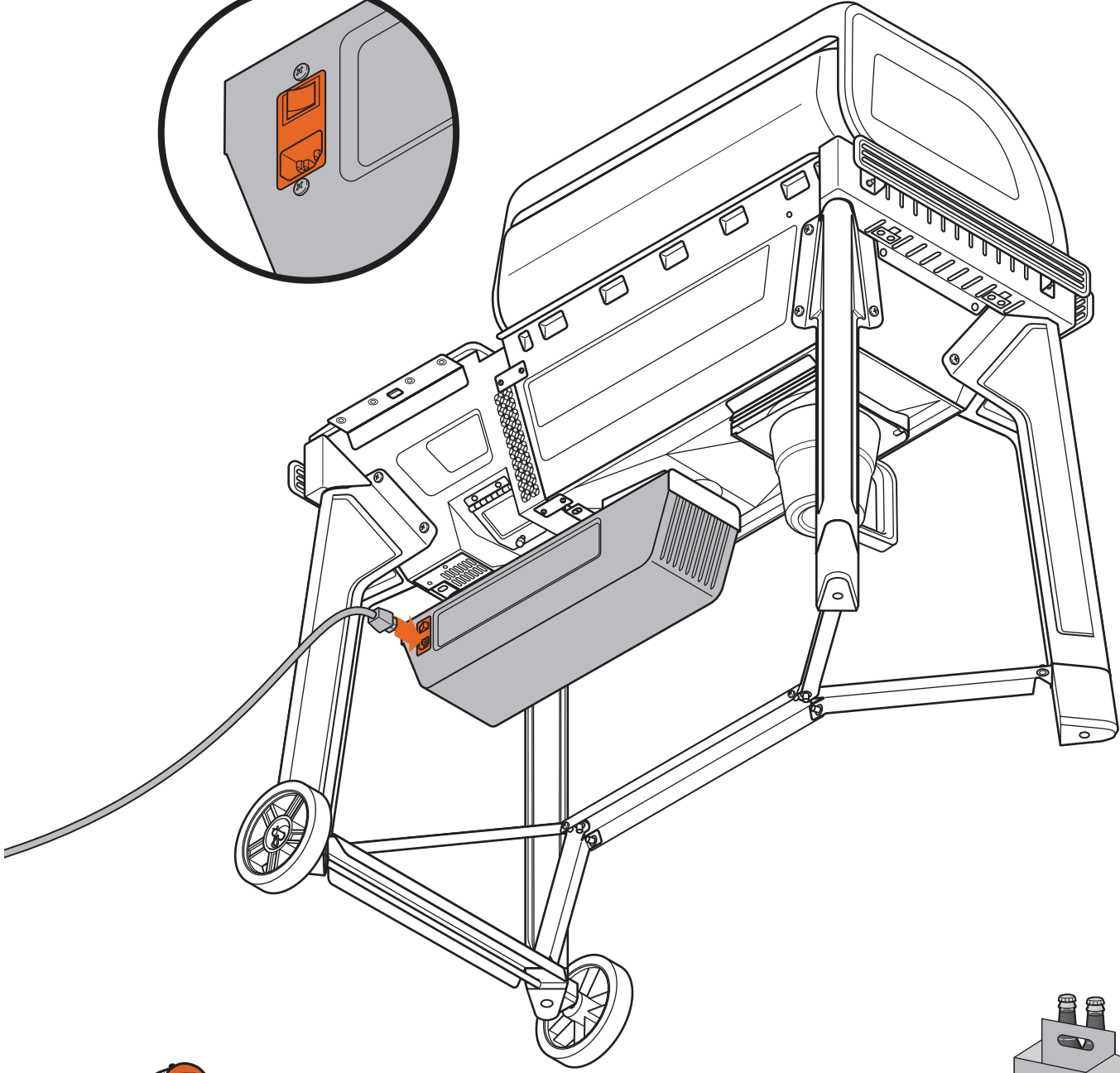
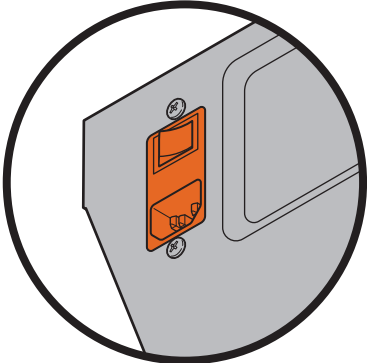
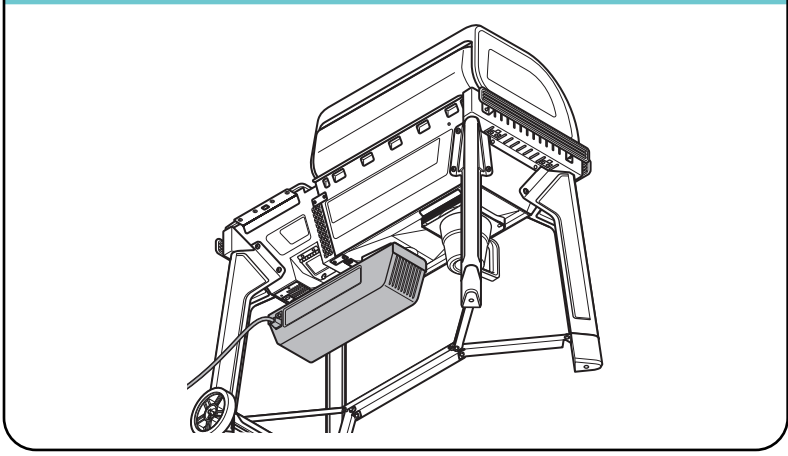

**GUTE ARBEIT!
KAPITEL 4 ABGESCHLOSSEN!**

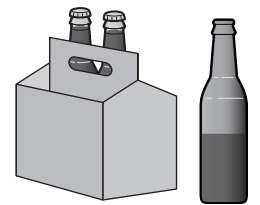



AUFBEWAHRUNG VON TEILEN UND ZUBEHÖR

Kabelgebundener Temperaturfühler und Netzkabel

AUFBEWAHRUNG:

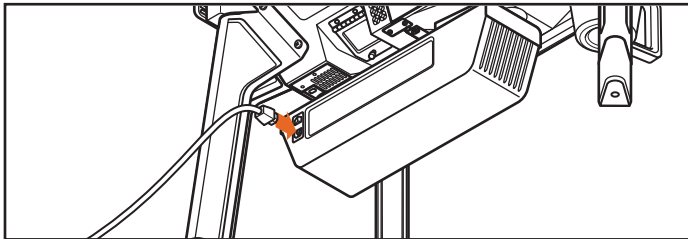
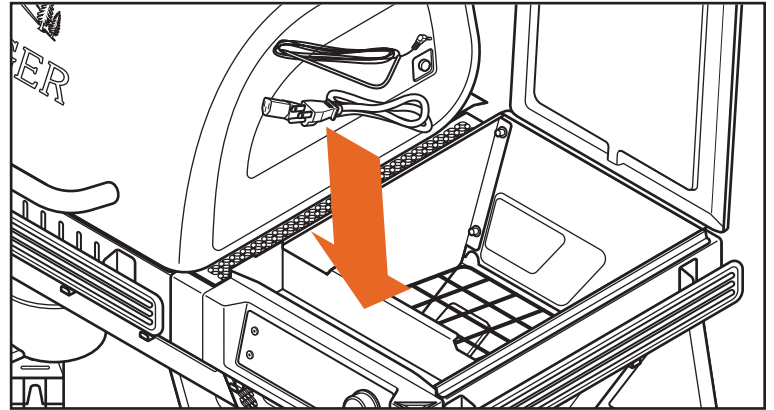
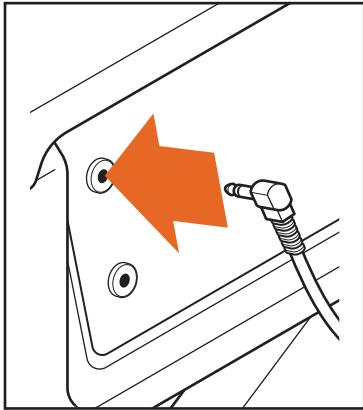

Grillroste, Tropfschale, Fettablaufrinne und Glutschutz

AUFBEWAHRUNG WÄHREND DER REINIGUNG:

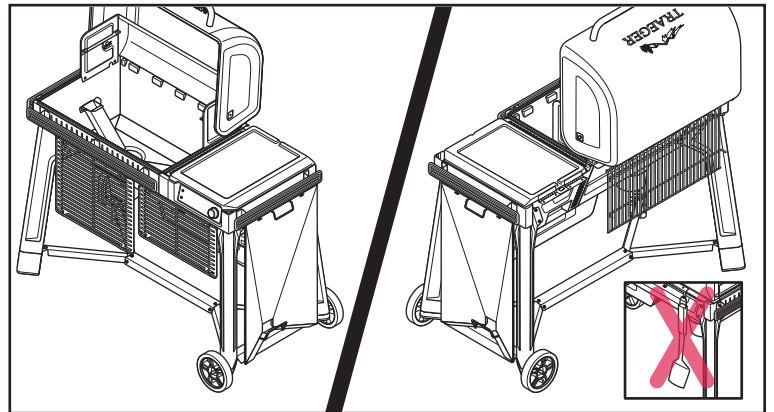
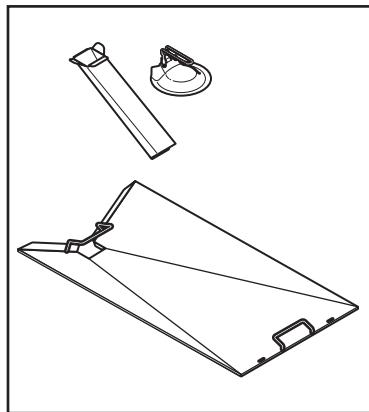
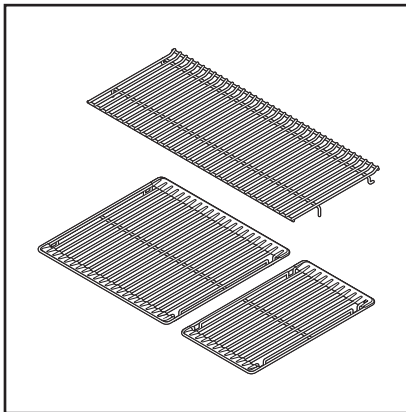

PROFI-TIPP: Hängen Sie keine Kochutensilien oder Stromkabel zur Aufbewahrung an die Rosthaken. Dadurch könnten die Utensilien oder das Netzkabel beschädigt werden.



VERBINDUNG MIT DEM GRILL HERSTELLEN

Unser Engagement für die Bereitstellung erstklassiger Produkte und Erlebnisse bedeutet, dass wir ständig daran arbeiten, die Leistung und Funktionen des Grills zu verbessern. Wir empfehlen Ihnen dringend, Ihren Traeger Woodridge Grill mit WiFIRE zu verbinden. Befolgen Sie dazu die nachstehende Anleitung. Wenn der Grill angeschlossen und eingeschaltet ist, werden Updates automatisch heruntergeladen, um zu gewährleisten, dass der Grill immer optimal funktioniert.

WICHTIG:

- Achten Sie darauf, dass auf Ihrem Smartphone oder Tablet das neueste Betriebssystem ausgeführt wird und dass Bluetooth eingeschaltet ist.
- Wenn Sie ein Android-Gerät verwenden, aktivieren Sie die Standortdienste.
- Der Grill muss eingeschaltet sein, um ihn mit dem Haus-WLAN zu verbinden. Achten Sie darauf, dass der Hauptschalter **EINGESCHALTET** ist (I) und leuchtet.
- Das Signal Ihres WLAN-Routers zu Hause muss 2,4 GHz haben (ein Dualband-Router sollte auch funktionieren). Das 2,4-GHz-Band ist derzeit der Branchenstandard für vernetzte Haushaltsgeräte. Es hat eine bessere Reichweite und durchdringt Wände/Decken/Hindernisse besser als 5 GHz, das der Grill nicht erkennen kann.

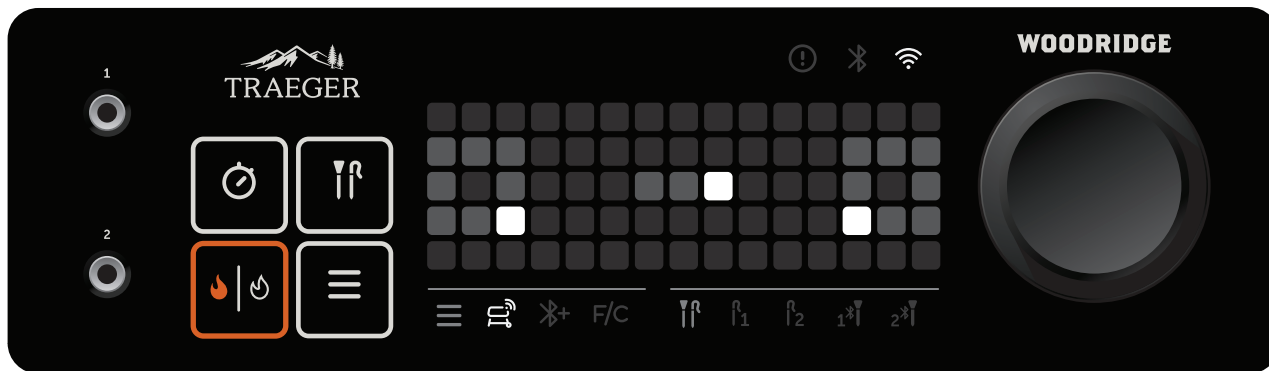

PROFI-TIPP: Unter dem Deckel der Pelletkammer finden Sie eine praktische Kurzanleitung für das Woodridge Bedienfeld!



1 Gehen Sie zum Apple App Store oder Android Google Play Store, um die neueste Version der Traeger-App herunterzuladen.

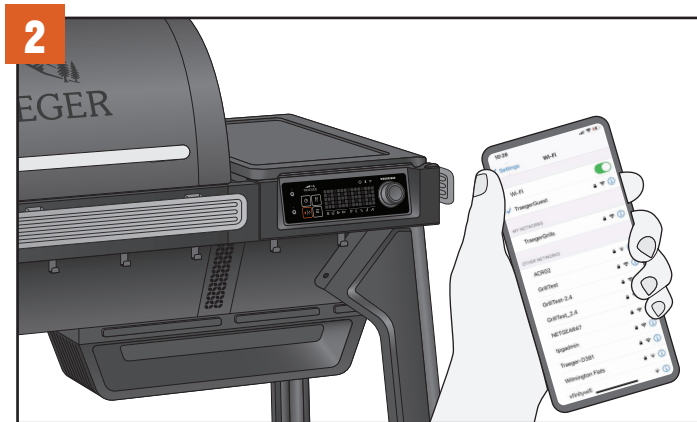

2 Achten Sie darauf, dass Ihr Smartphone oder Tablet mit dem WLAN verbunden ist, mit dem Sie den Grill verbinden möchten. Das Routersignal muss 2,4 GHz haben, da der Grill mit 5 GHz nicht kompatibel ist.

VERBINDUNG MIT DEM GRILL HERSTELLEN FORTSETZUNG

3

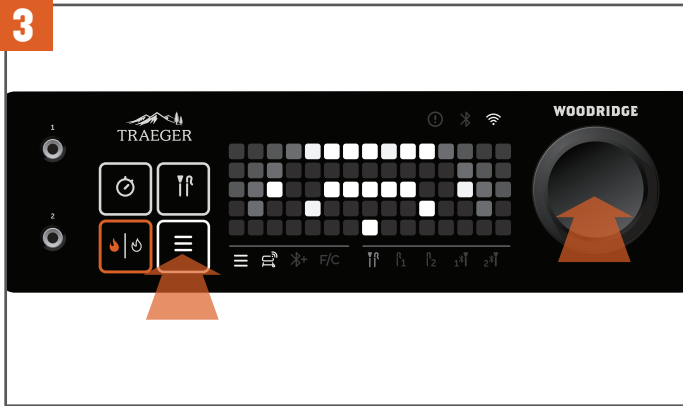

Tippen Sie nach dem Einschalten des Grills auf die Menütaste. Sie sehen, wie das WLAN-Symbol des Grills in der Menüleiste unter der Punktmatrix aufleuchtet und die Animation eines WLAN-Signals mit einem Fragezeichen angezeigt wird. Drücken Sie das Auswahlrad, um diese Option auszuwählen und den Verbindungsvorgang zu starten.

HINWEIS: Sie können durch die Menüoptionen navigieren, indem Sie nach dem Tippen auf die Menütaste das Auswahlrad drehen. Beim Drehen des Rads leuchten die Menüleistensymbole unter der Punktmatrixanzeige auf, um die Auswahl anzuzeigen.

4

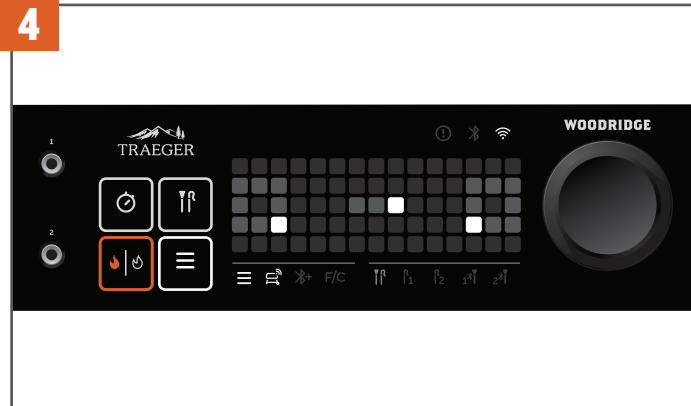

Nach der Auswahl von WiFIRE wird die obige Kopplungsanimation auf dem Bildschirm angezeigt. Dies zeigt an, dass der Grill ein Bluetooth-Signal sendet und zur Kopplung bereit ist. Öffnen Sie auf Ihrem Smart-Gerät die Traeger-App und melden Sie sich bei Ihrem Konto an. Tippen Sie auf dem Startbildschirm der Traeger-App auf das Grillsymbol unten in der Bildschirmmitte, um eine Verbindung herzustellen.

Befolgen Sie die Anweisungen in der Traeger-App, um (1) Ihr Telefon mit dem Grill zu koppeln (über eine temporäre Bluetooth-Verbindung), (2) den Grill mit Ihrem gewünschten 2,4-GHz-Heim-WLAN-Netzwerk zu verbinden und (3) den Einrichtungsvorgang des Grills abzuschließen.

5

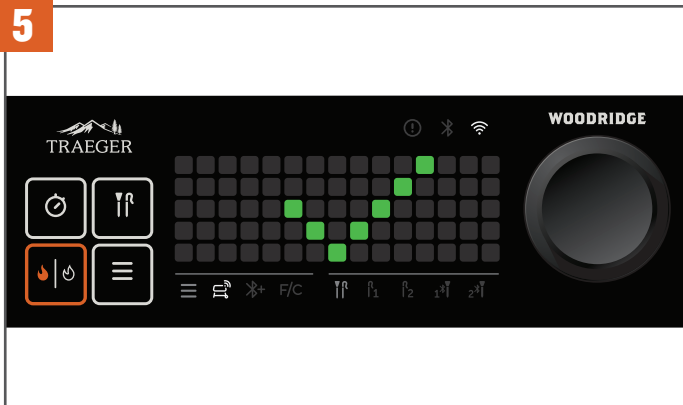

Auf dem Bedienfeld wird ein grünes Häkchen angezeigt, das angibt, dass Sie erfolgreich eine Verbindung zu WiFIRE hergestellt haben. Das WLAN-Symbol oben rechts über der Matrixanzeige leuchtet durchgehend, wenn der Grill eine Verbindung hat.

6

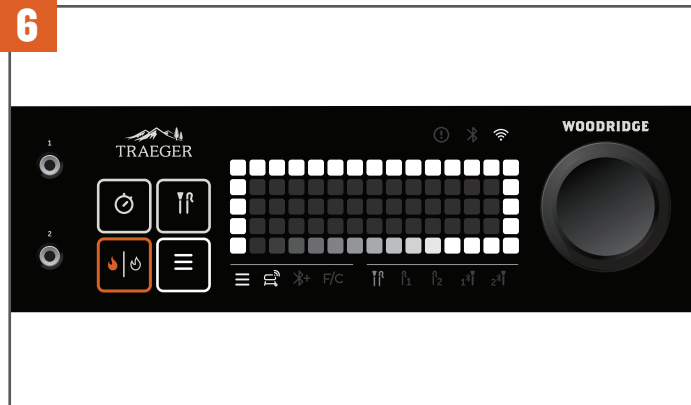

Nachdem eine Verbindung zu WiFIRE besteht, sehen Sie möglicherweise diese Animation auf Ihrem Bildschirm. Schalten Sie den Grill erst aus, wenn ein grünes Häkchen angezeigt wird. Dies bedeutet, dass der Grill ein Update herunterlädt und anwendet. Genau wie bei Ihrem Smartphone sorgen diese Updates dafür, dass Ihr Grill reibungslos, sicher und optimal funktioniert. Nachdem das Update abgeschlossen ist, sehen Sie ein grünes Häkchen und der Grill kehrt in den Ruhemodus zurück – und es kann losgehen!

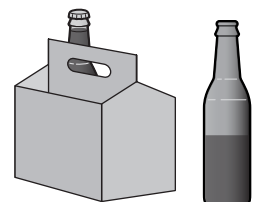

EINBRENNEN DES GRILLS



PROFI-TIPP: Das Einbrennen muss abgeschlossen sein, bevor Sie Lebensmittel auf dem Grill zubereiten. Für weitere Informationen scannen Sie hier, um den Einbrennleitfaden anzuzeigen.

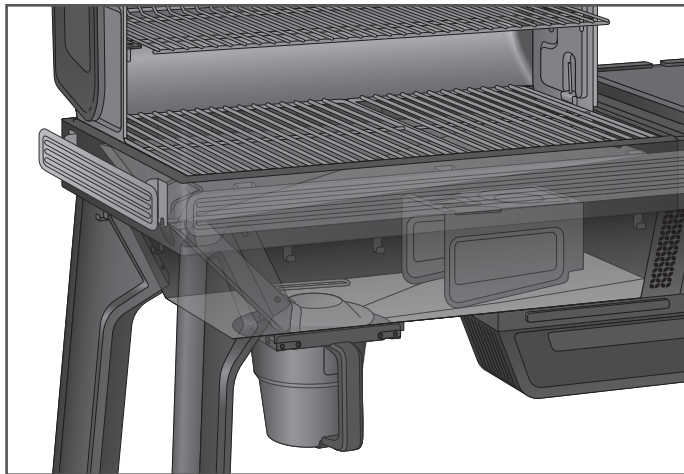

WICHTIG:

- Achten Sie darauf, dass alle Komponenten ordnungsgemäß im Grill installiert sind und dass vor dem Einbrennen sämtliche Verpackungs-/Versandmaterialien entfernt wurden.
- Wischen Sie die schützende Fettschicht vor dem Einbrennen nicht von den Komponenten ab. Diese Beschichtung bietet eine haltbarere Einbrennschutzschicht.

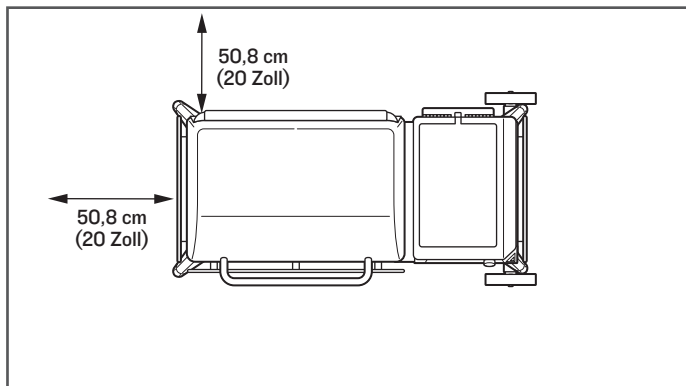

⚠️ WARNUNG Feuergefahr

- Halten Sie beim Betrieb Ihres Traeger-Grills einen **MINIMALEN** Abstand von 50,8 cm (20 Zoll) zwischen dem Grill und allen brennbaren Gegenständen in der Nähe ein, einschließlich Holzgeländern, Hausverkleidungen, Fensterrahmen, Möbeln, Bäumen und Abfallbehältern usw.

Bevor Sie auf Ihrem Grill kochen können, muss er eingebrannt werden. Dabei handelt es sich um einen berührungslosen Vorgang, bei dem der leere Grill auf eine sehr hohe Temperatur erhitzt wird. Dieser Einbrennzyklus stellt sicher, dass der Grill von allen Fabrikrückständen gereinigt, vorbereitet und für optimale Leistung bereit ist.

⚠️ GEFAHR Gefahr durch Kohlenmonoxid

Bei der Verbrennung von Holzpellets entsteht Kohlenmonoxid, das zu Krankheit, schweren Verletzungen und/oder zum Tod führen kann. Um zu verhindern, dass dieses farblose, geruchlose Gas Sie, Ihre Familie, Ihre Haustiere oder andere gefährden kann, befolgen Sie diese Anleitung:

- Betreiben Sie Ihren Traeger-Grill nur im Freien in einem gut belüfteten Bereich. Dieser Grill ist **AUSSCHLIESSLICH** für die **BENUTZUNG IM FREIEN** bestimmt.
- Benutzen Sie Ihren Traeger-Grill **niemals** in einem geschlossenen Bereich oder in einem Bereich ohne ausreichende Belüftung.
- Erkennen Sie die Symptome einer Kohlenmonoxid-Vergiftung: Kopfschmerzen, Schwindel, Schwäche, Übelkeit, Erbrechen, Müdigkeit und Verwirrung. Kohlenmonoxid verringert die Fähigkeit des Blutes, Sauerstoff zu transportieren. Ein zu niedriger Sauerstoffgehalt im Blut kann zu Bewusstlosigkeit und Tod führen.
- Sollten Sie oder andere Personen erkältungs- oder grippeähnliche Symptome entwickeln, während Sie grillen oder sich in der Umgebung eines Grills aufhalten, suchen Sie einen Arzt auf. Kohlenmonoxid-Vergiftungen werden oft zu spät bemerkt, da sie leicht mit Erkältungs- oder Grippeerkrankungen verwechselt werden.
- Alkohol- oder Drogenkonsum verstärken die Effekte einer Kohlenmonoxid-Vergiftung.
- Kohlenmonoxid gefährdet insbesondere: Mutter und Kind während der Schwangerschaft, Kleinkinder, ältere Menschen, Raucher und Menschen mit Herz-Kreislauf-Erkrankungen wie beispielsweise Anämie oder Herzerkrankungen.

⚠️ WARNUNG Feuergefahr

- Verwenden Sie **niemals** Benzin, Petroleum, Kerosin, Feuerzeugbenzin oder andere brennbare Materialien, um ein Feuer zu entzünden oder „aufzufrischen“.
- Verwenden oder lagern Sie **niemals** brennbare Flüssigkeiten oder andere brennbare Materialien in der Nähe des Grills.

⚠️ WARNUNG Verbrennungsgefahr

Asche sollte vor der Handhabung immer vollständig abgekühlt sein. Aschereste sollten in einem Metallbehälter mit gut schließendem Deckel entsorgt werden. Der geschlossene Aschebehälter muss bis zur endgültigen Entsorgung auf nicht brennbarem Untergrund und in sicherem Abstand zu brennbaren Materialien aufbewahrt werden. Die Asche sollte bis zu ihrer Entsorgung im geschlossenen Behälter aufbewahrt werden.

⚠️ WARNUNG Verwenden Sie keine Heizpellets

Verwenden Sie niemals Heizpellets im Grill, da diese möglicherweise gefährliche Verunreinigungen und Zusätze enthalten und den Grill beschädigen können.

EINBRENNEN DES GRILLS FORTSETZUNG

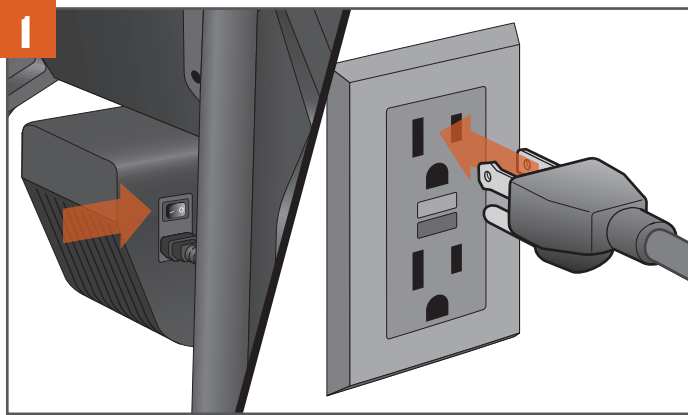

Schließen Sie das Netzkabel bei ausgeschaltetem (0) Hauptschalter an den Grill an. Stecken Sie dann das Netzkabel in eine ordnungsgemäß geerdete Steckdose, die durch einen Fehlerstrom-Schutzschalter (GFCI) geschützt ist.

HINWEIS: Der Stecker kann je nach Land oder Region variieren.



WARNUNG! GEFAHR DURCH ELEKTRISCHEN SCHLAG
GEFÄHRLICHE SPANNUNGEN KÖNNEN ZU
STROMSCHLAG, VERBRENNUNGEN ODER ZUM TOD
FÜHREN.

- DIE STROMKREISE UND STECKDOSEN, DIE FÜR DEN BETRIEB DIESES TRAEGER GRILLS VERWENDET WERDEN, MÜSSEN MIT EINEM FEHLERSTROM-SCHUTZSCHALTER (GFCI) AUSGESTATTET SEIN.

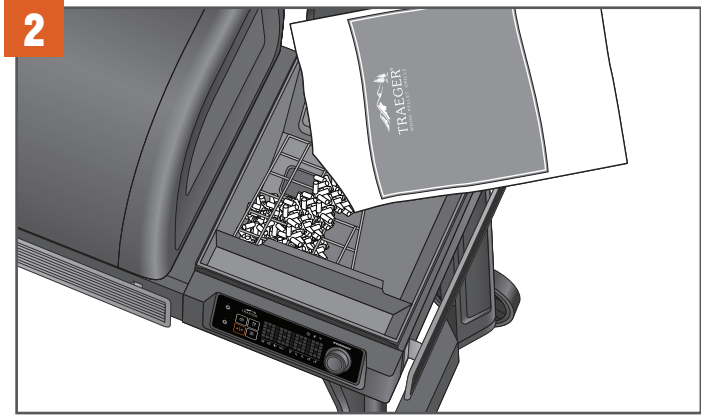

Um Pellets hinzuzufügen, öffnen Sie den Deckel der Pelletkammer und prüfen, ob sich Fremdkörper in der Förderschnecke befinden. Füllen Sie die Pelletkammer mindestens bis zum Sicherheitsrost mit Pellets und schließen Sie den Deckel.

VERWENDEN SIE AUSSCHLIESSLICH HARTHOLZ-PELLETES DER MARKE TRAEGER. Dieses Produkt wurde ausschließlich unter Verwendung von Traeger-Pellets entwickelt und optimiert. Traeger-Pellets werden nach strengen Qualitäts- und Leistungsstandards hergestellt. Die Verwendung von Pellets, die nicht von Traeger hergestellt wurden, kann zu abweichender Leistung, geschmacklichen Mängeln und Temperaturschwankungen führen.

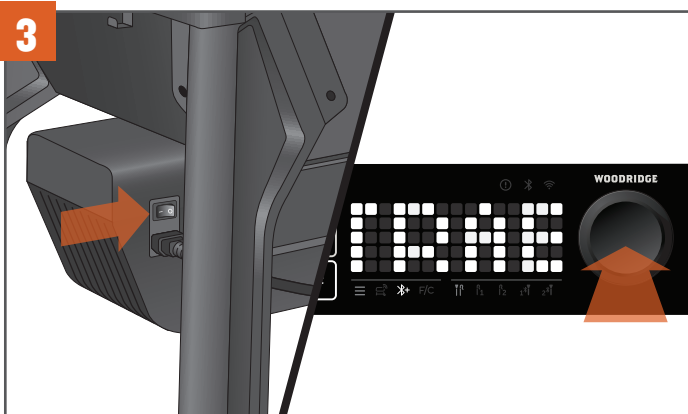

Schalten Sie den Hauptschalter an der Rückseite des Förderschneckengehäuses ein (I). Drücken Sie auf das Auswahrad, um den Ruhemodus zu verlassen. „TRAEGER“ läuft über den Bildschirm und zeigt an, dass der Grill eingeschaltet ist.



Drehen Sie das Auswahrad, um die Grilltemperatur auf 350 °F (177 °C) einzustellen, und drücken Sie dann auf das Auswahrad. Drücken Sie auf die Zünd-/Abschalttaste.



PROFI-TIPP: Dieser Einbrennvorgang ist wichtig, um eine einwandfreie Grillfunktion zu gewährleisten. Stellen Sie sicher, dass alle internen Komponenten vor diesem Einbrennzyklus ordnungsgemäß eingebaut wurden und dass sich während dieses Vorgangs keine Lebensmittel auf den Grillrosten befinden.



Die Grilltemperatur wird angezeigt, während sie auf die eingestellte Temperatur ansteigt.

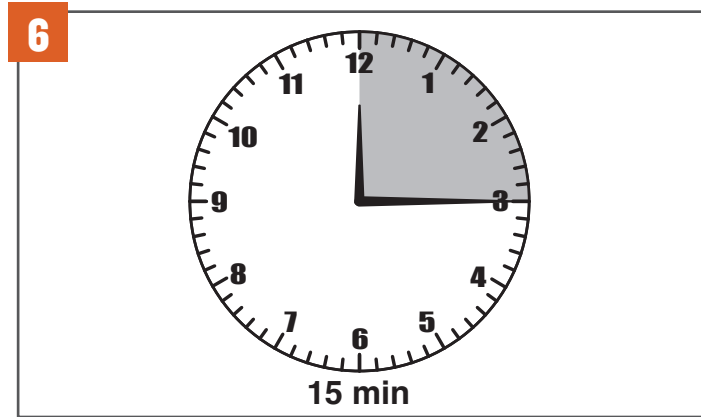

Nachdem der Grill 350 °F (177 °C) erreicht hat, lassen Sie ihn 15 Minuten lang laufen. Während der Grill einbrennt, können sich dunkler oder übermäßiger Rauch und Asche bilden. Dies ist normal und wird bei späteren Einschaltvorgängen weniger auftreten.

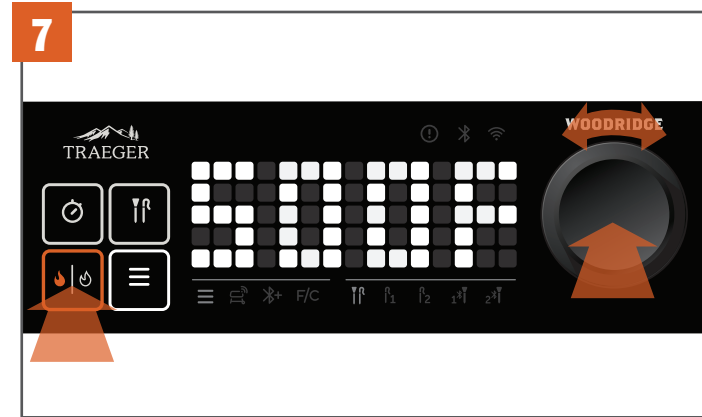

Erhöhen Sie die Temperatur nach 15 Minuten bei 350 °F (177 °C) auf 500 °F (260 °C).

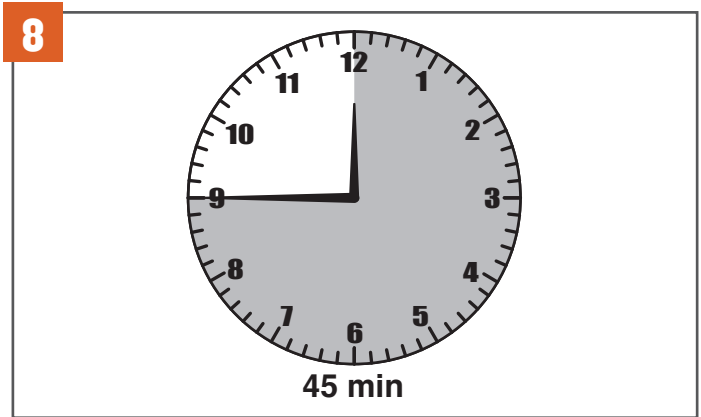

Sobald der Grill eine Temperatur von 500 °F (260 °C) erreicht hat, lassen Sie ihn weitere 45 Minuten laufen, um zu gewährleisten, dass der Einbrennvorgang ordnungsgemäß abgeschlossen wird.

HINWEIS: Es kann bis zu einer Stunde dauern, bis die erste Einbrenntemperatur erreicht ist.

EINBRENNEN DES GRILLS FORTSETZUNG



Schalten Sie den Grill nach 45 Minuten bei 500 °F (260 °C) aus und lassen Sie den Abschaltzyklus zu Ende kommen. Um den Grill auszuschalten, halten Sie die Zünd-/Abschalttaste oder das Auswahlrad drei Sekunden lang gedrückt, bis auf dem Display die Ausschaltanimation angezeigt wird.

HINWEIS: Leiten Sie nach jedem Garvorgang immer einen Abschaltzyklus ein.



Während der Grill abgeschaltet wird, läuft ein Countdown-Timer. Sie hören, dass der Lüfter weiterläuft.

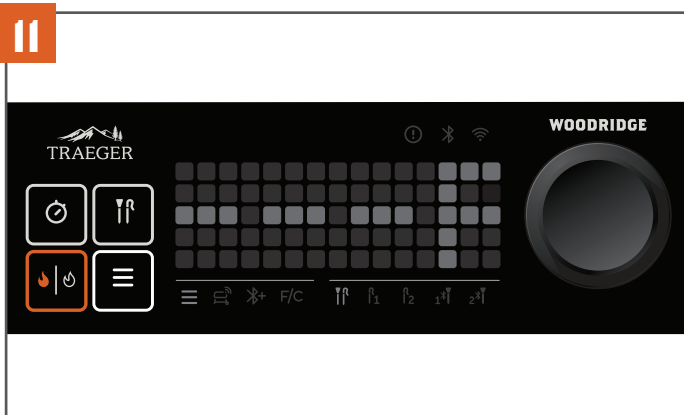

Nachdem dieser Countdown abgelaufen ist, ist der Abschaltzyklus abgeschlossen.

HINWEIS: Es ist normal, dass sich nach dem Einbrennen Asche auf der Tropfschale und/oder den Grillrosten bildet. Wischen Sie vor dem ersten Grillen einfach die Asche vom Grillrost ab.

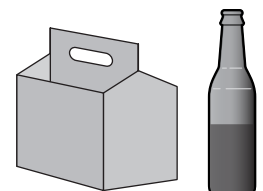



NOTIZEN



